



Lieu Dit Bacqué, rue André Thevet  
47400 FAUILLET - FRANCE  
Tél: 33 (0)5 53 79 83 20  
Fax: 33 (0)5 53 79 96 90  
Email: contact@atnplatforms.com

# Operator and Safety Manual



## **MYGALE 2B**

Translation from the original manual



OPERATOR AND SAFETY MANUAL



DISTRIBUTOR'S STAMP



## FOREWORD

This manual has been compiled to assist to properly use and maintain your Mygale 23 self-propelled work platform.

Take the time to carefully read and familiarise yourself with its content. Once you have read and understood all sections, keep this manual in the manual storage box provided to this effect in the platform.

The information in this manual does not, in any case, replace community, state, local regulations or safety instructions or insurance policy requirements.

Due to constant improvements made to its products, **ATN** reserves the right to alter their specifications and equipment without prior notice.

## WARNING SYMBOLS AND SAFETY TERMS



These symbols warn the user of possible risks of injury and invite them to consult the operator and safety manual. The safety instructions which follow these symbols must be respected to avoid any risk of serious or fatal injury.



**DANGER**



**CAUTION**



INDICATES A DANGEROUS SITUATION WHICH MAY LEAD TO SERIOUS OR FATAL INJURIES IF THE SAFETY INSTRUCTIONS ARE NOT RESPECTED.

INDICATES A PROCEDURE OR OPERATION TO BE RESPECTED TO THE LETTER TO AVOID ANY RISK OF DAMAGES TO THE MACHINE.

### - NOTE-

These are generally remarks relating to a procedure or important condition for using the machine.



**OPERATOR AND SAFETY MANUAL**



<p>47400 FAUILLET (France) Tel: +33 (0)3 53 78 80 80 www.atnplatforms.com contact@atnplatforms.com</p>		<p>TYPE / MODEL MYGALE 23</p> <p>Poids à vide / GVW <b>3450 Kg</b></p> <p> 250 Bars max 3190 PSI max</p>
<p>12,5 m/s max 45 km/h max</p> <p>400 N max 40 kg max</p> <p>23 m. max</p>	<p> =  +  = <b>230 Kg</b> 160 + 70 max</p>	
<p> 32% max</p> <p> 15% max</p> <p> LEVEL ±0.2° max</p>	1AU01218-01	



**DANGER**

DO NOT USE THIS MACHINE IF YOU HAVE NOT BEEN PROPERLY TRAINED TO ITS SAFE OPERATION. TRAINING INCLUDES KNOWLEDGE OF YOUR EMPLOYER'S WORK REGULATIONS, THE INSTRUCTIONS IN THIS MANUAL AND THE REGULATION IN FORCE FOR THIS TYPE OF MACHINE.

AN UNTRAINED OPERATOR PUTS HIMSELF AND OTHERS AT RISK OF DEATH OR SERIOUS INJURIES.

**DANGER**

NEVER EXCEED THE PLATFORM'S RATED CAPACITY. THE LOAD MUST BE EVENLY DISTRIBUTED ACROSS THE WORK PLATFORM FLOOR. DO NOT RAISE THE PLATFORM OR MOVE WITH THE PLATFORM RAISED ON INCLINES, HILLY OR SOFT SURFACES. ALL 4 OUTRIGGERS MUST REMAIN IN PERMANENT CONTACT WITH THE GROUND WHEN ELEVATED.



**OPERATOR AND SAFETY MANUAL**



**GUARANTEE**

FOR ANY NEW EQUIPMENT, THERE IS NO OTHER GUARANTEE, EXPLICIT OR IMPLICIT, THAT THE VENDOR GUARANTEE COVERS MATERIAL OR MANUFACTURING FLAWS WRITTEN IN THE FOLLOWING TERMS:

**GUARANTEE ON NEW EQUIPMENT**

"The Manufacturer guarantees each new product against any material or manufacturing flaw, his obligation and liability being limited under this guarantee to repairing or replacing, free of charge in his factory, any part acknowledged as being faulty in normal use and maintenance, and the reasonable cost of repair and/or replacement of the said parts within twenty four (24) months from the initial date of sale (5 years for the structure), leasing with purchase option, provided equipment start-up by the Distributor was registered with the Manufacturer. In case of lack of registration with the Manufacturer, the date used as initial date of sale, leasing with purchase option is the date on which the equipment was shipped from the plant. This guarantee replaces any other explicit or implicit guarantee and the Manufacturer's liability within this guarantee excludes shipping or other expenses, or any other liability for direct, indirect or consecutive damage, as well as any delay due to any flaw. This fact does not extend the period of guarantee of the machine, nor that of the parts replaced. The guarantee is cancelled in case of use beyond capacities or in conditions not planned by the Manufacturer, or when using parts not approved by the said Manufacturer.

THIS GUARANTEE REPLACES EXPRESSLY ANY OTHER EXPLICIT OR IMPLICIT GUARANTEE, INCLUDING ANY IMPLICIT GUARANTEE OF MERCHANTABILITY OR PROPER ADAPTATION TO A GIVEN APPLICATION AND ANY OTHER OBLIGATION OR LIABILITY OF THE VENDOR.

**FOR THE ATTENTION OF THE CUSTOMER / USER**

If this platform is involved in an accident, please contact your distributor immediately and provide them with all the details of the accident. If you do not know who your distributor is, or cannot inform them, please contact:



Tel: 33 (0)5 53 79 83 20

Fax: 33 (05) 53 88 01 07

Adresse: Lieu-Dit Bacqué, rue André Thevet, 47400 Fauillet, France



## OPERATOR AND SAFETY MANUAL



### A.T.N. - S.A.

Head office: Lieu Dit Bacqué – Rue André Thevet, 47400 Fauillet, France  
Administrative and accounting: Lieu Dit Bacqué – Rue André Thevet, 47400 Fauillet, France  
RCS Agen 429 807 597 – Code APE/ 2822Z – SIRET 429 807 597 00068 - Capital 57900 €

---

## ***EC CONFORMITY DECLARATION***

---

The manufacturer: A.T.N. declares that the machine designated below:

Denomination ..... MEWP (Mobile Elevating Work Platform)  
Function ..... Elevation of persons for work at heights  
Type ..... Diesel Elevating Platform with articulated arm (Groupe B – Type 1)  
Model and commercial designation ..... **MYGALE 23**  
Serial Number ..... **M23xxxx**

meets all of the relevant provisions in the appendix at the end of the 1st chapter in book III of the fourth section of the employment code (Machine Directive 2006/42/CE of 17th May 2006), also meets other relevant provisions such as EMC directive 2004/108/CE of 15th December 2004 and the noise emission directive 2000/14/CE of 8th May 2000.

This machine also conforms to standard NF EN280.

Acoustic Power level : 104dB

The EC type certificate has been awarded by:

APAVE

13 à 17 rue Salneuve

75854 PARIS CEDEX 17

Under the reference:

**0060 / 5253 / 760 / 05/16 / 0009**



## TABLE OF CONTENTS

<b>Section 1. GENERAL DESCRIPTION .....</b>	<b>8</b>
1.1. DESCRIPTION .....	8
1.2. CHARACTERISTICS - DIMENSIONS .....	9
<b>Section 2. SAFETY INSTRUCTIONS.....</b>	<b>13</b>
2.1. GENERAL .....	13
2.2. TIPPING HAZARDS .....	14
2.3. CRUSHING AND COLLISION HAZARDS .....	15
2.4. ELECTROCUTION HAZARDS .....	16
2.5. FALLING HAZARDS .....	17
2.6. OTHER RISKS .....	17
2.7. OPERATION LIMITS .....	17
2.8. TOWING, LIFTING, TRANSPORT .....	18
2.9. MAINTENANCE.....	18
<b>Section 3. PREPARATION AND INSPECTION .....</b>	<b>19</b>
3.1. INSPECTION BEFORE START UP .....	19
3.2. INSPECTION TOUR .....	19
3.3. OPERATING CHECKS.....	22
<b>Section 4. OPERATION .....</b>	<b>23</b>
4.1. CONTROLS AND INDICATORS .....	24
4.2. HEAT ENGINE OPERATION .....	33
4.3. ELECTRIC MOTOR OPERATION .....	35
4.4. DRIVE - STEERING .....	36
4.5. ELEVATING STRUCTURE .....	38
4.6. PARKING – STORAGE .....	42
4.7. HANDLING – STOWAGE FOR TRANSPORT .....	43
4.8. OUTRIGGERS .....	45
<b>Section 5: SAFETY DEVICES .....</b>	<b>48</b>
5.1 TILT SENSOR .....	49
5.2 LOAD CONTROL .....	49
5.3 SYSTEM FAULT .....	50
5.4 MOVEMENT ALARM.....	50
<b>Section 6 : EMERGENCY PROCEDURES.....</b>	<b>51</b>
6.1 EMERGENCY CONTROLS .....	51
6.2 AFTER AN INCIDENT .....	51
<b>Section 7: MAINTENANCE FOR THE OPERATOR.....</b>	<b>52</b>
7.1 HEAT ENGINE.....	52
7.2 LUBRIFICATION .....	53
7.3. TRACKS .....	55
7.4. MOTOR REDUCERS .....	56
7.5. BATTERY.....	57
<b>Section 8. SCHEMAS.....</b>	<b>58</b>
8.1. ELECTRICAL SCHEMATIC.....	59
8.2. HYDRAULIC SCHEMATIC.....	60



OPERATOR AND SAFETY MANUAL



Section 1. GENERAL DESCRIPTION

1.1. DESCRIPTION

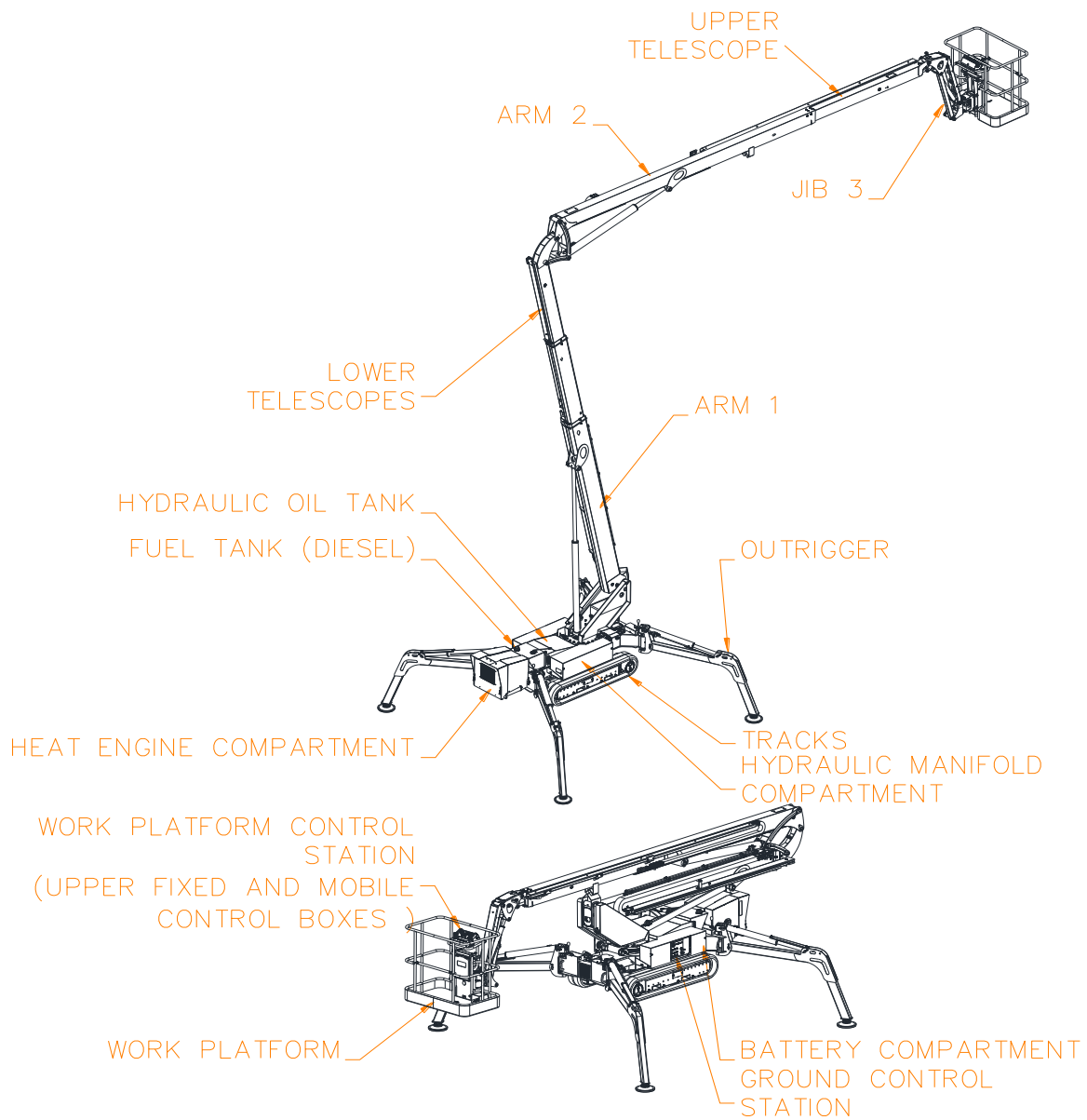





## OPERATOR AND SAFETY MANUAL



### 1.2. CHARACTERISTICS - DIMENSIONS

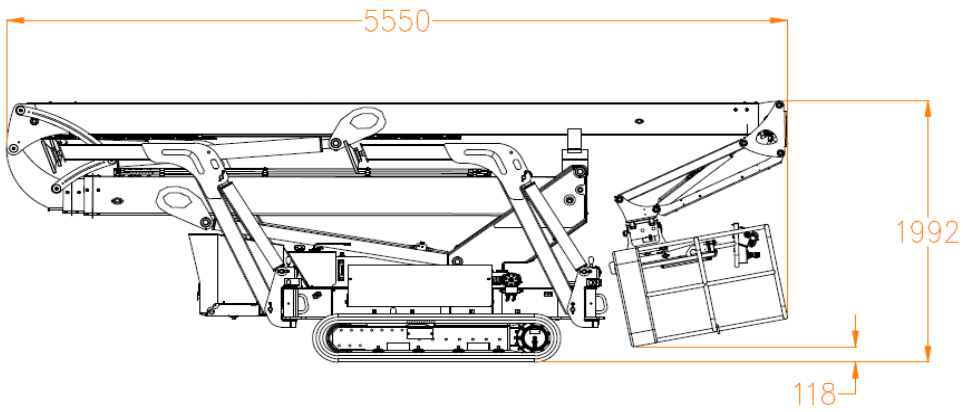
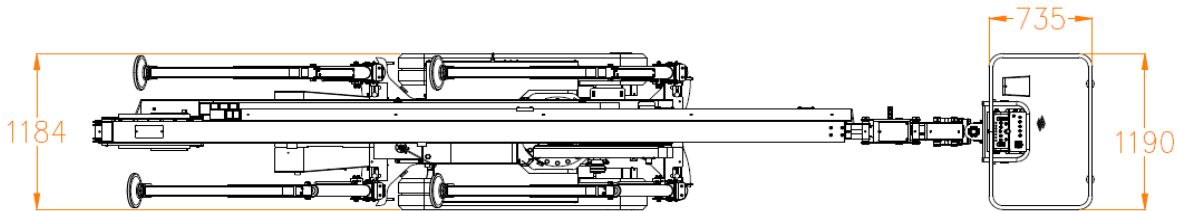
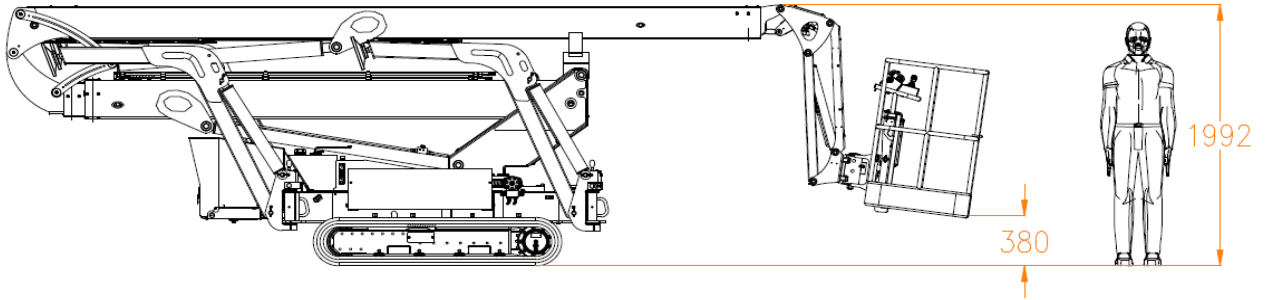



OPERATOR AND SAFETY MANUAL

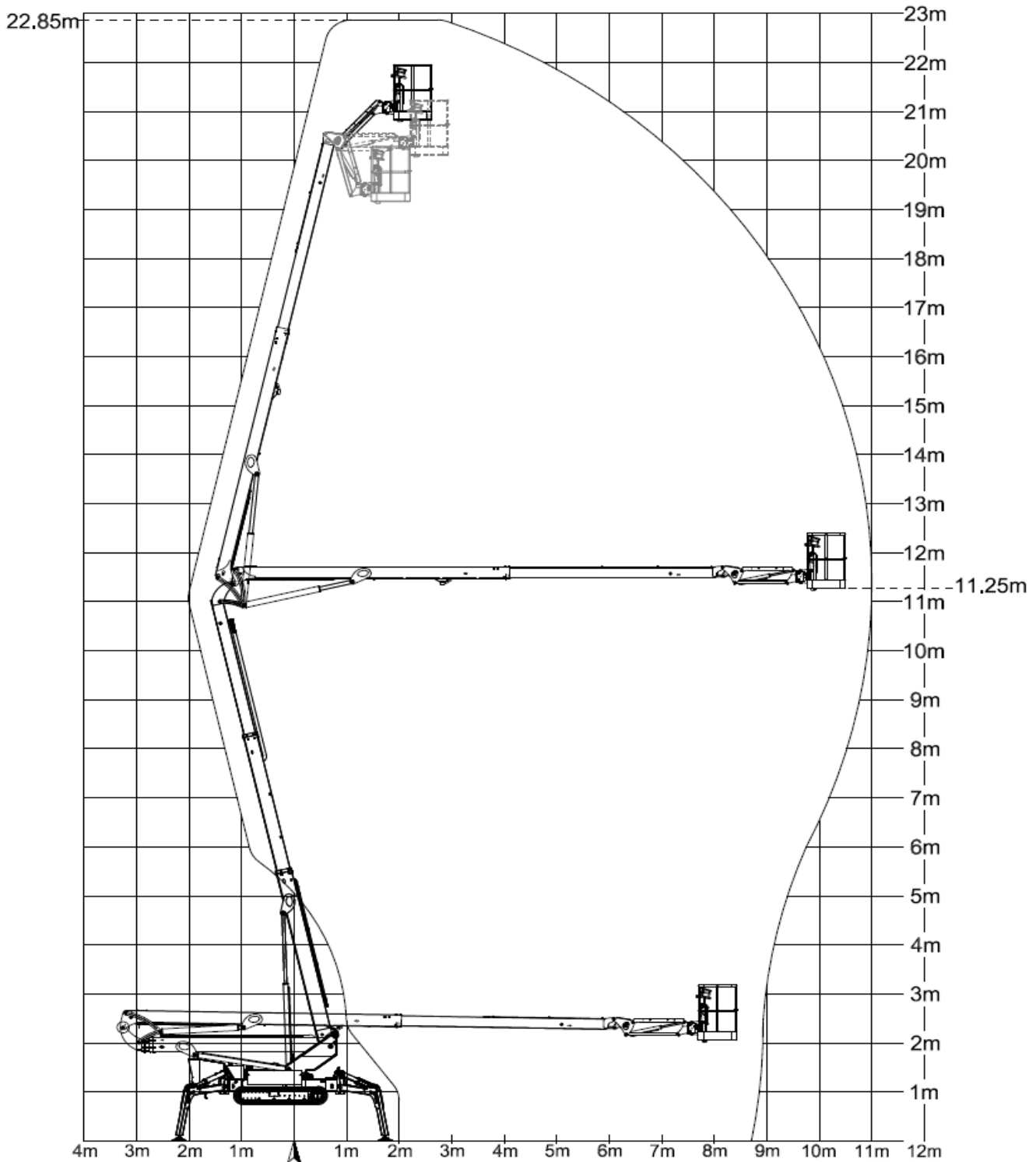



**OPERATOR AND SAFETY MANUAL**



CHARACTERISTICS		Mygale 23
Max. working height		22.85 m
Max. floor height		20.85 m
Min. floor height		0.40 m
Max. outreach (at centerline)		11.00 m
Max working outreach (at centerline)		11.25 m
Structure orientation		352° (Non continu- 2x176°)
Work platform rotation		2x 90°
Work platform dimensions		0.73 x 1.19 m
Max number of people on the platform		2
Platform rated load		230 kg
Max. wind speed		12.5 m/s (45 km/h)
Max manual force		400 Newton
Max. longitudinal slope permitted		32%
Max. side slope permitted		15%
Overall length (Transport position)		6.68 m
Overall length (Storage position)		5.55 m
Overall width		1.18 m
Overall height		1.99 m
Wheelbase		1.42 m
Ground clearance (middle of chassis)		0.17 m
Travel speed	Fast	1.5 km/h
	Slow	0.5 km/h
Empty weight		3 450kg
Floor load on one outrigger (*)	Force	8880 N
	Contact pressure	1.7 kg/cm <sup>2</sup>
(*) : The floor load values indicated may vary depending on the configuration/position of the machine. an adequate safety margin with respect to these values should always be kept..		
The weighted acoustic pressure level A on the platform's control station is 78 dB(A). The weighted acoustic power level emitted by the machine (LWA) is 104 dB (test method according to European directive 2000/14/CE relating to noise emissions in the environment of equipment intended to be used outside buildings – Appendix III, Section B, Points 0 and 1).		
The total value of the vibrations to which the hand-arm system is exposed does not exceed 2.5m/s <sup>2</sup> . The average maximum quadratic value weighted by the acceleration frequency to which the whole body is exposed does not exceed 0.5m/s <sup>2</sup> .		
Due to constant improvements made to its products, <b>ATN</b> reserves the right to alter their specifications and equipment without notice .		



**OPERATOR AND SAFETY MANUAL**



MOVEMENT DURATIONS			Mygale 23	
			Heat engine	Electrical motor
Arm 1 + lower telescope	Up	Idle	135 to 165s	400 to 500s
		High regime	85 to 105s	255 to 315s
	Down	Idle	135 to 165s	400 to 500s
		High regime	75 to 95s	225 to 285s
Arm 2	Up	Idle	75 to 95s	225 to 285s
	Down	Idle	75 to 95s	225 to 285s
Arm 3	Up	Idle	15 to 25s	45 to 75s
		High regime	35 to 45s	105 to 135s
	Down	Idle	15 to 25s	45 to 75s
		High regime	25 to 35s	75 to 105s
Upper telescope	Out	Idle	75 to 95s	225 to 285s
		High regime	15 to 25s	45 to 75s
	In	Idle	45 to 55s	135 to 165s
		High regime	15 to 25s	45 to 75s
Orientation (end to end)				
Rotation (end to end)				
<p>Note: The movement speeds may vary according to the telescope position, the adjustment of the limit switches and the adjustment of the load holding valves.</p>				



## Section 2. SAFETY INSTRUCTIONS

### 2.1. GENERAL

You, the operator, are the only part of the machine that can think and reason. Your responsibility is not diminished by the addition of alarm or operating assistance systems. You must avoid a false sense of security when using the machine. The control and alarm devices are there to help you and **NOT** to guide the machine's use..

You, the operator, are the only one responsible for your safety and that of others around you. Act as a **PROFESSIONAL** and respect the safety **RULES**.

This machine must only be used to take people, their tools and their equipment to a place at a height.

This machine may only be used and maintained by trained and authorised personnel. This training must be dispensed by qualified personnel.

The operator must acquire detailed knowledge of this machine's characteristics and operating limits, regardless of their experience with similar equipment.

The operator must read and understand the content of this manual. The manual must be kept in the document holder provided for this purpose on the working platform for later reference.

All operating personnel must be familiar with the machine's emergency commands and operation in the event of an emergency.

The operator must stop using the machine in the event of any incorrect operation or any safety problems concerning the machine or the workplace.

Anyone under the influence of alcohol or drugs or subject to crises, dizziness or loss of control must not use this machine.

#### 2.1.1 OPERATOR TRAINING

The operator training must cover the following points:

- Use and usage limits for the working platform controls, ground controls and emergency controls.
- Operation of the safety systems and procedure if an alarm is triggered.
- Reading and understanding of the warning stickers on the machine.
- Knowledge of current regulations concerning this type of machine. (Classification: Group B – Type 1).
- Sufficient knowledge of how the machine operates to be able to recognise incorrect operation, a fault or a risk of a fault.



**DANGER**



**DO NOT USE THIS MACHINE IF YOU HAVE NOT BEEN TRAINED TO USE IT SAFELY. TRAINING COVERS KNOWLEDGE OF YOUR EMPLOYER'S WORKING REGULATIONS, THE INSTRUCTIONS IN THIS MANUAL AND THE CURRENT REGULATIONS THAT APPLY TO THIS TYPE OF MACHINE**



## OPERATOR AND SAFETY MANUAL



- Inspection and controls before start-up.
- Risks related to using the machine near overhead obstacles, other moving machines, holes, obstacles on the ground and tilt.
- Risks related to using the machine near conductors or powered electrical equipment.
- Use of an approved fall-protection mechanism.
- Safety requirements related to a task or specific use of the machine.

### 2.1.2 INSPECTION OF THE WORK PLACE

- Before using the machine, the operator must take precautions to avoid any risk in the workplace:
  - Locate the hazardous locations in the working area.
  - Locate the overhead obstacles, electrical lines, overhead cranes, cranes or other elements.
  - Identify on the ground the presence of holes, bumps, tilt, debris and coatings likely to hide holes or other dangers.
  - Check that the ground is able to support the load of the tracks and outriggers.
- The machine must only be used in well-ventilated premises.
- The machine must be used with sufficient ambient lighting.
- The platform must not be raised if the machine is on the platform or trailer of a truck, on a train, a ship or any other mobile or non-stabilised structure.
- Do not operate the machine in hazardous environments unless approved for that purpose by ATN.
- DO NOT use the machine in presence of electromagnetic fields (radar, high voltage currents...). This could damage the machine's electronic components

### 2.2. TIPPING HAZARDS

- Never exceed the work platform's load capacity. Distribute the load evenly across the platform floor.
- Keep the load inside the work platform. Do not suspend a load from any part of the platform or lifting structure. Do not place a load on the guard rail.
- Check that the ground is able to support the load of the tracks and outriggers.
- Do not drive the machine on slopes or tilts that exceed the maximum acceptable incline.
- Do not raise the platform or move with the platform on inclines, hilly or loose surfaces. Always make sure that the machine is on a firm and even surface before raising the work platform or moving with the platform raised.
- Keep the machine a good distance from holes, bumps, tilt, debris and coatings likely to hide holes or other dangers on the ground.
- Do not raise the work platform if the wind speed is greater than 12.5m/s (45km/h).



## OPERATOR AND SAFETY MANUAL



- Do not transport panels or large elements when the machine is used outdoors: these elements increase the wind surface and reduce the machine's stability.
- Do not pull or push an element outside the work platform. Acceptable manual force (total): 400N
- Do not use the machine as a crane.
- Do not use the machine to pull or push any objects.
- Do not attach the machine to any neighbouring structure. Never use any part of the machine to stabilise or support any structure. Do not attach any electrical wires or other cables to the platform.

### 2.3. CRUSHING AND COLLISION HAZARDS

- When the machine is moving, keep all parts of the body inside the platform guard rail.
- Prevent any obstacles from hitting or hindering the controls or people onboard the platform.
- Make sure that you do not lower the platform onto any tall obstacles. It is recommended that you retract the telescope before lowering the platform.
- Warn the other occupants of the platform before controlling a movement and obtain their approval where necessary.

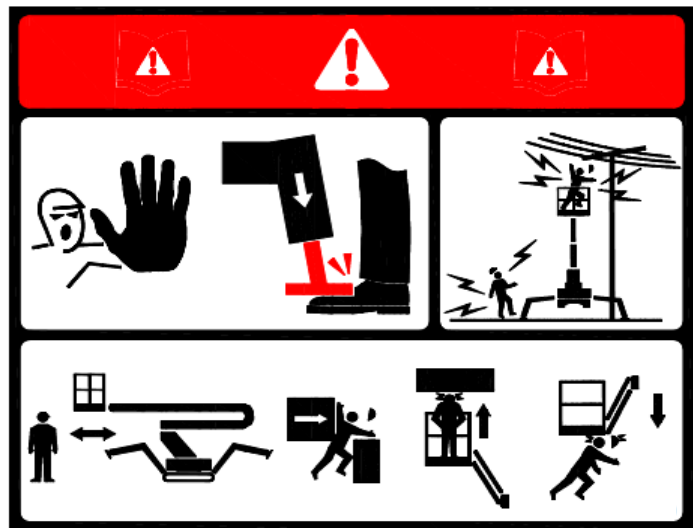

- Make sure that non-operating personnel are kept out of the area where the machine is working. Warn personnel on the ground to keep away from under the platform when it is raised.
- Make sure that the operators of other machines at a height and on the ground are alerted to the lifting platform's presence. If necessary, barricade the area where the machine is working and cut the power to overhead cranes.
- Note the presence of any obstacles around, above and below the platform before controlling a movement.
- Adapt the movement speed according to the condition of the ground, the incline, the visibility, the presence of people in the working area, obstructions on the machine's route and any other factors likely to cause a collision or injury.
- Be guided by a person on the ground when visibility is reduced.
- Take into account the braking or stopping distances according to the movement speed. Reduce speed when moving on slopes (platform in low position).
- The wearing of protective equipment is recommended.
- When using the mobile upper control box, unfold the spiral cord to the maximum to be as far away as possible from the machine (platform, tracks...) and from the moving parts (engine, structure...).



**OPERATOR AND SAFETY MANUAL**



**2.4. ELECTROCUTION HAZARDS**

- This machine is not insulated and does not offer any protection when near or in contact with an electric current.
- Maintain a minimum safety distance in relation to electric lines (insulated or otherwise) or powered devices. The minimum distances indicated in the table below are provided for information purposes. Regulations specific to the country or site where the machine is used may demand greater safety distances.
- Take into account the machine's movements and possible sway of the electric lines.
- Never raise the platform during a storm or lightning.
- Only approved personnel can perform maintenance work on the electrical box of the electric motor. In any case, access to this electrical box (maintenance or else) must be restricted to an approved person (electrocution hazard).

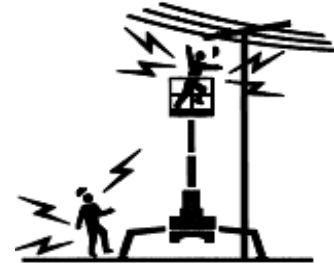

Phase to phase voltage	Minimum safe distance
0 to 300 V	Avoid contact
300 V to 50 KV	3.05 metres
50 KV to 200 KV	4.60 metres
200 KV to 350 KV	6.10 metres
350 KV to 500 KV	7.62 metres
500 KV to 750 KV	10.67 metres
750 KV to 1000 KV	13.72 metres



**DANGER**



NEVER MOVE THE MACHINE OR MOVE PERSONNEL NEAR ELECTRICAL CABLES OR EQUIPMENT.

ALWAYS ASSUME THAT THE ELECTRICAL CABLES OR APPLIANCES ARE LIVE UNLESS YOU ARE SURE THAT THE POWER HAS BEEN CUT.

PERSONNEL ON THE GROUND MUST KEEP AWAY IF THE MACHINE IS BEING USED NEAR ELECTRIC LINES OR POWERED EQUIPMENT.

IN THE EVENT OF CONTACT WITH AN ELECTRIC LINE OR POWERED APPLIANCE, PERSONNEL ON THE GROUND MUST KEEP AWAY FROM THE MACHINE UNTIL THE ELECTRIC POWER IS CUT.





## 2.5. FALLING HAZARDS

- It is recommended that anyone on the platform wears a safety harness connected to one of the hooking points provided for this purpose on the work platform. Only attach one harness to one hooking point.
- Check the condition of the guard rail before you use the machine. Check that the access rail drops back correctly into closed position.
- Keep both feet flat on the platform floor at all times. Do not sit or climb onto the guard rails. Do not use a ladder or climb onto any objects on the platform to reach a greater height.
- When the platform is in raised position, do not use the lifting structure to leave the platform.
- Do not leave or access the work platform until it is fully lowered.
- Remove all debris, grease or any other slippery substance from shoes and from the toe-boards and floor of the platform.
- Always face the machine when accessing or leaving the machine. Keep 3 contact points with the machine at all times: both hands and one or both feet and one hand.

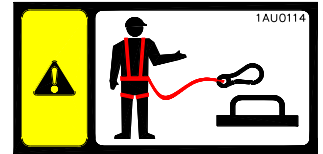

## 2.6. OTHER RISKS

- During welding operations from the platform, do not use the machine as earth.
- During welding or metal cutting operations, make sure that you protect the machine's components from projections of fusing metal (control station, electric cables, hydraulic hoses, cylinders, etc.). Avoid any protection on/to the machine, in particular to the fuel tank.

## 2.7. OPERATION LIMITS

Model	Mygale 23
Max. floor height	20.85 m
Max. working height	22.85 m
Max. number of people in the platform	2
Max. load on the platform (distributed)	230kg
Max. wind speed	12.5m/s (45km/h)
Max. manual force	400 Newton
Max. slope (see Note)	32%
Operating temperature	-20 ... +60°C

**- NOTE-**

**Do not run the diesel engine for over 10 minutes with a tilt or slope of over 32%.**



## OPERATOR AND SAFETY MANUAL



### 2.8. TOWING, LIFTING, TRANSPORT

- Do not tow, lift or transport the machine with people or material on the work platform.
- Fully lower the platform before towing, lifting or transporting the machine.
- The machine must only be towed or lifted in the event of an emergency, a malfunction, a fault or for loading/unloading. Refer to 4.7. HANDLING – STOWAGE FOR TRANSPORT.
- Check the capacity of the equipment used to tow, lift or transport the machine.

### 2.9. MAINTENANCE

- To guarantee the machine's safety, a maintenance and inspection programme taking into account the information provided in this manual and in the maintenance manual must be established by a qualified person.
- Before performing any maintenance or repair operations, cut the power to the control stations.
- Never work under the work platform or on the lifting structure without it being supported and immobilised by appropriate slinging.
- Disconnect the battery during interventions on the machine's electrical circuit or during welding operations.
- Do not smoke, bring in bare flames or create sparks near the battery.
- Do not place any metal tools or objects on the battery terminals.
- The acid contained in the battery is highly corrosive. Make sure that it does not come into contact with skin, eyes or clothing. Wear appropriate protective equipment when maintaining the battery.
- Only recharge the battery in well-ventilated premises.
- Avoid any projections or do not drop any flammable products onto the diesel engine's hot parts (mainly the collector and exhaust).
- Never intervene on a pressurised hydraulic circuit or component: let the pressure drop before dismantling or loosening any components.
- Only use spare parts or components that are identical to the original ones.
- Avoid working on the diesel engine when it is running. If this cannot be avoided, do not wear loose clothing and tie back long hair to ensure it is not caught by moving parts. Do not intervene near moving parts (fan, alternator, fan belt, etc.).
- Do not open the radiator cap when the engine is hot.
- No modifications may be made to this machine without written agreement from the manufacturer (**ATN**). These modifications will invalidate the warranty and the owner and/or user will be held responsible if an accident occurs.



## Section 3. PREPARATION AND INSPECTION

Before use, careful inspection and operating check are recommended to ensure the machine is in perfect working order.

Do not use the machine if it is damaged or has an operating defect.

Depending on national or local regulations, the machine must be submitted for periodic verifications and testing.



**DANGER**



FAILURE TO PROPERLY MAINTAIN AND CHECK THIS MACHINE MAY RESULT IN DEATH OR SERIOUS INJURIES.

THIS MACHINE MUST NOT BE USED IF IT IS NOT IN PERFECT WORKING ORDER.

### **3.1. INSPECTION BEFORE START UP**

- 1- Check the machine for oil or fuel leaks. Check the machine's general cleanliness (slippery substances on the platform floor).
- 2- Inspect the machine's structure to detect any damaged parts, cracked welds or any other defect.
- 3- Check the presence and legibility of the safety stickers. Clean or replace any illegible stickers.
- 4- Check that there is a copy of the operator and safety manual in the work platform's document holder.
- 5- Carry out the inspection tour described below.

Carry out the operating checks described below

### **3.2. INSPECTION TOUR**

Check in order each element in the list below. For each element, in addition to the criteria mentioned, check that no parts are loose or missing, that the elements are correctly attached and that they have no leaks or visible damage.

- 1- Diesel engine and accessories: Oil level, cooling fluid level – Hydraulic pumps.
- 2- Electric motor : link between the plug and the electric motor
- 3- Electric cables – Cable travel and tightening of the battery connections.
- 4- Presence of the lock pins on the outrigger pins.
- 5- Operating check of the outrigger locking system.
- 6- Presence of the motor reducer screw.
- 7- Tracks: Tracks in good condition – Track correctly tightened (Refer to section 7.3 TRACKS)



## OPERATOR AND SAFETY MANUAL



- 8- Hydraulic compartment: No leak on the hydraulic manifolds. Connections on the hydraulic control valves and sensors correctly installed / connected – No electric cable damaged.
- 9- Tanks: No leak on the tanks. Fuel level – Presence of the fuel tank filling cap – Hydraulic oil level in the tank correct – Presence of the hydraulic tank filling cap.
- 10- Ground control station: The control station switches are present and return to neutral position – The emergency stop switch is operating correctly.
- 11- Structure position sensor, outrigger position sensor.
- 12- Hydraulic cylinders.
- 13- Articulation pins: lock pin screws present.
- 14- Guard rail: condition – Access rail drops down correctly.
- 15- Platform control stations: Correctly secured - The levers and switches are present and return to neutral position – The validation pedal is correctly attached and is operating correctly. The emergency stop switch is operating correctly.

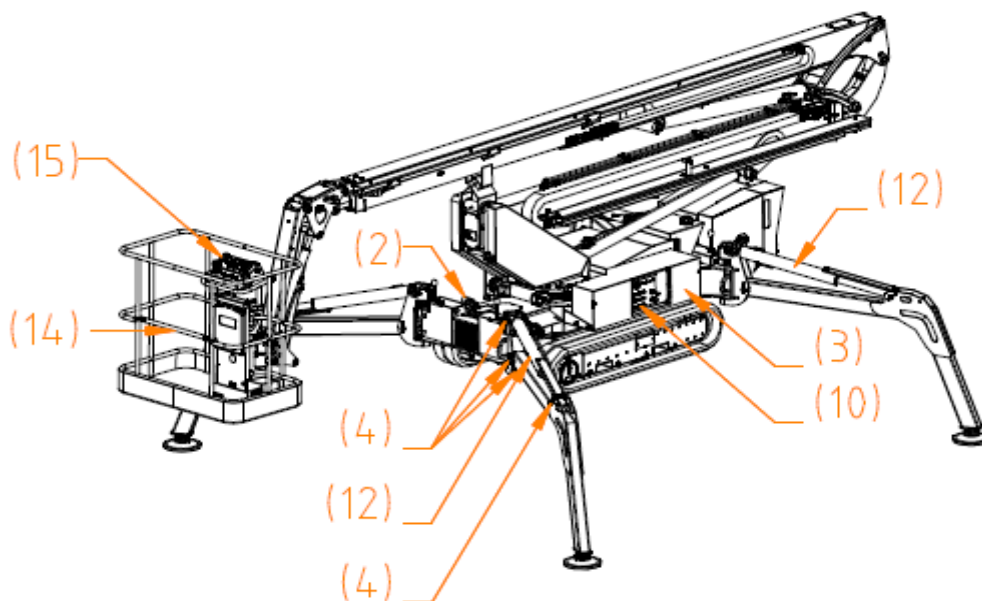



OPERATOR AND SAFETY MANUAL

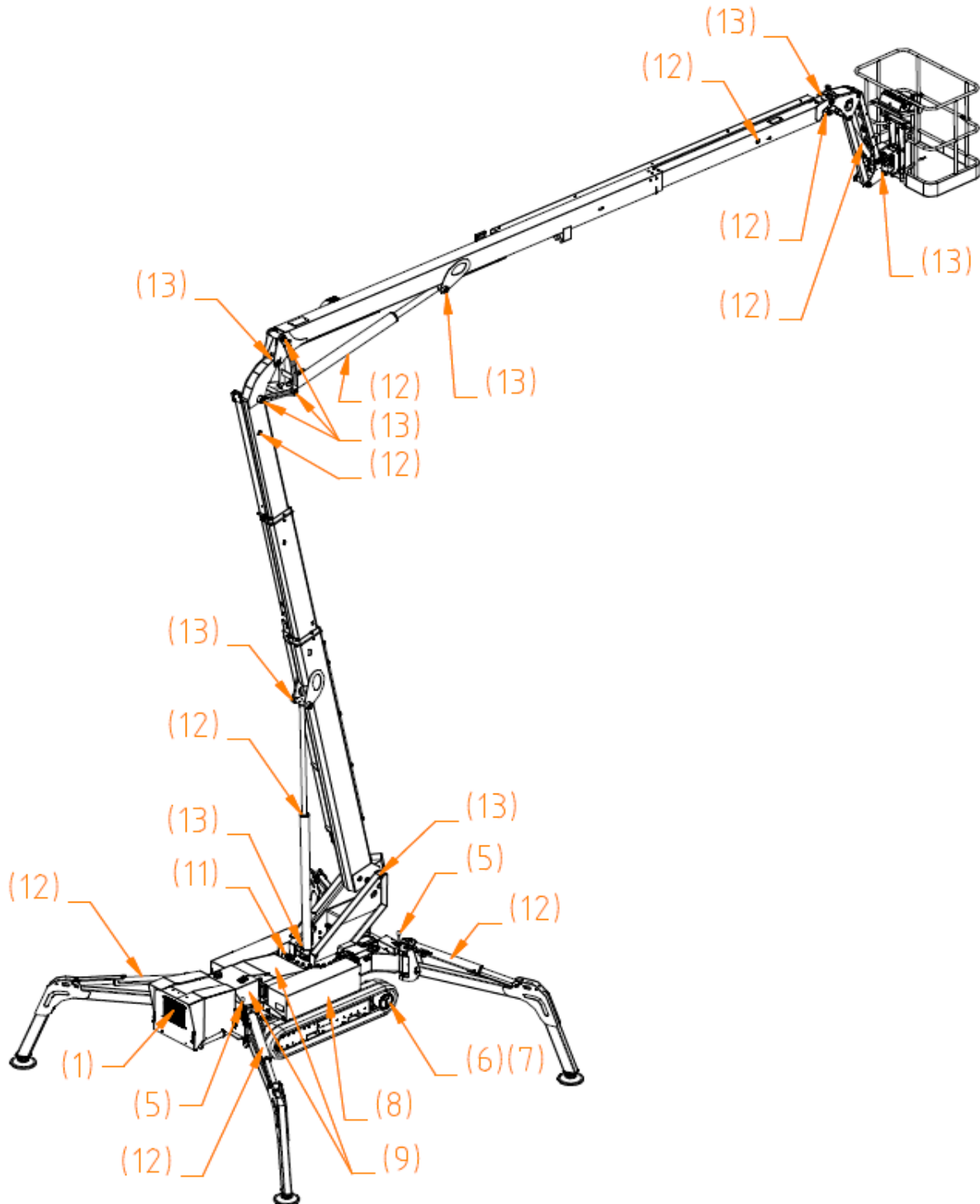



### **3.3. OPERATING CHECKS**

Machine operation: Refer to Section 4. OPERATION.

#### **3.3.1 CONTROL STATIONS**

- **Ground Control Station**

- 1- On power up, check the indicators light up and the good working order of the alarm (Autotest).
- 2- Start the heat engine or electric motor and activate all the controls to check their good working order. Check the movement stops when the control is released. Check the movement stops when the enable button is released.
- 3- Check the emergency stop switch cuts all the movements as well as the heat engine or the electric motor (the heat engine stops after about 2 seconds).
- 4- Heat engine (electric motor) stopped, check the good working order of the electric motor (heat engine).

- **Platform Controls Stations**

- 1- On power up, check the indicators light up and the good working order of the alarm (Autotest).
- 2- Start the heat engine or electric motor and activate all the controls to check their good working order. Check the movement stops when the control is released. Check the movement stops when the enable pedal is released.
- 3- Check the machine switches to slow speed when the work platform is raised.
- 4- Check the machine switches to slow speed when the telescope is extended.
- 5- Check the emergency stop switch cuts all the movements as well as the heat engine or the electric motor (the heat engine stops after about 2 seconds).
- 6- c).

#### **3.3.2 TILT INDICATOR**

- 1- Platform lowered, drive the machine on a slope greater than 15%: the tilt light comes on.
- 2- Flashing ground contact indicator (ground contact condition and  $-0.2^\circ < \text{tilt} < 0.2^\circ$  not fulfilled), the control of the structure elevation results in the actuation of the alarm and the elevation function is disabled.
- 3- Once the machine is raised, if the tilt exceeds  $1.5^\circ$  the tilt indicator will light up. If the tilt exceeds  $1.5^\circ$  the alarm comes on and only the lowering movements and telescope retraction movements are allowed.
- 4- Check the movements are disabled depending on the selected operating mode (refer to Section 5: SAFETY DEVICES).



## Section 4. OPERATION

This machine is a Mobile Elevating Work Platform intended to take to a work station at height, personnel, tools and materials **NEEDED** to carry out work **FROM** the platform. Contact the manufacturer for any information about a specific use or working condition.

The machine has a main control station on the work platform which is used to command the elevation and drive movements.

A priority control station on the ground is used to raise or lower the platform in the event of an emergency, when the operator on the work platform cannot operate the machine. Except for an emergency, the ground control station must not be used when people are on-board the work platform.

Read the safety instructions in Section 2. of this manual before using the machine.



OPERATOR AND SAFETY MANUAL



4.1. CONTROLS AND INDICATORS

4.1.1 GROUND CONTROL STATION

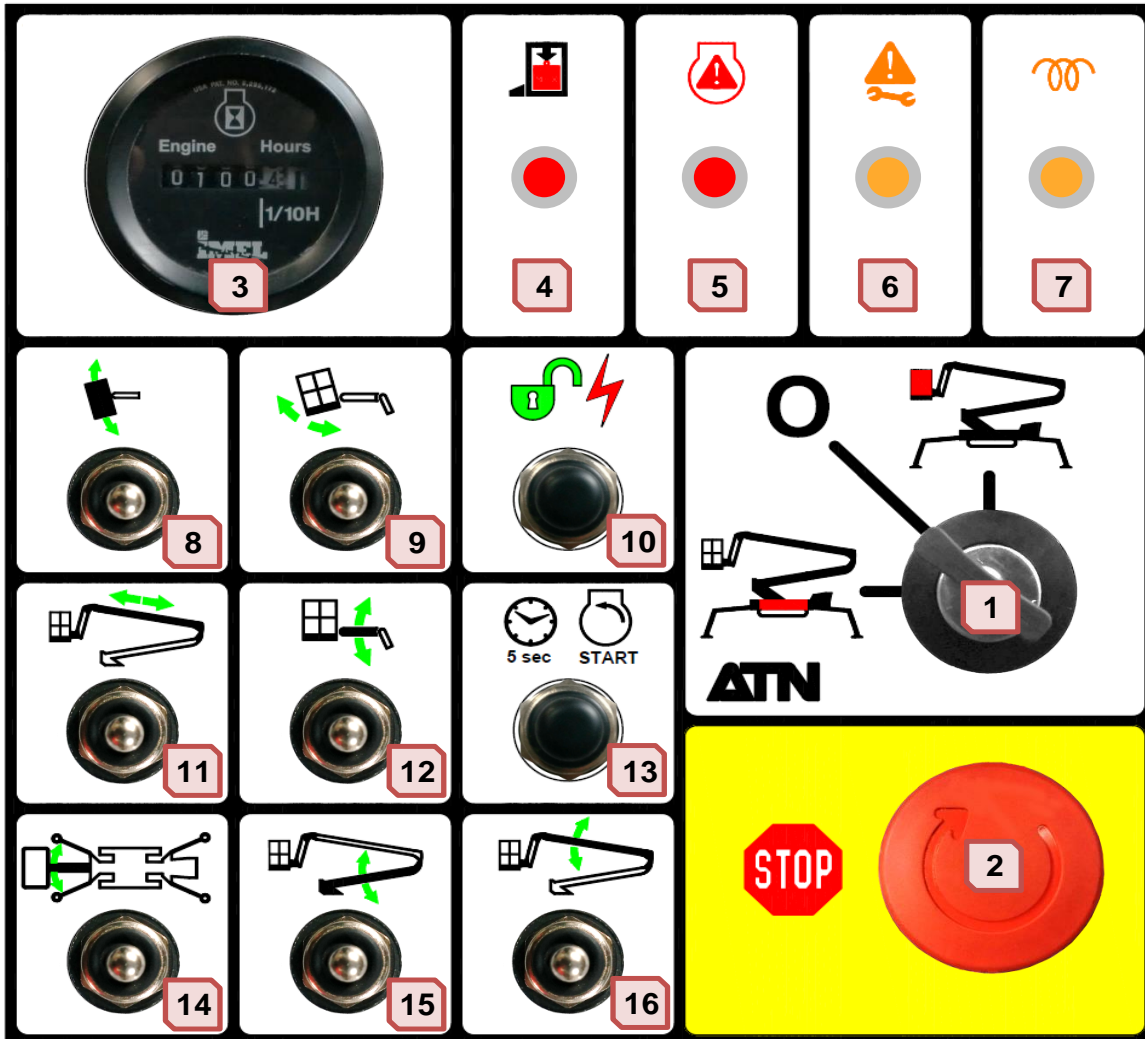

- 1- Control station selector / Machine cut out switch.
- 2- Emergency Stop switch.
- 3- Hourmeter.
- 4- Overload indicator.
- 5- Engine fault indicator.
- 6- System fault / Maintenance indicator.
- 7- Preheat indicator.
- 8- Left / Right platform rotation.
- 9- Up / Down platform levelling control.
- 10- Enable button
- 11- Upper telescope In / Out control
- 12- Jib 3 Up / Down control.
- 13- Heat engine and electric motor start button.
- 14- Left / Right Orientation control.
- 15- Arm 1 Up / Down control.
- 16- Arm 2 Up / Down control.





OPERATOR AND SAFETY MANUAL



	<p><u>1- Control station selector:</u> Used to activate the controls from the platform control station or from the ground control station. In position O, the key can be removed to power the machine down.</p>
	<p><u>2- Emergency Stop Switch:</u> In the event of an emergency, PRESS the button to CUT all the movements from the machine and shut down the heat engine or the electric motor. Turn the button by a 1/4 to restore the electrical power.</p>
	<p><u>3- Hourmeter:</u> Indicates the total operating time for the heat engine.</p>
	<p><u>4- Overload indicator:</u> This light flashes when the work platform's load capacity is exceeded. Refer to Section 5.2 LOAD CONTROL</p>
	<p><u>5- Engine Fault Indicator:</u> This light comes on power up and must go out when the engine starts. When the engine is running, this light flashes if there is an alternator fault: the alternator is no longer correctly recharging the battery. When the engine is running, this light comes on steady when the heat engine oil pressure is abnormally low or when the cooling fluid temperature is abnormally high: CUT the engine as quickly as possible. Refer to section 4.2.3. HEAT ENGINE SAFETIES</p>
	<p><u>6- System fault / Maintenance indicator:</u> This light flashes slowly when a maintenance / pre-scheduled maintenance operation is required. This light is on steady (and a alarm sounds) if there is a control system fault. Refer to section 5.3 SYSTEM FAULT.</p>
	<p><u>7- Preheat indicator:</u> This light comes on during the preheating phase and goes off once the engine starts. Refer to Section 4.2 HEAT ENGINE OPERATION.</p>
	<p><u>8- Platform rotation control:</u> Toggle the switch upwards to move the platform to the right or downwards to move the platform to the left. Refer to Section 4.5.2 ELEVATION .</p>



OPERATOR AND SAFETY MANUAL



	<p><u>9- Up / Down platform levelling control:</u> Toggle the switch up to adjust the platform level upwards or down to adjust the platform level downwards. Refer to Section 4.5.4. PLATFORM LEVELLING</p>
	<p><u>10- Enable button:</u> Control validation: When the heat engine or the electric motor is running, toggle and hold the switch downwards to enable the movement controls.</p>
	<p><u>11- Upper telescope In / Out control:</u> Toggle the switch to the left to extend the telescope or to the right to bring it back in. Refer to Section 4.5.3 TELESCOPE.</p>
	<p><u>12- Jib3 Up / Down control:</u> Toggle the switch upwards to raise the jib 3 or downwards to lower the jib 3. Refer to Section 4.5.2 ELEVATION .</p>
	<p><u>13- Heat engine or electric motor start button:</u> Starting the heat engine or the electric motor: toggle and hold the lever upwards until the motor starts. Once the heat engine has started, this button is used to validate the upper controls when operating the machine from the mobile control station (outriggers + drive). Refer to Section 4.2 HEAT ENGINE OPERATION.</p>
	<p><u>14- Right / Left Orientation control:</u> Toggle the lever upwards to move the structure to the right or downwards to move the structure to the left. Refer to Section 4.5.5 STRUCTURE ORIENTATION</p>
	<p><u>15- Arm 1 Up / Down control:</u> Toggle the lever upwards to raise arm 1 or downwards to lower arm 1. Refer to Section 4.5.2 ELEVATION .</p>
	<p><u>16- Arm 2 Up / Down control:</u> Toggle the lever upwards to raise arm 2 or downwards to lower arm 2. Note : It is recommended to retract the telescope beforehand. Refer to Section 4.5.2 ELEVATION.</p>



OPERATOR AND SAFETY MANUAL



4.1.2 PLATFORM MOBILE CONTROL STATION

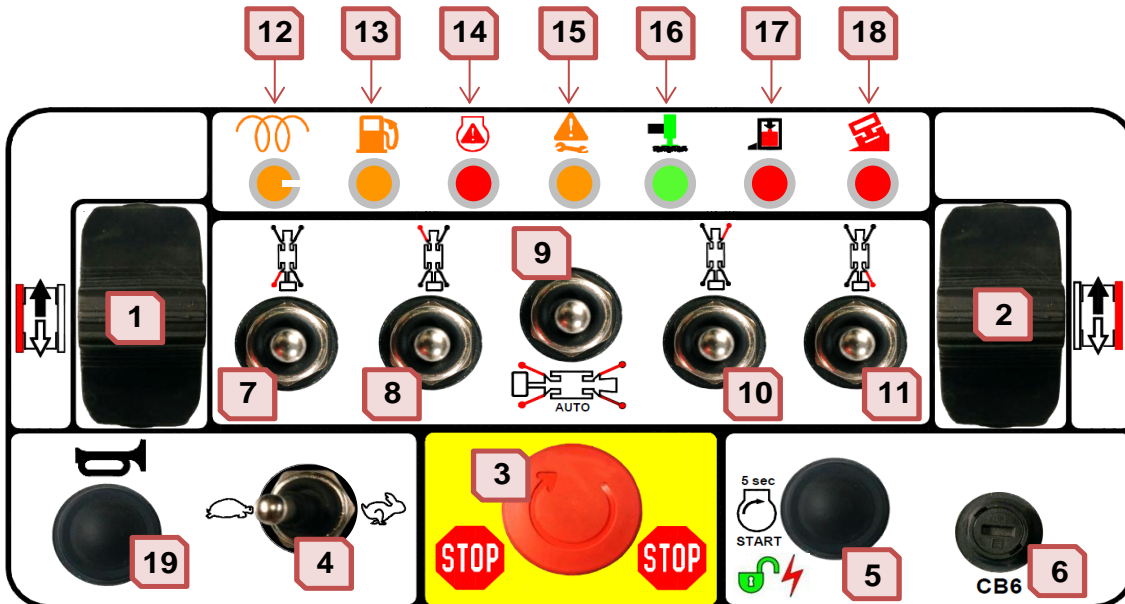

- 1- Drive control joystick - Left Track.
- 2- Drive control joystick - Right Track.
- 3- Emergency Stop Switch.
- 4- Drive speed selector switch.
- 5- Start button – Heat engine or electric motor.
- 6- Mobile Upper Control Station XC21 protection fuse.
- 7- Up / Down control – Outrigger 1 (Rear Left).
- 8- Up / Down control – Outrigger 2 (Front Left).
- 9- Up / Down control – All outriggers until complete stabilization of the machine.
- 10- Up / Down control – Outrigger 3 (Front Right).
- 11- Up / Down control – Outrigger 4 (Rear Right).
- 12- Preheat indicator
- 13- Fuel level indicator
- 14- Engine fault indicator
- 15- System fault / Maintenance Indicator
- 16- Indicator - Outrigger ground contact
- 17- Overload indicator
- 18- Tilt Indicator
- 19- Horn



**OPERATOR AND SAFETY MANUAL**



	<p><b>1- Drive Control Joystick – Left Track:</b> Push the joystick towards the front or to the rear to move the left track in the direction indicated by the arrows (in the event of a structure rotation, reminders of the drive direction are added on the chassis of the machine). Refer to section 4.4. DRIVE -</p>
	<p><b>2- Drive Control Joystick – Right Track:</b> Push the joystick towards the front or to the rear to move the right track in the direction indicated by the arrows (in the event of a structure rotation, reminders of the drive direction are added on the chassis of the machine). Refer to section 4.4. DRIVE -</p>
	<p><b>3- Emergency Stop Switch:</b> In case of an emergency, PRESS the button to CUT all the machine's movements and shut down the heat engine. Turn the button by a 1/4 turn to restore the electrical power.</p>
	<p><b>4- Start Button – Heat engine or electric motor:</b> Start of the heat engine or electric motor : tilt upwards and hold the switch until the motor starts. Refer to Section 4.2 HEAT ENGINE OPERATION and 4.3 ELECTRIC MOTOR OPERATION</p>
	<p><b>5- Drive Speed Selector Switch:</b> This 2-position switch is used to select the maximum drive speed:   : Slow speed   : When authorised by the control system, the structure and drive movements will be performed at high speed, heat engine at high regime. Refer to Section 4.2.2. ENGINE SPEED.</p>
	<p><b>6- Mobile Upper Control Station XC21 protection fuse:</b> Unscrewable fuse to replace in case of an electrical problem only.</p>
	<p><b>7- Up / Down control – Outrigger 1 (Rear Left):</b> 3-position switch to control the elevation and lowering of the outrigger 1: Toggle the switch upwards to lower the outrigger 1 (raise the machine) or downwards to raise the outrigger 1 (lower the machine). Refer to section 4.8 OUTRIGGERS</p>
	<p><b>8- Up / Down control – Outrigger 2 (Front Left):</b> 3-position switch to control the elevation and lowering of the outrigger 2: Toggle the switch upwards to lower the outrigger 2 (raise the machine) or downwards to raise the outrigger 2 (lower the machine). Refer to section 4.8 OUTRIGGERS</p>



OPERATOR AND SAFETY MANUAL



	<p><u>9- Up / Down control – All outriggers until complete stabilization of the machine:</u> 3-position switch to automatically level and lower the outriggers: Push the button upwards to activate the automatic levelling of the outriggers (raise the machine) or downwards to activate the automatic lowering of the outriggers. Refer to section 4.8. OUTRIGGERS</p>
	<p><u>10- Up / Down control – Outrigger 3 (Front Right):</u> 3-position switch to control the elevation and lowering of the outrigger 3: Toggle the switch upwards to lower the outrigger 3 (raise the machine) or downwards to raise the outrigger 3 (lower the machine). Refer to section 4.8. OUTRIGGERS</p>
	<p><u>11- Up / Down control – Outrigger 4 (Rear Right):</u> 3-position switch to control the elevation and lowering of the outrigger 4: Toggle the switch upwards to lower the outrigger 4 (raise the machine) or downwards to raise the outrigger 4 (lower the machine) Refer to section 4.8. OUTRIGGERS</p>
	<p><u>12- Preheat indicator :</u> This light comes on during the preheating phase and goes off once the engine starts. Refer to Section 4.2. HEAT ENGINE OPERATION</p>
	<p><u>13- Fuel level indicator:</u> This indicator lights up when the fuel level in the tank reaches a critical level: add fuel in the tank.</p>
	<p><u>14- Engine fault indicator:</u> This indicator lights up on ignition and must go out when the engine starts. When the engine is running, the light flashes if there is an alternator fault (the alternator is no longer correctly recharging the battery). When the engine is running, the light comes on steady when the heat engine oil pressure is abnormally low or when the cooling fluid temperature is abnormally high: CUT the engine as quickly as possible. Refer to Section 4.2.3. SAFETIES HEAT ENGINE</p>



**OPERATOR AND SAFETY MANUAL**



	<p><u>15- Fault System / Maintenance indicator:</u> This light flashes slowly when a service / pre-scheduled maintenance operation is required. This light is on steady (and an alarm sounds) if there is a control system fault. Refer to section 5.3. SYSTEM FAULT.</p>
	<p><u>16- Indicator – Outrigger Operation and Ground Contact:</u> This light flashes when the levelling mode (automatic or manual) is activated as well as during the movement of the outriggers. This light is lit on steady when all four outrigger are in contact with the ground. Refer to section 4.8. OUTRIGGERS</p>
	<p><u>17- Overload indicator:</u> This light flashes when the work platform's capacity is exceeded. Refer to Section 5.2. LOAD CONTROL</p>
	<p><u>18- Tilt indicator:</u> The light flashes when the outriggers are in motion. The light is on steady when the machine is on a slope exceeding the maximum tilt allowed or when the chassis is tilted beyond its admissible tilt. Refer to 0SAFETY DEVICES</p>
	<p><u>19- Horn :</u> This switch is used to warn people around the machine of its presence.</p>



**DANGER**



IF THE TILT INDICATOR LIGHT COMES ON AND AN ALARM SOUNDS WHEN THE WORK PLATFORM IS RAISED, IMMEDIATELY LOWER THE PLATFORM, STARTING BY BRINGING THE UPPER TELESCOPE BACK IN.



**CAUTION**



An elevation movement cannot be controlled using the fixed platform control station if the mobile platform control station is not on its support on the work platform.



OPERATOR AND SAFETY MANUAL



4.1.3 PLATFORM FIXED CONTROL STATION

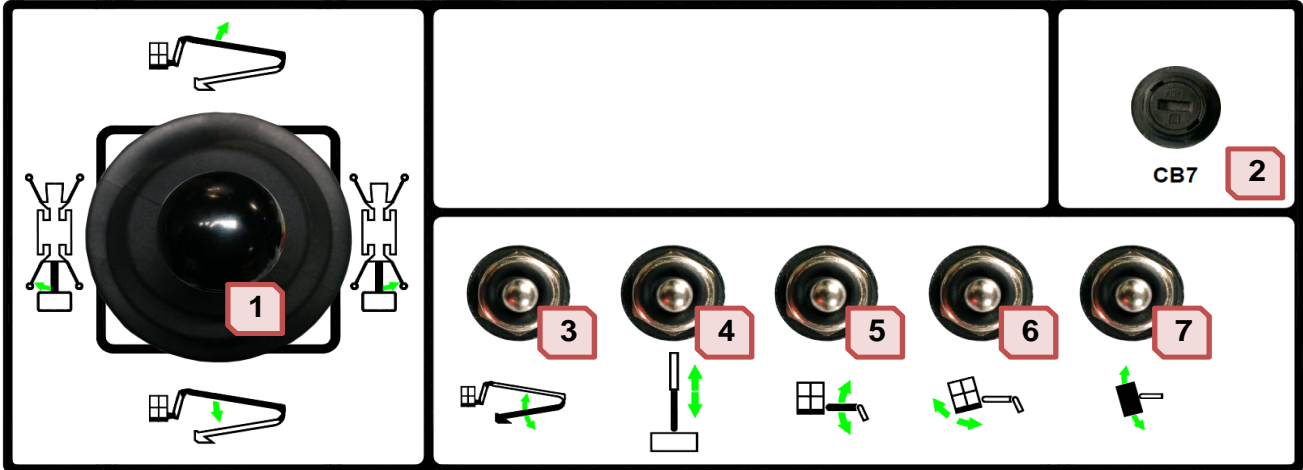

- 1- Arm 2 Up / Down and Orientation Joystick
- 2- Fixed Upper control station XC21 Protection Fuse.
- 3- Arm 1 Up / Down Control.
- 4- Upper Telescope In / Out Control.
- 5- Jib 3 Up / Down Control.
- 6- Platform Up / Down Levelling Control.
- 7- Right / Left Platform Rotation Control.



OPERATOR AND SAFETY MANUAL



	<p>1- <u>Arm 2 Up / Down and Orientation Joystick:</u>          Push the lever forward to raise the Arm 2 or pull it backwards to lower the Arm 2          Tilt the lever to the right to swing the structure in an anticlockwise direction or to the left to swing the structure clockwise.</p>
<p>CB7</p>	<p>2- <u>Fixed Upper control station XC21 Protection Fuse:</u>          Unscrewable fuse to replace in case of an electrical problem only.</p>
	<p>3- <u>Arm 1 Up / Down Control:</u>          Toggle the switch upwards to raise the arm 1 or downwards to lower the arm 1.          Refer to Section 4.5.2 ELEVATION .</p>
	<p>4- <u>Upper Telescope In / Out Control:</u>          Toggle the switch upwards to bring the upper telescope in or downwards to extend the upper telescope.          Refer to Section 4.5.3 TELESCOPE.</p>
	<p>5- <u>Jib 3 Up / Down Control:</u>          Toggle the switch upwards to raise the arm 3 or downwards to lower the arm 3.          Refer to Section 4.5.2 ELEVATION .</p>
	<p>6- <u>Platform Up / Down Levelling Control:</u>          Toggle the switch up to adjust the platform level upwards or down to adjust the platform level downwards.          Refer to Section 4.5.4.PLATFORM LEVELLING</p>
	<p>7- <u>Platform Rotation Control:</u>          Toggle the switch upwards to move the platform to the right or downwards to move the platform to the left.          Refer to Section 4.5.2 ELEVATION .</p>





## 4.2. HEAT ENGINE OPERATION

### -NOTE-

The heat engine and the electric motor are two equivalent propulsion sources in terms of operation (the electric motor is not the auxiliary power group). During operation, the electric motor becomes the auxiliary source for the heat engine and vice-versa. Remember to plug in the electric motor and ensure the voltage is not below 220V.

The heat engine will only start if the 220V is not connected to the mains. If connected to the mains, the electric motor will start.

### 4.2.1 STARTING / STOPPING

#### -NOTE-

Check the level of engine oil and of cooling fluid before starting the heat engine. The heat engine will not start if the electric motor is in operation.

- **Control station selector**

The heat engine may only be started from the control station selected.

#### -NOTE-

To start the engine from the control station on the ground, the emergency stop on this station must be unlocked.

To start the engine from the platform control station, the emergency stops on both control stations must be unlocked.

If the engine was started from the control station on the ground and the Emergency Stop on the platform station is pushed in, the heat engine will cut off when selecting a different control station.

#### -NOTE-

The engine may only be started if all the commands are in neutral and the enable pedal is released.

The heat engine cannot start as long as the mains socket is connected to the electric box of the electric motor.

- **Start up from the ground control station**

Push and hold the start button until the heat engine starts.

Check the engine fault indicator light goes out once the engine has started.

- **Starting from the platform mobile control station**

Push and hold the start button until the heat engine starts.

Check the engine fault indicator light goes out once the engine has started.



IF THE ENGINE DOES NOT START UP IMMEDIATELY, DO NOT KEEP ACTIVATING THE STARTER MOTOR FOR A LONG PERIOD OF TIME. RELEASE THE START BUTTON AND TRY AGAIN.

IF THE ENGINE FAILS TO START AGAIN, LET THE STARTER MOTOR COOL DOWN FOR 1 TO 2 MINUTES.

IF THE ENGINE STILL DOES NOT START AFTER SEVERAL ATTEMPTS, CONSULT THE ENGINE MAINTENANCE MANUAL.



## OPERATOR AND SAFETY MANUAL



- **Starting from the platform fixed control station**

Press and hold the enable pedal until the heat engine starts.

Check the engine fault indicator light goes out once the engine has started.

- During a cold start, the preheating phase lasts 5 to 10 seconds before the engine starts (the preheating light is on). Hold the button down for 1 to 2 seconds after the engine starts.

- When the engine is hot it starts immediately. Release the button as soon as the engine starts.





LET THE ENGINE WARM UP FOR A FEW MINUTES BEFORE USING THE MACHINE.



- **Stopping / Emergency stop**

Pressing the Emergency Stop switch cuts the power to the controls and stops the heat engine. From the control station on the ground, the engine may be stopped by turning the control station selector to position O.

### 4.2.2 ENGINE SPEED

The engine speed is managed by the control system according to the movements performed and/or the activation of certain safeties.

During a drive movement, with the platform in low position, the engine runs at high speed when the speed selector is positioned on . The engine remains idle when slow speed  is selected.

From the platform control station, when the engine speed selector is positioned on , the elevation movements will be carried out at high speed if the control system permits it. If the selector is positioned on , all the movements will be carried out with the engine slowed down.

From the control station on the ground, all the movements are carried out with the engine slowed down.

### 4.2.3 HEAT ENGINE SAFETIES

When one of the following faults is detected:

- Oil pressure too low.
- Cooling fluid temperature too high.
  - The engine fault light comes on steady.
  - The control system prevents the change to high speed.

Return the platform to its low position and stop the engine immediately. The electric motor may also be used to lower the platform.

The exact nature of the fault is indicated on the control module screen.



### 4.3. ELECTRIC MOTOR OPERATION

**-NOTE-**

The heat engine and the electric motor are two equivalent propulsion sources in terms of operation (the heat engine is not the auxiliary power group). During operation, the heat engine becomes the auxiliary source for the electric motor and vice-versa. Ensure the fuel tank is full before operating the machine using the electric motor and follow the instructions described in this section.

**-NOTE-**

The electric motor operates on the mains 210-220V, 50Hz.



**CAUTION**



WHEN PLUGGING THE ELECTRIC MOTOR TO THE MAINS, THE OPERATOR MUST ENSURE A 30mA DIFFERENTIAL CIRCUIT BREAKER IS INSTALLED UPSTREAM FROM THE ELECTRIC MOTOR. THE OPERATOR'S LIFE IS AT STAKE!

#### 4.3.1 *START / STOP*

**-NOTE-**

Ensure the electric motor is plugged into the mains and that the voltage is sufficient for the motor to function properly.

The electric motor will not start if the heat engine is running.

The electric motor does function only when the validation is active or/and when a movement has been activated. Refer to section 4.4. DRIVE-STEERING and 4.5.

- **Starting from the ground control station**

Push and hold the enable button until the electric motor starts.

- **Starting from the platform mobile control station**

**-NOTE-**

Only the actions available on the upper mobile control box can be performed using the enable button.

Push and hold the enable button until the electric motor starts.

- When starting using the enable button, you have 10 seconds to perform a movement. Past this lapse of time, you will have to release and depress the enable button again to restart the electric motor.

- **Starting from the platform fixed control station**

**- NOTE-**

Only the actions available on the upper fixed control box can be performed using the enable button.



- When starting using the enable pedal, the electric motor will run as long as the pedal is depressed. If no movement is controlled within 5 seconds, the electric motor will stop. You will have to release the pedal and press it again to start the electric motor again.



## OPERATOR AND SAFETY MANUAL



### 4.3.2 MOTOR SPEED

The electric motor has only one speed. Selecting mode  or  has not influence on the operating mode of the machine

### 4.3.1 SAFETIES OF THE ELECTRIC MOTOR

The safety of the electric motor is ensured by a thermal circuit breaker.

### 4.4. DRIVE - STEERING

#### • Drive

- 1- Select the work platform control station and start the electric motor or the heat engine.
- 2- Select the drive speed best adapted. Refer to Section 2.3. CRUSHING AND COLLISION HAZARDS
- 3- Joystick in neutral position, activate the enable button on the mobile upper control station or the enable pedal in the work platform.
  - Within 5 seconds, push both drive joysticks forward to drive forward or pull both joysticks to the rear to reverse. The drive speed is proportional to the course of the joysticks. If both joysticks are not activated with the same course, the machine will drive sideways (refer to Section 4.4. Drive – Steering). If the movement is not controlled within 10 seconds, the button must be activated again.
  - To stop the movement, return both joysticks to neutral to reduce the speed.



**DANGER**



THE MACHINE'S ROTATION MAY DAMAGE THE GROUND. ENSURE THE MACHINE IS NOT OPERATED ON LOOSE GROUND AND CHECK THE TRACK CONDITION WHEN USING THE MACHINE INSIDE.  
IF USED ON FRAGILE GROUNDS CHECK FOR STONES STUCK IN THE TRACKS.



**DANGER**



DRIVE THE PLATFORM IN TRANSPORT POSITION ONLY ON EVEN, FIRM AND HORIZONTAL SURFACES..  
TO PREVENT ANY TILTING HAZARD, DO NOT DRIVE THE MACHINE NEAR HOLES OR ON A SLOPE OR TILT GREATER THAN THE VALUES INDICATED IN SECTION 2. .  
WHEN DRIVING, DO NOT TEAR, UNPLUG OR DRIVE OVER THE ELECTRIC CABLE SUPPLYING THE ELECTRIC MOTOR.

#### -NOTE-

When the structure is rotated beyond 90° the drive controls are reversed.

The black and white directional arrows on the pictogram in front of the joystick and those on the machine's chassis are used to identify the drive direction in relation to the direction in which the joystick is moved: activate the joystick in the direction indicated by the arrow corresponding to the drive direction desired.

#### • Steering

To steer the machine, you have 6 different combinations:

- 1- Left track control joystick pushed and right track control joystick pulled: the machine will turn on itself clockwise.
- 2- Left track control joystick pulled and right track control joystick pushed: the machine will turn on itself anticlockwise



## OPERATOR AND SAFETY MANUAL



- 3- Left track control joystick pushed and right track control joystick pulled with a lesser course than the left track joystick : the machine will drive sideways to the left (structure in transport position)
- 4- Left track control joystick pushed and right track control joystick pulled with a greater course than one left track joystick : the machine will drive sideways to the right (structure in transport position)
- 5- Left track control joystick pulled and right track joystick pulled with a lesser course than the left track joystick : the machine will reverse sideways to the right (structure in transport position)
- 6- Left track control joystick pulled and right track joystick pulled with a greater course than the left track joystick : the machine will reverse sideways to the left (structure in transport position).

### -NOTE-

**Activation of only one joystick will not move or only slightly move the machine.**

**Drive forwards means in this case in the direction of the black arrow and reverse in the direction of the white arrow (cf. sticker on the chassis)**

- **Loose grounds, tilt**

If the machine is used on a non-horizontal ground, the operator must leave the work platform and control the drive movement from the mobile control station designed for this purpose. This recommendation applies as soon as the tilt alarm sound or if the operator has planned to drive over a pavement or on a slope.

When using the mobile control box outside the platform, the controls are enabled with the enable button on the mobile control box.

## DANGER

BECAUSE OF THE STRUCTURE OF THE MACHINE, THE OPERATOR MUST LEAVE THE WORK PLATFORM IF DRIVING OVER « DIFFICULT » GROUNDS. FAILURE TO DO SO COULD RESULT IN THE OPERATOR BEING CATAPULTED FROM THE MACHINE AND / OR ADDING A DYNAMIC EFFECT WHICH COULD CAUSE THE MACHINE TO TIP OVER.

IN GENERAL AS SOON AS THE TILT ALARM SOUNDS DURING A DRIVE MOVEMENT, THE OPERATOR MUST LEAVE THE WORK PLATFORM TO CONTROL THE MACHINE. ON A LONGITUDINAL SLOPE, THE MAX. TILT PERMITTED IS 25 %. THE SIDEWAYS SLOPE ALLOWED IS OF 15%.

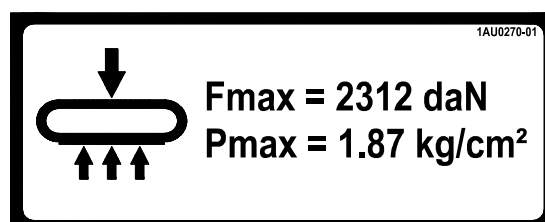

**Most unfavourable configuration**



## OPERATOR AND SAFETY MANUAL



### 4.5. ELEVATING STRUCTURE

#### 4.5.1 ENGINE SPEED

A speed range may be selected for the structure movements with the engine speed selector when using the heat engine. Refer to Section.

The engine high speed for the structure movements must only be used if the machine is being used in an area free of any obstacles. Refer to 2.3. CRUSHING AND COLLISION HAZARDS.

For approach movements, we recommend performing the movements with the engine slowed down.

#### 4.5.2 ELEVATION

- **From the ground control station**

- 1- Depress and hold the enable button.
- 2- Toggle the control switch for Arm 1 or 2 or Jib 3 upwards to raise the corresponding arm / jib. Toggle the control switch for Arm 1 or 2 or Jib 3 downwards to lower the corresponding arm / jib.
- 3- To stop the movement, release the switch or the enable button.

- **From the fixed control station in the platform.**

- 1- Select the engine speed required.
- 2- Activate the validation pedal.
- 3- Within 10 seconds, tilt the arm 1, 2 or 3 control lever upwards to raise the corresponding arm or downwards to lower the corresponding arm.  
The arm 2 movement speed is proportional to the joystick displacement.
- 4- To stop the movement, return the joystick to neutral and release the enable pedal.

**-NOTA-**

The Up / Down movement of Arm 1 results in the extension / retraction of the lower telescope. The Up movement is performed in 2 phases. During the first phase, Arm 1 and the lower telescope extend at the same time until the telescope sensor is activated and Arm 1 has reached the maximum authorised angle. The lower telescope then extends to its maximum course. When lowering Arm 1, the movement is performed in reverse order (In movement of the telescope, then retraction of the lower telescope and Down movement for Arm 1).

If the Up / Down movement of Arm 1 is stopped before the end of one of the phases, then started again, the movement will resume where it stopped.

**! DANGER !**

ONLY RAISE THE PLATFORM IF THE MACHINE IS ON EVEN, FIRM, HORIZONTAL AND FLAT GROUND. IF THE TILT ALARM IS TRIGGERED, TAKE THE TELESCOPE BACK IN AND RETURN THE PLATFORM TO ITS LOW POSITION. DO NOT USE THE GROUND STATION CONTROLS IF PERSONNEL IS ON PLATFORM EXCEPT IN EMERGENCY CASES. REFER TO THE SAFETY INSTRUCTIONS IN SECTION 2. IN THIS MANUAL



## OPERATOR AND SAFETY MANUAL



### 4.5.3 TELESCOPES

- **From the ground control station**

- 1- Press and hold the enable button.
- 2- Tilt the upper telescope control lever to the left to extend the telescope. Tilt the upper telescope control lever to the right to retract the telescope.
- 3- To stop the movement, release the control lever or the enable button.

- **From the work platform fixed control station**

- 1- Select the engine speed required.
- 2- Activate the validation pedal.
- 3- Within 10 seconds, tilt the upper telescope control lever rearwards to extend the upper telescope or forwards to retract the telescope.
- 4- To stop the movement, return the lever to neutral and release the enable pedal.

**-NOTE-**

The In / Out movement of the lower telescope is dependent from the Up / Down movement of Arm 1. It cannot be controlled independently from the latter. Refer to section 4.5.2 ELEVATION.

### 4.5.4 PLATFORM LEVELLING

This control is used to adjust the platform's level when driving on a slope or during the transport of the machine.

- **From the ground control station**

- 1- Activate and hold down the enable button.
- 2- Tilt the levelling control lever upwards or downwards to correct the work platform's horizontal level in the corresponding direction.
- 3- To stop the movement, release the control lever or the validation button.



**DANGER**



WHEN THE PLATFORM IS RAISED, ONLY USE THIS CONTROL TO MAKE A SLIGHT LEVEL CORRECTION. INAPPROPRIATE USE OF THIS CONTROL MAY RESULT IN OBJECTS OR PERSONS ON THE WORK PLATFORM FALLING OFF.

- **From the work platform control station**

- 1- Activate the enable pedal.
- 2- Within 5 seconds, tilt the levelling control lever upwards or downwards to correct the work platform's horizontal level in the corresponding direction.
- 3- To stop the movement, release the control lever or the enable pedal.

**-NOTE-**

Prohibiting this function when the work platform is raised may be configured in the system.



## OPERATOR AND SAFETY MANUAL



### -NOTE-

If for whatever reason the platform is tilted beyond 8°, only the levelling movement in the less aggravating direction will be allowed. If the tilt gets worse and exceed 10° all the movements are disabled and the operator will have to be rescued.

### 4.5.5 STRUCTURE ORIENTATION

- **From the ground control station**

- 1- Depress and hold the enable button.
- 2- Tilt the orientation control lever upwards to turn the structure clockwise or downwards to turn the structure anticlockwise.
- 3- To stop the movement, release the control lever or the enable button.

- **From the work platform fixed control station**

- 1- Depress the enable pedal.
- 2- Within 10 seconds, tilt the orientation control joystick to the right or to the left to move the structure in the corresponding direction.  
The orientation movement speed is proportional to the joystick displacement.
- 3- To stop the movement, return the joystick to neutral and release the enable pedal.

### -NOTA-

The structure rotation is disabled if the outrigger ground contact indicator is not lit. Refer to Erreur! Source du renvoi introuvable. **OUTRIGGERS** for other limitations on the structure orientation.

### 4.5.6 R WORKPLATFORM ROTATION

- **From the ground control station**

- 1- Depress and hold the enable button. The enable button must be activated before a movement is controlled.
- 2- Tilt the rotation control lever upwards to turn the structure clockwise or downwards to turn the structure anticlockwise.
- 3- To stop the movement, release the control lever or the enable button.

- **From the work platform fixed control station**

- 1- Depress the enable pedal
- 2- Within 10 seconds, tilt the rotation control lever upwards or downwards to rotate the platform in the corresponding direction.
- 3- To stop the movement, release the control lever or the enable pedal.





#### 4.5.7 ACCESS TO THE WORK PLATFORM

When the machine is not on outriggers, the work platform can be accessed at a height under 0.6m when adjusting the platform level and jib 3 in such a way that the access height is low enough.

When the platform is accessed with the outriggers deployed and the machine stabilized (outrigger ground contact indicator lit), the operator can adjust the height of the work platform using the controls for arm 1 or arm 2 from the ground control station.

### DANGER

ACCESS TO THE WORK PLATFORM MUST BE AT A HEIGHT BELOW 0.6M. THIS HEIGHT CAN HOWEVER BE ADJUSTED TO A HIGHER LEVEL. THE COMPANY ATN DOES NOT RECOMMEND ACCESS WITH THE PLATFORM AT A HEIGHT ABOVE 0.6M AND DOES NOT ASSUME ANY LIABILITY SHOULD THE CASE ARISE.



## OPERATOR AND SAFETY MANUAL



### 4.6. PARKING – STORAGE

- Park the machine on horizontal ground in a well-protected and ventilated area.
- When in drive position, use the controls for Jib3 and platform levelling to be able to climb in the platform at a correct height (under 0.6m).
- Lower the platform. Return the structure to the middle (the Jib1 cylinder must be in the middle of the engine compartment).
- Place the control station selector to O position and remove the key to prevent any unauthorised use.
- Protect the control boxes as well as warning or instruction stickers with canvas.
- For long-term storage:
  - Disconnect and charge the battery. Refer to Section 07.5. BATTERY0
  - Chock the tracks.
- For storage, the machine's length can be reduced by folding back the work platform under the telescopic arm:
  - 1- Remove any material that might be on the work platform.
  - 2- From the ground control station, raise slightly the arm 2.
  - 3- Use the platform levelling control to fold back the platform under the arm, while making sure the platform does not hit the ground.

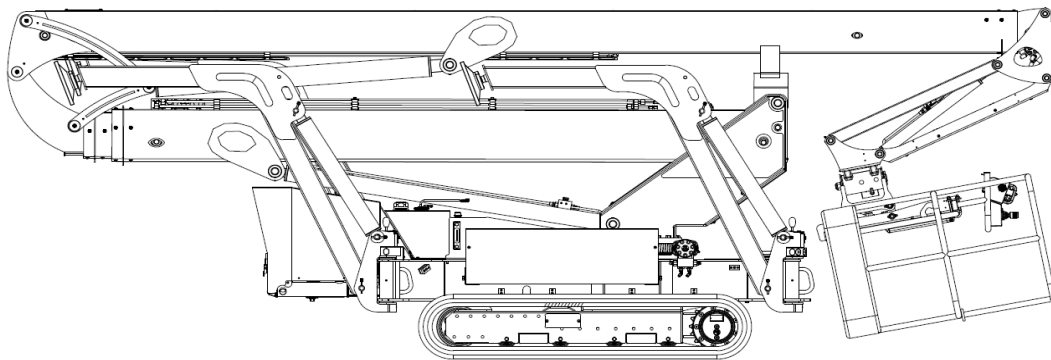
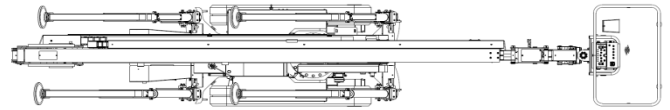
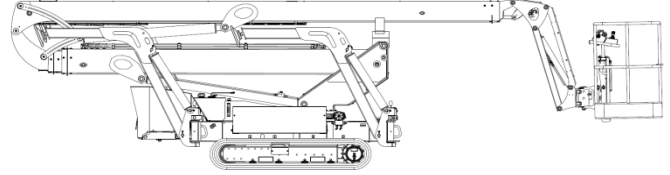



## 4.7. HANDLING – STOWAGE FOR TRANSPORT

### 4.7.1 HANDLING

The machine may be handled using a crane or similar equipment using the lifting/stowage rings on the chassis. You must then use adapted lifting accessories to avoid damaging the machine.

It can also be handled with forked machinery (ie. Forklift truck, telehandlers...). Insert the forks in the pockets in the chassis designed for this purpose. (cf. drawing below)



**DANGER**



CHECK THE CAPACITY OF THE LIFTING EQUIPMENT AND ACCESSORIES BEFORE RAISING THE MACHINE.

CHECK THAT THE OUTRIGGERS ARE PROPERLY LOCKED AND IN TRANSPORT POSITION.

WHEN HANDLING THE MACHINE, NO PERSONNEL OR MATERIAL MUST BE IN THE WORK PLATFORM..

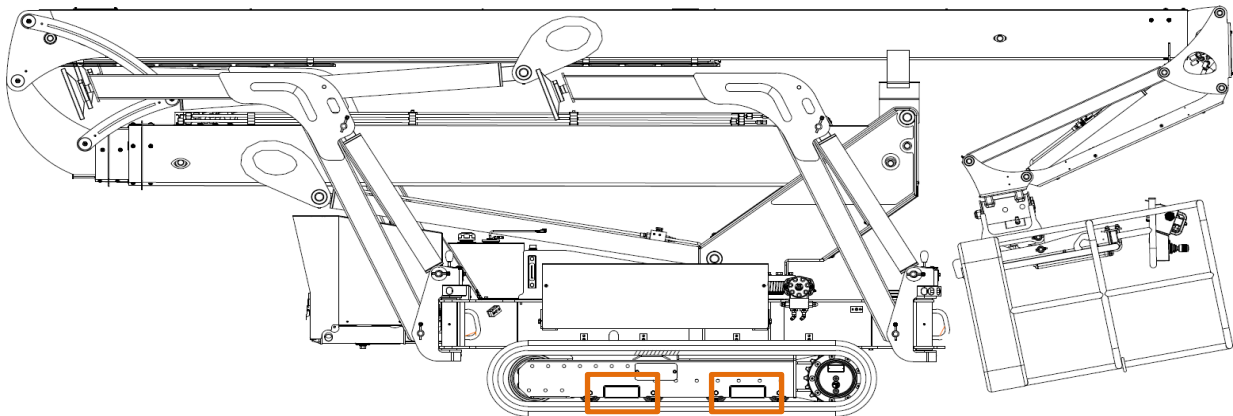

For this operation, the machine must be placed in parking-storage position as described in Section 4.6.



## OPERATOR AND SAFETY MANUAL



Use the outrigger hooks designed for this purpose to lift the machine as per the following drawing:

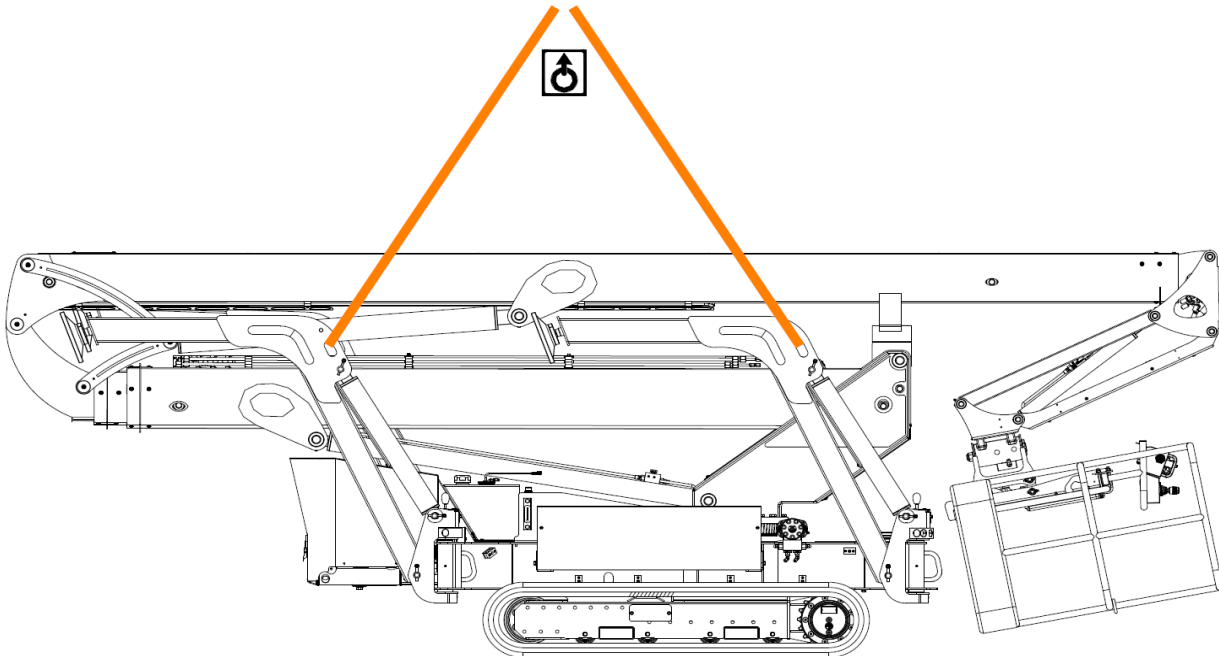

### 4.7.2 STOWAGE FOR TRANSPORT

During transport:

- The machine must be in transport position.
- The machine must be solidly secured to the vehicle platform as shown below. Use chains or slings rather than textile straps. In addition, the tracks may be chocked.
- The work platform must be tied to the ground.

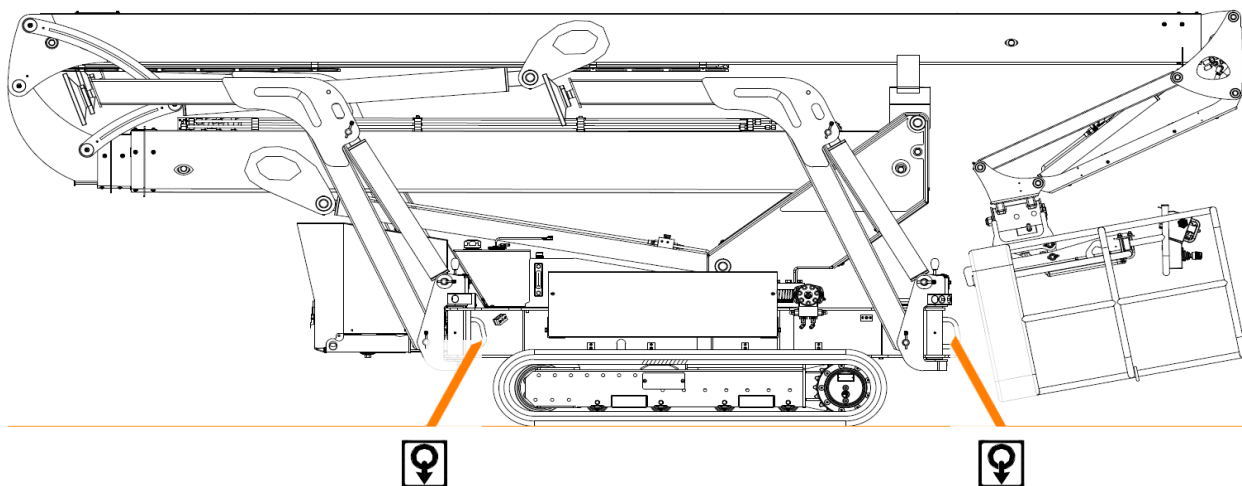



## 4.8. OUTRIGGERS

The machine is fitted with four outrigger cylinders to level the chassis before the work platform is raised.

The outriggers can only be controlled done when the platform is lowered.

### 4.8.1 *OUTRIGGER POSITIONS*

It is possible to place each outrigger in 3 different positions.

- Outrigger in normal position.
- Outrigger in folded in position

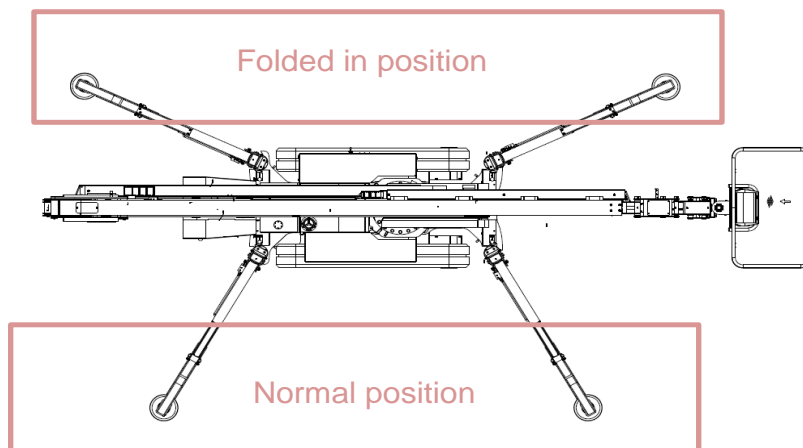

- Outrigger in transport / drive position  
In this position, the outriggers are flat against the structure.

These 3 positions can only be modified when the machine is fully lowered (arms and jib lowered, telescopes fully in and structure in line with the chassis).

Use the lever near the outrigger knuckle to modify their orientation (cf. photo opposite).

Push and hold the lever towards the inside of the machine to unlock the orientation of the outrigger. To lock the outrigger position, remove the lever from the notch and align the pin on the lever with the hole chosen in the outrigger knuckle.

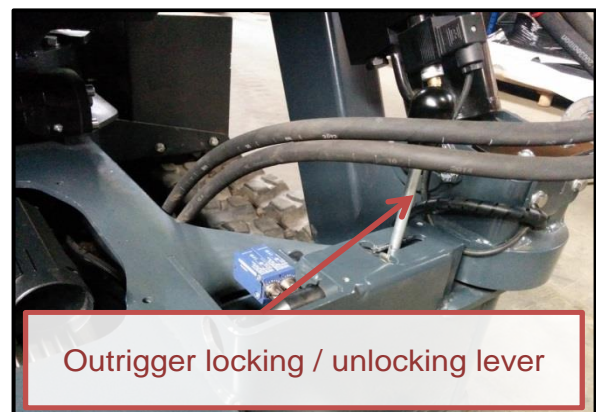

DO NOT PINCH OR CUT THE ELECTRIC CABLES DURING THE OUTRIGGER ROTATION.



WHEN OPERATING THE MACHINE ALWAYS ENSURE THE PIN FIXED ON THE LEVER IS NOT STUCK AND COINCIDES WITH ONE OF THE HOLES ON THE OUTRIGGER KNUCKLE, IN PARTICULAR WHEN DRIVING THE MACHINE.



## OPERATOR AND SAFETY MANUAL



### 4.8.2 OPERATION

- **Automatic levelling**

- 1- Select the platform control station and start one of the motors.
- 2- Depress the enable button on the mobile upper control station or the enable pedal in the work platform.
- 3- Within 10 seconds, depress and hold the automatic levelling control.
  - The engine speed increases until one of the outriggers contacts the ground.
  - Once this outrigger contacts the ground, the others come down with the engine at high speed.
- 4- Once all four outriggers contact the ground:
  - The engine speed slows down.
  - The levelling sequence starts.
- 5- Keep the control pushed forwards until :
  - The green indicator light for outrigger ground contact lights up steady.
  - The tilt indicator light switches off.
  - An acoustic signal sounds (4 rapid bips).

The outrigger movement stops automatically when the chassis is level.

- 6- To retract the outriggers, depress the enable button on the mobile upper control station and within 10 seconds pull the levelling control. When all four outriggers are retracted:
  - An acoustic signal (4 rapid beeps) sounds.

The outrigger movement stops automatically when they are fully retracted.

**-NOTA-**

**The green indicator light for ground control lights up when the tilt is in the  $\pm 0.2^\circ$  range on both centerlines and all the outrigger ground contacts are validated.**

The outrigger cylinders can be extended to their maximum course: Once phase 5 is completed, release the automatic levelling control, activate one outrigger manually and push again the automatic levelling control. The machine will be levelled again to a new stage.

**-NOTA-**

**The machine is more stable when near the ground. If the first stage is sufficient, it is recommended not to go to the next stabilization stage.**



## OPERATOR AND SAFETY MANUAL



- **Failure of the automatic levelling**

- 1- Loss of ground contact during the automatic levelling phase.

If one outrigger does not contact the ground firmly enough:

- The levelling sequence stops.
- An acoustic alarm (continuous sound) is triggered as long as the outrigger extension movement is controlled.
- In automatic mode, only the outrigger retraction is authorised.

- Check the condition and resistance of the ground or the absence of objects under the outrigger pads.

- If need be, move the machine on firmer grounds.

To retry the automatic levelling, all four outriggers must first be retracted until none contact the ground (system reset).

- 2- Outrigger cylinders at the end of their course or detection of tilt aggravation.

If the outriggers come to the end of their course before completion of the levelling sequence or if the chassis tilt aggravates instead of being corrected:

- The levelling sequence stops.
- An acoustic alarm (continuous sound) is triggered as long as the outrigger extension movement is controlled.

- Check the condition and resistance of the ground.

- In the event the chassis tilt increased, try to approximately level the machine manually and start again the automatic levelling cycle.

- If need be, move the machine on a surface where it will be possible to level the machine.

- **Manual levelling**

- 1- Select the platform control station and start one of the motors.

- 2- Depress the enable control (button or pedal) and within 10 seconds push the control forwards to extend the selected outrigger.

- 3- Control the appropriate outriggers until the tilt indicator light switches off and the ground control indicator lights up indicating the chassis is within an admissible inclination range.

- 4- To retract the outrigger, depress the enable control and within 10 seconds push the control rearwards to retract the selected outrigger.

Control the appropriate outriggers to keep the machine roughly level. When the outriggers are retracted:

- The outrigger position indicator light goes off.
- An acoustic signal (4 fast beeps) sounds.
- The outrigger movement stops automatically when they are fully retracted.

**- NOTE-**

**If the ground is too unstable or too soft to use the machine, it is recommended to use stabilization plates to reduce the surface pressure generated by the outriggers.**



OPERATOR AND SAFETY MANUAL



**DANGER**



THE OUTRIGGERS CAN BE LOWERED WITHOUT THE OPERATOR IN THE PLATFORM. IT IS ESSENTIAL TO ENSURE NOBODY (OPERATOR OR ELSE) IS UNDER THE OUTRIGGERS WHEN LOWERING THEM. ENSURE ALSO THAT NOTHING IS IN THE WAY OF THE OUTRIGGERS LIKE FOR EXAMPLE THE ELECTRIC CABLE OF THE ELECTRIC MOTOR.



**ATTENTION**



ENSURE THE GROUND IS FIRM ENOUGH TO SUPPORT THE OUTRIGGER PRESSURE. WHEN LOWERING THE OUTRIGGERS AND IN PARTICULAR WHEN CONTACTING THE GROUND, ENSURE THE OUTRIGGER PADS ARE IN PLACE PROPERLY.

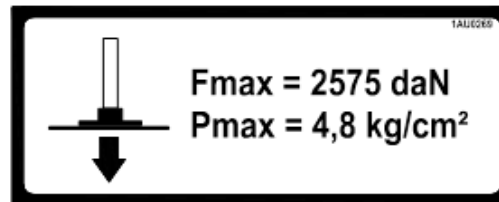

Most unfavourable configuration





## Section 5: SAFETY DEVICES

### 5.1 TILT SENSOR

The tilt sensor located in the ground control station compartment measures continuously the machine's tilt.

-

**-NOTE-**

**This device must not guide how the machine is used. Do not drive on inclines, uneven or loose surfaces.**

- When the structure is driven, the indicator lights up to indicate the machine is nearing the maximum admissible slope.
- When the structure is raised, the tilt light comes on and an alarm sounds when the maximum tilt authorised is reached. The alarm indicates that the machine has reached its stability limit.



**DANGER**



IF THE ALARM SOUNDS, STOP ALL OPERATIONS IMMEDIATELY. RETRACT THE TELESCOPE AND FULLY LOWER THE PLATFORM. LEVEL THE MACHINE AGAIN BEFORE RAISING THE WORK PLATFORM.



**DANGER**



NEVER PLACE ANY OBJECTS ON THE TILT SENSOR.

### 5.2 LOAD CONTROL

When the permissible load on the work platform is exceeded, the corresponding lights on the control stations flash, an alarm sounds and all the movements are stopped. The platform must be partially discharged until the alarm stops.

If the overload was triggered by a collision with an overhead obstacle, it is possible to clear the work platform with the following procedure. This clearance procedure is solely reserved for this precise case.

- 1- Turn the control station selector to ground controls.
- 2- Depress the enable button.
- 3- Within 10 seconds, control the desired movement (only telescopes in and arm lowering movements are allowed).
- 4- If within 10s the platform is not cleared, repeat the desired movement (always with validation and always within a 10s lapse of time).
- 5- Once it has been cleared, lower the platform. Check the good working condition of the platform and of the load control device before resuming operation.



**DANGER**



DO NOT ACTIVATE THE EMERGENCY STOP TO CUT THE ALARM AND CONTINUE WORKING. FIRST UNLOAD THE PLATFORM UNTIL THE ALARM STOPS.



### **5.3 SYSTEM FAULT**

The system fault light comes on when the control system detects an anomaly on one of the components or an operating fault.

Depending on the importance of the fault for the safe use of the machine, the system authorises the operation of certain command in degraded mode or completely disables the use of the machine.

The exact nature of the fault is indicated on the control module screen.

The machine's operation is re-established when the fault disappears or after the emergency stop is recycled (depending on the nature of the fault).

In all cases, the machine's use must be interrupted until the fault is corrected. After repair, a full check on the operation of the machine and the safety mechanisms must be carried out by a qualified person before the machine is returned into service.

If a fault occurs when the platform is raised and is occupied by personnel, appropriate measures must be taken to rescue the platform's occupants.

### **5.4 MOVEMENT ALARM**

A movement alarm may sound:

- During drive movements
- During structure movements
- During drive and structure movements

DANGER

DO NOT ACTIVATE THE EMERGENCY STOP TO CUT THE ALARM AND CONTINUE WORKING.  
IF POSSIBLE, LOWER THE PLATFORM BACK AND STOP USING THE MACHINE



## Section 6 : EMERGENCY PROCEDURES

### **6.1 EMERGENCY CONTROLS**

The emergency commands must only be used by personnel with detailed knowledge of the machine's operating characteristics and the ground control functions.

If the platform is jammed or stuck in a structure or equipment at height, stop operating the machine immediately. Use other equipment to rescue the platform's occupants. Stabilise the machine before you try to clear it. Make sure you do not control any movements that might lead to the machine tipping over.

#### **6.1.1 EMERGENCY STOP**

Each control station has an emergency stop button that stops the machine's movements and cuts the heat engine when it is pushed in.

#### **6.1.2 GROUND CONTROL STATION**

The priority control station on the ground is used to raise or lower the platform in the event of an emergency, when the operator on the work platform is unable to operate the machine.

- 1- Set the control station selector to "ground control station".
- 2- Start one of the motors.
- 3- Check that there are no obstacles at height that might interfere with the machine's movements.
- 4- Activate the appropriate controls to raise or lower the platform.

#### **6.1.3 DUAL ENERGY OPERATION**

In the event one of the two motors breaks down (electric or heat engine), the other will take over to return the platform to its low position.

Refer to section 4.2. HEAT ENGINE OPERATION and 4.3. ELECTRIC MOTOR OPERATION

### **6.2 AFTER AN INCIDENT**

After an incident, inspect the machine carefully and test the good working order of all controls and safeties. Only raise the platform by a metre if all the damages have been repaired and if all the controls are operating correctly. If in doubt, contact your reseller or the manufacturer.



## Section 7: MAINTENANCE FOR THE OPERATOR

This section is intended to provide the operator with the information to carry out verification and common maintenance operations on the machine. The following information does not replace the machine's preventive maintenance and inspection programme.

### 7.1 HEAT ENGINE

**- NOTE-**

Refer to the engine's maintenance manual for more information.

#### 7.1.1 CHARACTERISTICS

KUBOTA	Z602-E3B
Type	4-stroke diesel
Cooling	Liquid
Number of cylinders - Displacement	2 - 599 cm <sup>3</sup>
Low speed	2040 rev/mn
Max speed	3600 rev/mn
Oil content	2.5 Litres
Starter	12V - 1.0kW
Alternator	12V - 40A
Battery	12V - 50Ah / 400A
Power (ISO Continue) at max. speed	12.5kW (16.8ch)

#### 7.1.2 FUEL

Make sure that there is enough fuel in the tank to avoid discharging the circuit. Only use fuel for GNR type diesel engines. Refer to the engine's maintenance manual.



ONLY USE FUEL FOR GNR TYPE DIESEL ENGINES. MAKE SURE NO WATER OR IMPURITIES GET IN WHEN FILLING THE TANK.



USE OF SYNTHETIC OIL IS NOT RECOMMENDED.

#### 4.8.3 ENGINE OIL

At factory, the machine is delivered with Multi-Grade 15W40 lubricant. This type of lubricant enables the engine to start at temperatures as low as -15°C.

Depending on the operating conditions of the machine, you may need to adapt the type of lubricant (See graph opposite).

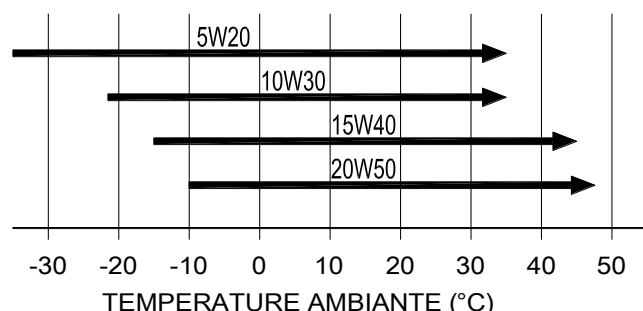



**OPERATOR AND SAFETY MANUAL**



**7.2 LUBRIFICATION**

**7.2.1 LUBRICANT SPECIFICATIONS - CAPACITIES**

CODE	DESCRIPTION	CAPACITE	NOTES
GR	Multi-Use grease	-	Adhesive grease, water and extreme pressure resistant
HM	Engine oil (15W40)	2.5 l	Refer to Section 7.1.3 ENGINE OIL
H46	Hydraulic oil H46	60 l	Fluid for hydraulic circuits Kinematic viscosity 46mm <sup>2</sup> /s @ 40°C
D	Fuel for Diesel engine	25 l	GNR Type (Non Road Diesel)
HR	Motor reducer oil	1 L	Gear box oil 80W90 (2x0.5L)

**7.2.2 LUBRICATION AND MAINTENANCE POINTS**

**-NOTE-**

Lubrication and maintenance intervals must be reduced if the machine is used intensively or in a dusty environment.

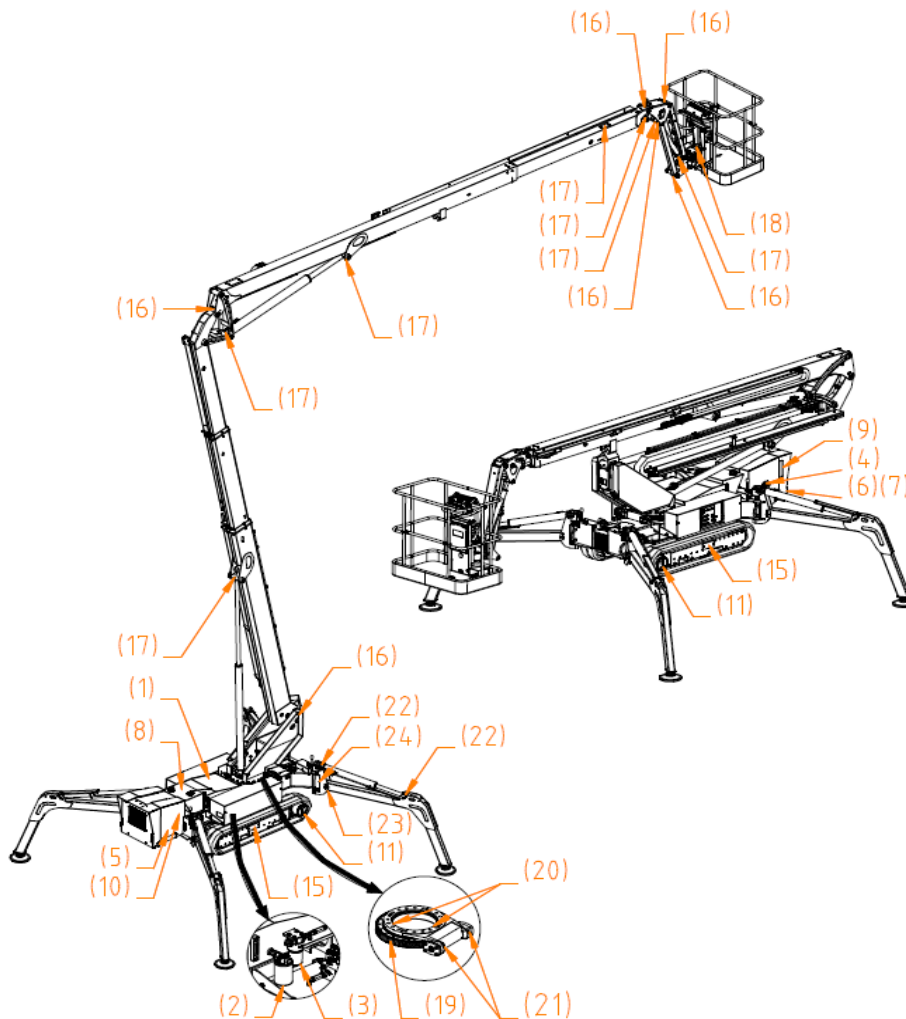



**OPERATOR AND SAFETY MANUAL**



REP	DESCRIPTION	NB. PTS	CODE LUB.	OPERATION	INTERVALS	
					1ST OPERATION	
1	Hydraulic tank	1	H46	Level check <sup>(5)</sup>		1
				Oil Change		
2	Hydraulic filter (Return)	1	-	Filter element replacement	50h	2
3	Hydraulic filter (Pressure filter on gear pump outlet)	1	-	Filter element replacement	50h	3
4	Motor oil	1	HM	Level check		4
				Oil change	50h	
5	Engine oil filter	1	-	Replacement	50h	5
6	Fuel filter	1	-	Filter element replacement	50h	6
7	Fuel pre-filter	1	-	Replacement		7
8	Fuel tank	1	-	Drainage and sediment cleaning		8
9	Cooling liquid	1	-	Level check		9
10	Air filter	1	-	Cleaning		10
				Filter element replacement		
11	Motor reducers	2	HR	Level check		11
				Oil change	50h	
				Level check		
15	Grease nipple – Track tensioners	2	GR	Application : Grease Pump		15
16	Grease nipples – Arm pins	6	GR	Application : Grease Pump		16
17	Grease nipples – Lift cylinders	8	GR	Application : Grease Pump		17
18	Grease nipples Load control system	4	GR	Application : Grease Pump		18
19	Turntable bearing teeth	1	GR	Remove old grease Application : Brush		19
20	Turntable bearing grease nipples.	2	GR	Application : Grease Pump		20
21	Grease nipples turntable worm gear reducer	2	GR	Application : Grease Pump		21
22	Grease nipple – outrigger cylinders	8	GR	Application : Grease Pump		22
23	Grease nipples – Outrigger pins	4	GR	Application : Grease Pump		23
24	Grease nipples – Outrigger knuckle pins	4	GR	Application : Grease Pump		24

**Notes:**

- J : At the beginning of each day or after each operator change.
- (1) : After the first 50 hours of operation.
- (2) : At the interval indicated or every year.
- (3) : At the interval indicated or every 2 years.
- (4) : The air filter body has a clogging indicator. Clean the filter if the indicator turns red before the indicated interval.
- (5) : The oil level must appear in the level indicator window.
- (6) : Turn the structure to distribute the grease.



### 7.3. TRACKS

Check the good general condition of the track, absence of cuts or foreign bodies imbedded in the rubber.

**- NOTE -**

**Certain cuts, in particular those located between both rows of lugs are normal.**

- **Track tension control**

- Safely lift the machine and place stable supports under the chassis.
- At the level of the central roller of the undercarriage, measure the distance **A** from the bottom of the roller to the rigid inside of the rubber band. The dimension **A** must be between 10 and 15 mm.
- Once the tension has been checked, pull on the tracks towards the compartments (electric and hydraulic) to ensure the track does not contact these compartments.



- **Settings:**

- 1- Remove each cover from both tensioning systems.
- 2- Remove the pin from the tensioning screw.
- 3- Tighten to tensioning screw to obtain 10 to 15 mm the dimension **A**.

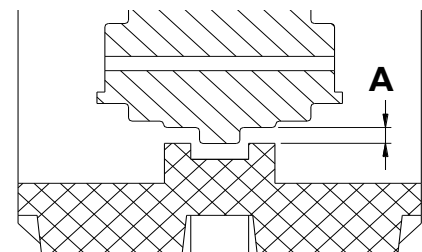

for

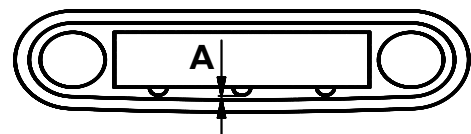

- **De-tracking /Re-tracking:**

If the machine de-tracked, re-install the track using the following procedure

- 1- Loosen the track using the tensioner grease nipple. Loosen the grease nipple slowly to prevent the grease from coming out too quickly.
- 2- Once the track is loose, fit the track on the sprocket teeth.
- 3- Fit the other end of the track on the tensioner.
- 4- Once the track is aligned in its undercarriage, tighten the grease nipple.
- 5- Tension the track until the max. optimal tension has been reached.



**TRACKS ARE HEAVY. DE-TRACKING / RE-TRACKING OPERATIONS REQUIRE AT LEAST 2 PERSONS OR A TRUCK.**



## 7.4. MOTOR REDUCERS

**- - NOTE -**

The oil in the motor reducers is not the same as the oil in the general hydraulic circuit.

- **DRAINAGE**

- 1- Position the motor as indicated on the drawing «**drainage position**». The cap Rep (a) is the level cap. The cap Rep (b) is either the drainage cap or the filling cap depending on the position of the motor.
- 2- Place a container under the motor reducer to recuperate the used oil.
- 3- Remove the cap Rep (b) to drain the oil: you can unscrew the cap Rep (a) to make the drainage easier.

**- NOTE -**

The first oil change must be done after the first 50 hours of operation, and every 400 hours thereafter.

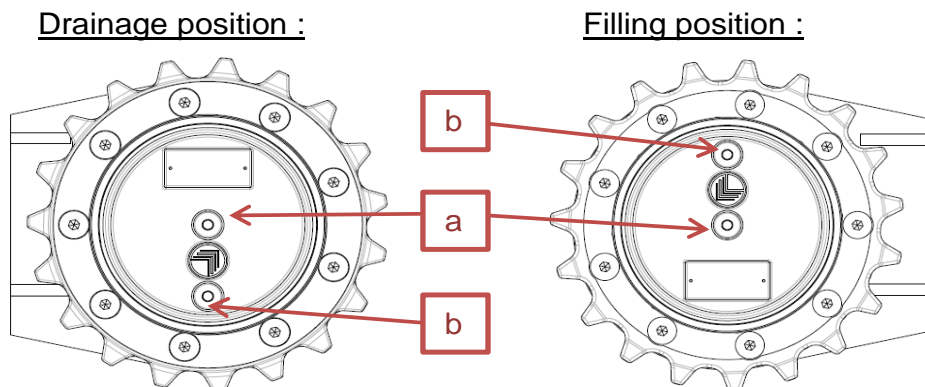

- **FILLING**

- 1- Position the motor as

indicated on the drawing «filling position».

- 2- Fill the motor reducer by the opening Rep (b) until the oil overflows from the opening Rep (a) (Refer to section «Lubrication» for the type of oil used).
- 3- Let the oil surplus drain for a few seconds.
- 4- Tighten the level cap Rep (a) then the cap Rep (b).

**- NOTE -**

The oil level in the motor reducers must be checked every 100 hours.





## 7.5. BATTERY



### DANGER



THE ELECTROLYTE CONTAINED IN THE BATTERIES IS HIGHLY CORROSIVE. AVOID ALL CONTACT WITH CLOTHING, SKIN OR EYES. IN THE EVENT OF CONTACT, RINSE THE AFFECTED AREA IMMEDIATELY WITH CLEAN WATER.

To ensure that the diesel engine starts up under all circumstances, the battery must be maintained in perfect charge condition.

- Remove all traces of salt that may form on the battery terminals.
- Check the level of electrolyte in the battery cells.
- If the electrolyte overflows, rinse the affected metal surfaces immediately in clean water.
- Check the charge state regularly by measuring the electrolyte density.

- **Charging the battery**

- Use a 12 Volt charger adapted to the battery's capacity.
- Disconnect the battery from the machine before charging it.
- To preserve the battery's lifetime, avoid quick recharges.
- Only charge the battery in well-ventilated premises.

- **Disconnecting - Connecting the battery**

To prevent any risk of short circuit :

- 1- Disconnect the Negative terminal (-) before the Positive terminal (+)
- 2- Reconnect the Positive terminal (+) before the Negative terminal (-)

- **Extended storage**

- If the machine needs to be stored for long periods, it is best to remove the battery and store it in dry premises away from frost.
- Charge the battery if the battery voltage in open circuit is under 12.40 volts.
- Check the electrolyte level and recharge the battery approximately every two months.



### CAUTION



Never add pure acid. Use distilled or demineralised water.



### CAUTION



BEFORE CHARGING THE BATTERY, CUT THE POWER TO THE MACHINE OR DISCONNECT THE BATTERY

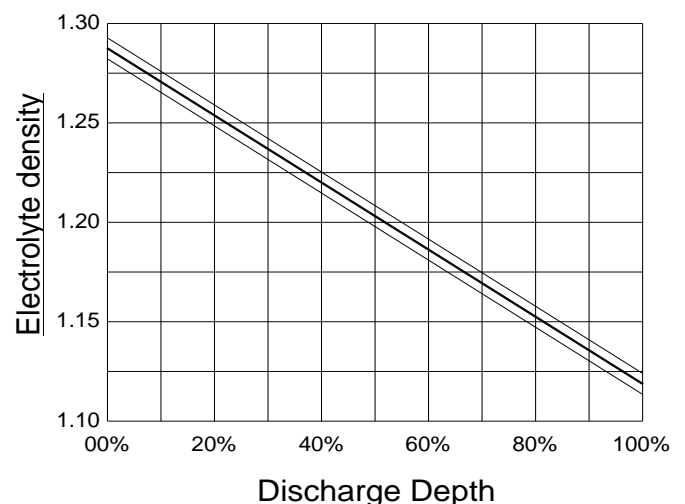



## Section 8. SCHEMAS



# OPERATOR AND SAFETY MANUAL



## 8.1. ELECTRICAL SCHEMATIC

### 1EL0031-07

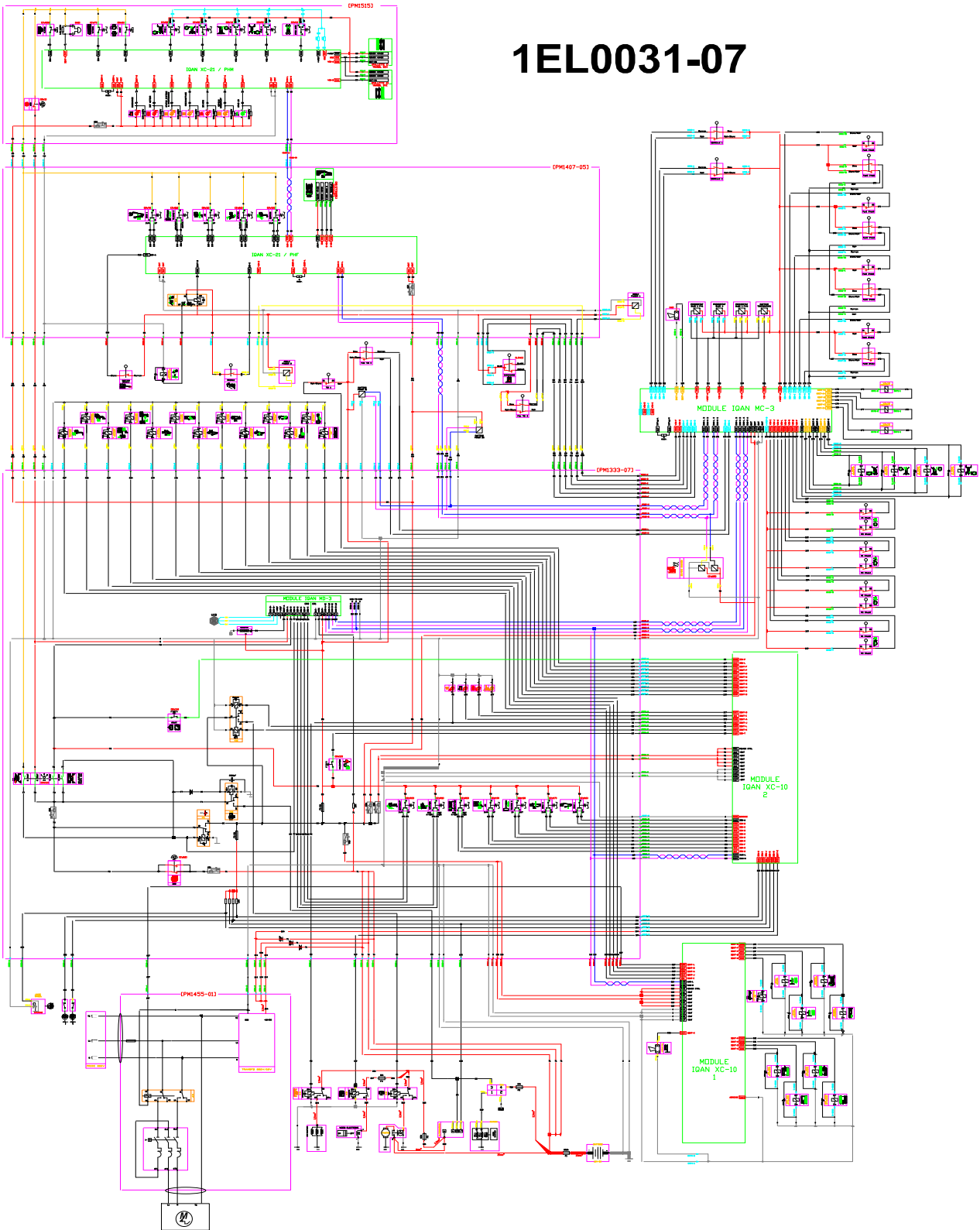



OPERATOR AND SAFETY MANUAL



8.2. HYDRAULIC SCHEMATIC

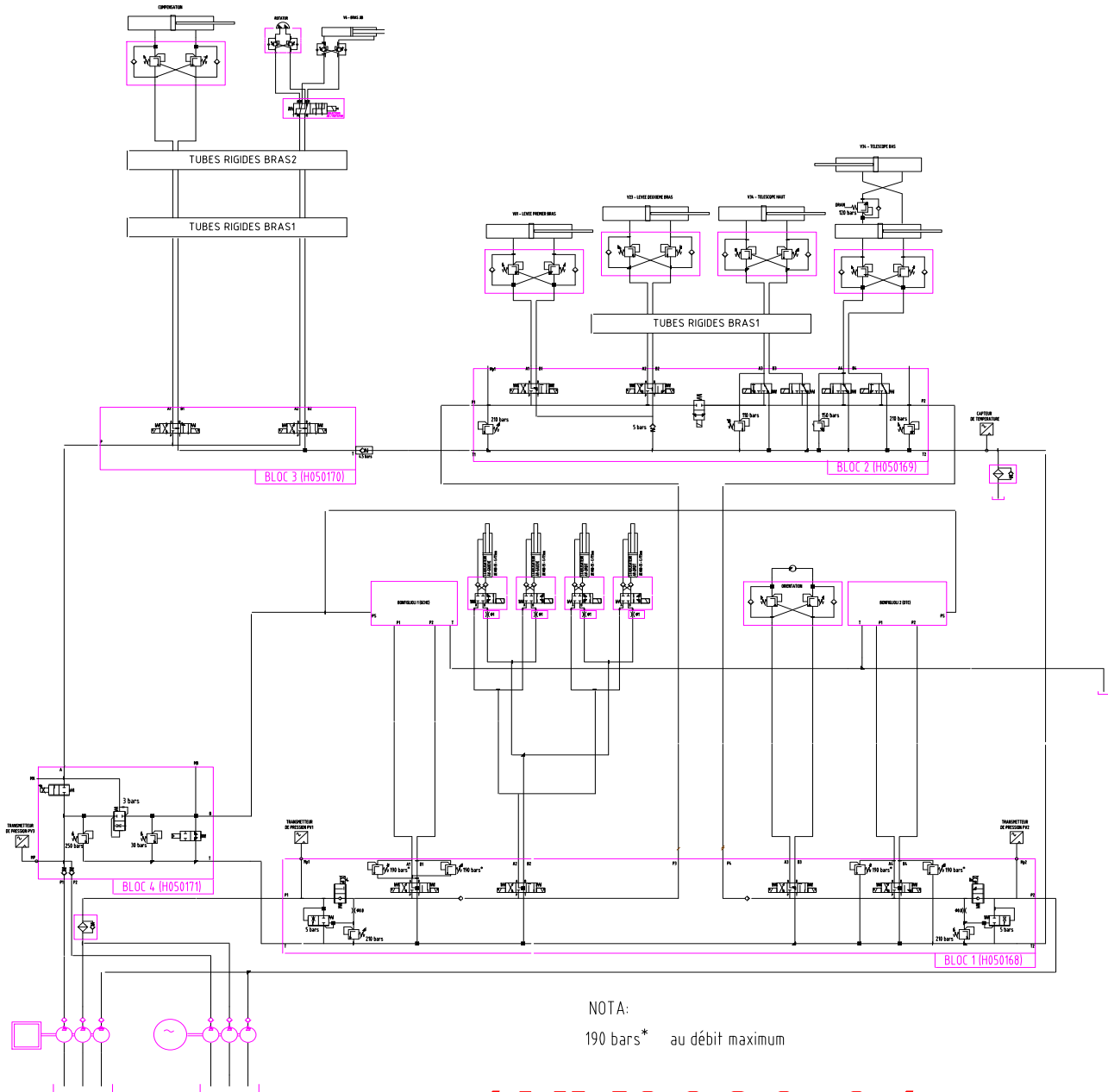

**1HY0030-01**



NOTES



OPERATOR AND SAFETY MANUAL



NOTES