

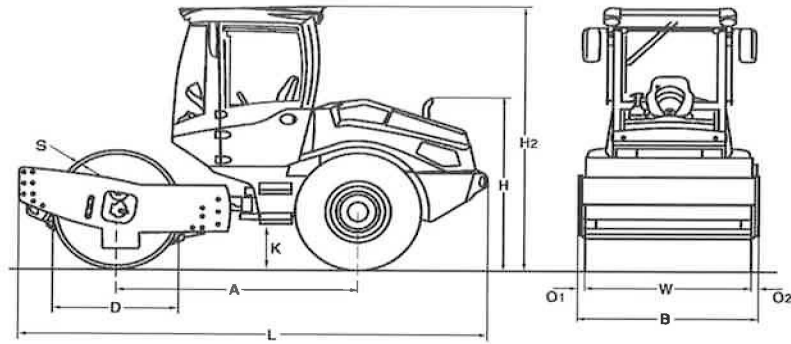

# TECHNICAL DATA

SINGLE DRUM ROLLERS  
BW 177 D-5





**Dimensions in mm**

	<b>A</b>	<b>B</b>	<b>D</b>	<b>H</b>	<b>H2</b>	<b>K</b>	<b>L</b>	<b>O1</b>	<b>O2</b>	<b>S</b>	<b>W</b>
<b>BW 177 D-5</b>	2350	1820	1230	1750	2800	380	4550	65	65	20	1690

Machine type	Compaction output (m3/h)			
	Rock fill	Gravel, sand	Mixed soil	Silt, clay
BW 177 D-5	-	210-420	160-320	70-140

Machine type	Compacted layer thickness (m)			
	Rock fill	Gravel, sand	Mixed soil	Silt, clay
BW 177 D-5	-	0,45	0,35	0,15



**Technical Data**

**BOMAG  
BW 177 D-5**

**Weights**

Grossweight .....	kg	7.800
Operating weight CECE w. ROPS-cabin .....	kg	6.600
Axle load, drum CECE .....	kg	4.000
Axle load, wheels CECE .....	kg	2.600
Static linear load CECE .....	kg/cm	23,7

**Dimensions**

Working width .....	mm	1.690
Track radius, inner .....	mm	2.975

**Driving Characteristics**

Speed (1) .....	km/h	0- 4,5
Speed (2) .....	km/h	0- 5,5
Speed (3) .....	km/h	0- 7,5
Speed (4) .....	km/h	0- 10,5
Max. gradeability without/with vibr. ....	%	49/46

**Drive**

Engine manufacturer .....		Kubota
Type .....		V3307 CR-T
Emission stage .....		Stage V / TIER4f
Exhaust gas aftertreatment .....		DOC+DPF
Cooling .....		water
Number of cylinders .....		4
Performance ISO 3046 .....	kW	55,4
Performance SAE J 1995 .....	hp	75,0
Speed .....	min-1	2.400
Fuel .....		Diesel
Electric equipment .....	V	12
Drive system .....		hydrost.
Drum driven .....		standard

**Drums and Tyres**

Tyre size .....	14.9-24/8PR
-----------------	-------------

**Brakes**

Service brake .....	hydrost.
Parking brake .....	hydromec.

**Steering**

Steering system .....	oscil.artic.	
Steering method .....	hydrost.	
Steering / oscillating angle +/- .....	grad	35/12

**Exciter system**

Drive system .....		hydrost.
Frequency (1) .....	Hz	29
Frequency (2) .....	Hz	32
Amplitude .....	mm	1,90/0,80
Centrifugal force .....	kN	112/74
Centrifugal force .....	t	11,4/7,5

**Capacities**

Fuel .....	l	110,0
------------	---	-------

Technical modifications reserved. Machines may be shown with options.



### Standard Equipment

- BOMAG ECOMODE
- Double pump system for travel drive (DH/PDH)
- No-Spin differential lock
- Rear axle with twin spring accumulator brakes
- Hydrostatic travel and vibration drive
- Hydrostatic articulated steering
- Articulated joint lock
- Warning, information and operation displays
- Single lever control for travel and vibration
- Emergency STOP
- Warning horn
- Back-up warning system
- Noise insulation
- 2 Contact scrapers Plastic (D/DH)
- 2 Scrapers (PDH)
- Tractor tires (PDH)



PRE 586 03 010

210119 Sa04

**BOMAG**  
Hellerwald  
D-56154 Boppard  
P.O. Box 5162  
Tel. (0)6742 - 1000  
Fax (0)6742 - 3090

