



# Bobcat®

## COMPACT EXCAVATOR E17



**EXPERIENCE**  
SMOOTH POWER & OPTIMUM COMFORT

***One Tough Animal™***



# E17 — SPECIFICATIONS

## E17

### WEIGHTS

Operating weight with canopy	1711 kg
Operating weight with cab	1807 kg
Additional weight for internal counterweight	-
Ground pressure	29.4 kPa

### ENGINE

Make / model	Kubota / D722-E2B-BCZ-7
Fuel/Cooling	Diesel/Liquid
Number of cylinders	3
Displacement	0.7 L
Maximum NET power (ISO 9249)	9.9 kW
Maximum NET torque (ISO 9249)	42.3 Nm

### PERFORMANCE

Digging force, standard dipperstick (ISO 6015)	9108 N
Digging force, long dipperstick (ISO 6015)	-
Digging force, bucket (ISO 6015)	16177 N
Drawbar pull	14334 N
Travel speed, low range	2.0 km/h
Travel speed, high range	3.2 km/h

### HYDRAULIC SYSTEM

Pump type	Triple gear pump
Pump capacity	32.5 L/min
Pump 1 capacity at 2500 RPM	10.0 L/min
Pump 2 and 3 capacity at 2500 RPM	11.3 L/min
Auxiliary flow	32.5 L/min
Auxiliary relief	227.0 bar

### SLEW SYSTEM

Boom swing, left	80 °
Boom swing, right	60 °
Slew rate	8.7 RPM

### FLUID CAPACITIES

Cooling system	3.3 L
Engine lubrication plus oil filter	3.3 L
Fuel reservoir	19.0 L
Hydraulic system	17.0 L

### ENVIRONMENTAL

Noise level LpA (EU Directive 2006/42/EC)	79 dB(A)
Noise level LWA (EU Directive 2000/14/EC)	93 dB(A)
Whole body vibration (ISO 2631-1)	0.74 ms <sup>-2</sup>
Hand-arm vibration (ISO 5349-1)	1.42 ms <sup>-2</sup>
Hand-arm vibration (ISO 5349-1) Uncertainty	0.37 ms <sup>-2</sup>

### STANDARD FEATURES

TOPS/ROPS/FOPS* canopy	Hydraulic and Travel Control Lockouts
Hydraulically retractable undercarriage from 1360 to 980 mm	Retractable seat belt
Exposed counterweight with 4 mm steel tailgate	Two-speed travel (E19)
980 mm dozer blade with two 190 mm blade extensions	Upperstructure four point tie down
230 mm rubber track	Engine with auto shutdown
Double acting auxiliary hydraulics	Full fuel warning alarm
Auxiliary quick couplers (E19)	Work light
Control console locks	Battery kill switch
Horn	Storage compartment
Hydraulic joystick controls	Cupholders
Foldable & ergonomic pedals	Warranty: 12 months or 2000 hours

\* (1) Tip Over Protective Structure (TOPS) – Meets requirements of ISO 12117. (2) Roll Over Protective Structure (ROPS) – Meets requirements of ISO 3471. (3) Falling Object Protective Structure (FOPS) – Meets requirements of ISO 3449.

### OPTIONS

TOPS/ROPS cab with heater	Keyless start
AM/FM MP3 stereo radio	Travel motion alarm
Cab/canopy light kit	Two-speed travel (E17)
Clamp ready long dipperstick (E19)	Deluxe textile suspension seat (Cab) (E17)
Long dozer blade	2nd Auxiliary hydraulics (E19)
Additional internal counterweight (E19)	Auxiliary hydraulic line on dipperstick
Comfort package (E19)	Auxiliary quick couplers (E17)
- Fingertip auxiliary and offset hydraulic control with selectable auxiliary hydraulic flow	Hydraulic clamp (E19)
- Auto Shift Drive Motors	Klac and Lehnhoff couplers
- Superior seat with high back (Canopy)	Boom Load Holding Valve
- Deluxe textile suspension seat (Cab)	Object handling certified

### WORKING RANGE

std./long dipperstick\* – std./long dozer blade\*\*

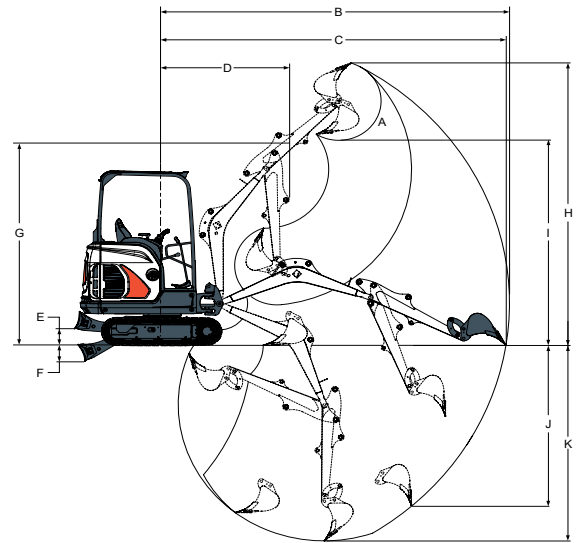

	E17
A	196 °
B	3919 mm
B*	-
C	3871 mm
C*	-
D	1526 mm
D*	-
E	220 mm
E**	300 mm
F	204 mm

	E17
F**	254 mm
G	2405 mm
H	3371 mm
H*	-
I	2370 mm
I*	-
J	1810 mm
J*	-
K	2249 mm
K*	-

### DIMENSIONS

std./long dipperstick\* – std./long dozer blade\*\*

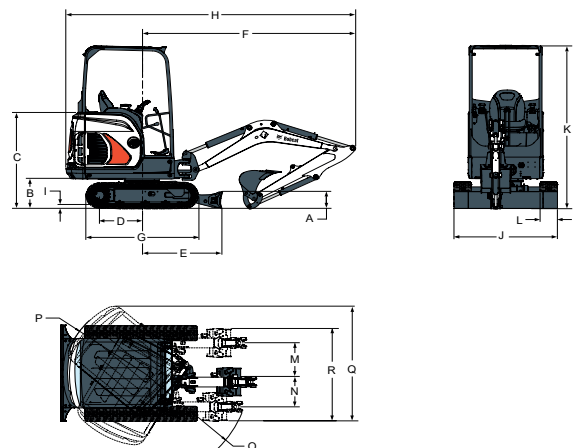

	E17
A	235 mm
B	419 mm
C	1340 mm
D	1114 mm
E	1045 mm
E**	1252 mm
F	2666 mm
F*	-
G	1476 mm
H	3665 mm
H*	-

	E17
I	25 mm
J	1360 mm > 980 mm
K	2299 mm
L	230 mm
M	433 mm
N	589 mm
O	1128 mm
P	1009 mm
Q	1801 mm
R	1645 mm