



**STRONG PARTNERS.
TOUGH TRUCKS.™**



HIGH CAPACITY FORKLIFT TRUCKS

H13-16XM-6

13 000 – 16 000 KG @ 600 MM





H13-16XM-6

DISTINGUISHING MARKS		HYSTER	
1.1	Manufacturer	H16XM-6	
1.2	Manufacturer's type designation	Diesel	
1.3	Drive: electric (battery or mains), diesel, petrol, fuel gas	Seated	
1.4	Operator type: hand, pedestrian, standing, seated, orderpicker	16.0	
1.5	Rated capacity / rated load	600	
1.6	Load centre distance	891	
1.8	Load distance, centre of drive axle to fork	3,300	
1.9	Wheelbase		
WEIGHTS		20,171	
2.1	Service weight ◊	33,649	
2.2	Axle loading, laden front / rear	10,420	
2.3	Axle loading, unladen front / rear	2,523	
TYRES & CHASSIS		L	
3.1	Tyres: L = pneumatic, V = solid, SE = pneumatic-shaped solid	12.00-20 20PR	
3.2	Tyre size, front	12.00-20 20PR	
3.3	Tyre size, rear	4x 2	
3.5	Wheels, number front / rear (x = driven wheels)	1,900	
3.6	Tread, front	2,000	
3.7	Tread, rear		
DIMENSIONS		15 12	
4.1	Tilt of mast/fork carriage forward/backward	α / β (°)	
4.2	Height, mast lowered †	h ₁ (mm)	
4.3	Free lift	h ₂ (mm)	
4.4	Lift †	h ₃ (mm)	
4.5	Height, mast extended	h ₄ (mm)	
4.7	Height of overhead guard ■	h ₅ (mm)	
4.7.1	Height of closed cabin without / with aircon	h ₆ (mm)	
4.7.2	Height of closed cabin with strobe light	h ₇ (mm)	
4.7.3	Height of closed cab with work lights	h ₈ (mm)	
4.7.4	Height of closed cab with aircon & strobe light	h ₉ (mm)	
4.8	Seat height relating to SIP ○	h ₁₀ (mm)	
4.12	Coupling height	h ₁₁ (mm)	
4.17	Overhang	l ₁ (mm)	
4.19	Overall length	l ₂ (mm)	
4.20	Length to face of forks	l ₃ (mm)	
4.21	Overall width across all	b ₁ (mm)	
4.22	Fork dimensions ISO 2331	s/o/l (mm)	
4.23	Fork carriage type	Apron pin (85 mm) type side shift	
4.24	Fork carriage width ●	b ₂ (mm)	
4.25	Distance over fork arms, minimum / maximum ✓	b ₃ (mm)	
4.30	Sideshift @ width over forks	b ₄ / b ₅ (mm)	
4.31	Ground clearance, laden, below mast	m ₁ (mm)	
4.32	Ground clearance, centre of wheelbase	m ₂ (mm)	
4.33.1	Load dimension b ₆ × l ₄ crossways	b ₆ × l ₄ (mm)	
4.34.1.1	Aisle width for pallets 1200 × 1200 crossways without operating clearance	A ₁ (mm)	
4.34.1.2	Aisle width for pallets 1200 × 1200 crossways with 200 mm operating clearance ◆	A ₂ (mm)	
4.34.1.3	Aisle width for pallets 1200 × 1200 crossways with 10% operating clearance	A ₃ (mm)	
4.33.2	Load dimension b ₇ × l ₅ crossways	b ₇ × l ₅ (mm)	
4.34.2.1	Aisle width for pallets 1200 × 800 crossways without operating clearance	A ₄ (mm)	
4.34.2.2	Aisle width for pallets 1200 × 800 crossways with 200 mm operating clearance ◆	A ₅ (mm)	
4.34.2.3	Aisle width for pallets 1200 × 800 crossways with 10% operating clearance	A ₆ (mm)	
4.35	Turning radius	W ₁ (mm)	
4.36	Internal turning radius ⊙	b ₈ (mm)	
PERFORMANCE DATA		25.6 28.1	
5.1	Travel speed, laden / unladen *	km/h	
5.2	Lift speed, laden / unladen	m/s	
5.3	Lowering speed, laden / unladen	m/s	
5.5	Drawbar pull, laden / unladen ☼	kN	
5.6	Maximum drawbar pull, laden / unladen	kN	
5.7	Gradeability, laden / unladen † ☼	%	
5.7	Gradeability, laden / unladen ◊	%	
5.9	Acceleration time, laden/unladen	s	
7.5		Fuel consumption according VDI cycle	
		l/h or kg/h	
ADDITIONAL DATA		19.5	
10.1	Working pressure for attachments	Mpa	
10.2	Oil volume for attachments	l/min	
10.3	Hydraulic oil tank, capacity	l	
10.4	Fuel tank, capacity	l	
10.4.1	DEF tank, capacity	l	
10.5	Steering design	Hydraulic power steering	
10.6	Number of steering rotation	3.7	
10.7	Sound pressure level at the driver's seat L _{PA2} * □	dB (A)	
10.7.1	Sound power level during the workcycle L _{WA2} * □	dB (A)	
10.8	Towing coupling, type DIN	108.5	
		Yes Pin	

NOTE:

Specifications are affected by the condition of the vehicle and how it is equipped, as well as the nature and condition of the operating area. Inform your dealer of the nature and condition of the intended operating area when purchasing your Hyster Truck.

◊ Weights are based on the following specifications: Complete truck with cab, pneumatic tyres, mast, carriage and forks.

† Unladen with new tyres

† Bottom of forks

■ +/- 3% tolerance depend on tyre inflated pressure / or tyre brand.

● Full suspension seat in depressed position.

● Add 50 mm with load backrest

✓ Optional equipment

◆ Stacking aisle width is based on the VDI standard calculation as shown on illustration. The British Industrial Truck Association recommends the addition of 100 mm to the total clearance (dimension a) for extra operating margin at the rear of truck.

⊙ Distance centre truck to centre of internal turning radius.

* Travel speed laden/unladen limited at 25 km/h as factory default.

† Gradeability figures are provided for comparison of tractive performance, but are not intended to endorse the operation of vehicle on the stated inclines. Follow instructions in the operating manual regarding operation on inclines.

☼ At 1.6 km/h

◊ At stall

* Measured according to the test cycles and based on the weighted values contained in EN12053.

□ Engine data based on low mount exhaust.

☎ Data available on request, as values are dependent on application.

NOTICE:

Care must be exercised when handling elevated loads. When the carriage and/or load is elevated, truck stability is reduced. It is important that the mast tilt in either direction is kept to a minimum when loads are elevated.

Operators must be trained and must read, understand and follow the instructions contained in the Operating Manual. All values are nominal values and they are subject to tolerances. For further information, please contact the manufacturer.

Hyster products are subject to change without notice.

Lift trucks illustrated may feature optional equipment. Values may vary with alternative configurations.

CE Safety:

This truck conforms to the current EU requirements.

Specification data is based on VDI 2198.

EQUIPMENT AND WEIGHT: Weights and axle loadings (lines 2.1, 2.2, 2.3) are based on the following specifications: H13-16XM-6: Complete truck with open operator compartment module, with 5336 mm BOF (5400 mm TOF) 2-stage NFL mast, 2500 mm wide Integral Sideshift carriage and 1370 mm long forks.

(Note: Truck weight with open operator module instead of fully equipped cab is 400 kg less. For axle loadings with fully equipped cab: Add 50 kg to the rear axle loadings and add 350 kg to the front axle loadings.)



MAST AND CAPACITY INFORMATION

H13-16XM-6 RATED CAPACITY KG@ 600 MM LOAD CENTRE

3 Stage FFL	Lift height $h_2 + s$ (mm)	Lowered height h_1 (mm)	Free lift height $h_2 + s$ (mm)	Extended height h_1 (mm)	With Sideshift (kg) H16XM-6
		5000	3270	1590	6680

RATED CAPACITIES

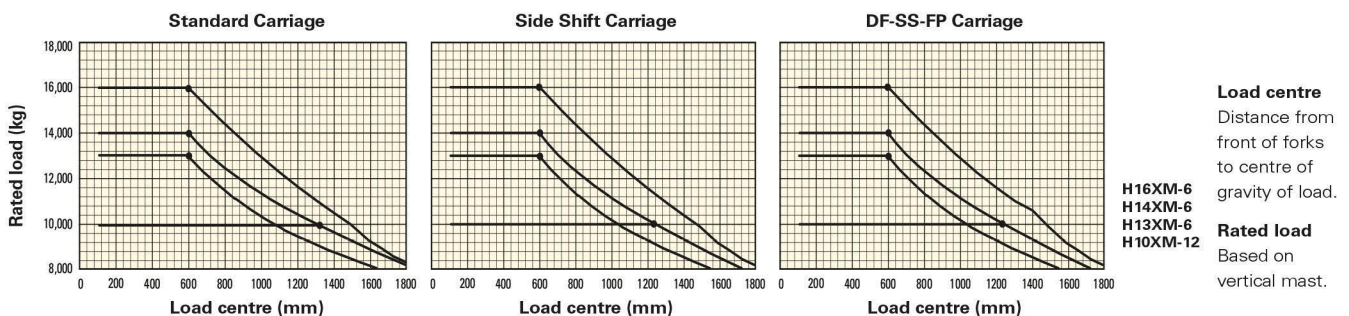

POWERTRAINS

DISTRIBUTION MANUFACTURER	1.1	Manufacturer (abbreviation)	HYSTER		
	1.2	Manufacturer's type designation	H13-16XM-6		
	1.3	Drive: electric (battery or mains), diesel, petrol, fuel gas	Diesel		
COMBUSTION-ENGINE	7.1	Engine manufacturer / type	Cummins	QSB 6.7	
	7.2	Engine power according to ISO 1585	122	2,300	
	7.2.1	Max. engine power according to ISO 1585	125	2,100	
	7.3	Rated speed	2,300		
	7.3.1	Torque at 1/min	732	1,500	
	7.4	Number of cylinders / displacement	6	6,700	
	7.8	Alternator	120		
	7.10	Battery voltage / nominal capacity	24	102	
	DRIVE TRAIN	8.1	Type of drive unit	Torque Converter	
		8.2	Transmission manufacturer / type	ZF	3 WG 161
8.6		Wheel drive / drive axle manufacturer / type	Axle Tech	PRC 785	
8.11		Service brake	Oil immersed disc		
8.12		Parking brake	Dry disc on drive axle		

TRUCK DIMENSIONS

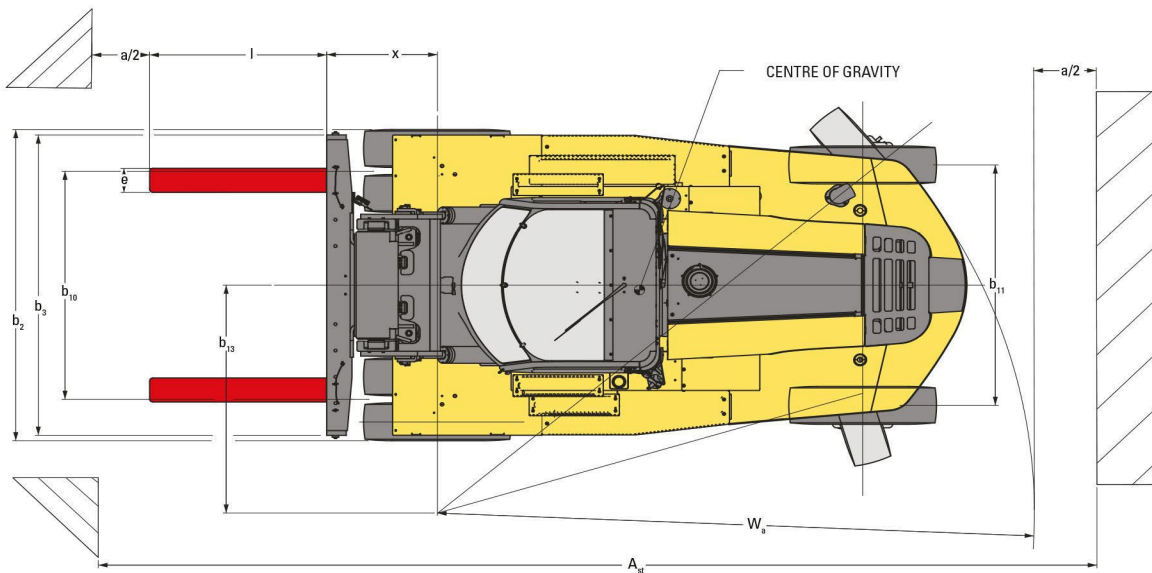
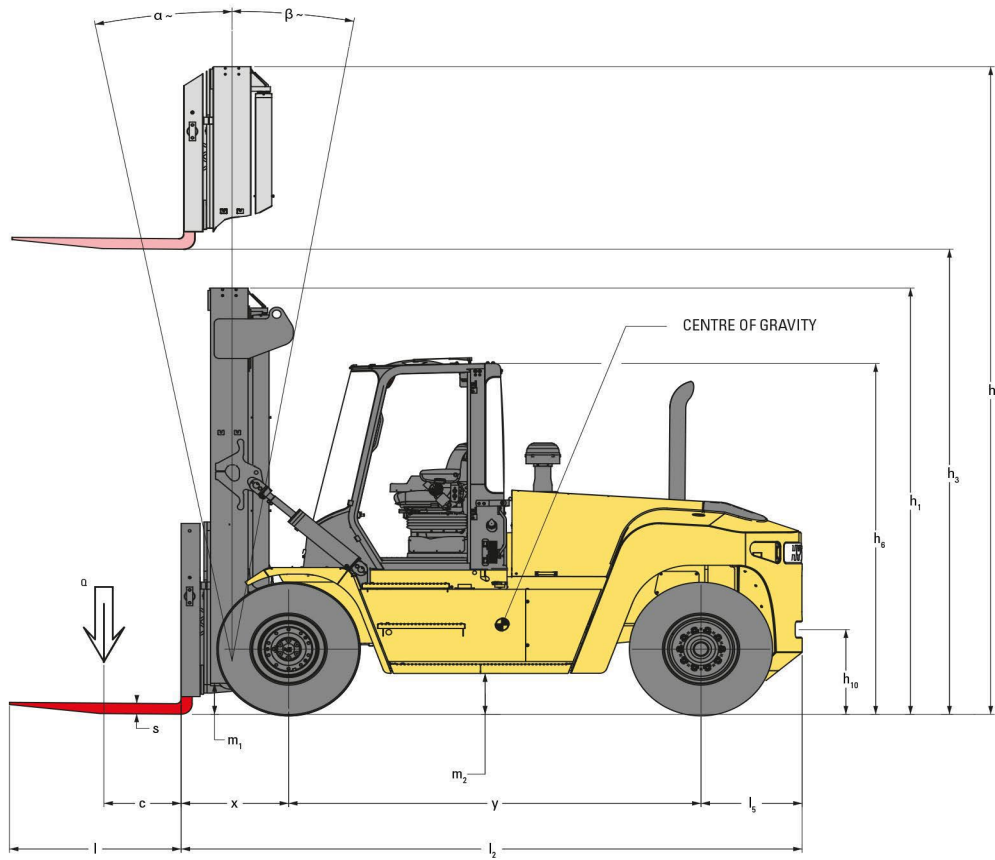

= Centre of gravity of unladen truck

$A_{ST} = W_a + x + l_6 + a$ (if $b_{12}/2 < b_{13}$)

$A_{ST} = W_a + (l_6 - x)^2 + (b_{12} - b_{13})^2 + a$ (if $b_{12}/2 > b_{13}$)

a = Minimum operating clearance
(VDI standard = 200 mm BITA recommendation = 300 mm)

l_6 = load lengths

b_{12} = load width