



HYDRAULIC EXCAVATOR

**OPERATOR'S
MANUAL**

Robex
210LC-9

HYUNDAI



CONTENTS

Foreword	0-1	6. Traveling of the machine	4-12
Before servicing this machine	0-2	7. Efficient working method	4-15
EC regulation approved	0-3	8. Operation in the special work sites	4-19
Table to enter S/No and distribution	0-4	9. Normal operation of excavator	4-21
Safety labels	0-5	10. Attachment lowering	4-22
Guide (direction, S/No, symbol)	0-16	11. Storage	4-23
SAFETY HINTS		12. RCV lever operating pattern	4-25
1. Before operating the machine	1-1	13. Switching hydraulic attachment circuit	4-27
2. During operating the machine	1-6	TRANSPORTATION	
3. During maintenance	1-13	1. Preparation for transportation	5-1
4. Parking	1-16	2. Dimension and weight	5-2
SPECIFICATIONS		3. Loading the machine	5-6
1. Major components	2-1	4. Fixing the machine	5-8
2. Specifications	2-2	5. Loading and unloading by crane	5-9
3. Working range	2-5	MAINTENANCE	
4. Weight	2-8	1. Instruction	6-1
5. Lifting capacities	2-11	2. Tightening torque	6-6
6. Bucket selection guide	2-18	3. Fuel, coolant and lubricants	6-9
7. Undercarriage	2-20	4. Maintenance check list	6-11
8. Specification for major components	2-22	5. Maintenance chart	6-16
9. Recommended oils	2-26	6. Service instruction	6-18
CONTROL DEVICES		7. Electrical system	6-40
1. Cab devices	3-1	8. Air conditioner and heater	6-43
2. Cluster	3-2	TROUBLESHOOTING GUIDE	
3. Switches	3-23	1. Engine	7-1
4. Levers and pedals	3-27	2. Electrical system	7-2
5. Air conditioner and heater	3-29	3. Others	7-3
6. Others	3-36	HYDRAULIC BREAKER AND QUICK CLAMP	
OPERATION		1. Selecting hydraulic breaker	8-1
1. Suggestion for new machine	4-1	2. Circuit configuration	8-2
2. Check before starting the engine	4-2	3. Maintenance	8-3
3. Starting and stop the engine	4-3	4. Precaution while operating the breaker	8-4
4. Mode selection system	4-6	5. Quick clamp	8-6
5. Operation of the working device	4-11	INDEX	
			9-1





FOREWORD

This manual contains a number of instructions and safety recommendations regarding driving, handling, lubrication, maintenance, inspection and adjustment of the excavator.

The manual is to promote safety maintenance and enhance machine performance.

Keep this manual handy and have all personnel read it periodically.

If you sell the machine, be sure to give this manual to the new owners.

This machine complies with EC directive "98/37/EEC".

1. Read and understand this manual before operating the machine.

This operator's manual may contain attachments and optional equipment that are not available in your area. Please consult your local Hyundai distributor for those items you require.

Improper operation and maintenance of this machine can be hazardous and could result in serious injury or death.

Some actions involved in operation and maintenance of the machine can cause a serious accident, if they are not done in a manner described in this manual.

The procedures and precautions given in this manual apply only to intended uses of the machine. If you use your machine for any unintended uses that are not specifically prohibited, you must be sure that it is safe for you and others. In no event should you or others engage in prohibited uses of actions as described in this manual.

2. Inspect the jobsite and follow the safety recommendations in the safety hints section before operating the machine.

3. Use genuine Hyundai spare parts for the replacement of parts.

We expressly point out that Hyundai will not accept any responsibility for defects resulting from non-genuine parts or non workmanlike repair.

In such cases Hyundai cannot assume liability for any damage.

Continuing improvements in the design of this machine can lead to changes in detail which may not be reflected in this manual. Consult Hyundai or your Hyundai distributor for the latest available information for your machine or for questions regarding information in this manual.



BEFORE SERVICING THIS MACHINE

It is the responsibility of the owner and all service and maintenance personnel to avoid accidents and serious injury by keeping this machine properly maintained.

It also is the responsibility of the owner and all service and maintenance personnel to avoid accidents and serious injury while servicing the machine.

No one should service or attempt to repair this machine without proper training and supervision.

All service and maintenance personnel should be thoroughly familiar with the procedures and precautions contained in this manual.

All personnel also must be aware of any federal, state, provincial or local laws or regulations covering the use and service of construction equipment.

The procedures in this manual do not supersede any requirements imposed by federal, state, provincial or local laws.

Hyundai can not anticipate every possible circumstance or environment in which this machine may be used and serviced.

All personnel must remain alert to potential hazards.

Work within your level of training and skill.

Ask your supervisor if you are uncertain about a particular task. Do not try to do too much too fast.

Use your common sense.



EC REGULATION APPROVED

- Noise level (EN474-1 ANNEX 5.13 and 2000/14/EC) are as followings.

LWA : 102dB (EU only)

LPA : 71dB

- The value of vibrations transmitted by the operator's seat are lower than standard value of (EN474-1 ANNEX 5.4.1.4 and 2002/44/EC)





TABLE TO ENTER SERIAL NO. AND DISTRIBUTOR

Machine Serial No.	
Engine Serial No.	
Manufacturing year	
Manufacturer Address	Hyundai Heavy Industries co., Ltd. 1, Jeonha-Dong, Dong-Ku, Ulsan 682-792, Korea
Distributor for U.S.A Address	Hyundai Heavy Industries U.S.A, Inc 955 Estes Avenue EIK Grove village IL, 60001 U.S.A
Distributor for Europe Address	Hyundai Heavy Industries Europe N. V. Vossendal 11 2240 Geel Belgium
Dealer Address	



SAFETY LABELS

1. LOCATION

Always keep these labels clean. If they are lost or damaged, attach them again or replace them with a new label.

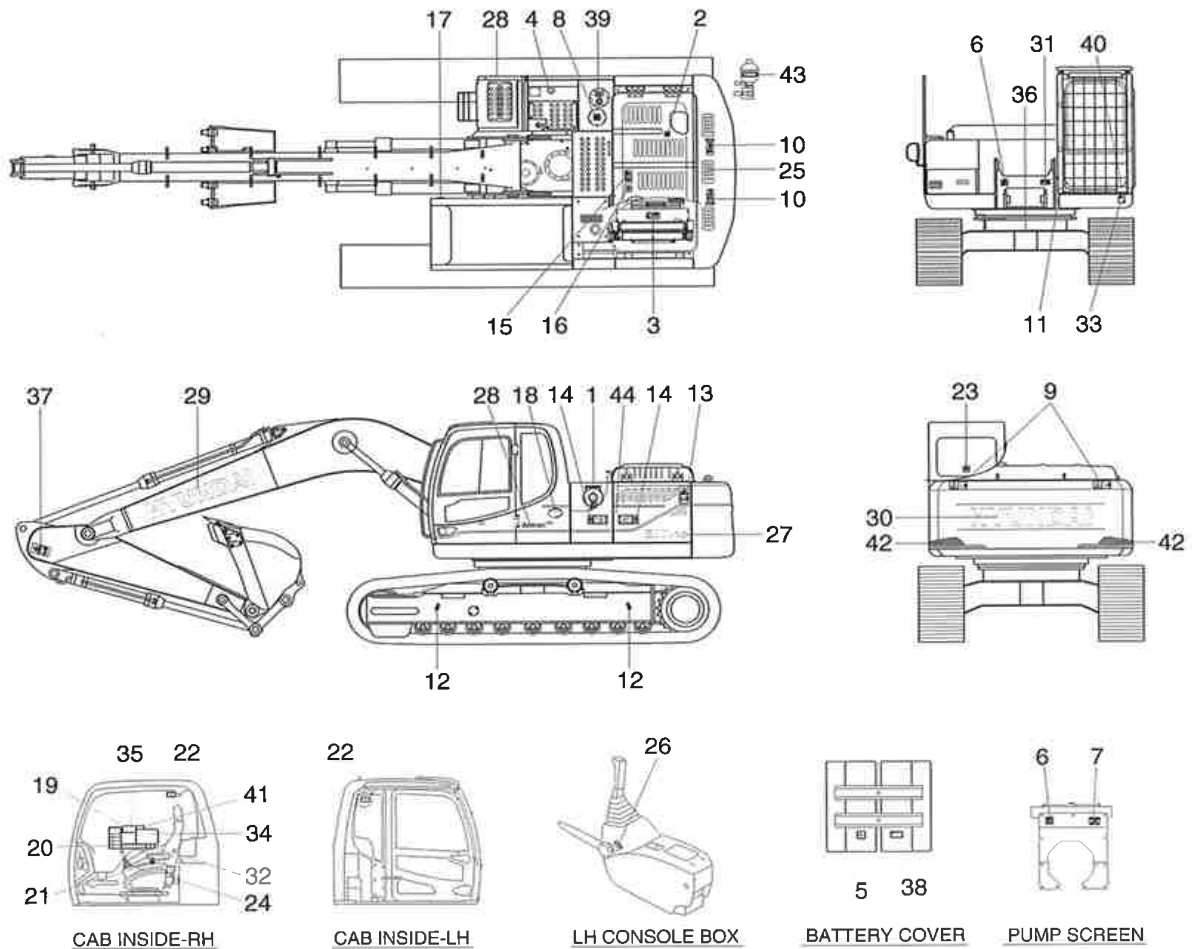

- | | | |
|-------------------------|--------------------------------------|--------------------------|
| 1 Air cleaner filter | 16 No step engine hood | 31 Reduction gear grease |
| 2 Turbocharger cover | 17 Transporting | 32 Locking-clamp |
| 3 Radiator cap | 18 Low emission engine | 33 Noise level LWA |
| 4 Fueling | 19 Control ideogram | 34 Service instruction |
| 5 Battery accident | 20 Ref operator manual-Cab RH pillar | 35 Lifting chart |
| 6 High pressure hose | 21 Hammer | 36 Tie |
| 7 Hydraulic oil level | 22 Safety front window | 37 Keep clear-Boom/arm |
| 8 Hydraulic oil lub | 23 Alternate exit | 38 ECU connector |
| 9 Keep clear-rear | 24 Air conditioner filter | 39 Falling |
| 10 Lifting eye | 25 Safety work | 40 FOPS FOG plate |
| 11 Name plate | 26 Safety lever | 41 Turbocharger |
| 12 Slinging ideogram | 27 Model name | 42 Reflecting |
| 13 Keep clear-side | 28 Logo (ROBEX) | 43 Accumulator |
| 14 Stay fix | 29 Trade mark (boom) | 44 Control ideogram |
| 15 Shearing-engine hood | 30 Trade mark (CWT) | |

21090SL01A



2. DESCRIPTION

There are several specific warning labels on this machine please become familiarized with all warning labels.

Replace any safety label that is damaged, or missing.

1) AIR CLEANER FILTER (item 1)

This warning label is positioned on the air cleaner cover.

- ※ Periodic and proper inspection, cleaning and change of elements prolong engine life time and maintain the good performance of engine.

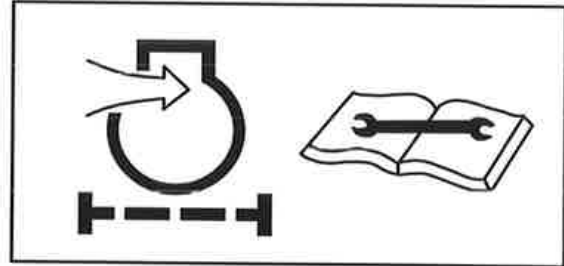

21070FW01

2) TURBOCHARGER COVER (item 2)

This warning label is positioned on the turbocharger cover.

- ⚠ Do not touch turbocharger or it may cause severe burn.



21070FW02

3) RADIATOR CAP (item 3)

This warning label is positioned on the radiator.

- ⚠ Never open the filler cap while engine running or at high coolant temperature.



14070FW03

4) FUELING (item 4)

This warning label is positioned on the right side of fuel filler neck.

- ⚠ Stop the engine when refueling. All lights or flames shall be kept at a safe distance while refueling.

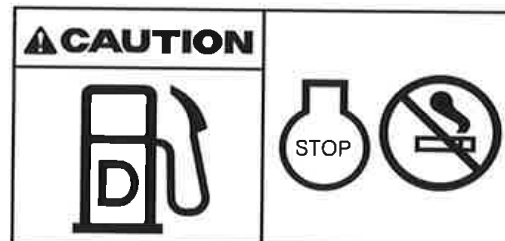

21070FW04

5) BATTERY ACCIDENT (item 5)

This warning label is positioned on the battery cover.

- ▲ Electrolyte containing sulfuric acid cause severe burns. Avoid being in contact with skin, eyes or clothes. In the event of accident flush with sufficient water, call a physician immediately.
- ※ Maintain the electrolyte at the recommended level. Add distilled water to the battery only when starting up, never when shutting down.
With electrolyte at proper level, less space may cause the gases to be accumulated in the battery.
- ▲ Extinguish all smoking materials and open flames before checking the battery.
- ▲ Do not use matches, lighters or torches as a light source near the battery for the probable presence of explosive gas.
- ▲ Do not allow unauthorized personnel to change the battery or to use booster cables.
- ▲ For safety from electric shock, do not battery terminal with a wet hand.

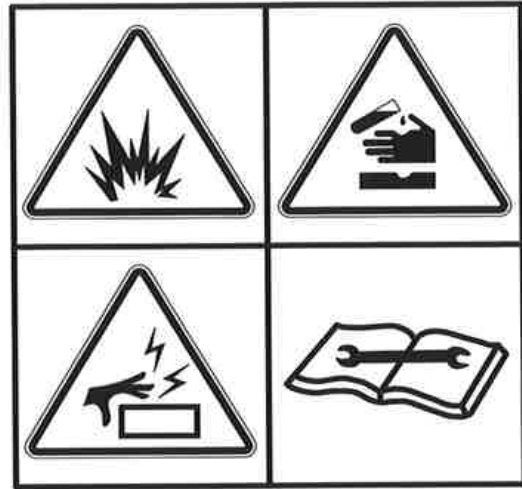

36070FW05

6) HIGH PRESSURE HOSE (item 6)

This warning label is positioned on the screen plate.

- ▲ Escaping fluid under pressure can penetrate the skin causing serious injury.
- ※ Study the service manual before service job.



14070FW29

7) HYDRAULIC OIL LEVEL (item 7)

This warning label is positioned on the screen plate.

- ▲ Place the bucket on the ground whenever servicing the hydraulic system.
- ※ Check oil level on the level gauge.
- ※ Refill the recommended hydraulic oil up to specified level if necessary.

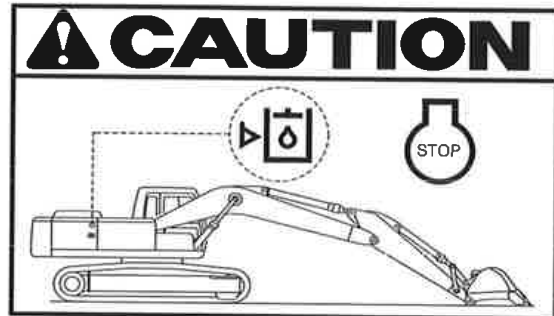

21070FW07

8) HYDRAULIC OIL LUBRICATION (item 8)

This warning label is positioned on the top of the hydraulic tank.

- ※ Do not mix with different brand oils.
- ▲ Never open the filler cap while high temperature.
- ▲ Loosen the cap slowly and release internal pressure completely.



14070FW08

9) KEEP CLEAR (item 9)

This warning label is positioned on the rear of counterweight.

- ▲ To prevent serious personal injury or death keep clear of machine swing radius.
- ▲ Do not deface or remove this label from the machine.

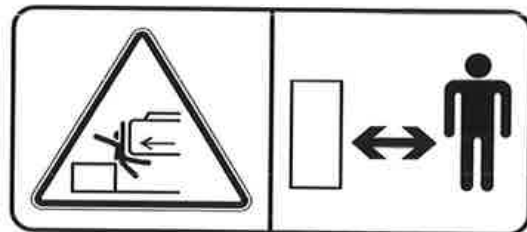

21090FW09

10) LIFTING EYE (item 10)

This warning label is positioned on the counterweight.

- ▲ Do not lift the machine by using lifting eyes on the counterweight or the lifting eyes may be subject to overload causing its breaking and possible personal injury.
- ※ See page 5-9 for proper lifting method of the machine.

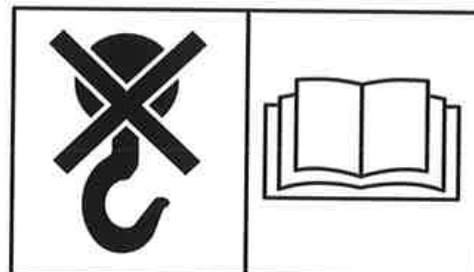

21070FW10



11) SIDE KEEP CLEAR (item 13)

This warning label is positioned on the side of LH rear side cover.

- ▲ To prevent serious personal injury or death keep clear of machine swing radius.
- ▲ Do not deface or remove this label from the machine.



21070FW13

12) STAY FIX (item 14)

This warning label is positioned on the side cover.

- ▲ Be sure to support the stay when the door needs to be opened.
- ▲ Be careful that the opened door may be closed by the external or natural force like strong wind.



21070FW14

13) SHEARING-ENGINE HOOD (item 15)

This warning label is positioned on the engine hood.

- ▲ Don't open the engine hood during the engine's running.
- ▲ Don't touch exhaust pipe or it may cause severe burn.

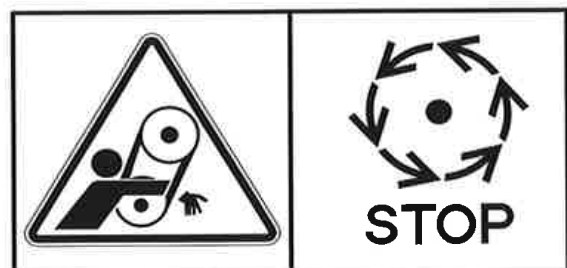

21070FW15



14) NO STEP-ENGINE HOOD (item 16)

This warning label is positioned on the engine hood.

△ Don't step on the engine hood.



21070FW16

15) TRANSPORTING (item 17)

This warning label is positioned right side of upper frame.

▲ Study the operator's manual before transporting the machine, if provided and tie down arm and track to the carrier with lashing wire.

See page 5-8 for details.



14070FW17

16) CONTROL IDEOGRAM (item 19)

This warning label is positioned in right window of the cab.

▲ Check the machine control pattern for conformance to pattern on this label. If not, change label to match pattern before operating machine.

▲ Failure to do so could result in injury or death.

See page 4-11 for details.

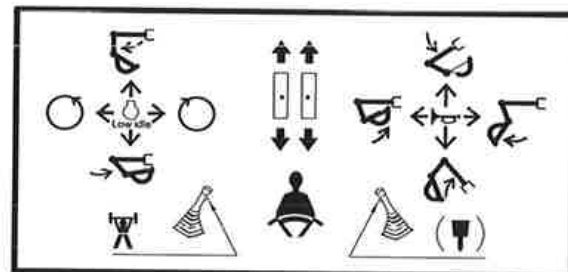

36070FW19

17) REF OPERATOR MANUAL (item 20)

This warning label is positioned on the right side window of the cab.

▲ Study the operator's manual before starting and operating machine.

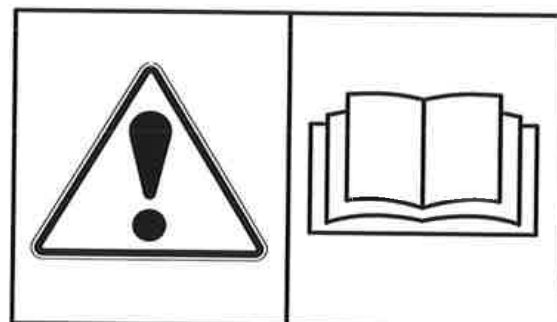

21070FW22

18) MAX HEIGHT (item 20)

This warning label is positioned on the right side window of the cab.

- ▲ **Serious injury or death can result from contact with electric lines.**

An electric shock being received by merely coming into the vicinity of an electric lines, the minimum distance should be kept considering the supply voltage as page 1-7.

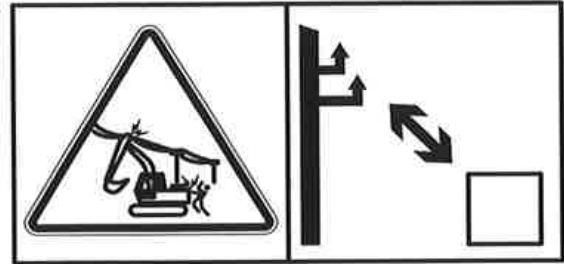

21070FW23

19) INTERFERENCE (item 20)

This warning label is positioned on the right side window of the cab.

- ▲ **Be careful to operate machine equipped with quick clamp or extensions.**
- ▲ **Bucket may hit cab or boom, boom cylinders when it reached vicinity of them.**

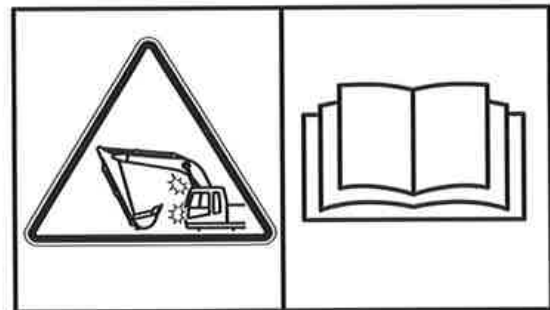

21090FW62

20) SAFETY FRONT WINDOW (item 22)

This warning label is positioned on the both side window of the cab.

- ▲ **Be careful that the front window may be promptly closed.**

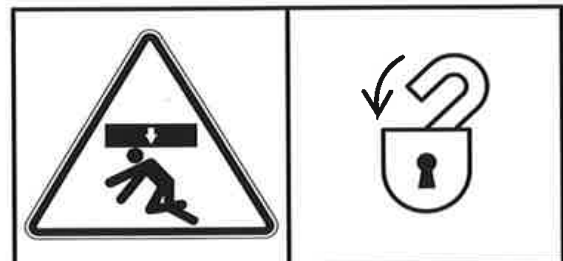

21070FW24

21) ALTERNATE EXIT (item 23)

This warning label is positioned on the inside of rear window.

- ※ **The rear window serves us an alternate exit.**
- ※ **To remove rear window, pull the ring and push out the glass.**



21070FW25

22) AIR CONDITIONER FILTER (item 24)

This warning label is positioned on the air conditioner cover.

- ※ Periodic and proper inspection, cleaning and change of filter prolong air conditioner life time and maintain good performance.

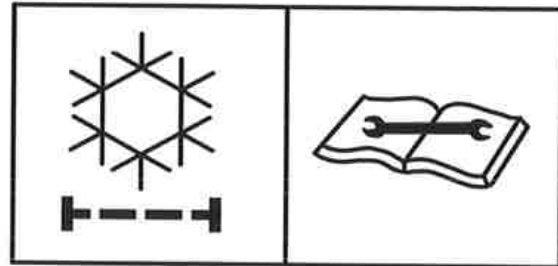

21070FW26

23) SAFETY LEVER (item 26)

This warning label is positioned on the cover of the safety lever.

- ⚠ Before you get off the machine be sure to place the safety lever LOCKED position.



30007A1FW07A

24) REDUCTION GEAR GREASE (item 31)

This warning label is positioned in the front of upper frame.

- ⚠ Grease is under high pressure. Grease coming out of the grease plug under pressure can penetrate the body causing injury or death.

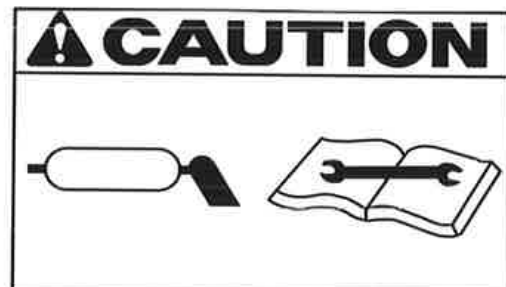

21070FW35

25) CLAMP-LOCKING (item 32)

This warning label is positioned on the right side window of cab.

- ⚠ Serious injury or death can result from dropping bucket.
- ⚠ Operating the machine with quick clamp switch unlocked or without safety pin of moving hook can cause the bucket to drop off.

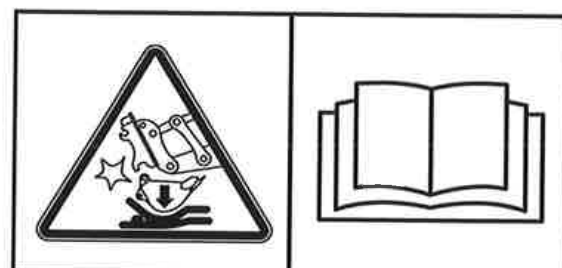

14070FW60



26) TIE (item 36)

This warning label is positioned on the lower frame.

- ▲ Make sure no personal are standing close to the tow rope.
- ▲ See page 4-14 for detail.

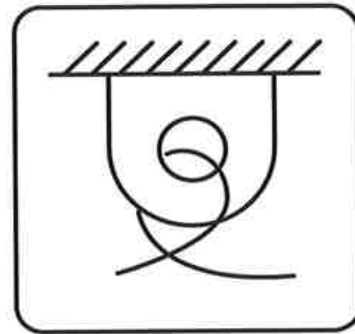

4507A0FW02

27) KEEP CLEAR-BOOM/ARM (item 37)

This warning label is positioned on both side of the arm.

- ▲ Serious injury or death can result from falling of the attachment.
- ▲ To prevent serious injury or death, keep clear the underneath of attachment.



14070FW31

28) ECU CONNECTOR (item 38)

This warning label is positioned on the battery cover.

- ▲ Before carrying out any electric welding on this machine, follow the below procedure.
 - Pull the connector out of all electric control units.
 - Connector the ground lead of the welding equipment as close to the welding point as possible.
- ※ See page 6-42 for detail.

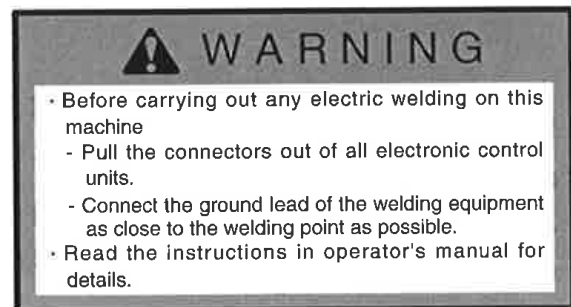

7807AFW20



29) FALLING (item 39)

This warning label is positioned on the top of the hydraulic tank.

- ▲ Falling is one of the major cause of personal injury.
- ▲ Be careful of slippery conditions on the platforms, steps and handrails when standing on the machine.



14070FW30

30) TURBOCHARGER (item 41)

This warning label is positioned on the right window of the cab.

- ▲ In order to prevent turbocharger failure, please allow more than 5 minutes' cool down period (no load low idle operation) before shutting the engine off.

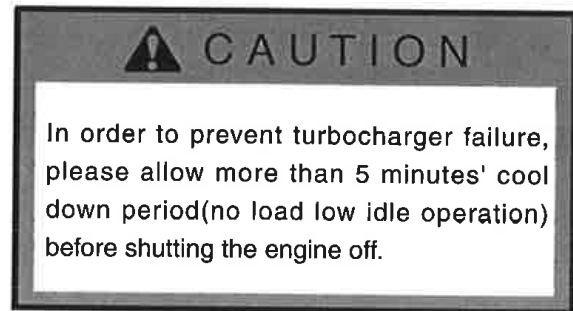

7807AFW20

31) REFLECTING (item 42)

This warning label is positioned on the rear of counterweight.

- ▲ To prevent serious personal injury or death keep clear of machine swing radius.
- ▲ Do not deface or remove this label from the machine.



21090FW70



32) ACCUMULATOR (item 43)

This warning label is positioned on the accumulator of the solenoid valve.

- ※ The accumulator is filled with high-pressure nitrogen gas, and it is extremely dangerous if it is handled in the wrong way. Always observe the following precautions.
- ▲ Never make any hole in the accumulator expose it to flame or fire.
- ▲ Do not weld anything to the accumulator.
- ※ When carrying out disassembly or maintenance of the accumulator, or when disposing of the accumulator, it is necessary to release the gas from the accumulator. A special air bleed valve is necessary for this operation, so please contact your Hyundai distributor.



1107A0FW46

33) CONTROL IDEOGRAM-RH (item 44)

This warning label is positioned on the RH console box.

- ▲ Check the machine control pattern for conformance to pattern on this label. If not, change label to match pattern before operating machine.
- ▲ Failure to do so could result in injury or death.
- ※ See page 4-11 for details.

WARNING

• THE MACHINE CONTROL PATTERN CAN EASILY BE CHANGED TO THE "ISO TYPE", "A TYPE", "C TYPE" OR "D TYPE" BY CHANGING THE POSITION OF THE LEVER-PATTERN.

• BEFORE STARTING THIS MACHINE, CHECK THE LEVER PATTERN VALVE.

• HOW TO USE :

1. LOOSEN THE BOLT.
2. MOVE LEVER TO THE "ISO", "A", "C" OR "D" POSITION.
3. AFTER SETTING THE PATTERN, TIGHTEN THE BOLT.

• REFER TO OPERATOR'S MANUAL FOR DETAILS.

ISO TYPE	A TYPE	C TYPE	D TYPE
<p>POSITION OF LEVER-PATTERN :</p>	<p>POSITION OF LEVER-PATTERN :</p>	<p>POSITION OF LEVER-PATTERN :</p>	<p>POSITION OF LEVER-PATTERN :</p>
LEFT CONTROL LEVER RIGHT CONTROL LEVER	LEFT CONTROL LEVER RIGHT CONTROL LEVER	LEFT CONTROL LEVER RIGHT CONTROL LEVER	LEFT CONTROL LEVER RIGHT CONTROL LEVER

21090FW21

GUIDE

1. DIRECTION

The direction of this manual indicate forward, backward, right and left on the standard of operator when the travel motor is in the rear and machine is on the traveling direction.

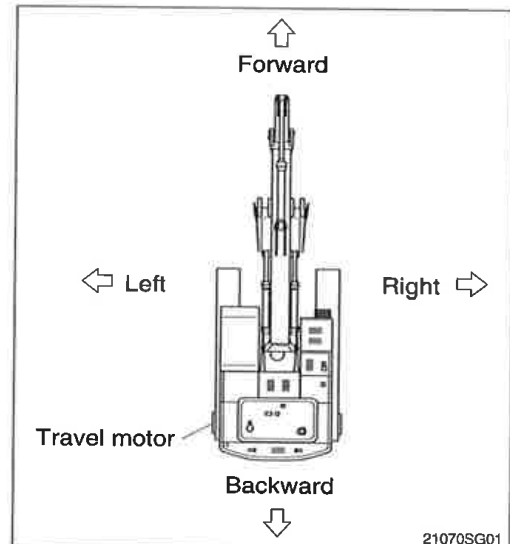

2. SERIAL NUMBER

Inform following when you order parts or the machine is out of order.

1) MACHINE SERIAL NUMBER

The numbers are located below the right window of the operator's cab.

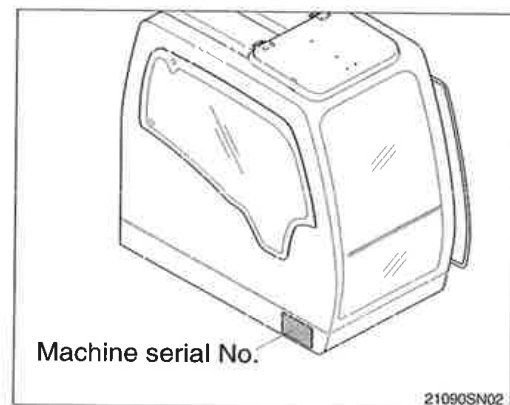

2) ENGINE SERIAL NUMBER

The numbers are located on the engine name plate.

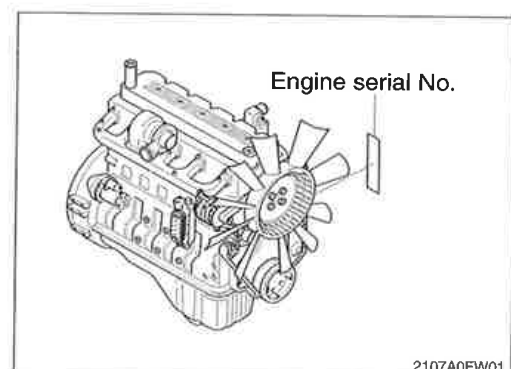

3. SYMBOLS

▲ Important safety hint.

△ It indicates matters which can cause the great loss on the machine or the surroundings.

※ It indicates the useful information for operator.

SAFETY HINTS

1. BEFORE OPERATING THE MACHINE

Think-safety first.

In special situation, wear protective clothing including a safety helmet, safety shoes, gloves, safety glasses and ear protection as required by the job condition.

Almost every accident is caused by disregarding the simple and fundamental safety hints.

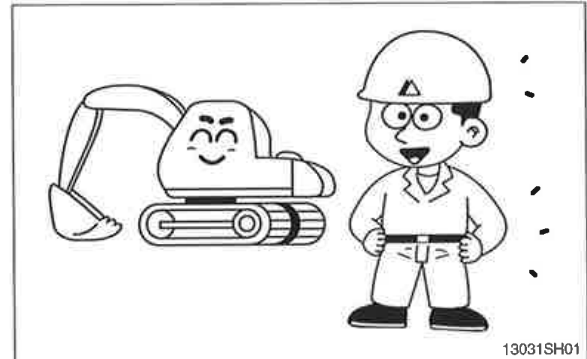

Be sure to understand thoroughly all about the operator's manual before operating the machine.

Proper care is your responsibility.

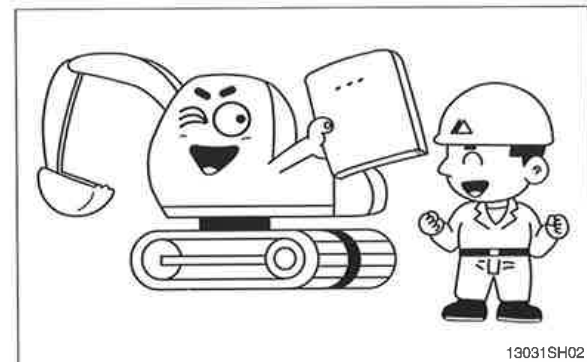

Fully understand the details and process of the construction before starting the work.

If you find anything dangerous on the job, consult with the job supervisor for the preventive measures before operating the machine.

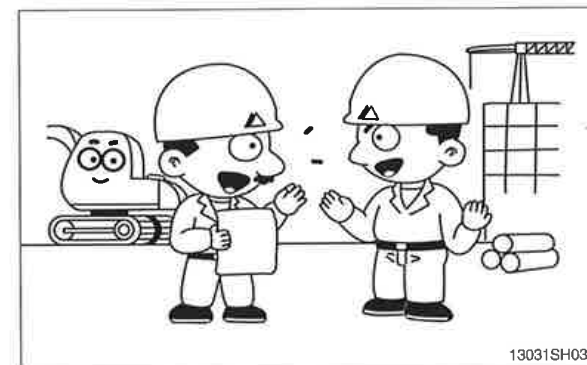

Do not operate when tired, or after drinking alcoholic beverages or any type of drugs.

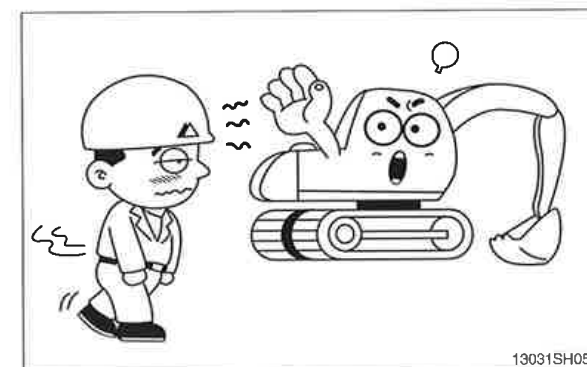



Check daily according to the operation manual.

Repair the damaged parts and tighten the loosened bolts.

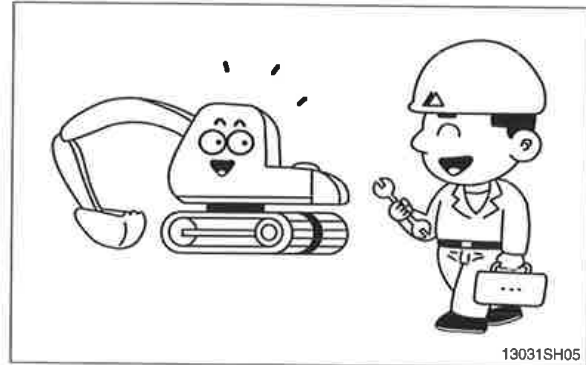

13031SH05

Check for leakage of engine oil, hydraulic oil, fuel and coolant.

Keep machine clean, clean machine regularly.

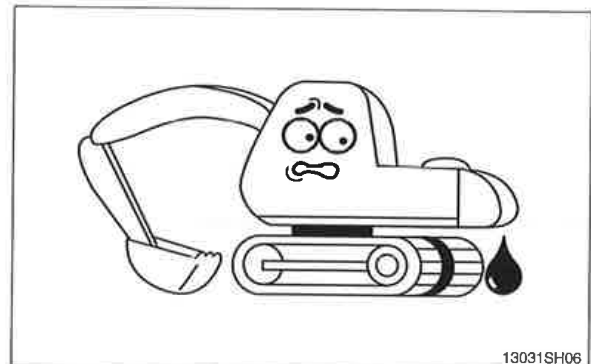

13031SH06

Do not operate the machine if it requires repairs.
Operate after complete repair.

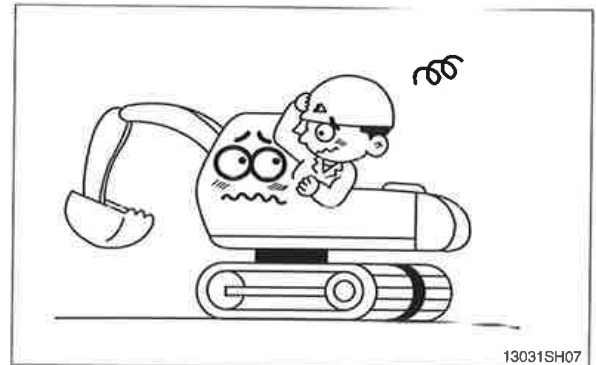

13031SH07

Be prepared if a fire starts.

Keep a fire extinguisher handy and emergency numbers for a fire department near your telephone.

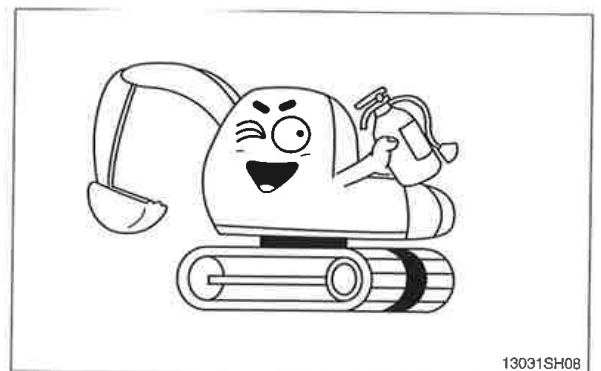

13031SH08

PROTECTION AGAINST FALLING OR FLYING OBJECTS

If there is any danger of falling or flying objects hitting the operator, install protective guards in place to protect the operator as required for each particular situation.

Be sure to close the front window before commencing work.

Make sure to keep all persons other than operator outside the range of falling or flying objects.

In case you need top guard, front guard and FOPS (falling object protective structure), please contact Hyundai distributor in Europe.

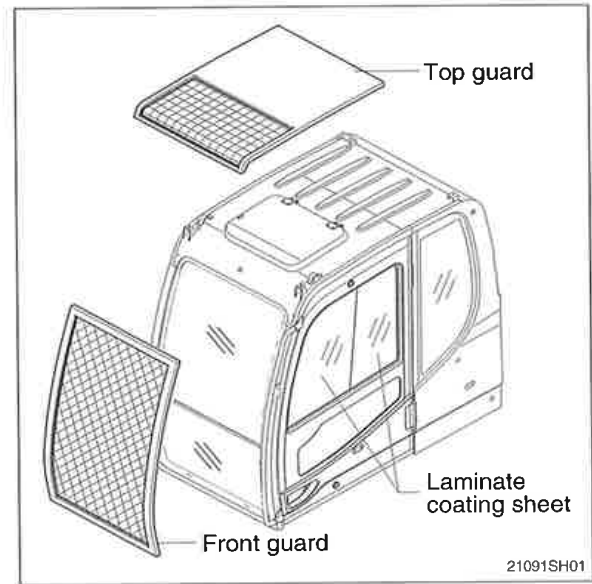

UNAUTHORIZED MODIFICATION

Any modification made without authorization from Hyundai can create hazards.

Before making a modification, consult your Hyundai distributor. Hyundai will not be responsible for any injury or damage caused by any unauthorized modification.

PREPARE FOR EMERGENCY

Only in case of emergency, use the installed hammer for breaking the windshield of the cab, and then exit carefully.

Be sure you know the phone numbers of persons you should contact in case of an emergency.

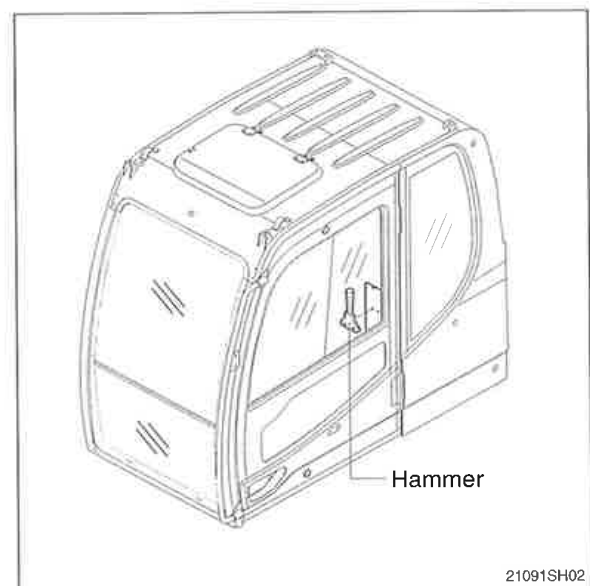

ROTATING BEACON

When you operate a machine on a road or beside a road, a rotating beacon is required to avoid any traffic accident.

Please contact your Hyundai distributor to install it.

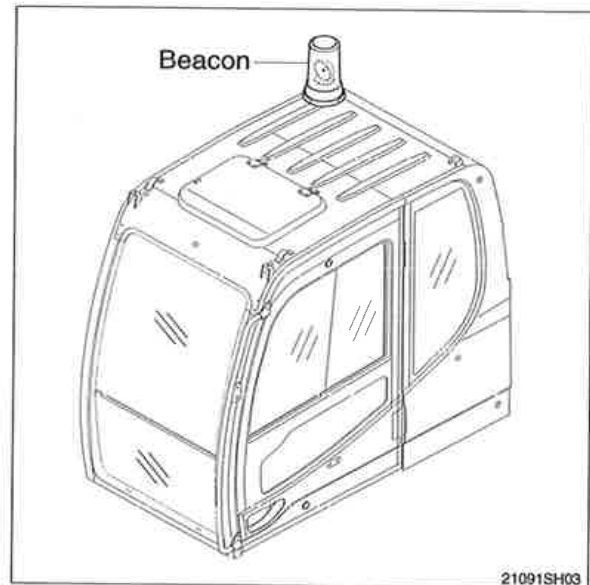

21091SH03

PRECAUTIONS FOR ATTACHMENTS

When installing and using an optional attachment, read the instruction manual for the attachment and the information related to attachments in this manual.

Do not use attachments that are not authorized by Hyundai or your Hyundai distributor. Use of unauthorized attachments could create a safety problem and adversely affect the proper operation and useful life of the machine.

Any injuries, accidents, product failures resulting from the use of unauthorized attachments are not the responsibility of Hyundai.

SAFETY RULES

Only trained and authorized personnel can operate and maintain the machine.

Follow all safety rules, precautions and instructions when operating or performing maintenance on the machine.

When working with another operator or a person on worksite traffic duty, be sure all personnel understand all hand signals that are to be used.



SAFETY FEATURES

Be sure all guards and covers are in their proper position. Have guards and covers repaired if damaged.

Use safety features such as safety lock and seat belts properly.

Never remove any safety features. **Always** keep them in good operating condition.

Improper use of safety features could result in serious bodily injury or death.

MACHINE CONTROL PATTERN

Check machine control pattern for conformance to pattern on label in cab.

If not, change label to match pattern before operating machine.

Failure to do so could result in injury.

CALIFORNIA PROPOSITION 65

Diesel engine exhaust and some of its constituents are known to the State of California to cause cancer, birth defects and other reproductive harm.

This product contains or emits chemicals known to the State of California to cause cancer or birth defects or other reproductive harm.

Battery posts, terminals and related accessories contain lead and lead compounds.

WASH HANDS AFTER HANDLING



13031SH55

Do not load the machine with the lifting eyes on the counterweight.

▲ The wrong loading method can result in serious bodily injury or death.

2. DURING OPERATING THE MACHINE

Use the handle and footstep when getting on or off the machine.

Do not jump on or off the machine.

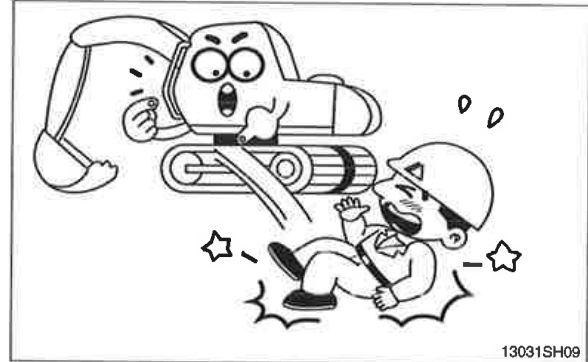

Sound the horn to warn nearby personnel before operating the machine.

Remove all the obstacles like frost on the window before operating the machine for the good visibility.

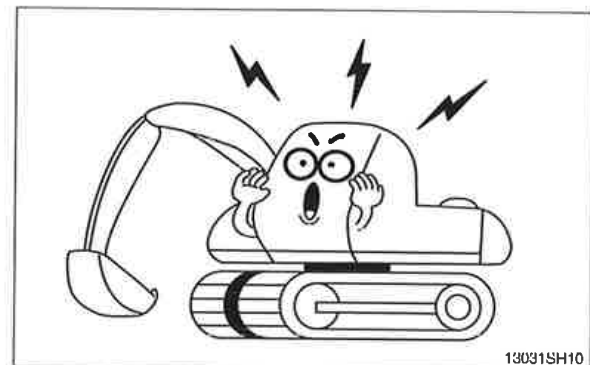

Operate carefully to make sure all personnel or obstacles are clear within the working range of the machine.

Place safety guards if necessary.

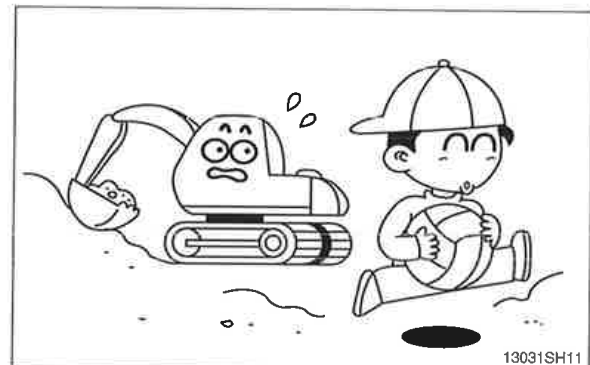

When using the work equipment, pay attention to job site.





Provide proper ventilation when operating engine in a closed area to avoid the danger of exhaust gases.

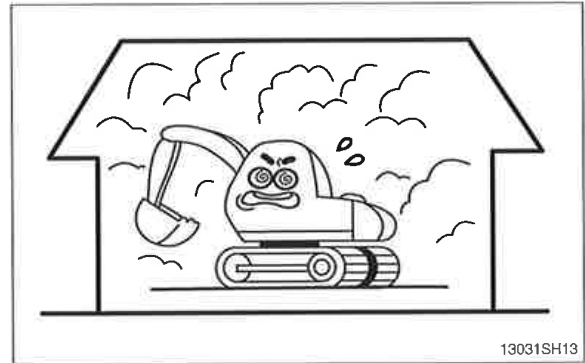

Check the locations of underground gas pipes or water line and secure the safety before operation.

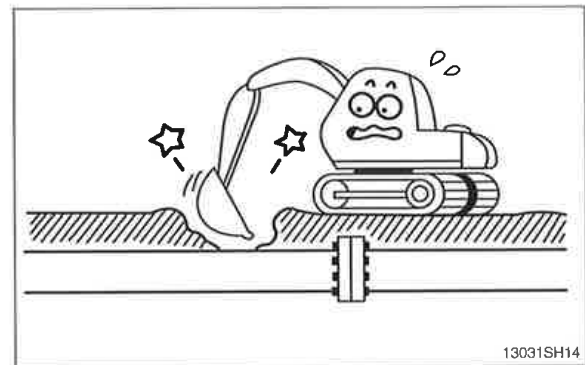

The operating near the electrical lines is very dangerous. Operate within safe working range permitted as below.

Supply voltage	Min safe separation
6.6 kV	3m (10 ft)
33.0 kV	4m (13 ft)
66.0 kV	5m (16 ft)
154.0 kV	8m (26 ft)
275.0 kV	10m (33 ft)

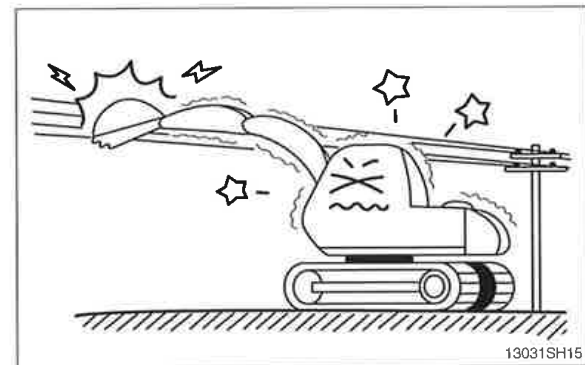

If the machine touches the electric power lines, keep sitting on the operator's seat and make sure the personnel on the ground not to touch the machine until turning off the electric current. Jump off the machine without contacting the machine when you need to get off.

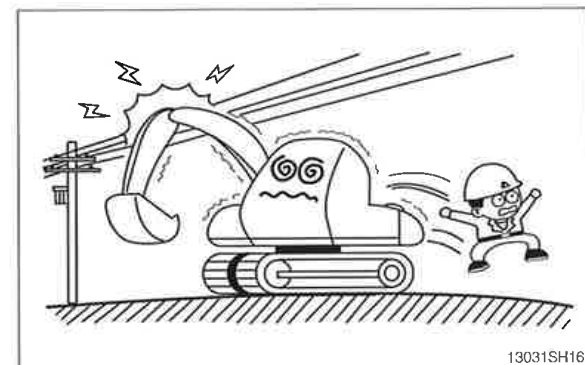

Watch out for obstacles.
Be particularly careful to check the machine clearance during the swing.

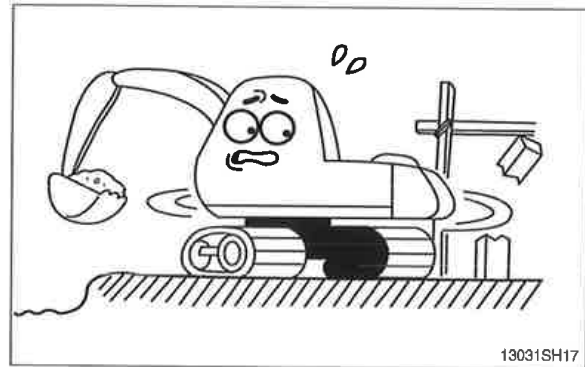

When using the machine as breaker or working in a place where stones may fall down, cab roof guard and head guard should be provided for proper protection.

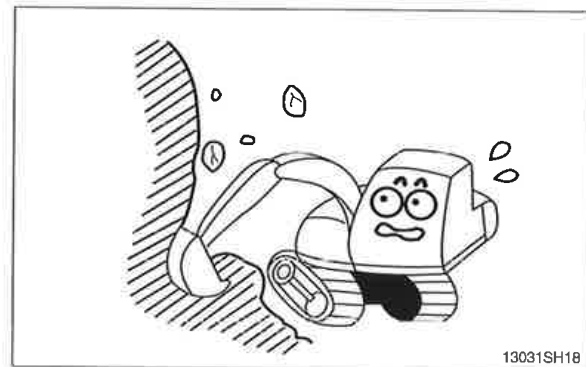

Avoid operating on a cliff or soft ground as there is danger of rolling over.
Make sure to get off easily as keeping the track at a right angle and putting the travel motor into the backward position when working on a cliff or soft ground inevitably.

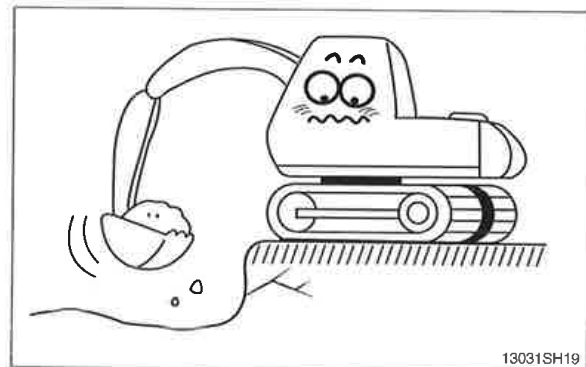

Operate for the lifting work considering the capacity of machine, weight and width of the load.
Be careful not to lift exceeding the machine capacity as it can be the cause of machine damage and safety accident.

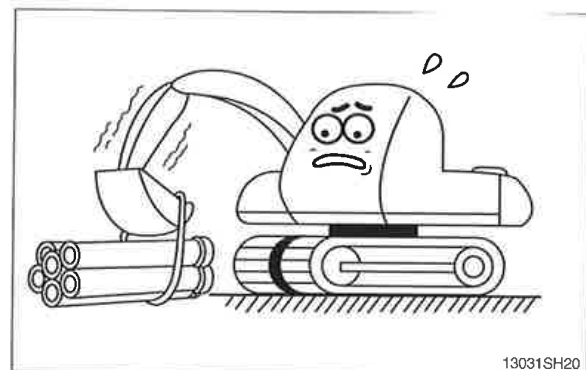

The operation on a slope is dangerous.
Avoid operating the machine on a slope of over
10 degree.

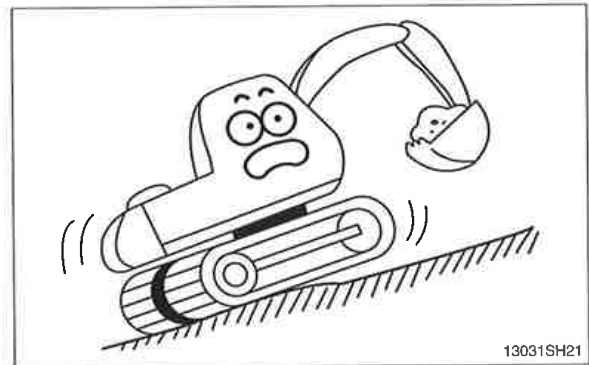

Operate the machine after making ground flat
when operation is required on a slope.

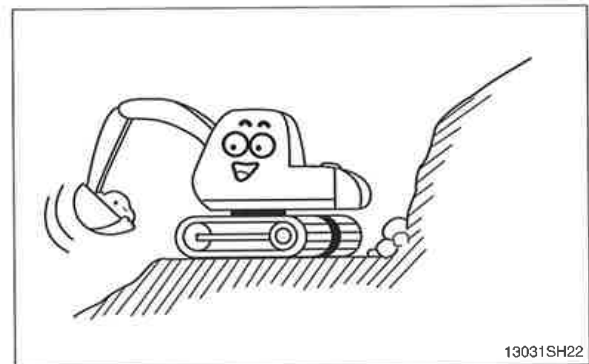

The swing on the slope can be danger of
rolling over.
Do not operate to swing the machine with the
bucket loaded on a slope since the machine
may lose its balance under such an instance.

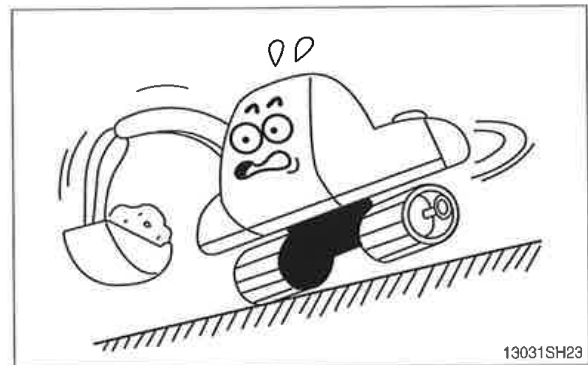

Avoid parking and stopping on a slope.
Lower the bucket to the ground and block the
track when parking.

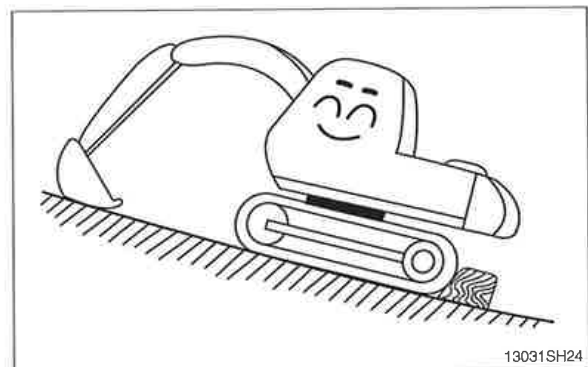

Avoid traveling in a cross direction on a slope as it can cause the danger of rolling over and sliding.

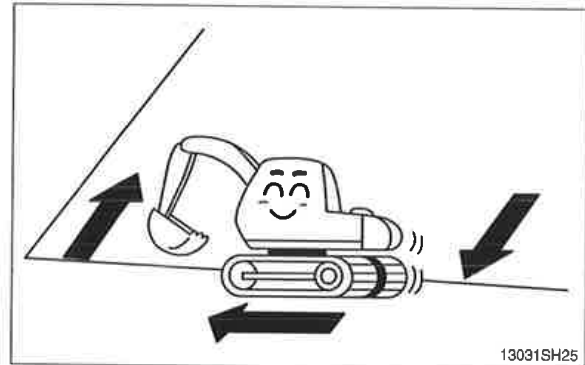

Traveling on a slope is dangerous. Be sure to operate slowly when traveling down a slope and maintain the bucket at a height of 20~30 cm (1 ft) above the ground so that it can be used as brake in an emergency.

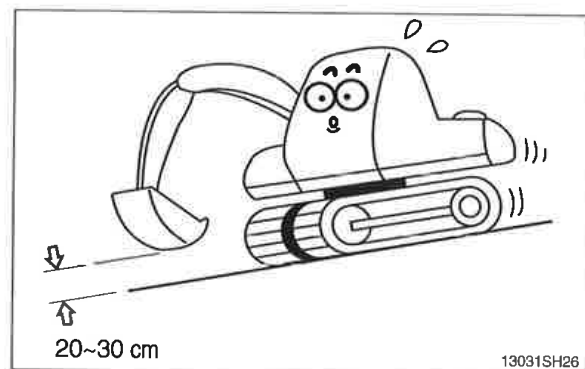

Steering of the machine while traveling on a slope is dangerous. When an inevitable turning of direction is required, turn on the flat and solid ground.

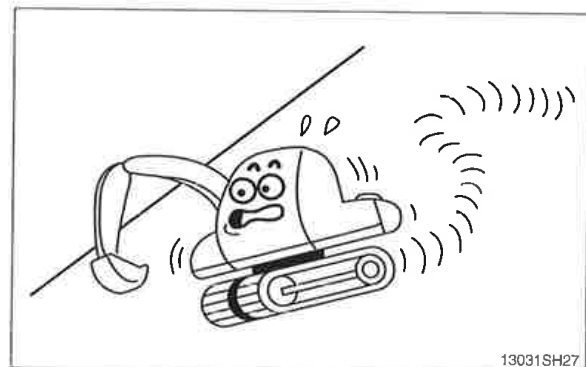

The engine angularity limits are 35 degree. Do not operate by more than the engine limits in any case.

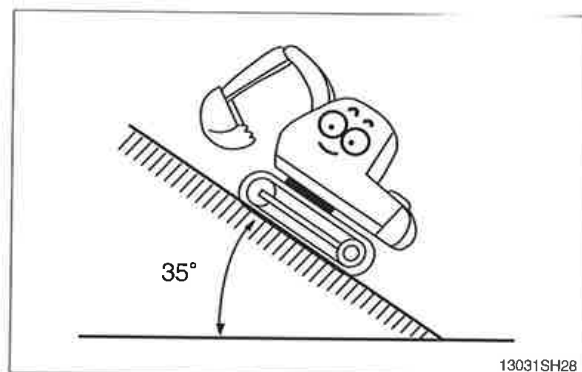

Before traveling the machine, sound the horn to warn nearby personnel.
Operate forward and backward correctly with confirming the location of the travel motor.

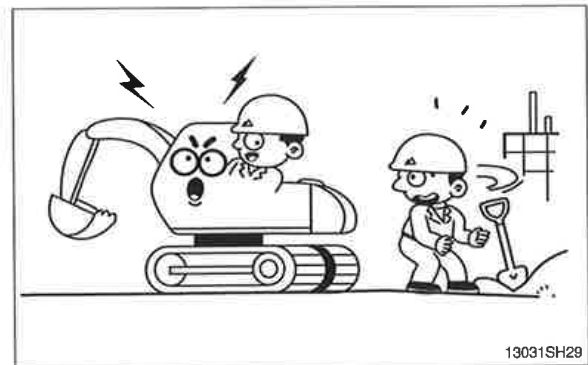

13031SH29

Slow down when traveling through obstacles or uneven ground.

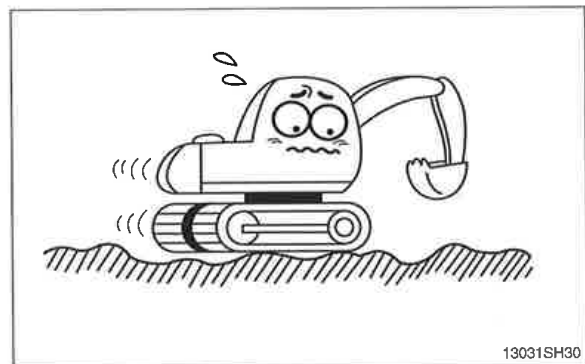

13031SH30

When working on soft ground, place mats or wood boards on the ground to prevent the machine sinking.

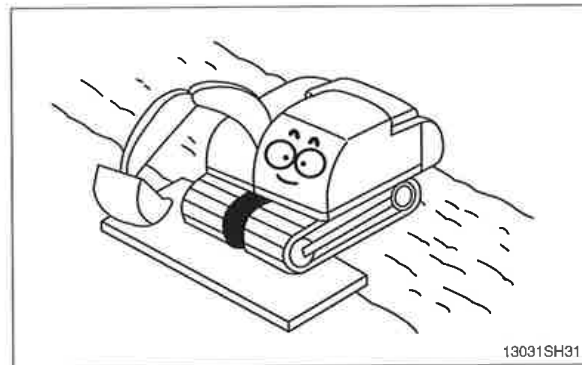

13031SH31

When operating in water or when crossing shallow, check the bed soil condition and depth and flow speed of water, then proceed taking care that water is not above carrier roller.

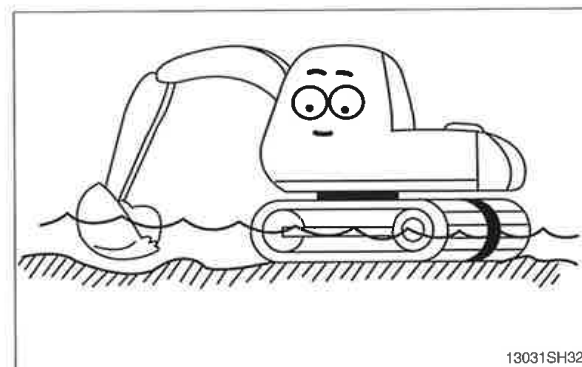

13031SH32

MOUNTING AND DISMOUNTING

Never jump on or off the machine. Never get on or off a moving machine.

When mounting or dismounting, always face the machine and use the handrails, machine or track frame steps, and track shoes. Additional track frame step can be fitted for wider optional shoe. In this case please contact your Hyundai distributor.

Do not hold any control levers when getting on or off the machine.

Ensure safety by always maintaining at least three-point contact of hands and feet with the handrails, steps or track shoes.

Always remove any oil or mud from the handrails, steps and track shoes. If they are damaged, repair them and tighten any loose bolts.

If grasping the door handrail when mounting or dismounting or moving on the track, open and lock the door securely in the open position. Otherwise, the door may move suddenly, causing you to lose balance and fall.

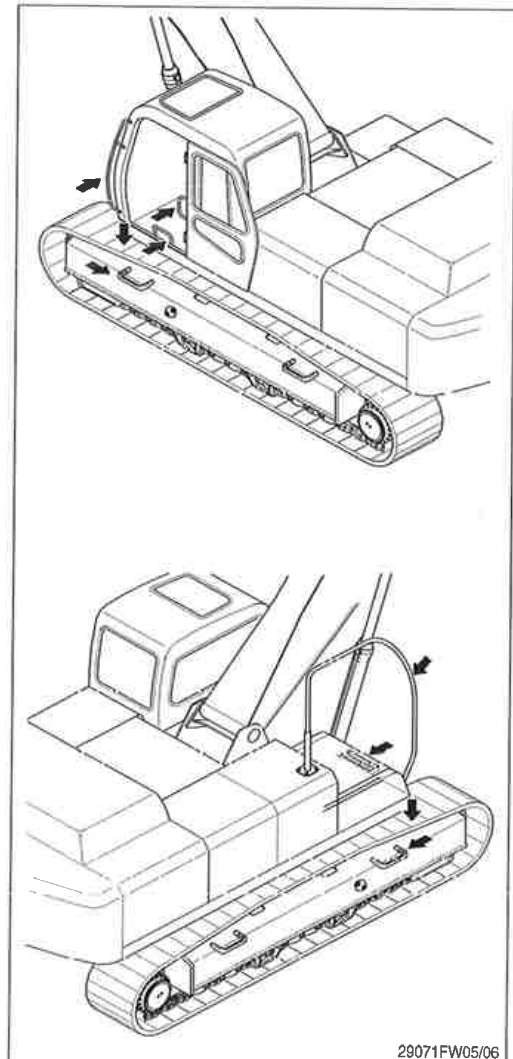

3. DURING MAINTENANCE

Stop the engine immediately when the trouble of the machine is found.

Inspect immediately the cause of trouble such as vibration, overheating and trouble in the cluster then repair.

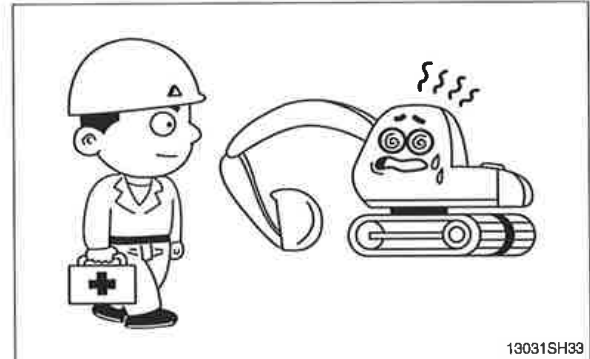

13031SH33

Park on a flat place and stop the engine for inspecting and repairing. Properly TAG machine is not operational. (remove start key)
Extreme care shall be taken during maintenance work. Parts may require additional safe guard.

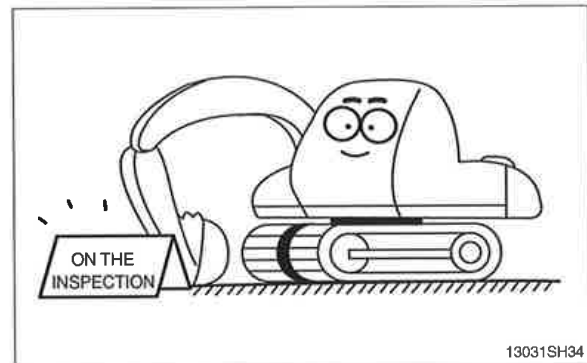

13031SH34

Do not remove the radiator cap from hot engine. Open the cap after the engine cools, below 50 °C (122 °F) to prevent personal injury from heated coolant spray or steam.



13031SH35

Do not work below the machine.
Be sure to work with proper safety supports.
Do not depend on the hydraulic cylinders to hold up the equipment and attachment.

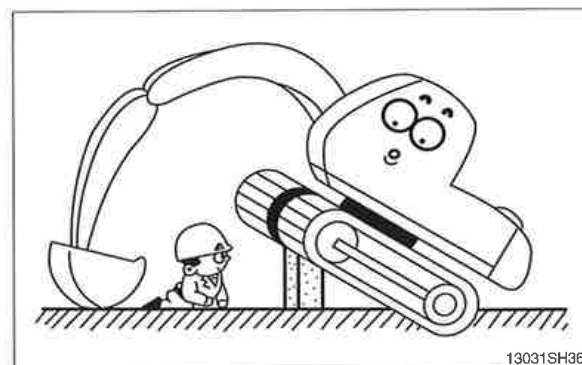

13031SH36



There is the danger of fire in fuel and oil.
Store in cool and dry area, away from any open flames.

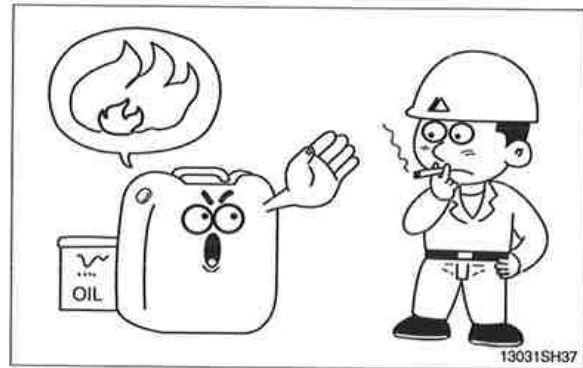

Do not touch exhaust pipe, or may cause severe burn.

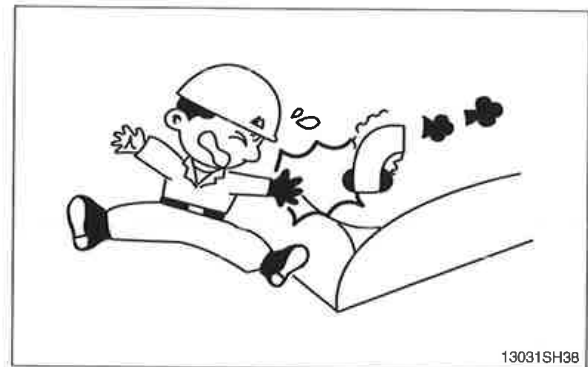

Do not open the engine hood and covers while the engine is running.

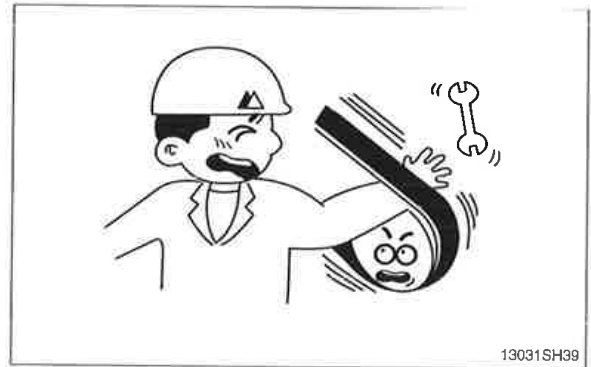

Be careful of not hitting the edges when you service engine.

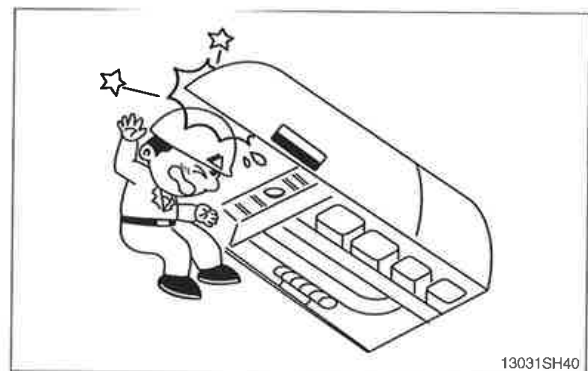

Be careful that the front window may be promptly closed.

Be sure to support stay, when the side door needs to be opened.

Be careful that the open side door may closed by the external or natural force like strong wind.



13031SH41

The antislip protection should be replaced if they have become worn or have been printed over.

Be sure to free of oil, water and grease etc.

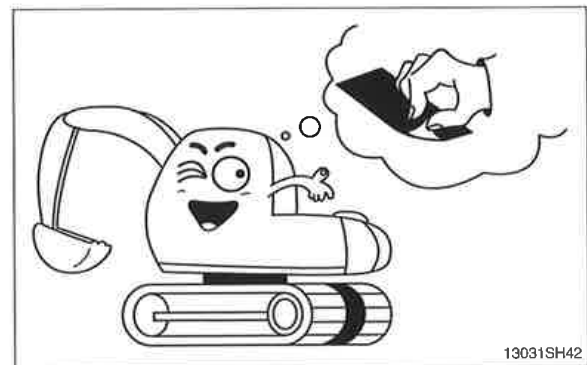

13031SH42

Be careful of not touching slip, fall down etc., when you work at the upper frame to service engine and/or other component.

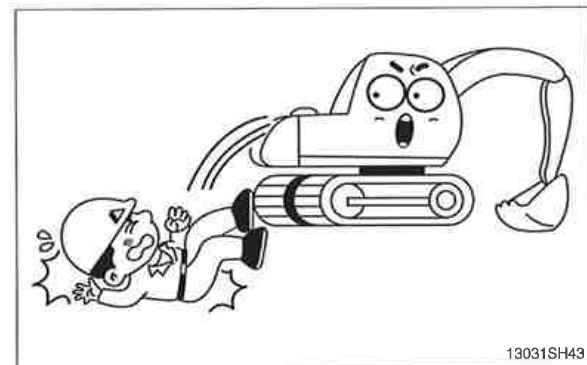

13031SH43

HIGH PRESSURE GAS

Contain high pressure gas.

To avoid explosion and personal injury, do not expose to fire, do not weld, do not drill.

Relieve pressure before discharging.

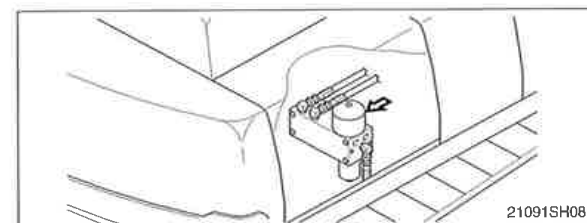

21091SH08

LIFT EYES CAN FAIL

Lift eyes or tank can fail when lifting tank containing fluids resulting in possible personal injury.

Drain tank of all fluids before lifting.



4. PARKING

When leaving the machine after parking, lower the bucket to the ground completely and put the safety lever at parking position then remove the key. Lock the cab door.

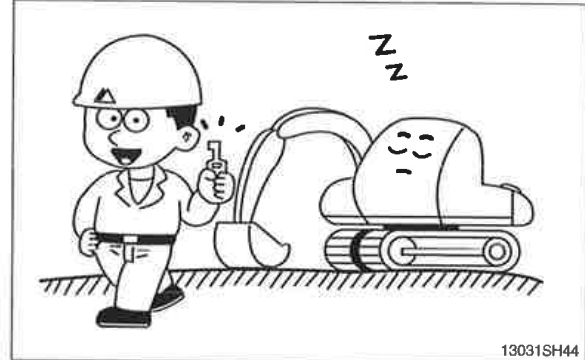

Park the machine in the flat and safe place.

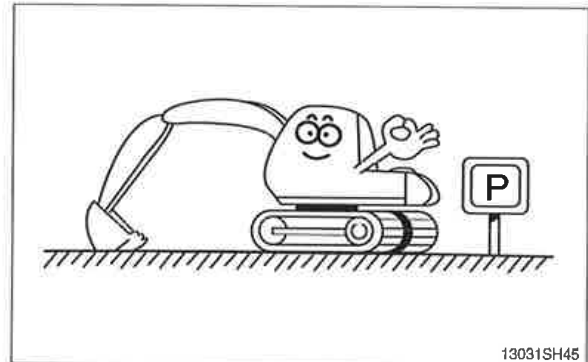

Hope you can work easily and safely observing safety rules.
For safe operation, observe all safety rules.

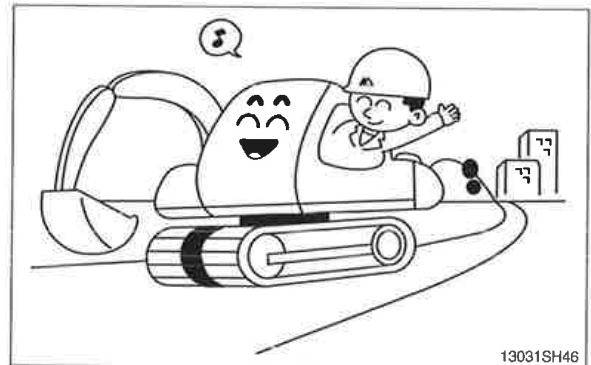

SPECIFICATIONS

1. MAJOR COMPONENT

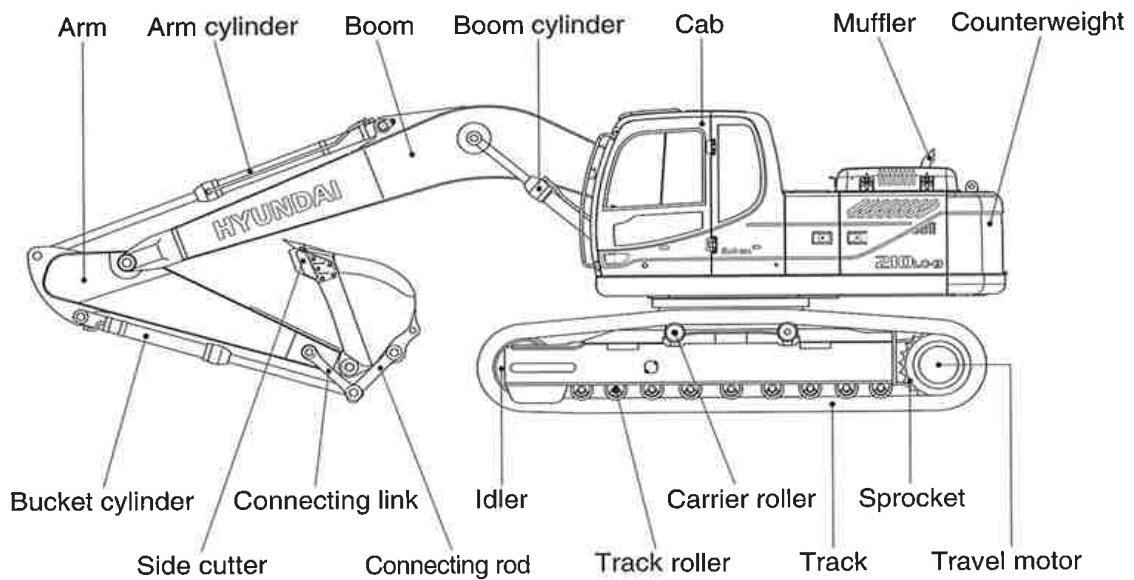
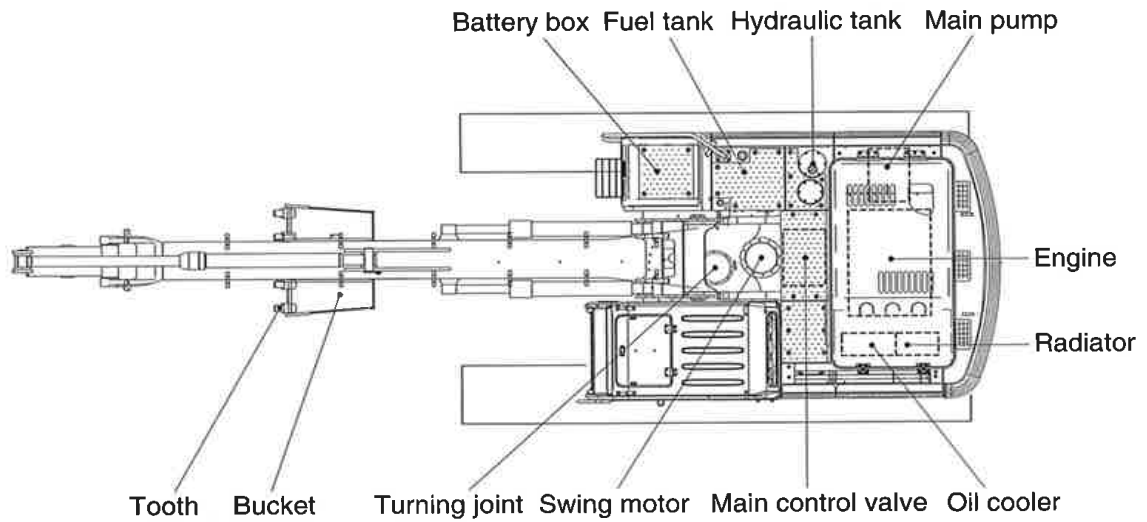

21092SP01



2. SPECIFICATIONS

1) R210LC-9

- 5.68 m (18' 8") BOOM and 2.92 m (9' 7") ARM

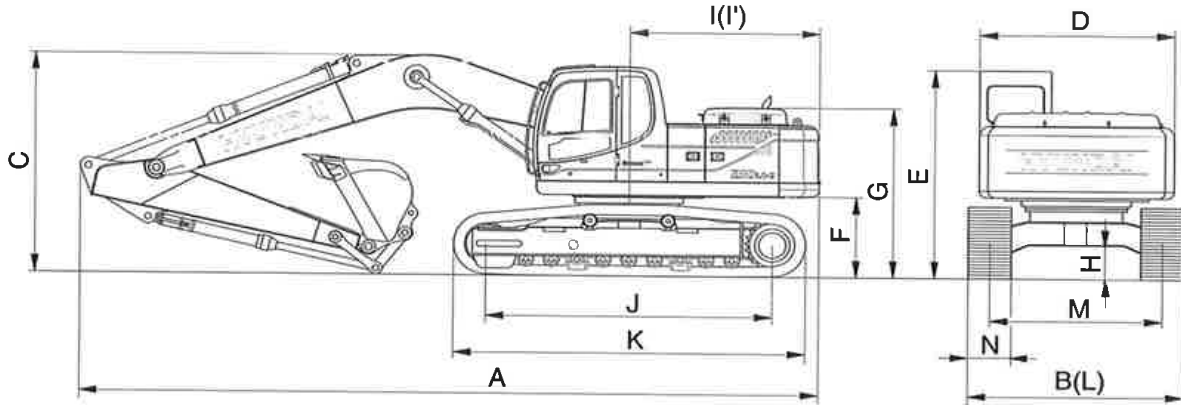

21092SP02

Description		Unit	Specification
Operating weight		kg (lb)	21900 (48280)
Bucket capacity (SAE heaped), standard		m ³ (yd ³)	0.92 (1.20)
Overall length	A	mm (ft-in)	9530 (31' 3")
Overall width, with 600mm shoe	B		2990 (9' 10")
Overall height	C		3030 (9' 11")
Superstructure width	D		2740 (9' 0")
Overall height of cab	E		2920 (9' 7")
Ground clearance of counterweight	F		1060 (3' 6")
Engine cover height	G		2320 (7' 7")
Minimum ground clearance	H		480 (1' 7")
Rear-end distance	I		2770 (9' 1")
Rear-end swing radius	I'		2840 (9' 4")
Distance between tumblers	J		3650 (12' 0")
Undercarriage length	K		4440 (14' 7")
Undercarriage width	L		2990 (9' 10")
Track gauge	M		2390 (7' 10")
Track shoe width, standard	N		600 (24")
Travel speed (low/high)			km/hr (mph)
Swing speed		rpm	12.0
Gradeability		Degree (%)	35 (70)
Ground pressure (600 mm shoe)		kgf/cm ² (psi)	0.46 (6.54)
Max traction force		kg (lb)	21100 (46500)



2) R210LC-9 LONG REACH

· 8.2 m (26' 11") BOOM and 6.3 m (20' 8") ARM

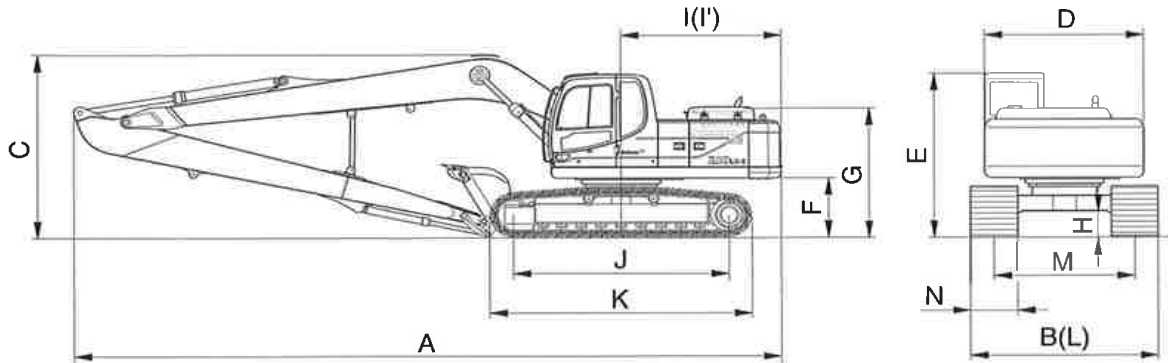

21092SP06

Description		Unit	Specification
Operating weight		kg (lb)	24360 (53700)
Bucket capacity (SAE heaped), standard		m ³ (yd ³)	0.51 (0.67)
Overall length	A	mm (ft-in)	12030 (39' 6")
Overall width, with 800 mm shoe	B		3190 (10' 6")
Overall height	C		3280 (10' 9")
Superstructure width	D		2740 (9' 0")
Overall height of cab	E		2920 (9' 7")
Ground clearance of counterweight	F		1060 (3' 6")
Engine cover height	G		2320 (7' 7")
Minimum ground clearance	H		480 (1' 7")
Rear-end distance	I		2770 (9' 1")
Rear-end swing radius	I'		2840 (9' 4")
Distance between tumblers	J		3650 (12' 0")
Undercarriage length	K		4440 (14' 7")
Undercarriage width	L		3190 (10' 6")
Track gauge	M		2390 (7' 10")
Track shoe width, standard	N		800 (32")
Travel speed (low/high)			km/hr (mph)
Swing speed		rpm	12.0
Gradeability		Degree (%)	35 (70)
Ground pressure (800 mm shoe)		kgf/cm ² (psi)	0.42 (5.97)
Max traction force		kg (lb)	21100 (46500)



3) R210LC-9 HIGH WALKER

· 5.68 m (18' 8") BOOM and 2.92 m (9' 7") ARM

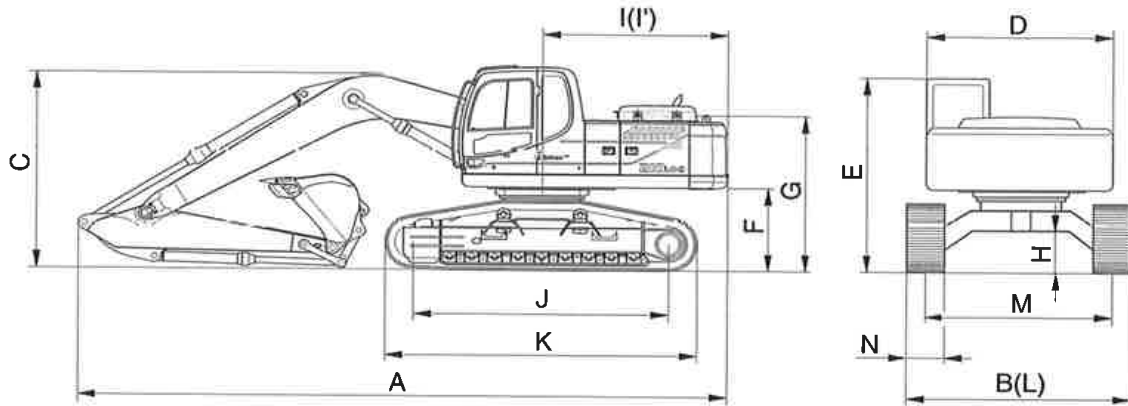

21092SP07

Description		Unit	Specification
Operating weight		kg (lb)	23160 (51060)
Bucket capacity (SAE heaped), standard		m ³ (yd ³)	0.92 (1.20)
Overall length	A	mm (ft-in)	9470 (31' 1")
Overall width, with 600 mm shoe	B		3395 (11' 2")
Overall height	C		3060 (10' 0")
Superstructure width	D		2740 (9' 0")
Overall height of cab	E		3100 (10' 2")
Ground clearance of counterweight	F		1240 (4' 1")
Engine cover height	G		2500 (8' 2")
Minimum ground clearance	H		660 (2' 2")
Rear-end distance	I		2770 (9' 1")
Rear-end swing radius	I'		2840 (9' 4")
Distance between tumblers	J		3650 (12' 0")
Undercarriage length	K		4440 (14' 7")
Undercarriage width	L		3395 (11' 2")
Track gauge	M		2795 (9' 2")
Track shoe width, standard	N		600 (24")
Travel speed (low/high)			km/hr (mph)
Swing speed		rpm	12.0
Gradeability		Degree (%)	35 (70)
Ground pressure (600 mm shoe)		kgf/cm ² (psi)	0.49 (6.97)
Max traction force		kg (lb)	21100 (46500)



3. WORKING RANGE

1) R210LC-9

· 5.68 m (18' 8") BOOM

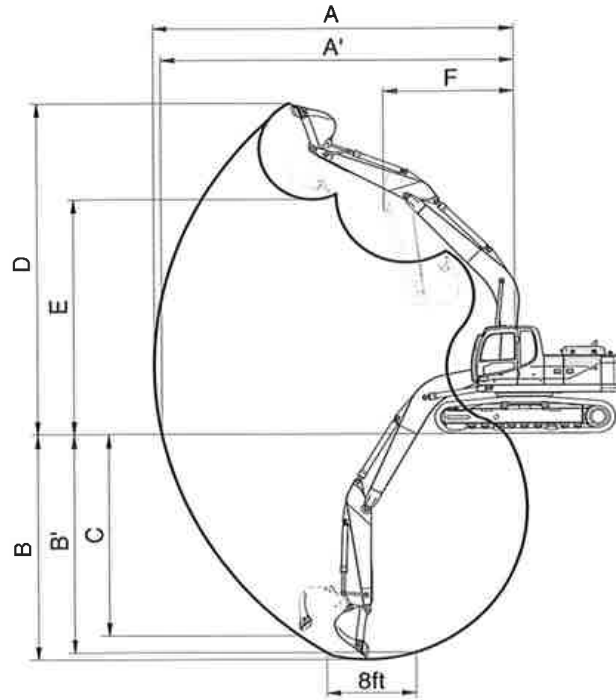

21092SP03

Description		2.0 m (6' 7") Arm	2.40 m (7' 10") Arm	2.92 m (9' 7") Arm	3.90 m (12' 10") Arm
Max digging reach	A	9140 mm (30' 0")	9500 mm (31' 2")	9980 mm (32' 9")	10910 mm (35' 10")
Max digging reach on ground	A'	8960 mm (29' 5")	9330 mm (30' 7")	9820 mm (32' 3")	10770 mm (35' 4")
Max digging depth	B	5820 mm (19' 1")	6220 mm (20' 5")	6730 mm (22' 1")	7720 mm (25' 4")
Max digging depth (8 ft level)	B'	5580 mm (18' 4")	6010 mm (19' 9")	6560 mm (21' 6")	7580 mm (24' 10")
Max vertical wall digging depth	C	5280 mm (17' 4")	5720 mm (18' 9")	6280 mm (20' 7")	7240 mm (23' 9")
Max digging height	D	9140 mm (30' 0")	9340 mm (30' 8")	9600 mm (31' 6")	10110 mm (33' 2")
Max dumping height	E	6330 mm (20' 9")	6520 mm (21' 5")	6780 mm (22' 3")	7290 mm (23' 11")
Min swing radius	F	3750 mm (12' 4")	3740 mm (12' 3")	3740 mm (12' 3")	3650 mm (11' 12")
Bucket digging force	SAE	130.4 [141.6] kN	130.4 [141.6] kN	130.4 [141.6] kN	130.4 [141.6] kN
		13300 [14440] kgf	13300 [14440] kgf	13300 [14440] kgf	13300 [14440] kgf
		29320 [31830] lbf	29320 [31830] lbf	29320 [31830] lbf	29320 [31830] lbf
	ISO	149.1 [161.8] kN	149.1 [161.8] kN	149.1 [161.8] kN	149.1 [161.8] kN
		15200 [16500] kgf	15200 [16500] kgf	15200 [16500] kgf	15200 [16500] kgf
		33510 [36380] lbf	33510 [36380] lbf	33510 [36380] lbf	33510 [36380] lbf
Arm digging force	SAE	144.2 [156.5] kN	119.6 [129.9] kN	102.0 [110.7] kN	84.3 [91.6] kN
		14700 [15960] kgf	12200 [13250] kgf	10400 [11290] kgf	8600 [9340] kgf
		32410 [35190] lbf	26900 [29210] lbf	22930 [24900] lbf	18960 [20590] lbf
	ISO	151.0 [164.0] kN	125.5 [136.3] kN	106.9 [116.1] kN	87.3 [94.8] kN
		15400 [16720] kgf	12800 [13900] kgf	10900 [11830] kgf	8900 [9660] kgf
		33950 [36860] lbf	28220 [30640] lbf	24030 [26090] lbf	19620 [21300] lbf

[] : Power boost

2) R210LC-9 LONG REACH
· 8.2 m (26' 11") BOOM

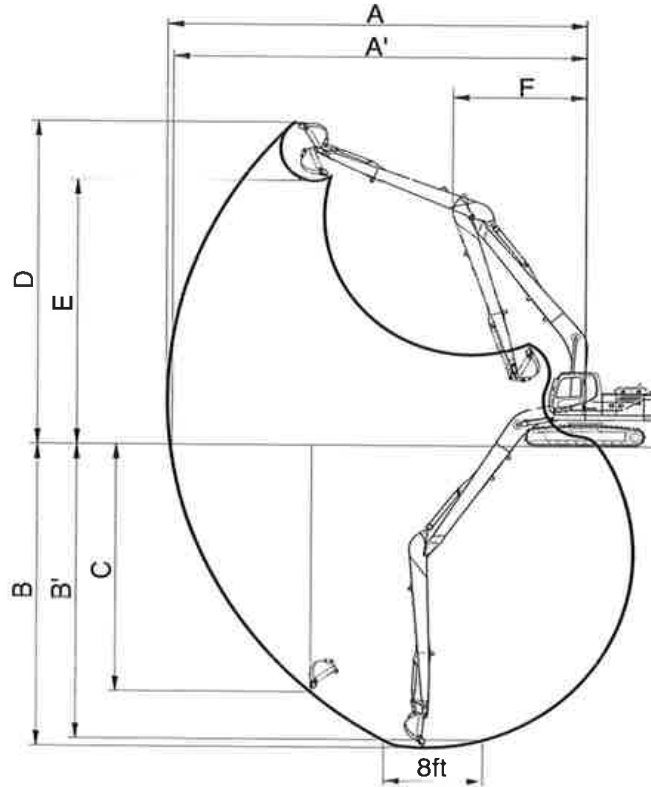

210925F08

Description		6.3 m (20' 8") Arm	
Max digging reach	A	15220 (50' 0")	
Max digging reach on ground	A'	15120 (49' 7")	
Max digging depth	B	11760 (38' 7")	
Max digging depth (8 ft level)	B'	11650 (38' 3")	
Max vertical wall digging depth	C	9610 (31' 6")	
Max digging height	D	12550 (41' 2")	
Max dumping height	E	10280 (33' 8")	
Min swing radius	F	4870 (16' 0")	
Bucket digging force	SAE	72.6 kN	
		7400 kgf	
		16310 lbf	
	ISO	83.4 kN	
		8500 kgf	
		18740 lbf	
Arm crowd force	SAE	49.0 kN	
		5000 kgf	
		11020 lbf	
	ISO	50.0 kN	
		5100 kgf	
		11240 lbf	

3) R210LC-9 HIGH WALKER
· 5.68 m (18' 8") BOOM

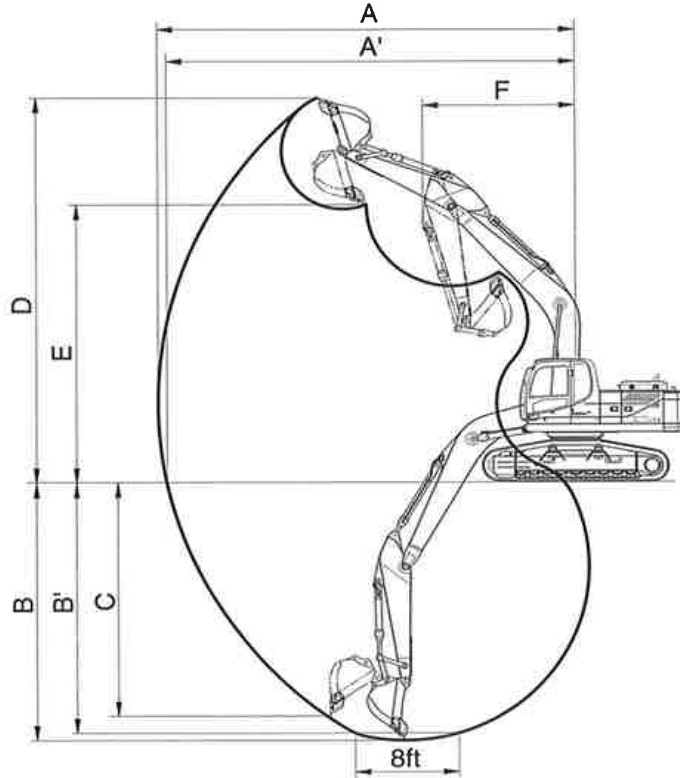

21092SP09

Description		2.0 m (6' 7") Arm	2.40 m (7' 10") Arm	2.92 m (9' 7") Arm	3.90 m (12'10") Arm
Max digging reach	A	9140 mm (30' 0")	9500 mm (31' 2")	9980 mm (32' 9")	10910 mm (35'10")
Max digging reach on ground	A'	8920 mm (29' 3")	9290 mm (30' 6")	9820 mm (32' 3")	10730 mm (35' 2")
Max digging depth	B	5630 mm (18' 6")	6010 mm (19' 9")	6550 mm (21' 6")	7530 mm (24' 8")
Max digging depth (8 ft level)	B'	5390 mm (17' 8")	5820 mm (19' 1")	6380 mm (20'11")	7390 mm (24' 3")
Max vertical wall digging depth	C	5090 mm (16' 8")	5630 mm (18' 6")	6100 mm (20' 0")	7050 mm (23' 1")
Max digging height	D	9330 mm (30' 7")	9530 mm (31' 3")	9780 mm (32' 1")	10300 mm (33' 9")
Max dumping height	E	6520 mm (21' 5")	6710 mm (22' 0")	6960 mm (22'10")	7480 mm (24' 6")
Min swing radius	F	3750 mm (12' 4")	3740 mm (12' 3")	3740 mm (12' 3")	3650 mm (11'12")
Bucket digging force	SAE	130.4 [141.6] kN	130.4 [141.6] kN	130.4 [141.6] kN	130.4 [141.6] kN
		13300 [14440] kgf	13300 [14440] kgf	13300 [14440] kgf	13300 [14440] kgf
		29320 [31830] lbf	29320 [31830] lbf	29320 [31830] lbf	29320 [31830] lbf
	ISO	149.1 [161.8] kN	149.1 [161.8] kN	149.1 [161.8] kN	149.1 [161.8] kN
		15200 [16500] kgf	15200 [16500] kgf	15200 [16500] kgf	15200 [16500] kgf
		33510 [36380] lbf	33510 [36380] lbf	33510 [36380] lbf	33510 [36380] lbf
Arm crowd force	SAE	144.2 [156.5] kN	119.6 [129.9] kN	102.0 [110.7] kN	84.3 [91.6] kN
		14700 [15960] kgf	12200 [13250] kgf	10400 [11290] kgf	8600 [9340] kgf
		32410 [35190] lbf	26900 [29210] lbf	22930 [24900] lbf	18960 [20590] lbf
	ISO	151.0 [164.0] kN	125.5 [136.3] kN	106.9 [116.1] kN	87.3 [94.8] kN
		15400 [16720] kgf	12800 [13900] kgf	10900 [11830] kgf	8900 [9660] kgf
		33950 [36860] lbf	28220 [30640] lbf	24030 [26090] lbf	19620 [21300] lbf

[] : Power boost



4. WEIGHT

1) R210LC-9

Item	R210LC-9	
	kg	lb
Upperstructure assembly	9400	20720
Main frame weld assembly	1920	4230
Engine assembly	560	1240
Main pump assembly	140	310
Main control valve assembly	220	485
Swing motor assembly	240	530
Hydraulic oil tank assembly	240	530
Fuel tank assembly	195	430
Counterweight	3800	8380
Cab assembly	310	680
Lower chassis assembly	8700	19180
Track frame weld assembly	2720	6000
Swing bearing	290	640
Travel motor assembly	300	660
Turning joint	55	120
Track recoil spring	140	310
Idler	170	370
Carrier roller	20	45
Track roller	40	90
Track-chain assembly (600 mm standard triple grouser shoe)	1350	2980
Front attachment assembly (5.68 m boom, 2.92 m arm, 0.92 m ³ SAE heaped bucket)	4030	8880
5.68 m boom assembly	1520	3350
2.92 m arm assembly	750	1650
0.92 m ³ SAE heaped bucket	765	1690
Boom cylinder assembly	180	400
Arm cylinder assembly	290	640
Bucket cylinder assembly	175	390
Bucket control link assembly	170	370



2) R210LC-9 LONG REACH

Item	R210LC-9 LONG REACH	
	kg	lb
Upperstructure assembly	9400	20720
Main frame weld assembly	1920	4230
Engine assembly	560	1240
Main pump assembly	140	310
Main control valve assembly	220	485
Swing motor assembly	240	530
Hydraulic oil tank assembly	240	530
Fuel tank assembly	195	430
Counterweight	5300	11680
Cab assembly	310	680
Lower chassis assembly	8700	19180
Track frame weld assembly	2720	6000
Swing bearing	290	640
Travel motor assembly	300	660
Turning joint	55	120
Track recoil spring	140	310
Idler	170	370
Carrier roller	20	45
Track roller	40	90
Track-chain assembly (800 mm standard triple grouser shoe)	1660	3660
Front attachment assembly (8.2 m boom, 6.3 m arm, 0.52 m ³ SAE heaped bucket)	4600	10140
8.2 m boom assembly	2105	4640
6.3 m arm assembly	1100	2430
0.52 m ³ SAE heaped bucket	465	1030
Boom cylinder assembly	180	400
Arm cylinder assembly	270	600
Bucket cylinder assembly	130	290
Bucket control rod assembly	170	370



3) R210LC-9 HIGH WALKER

Item	R210LC-9 HIGH WALKER	
	kg	lb
Upperstructure assembly	9430	20790
Main frame weld assembly	1950	4300
Engine assembly	560	1240
Main pump assembly	140	310
Main control valve assembly	220	485
Swing motor assembly	240	530
Hydraulic oil tank assembly	240	530
Fuel tank assembly	195	430
Counterweight	3800	8380
Cab assembly	310	680
Lower chassis assembly	9015	19870
Track frame weld assembly	3730	8220
Swing bearing	290	640
Travel motor assembly	300	660
Turning joint	55	120
Track recoil spring	140	310
Idler	170	370
Carrier roller	20	45
Track roller	40	90
Track-chain assembly (600 mm standard triple grouser shoe)	1350	2980
Front attachment assembly (5.68 m boom, 2.92 m arm, 0.92 m ³ SAE heaped bucket)	4030	8880
5.68 m boom assembly	1520	3350
2.92 m arm assembly	750	1650
0.92 m ³ SAE heaped bucket	765	1690
Boom cylinder assembly	180	400
Arm cylinder assembly	290	640
Bucket cylinder assembly	175	390
Bucket control rod assembly	170	370













5. LIFTING CAPACITIES

1) ROBEX 210LC-9

(1) 5.68 m (18' 8") boom, 2.00 m (6' 7") arm equipped with 0.92 m³ (SAE heaped) bucket, 600 mm (24") triple grouser shoe and 3800 kg counterweight.

 : Rating over-front
  : Rating over-side or 360 degree

Load point height		Load radius								At max. reach		
		3.0 m (10 ft)		4.5 m (15 ft)		6.0 m (20 ft)		7.5 m (25 ft)		Capacity		Reach m (ft)
												
7.5 m (25 ft)	kg lb									*4010 *8840	*4010 *8840	6.65 (21.8)
6.0 m (20 ft)	kg lb					*4440 *9790	*4440 *9790			*4060 *8950	3040 6700	7.78 (25.5)
4.5 m (15 ft)	kg lb			*5730 *12630	*5730 *12630	*4860 *10710	4630 10210			*4190 *9240	2540 5600	8.43 (27.7)
3.0 m (10 ft)	kg lb			*7460 *16450	6840 15080	*5610 *12370	4370 9630	*4830 *10650	3000 6610	4040 8910	2310 5090	8.74 (28.7)
1.5 m (5 ft)	kg lb			*8990 *19820	6320 13930	*6390 *14090	4120 9080	5060 11160	2890 6370	3990 8800	2260 4980	8.73 (28.6)
Ground Line	kg lb			*9690 *21360	6090 13430	*6910 *15230	3950 8710	4980 10980	2810 6190	4200 9260	2380 5250	8.42 (27.6)
-1.5 m (-5 ft)	kg lb	*13990 *30840	12260 27030	*9630 *21230	6070 13380	*6990 *15410	3910 8620			4820 10630	2750 6060	7.76 (25.5)
-3.0 m (-10 ft)	kg lb	*12500 *27560	12500 27560	*8820 *19440	6180 13620	*6350 *14000	3990 8800			*4850 *10690	3650 8050	6.61 (21.7)
-4.5 m (-15 ft)	kg lb	*9460 *20860	*9460 *20860									

- Note
1. Lifting capacity are based on SAE J1097 and ISO 10567.
 2. Lifting capacity of the ROBEX series does not exceed 75% of tipping load with the machine on firm, level ground or 87% of full hydraulic capacity.
 3. The load point is a hook located on the back of the bucket.
 4. *indicates load limited by hydraulic capacity.



(2) 5.68 m (18' 8") boom, 2.40 m (7' 10") arm equipped with 0.92 m³ (SAE heaped) bucket, 600 mm (24") triple grouser shoe and 3800 kg counterweight.

Load point height		Load radius										At max. reach					
		1.5 m (5 ft)		3.0 m (10 ft)		4.5 m (15 ft)		6.0 m (20 ft)		7.5 m (25 ft)		Capacity		Reach			
														m (ft)			
7.5 m (25 ft)	kg lb																
6.0 m (20 ft)	kg lb							*4010 *8840	*4010 *8840					*3700 *8160	3640 8020		7.15 (23.5)
4.5 m (15 ft)	kg lb							*4490 *9900	*4490 *9900	*4230 *9330	3130 6900			*3900 *8600	2340 5160		8.82 (28.9)
3.0 m (10 ft)	kg lb					*6900 *15210	*6900 *15210	*5280 *11640	4400 9700	*4560 *10050	3010 6640			3760 8290	2130 4700		9.11 (29.9)
1.5 m (5 ft)	kg lb					*8560 *18870	6380 14070	*6120 *13490	4130 9110	*4970 *10960	2880 6350			3710 8180	2080 4590		9.10 (29.9)
Ground Line	kg lb			*8790 *19380	*8790 *19380	*9490 *20920	6080 13400	*6740 *14860	3930 8660	4950 10910	2780 6130			3890 8580	2180 4810		8.81 (28.9)
-1.5 m (-5 ft)	kg lb	*9760 *21520	*9760 *21520	*13510 *29780	12060 26590	*9650 *21270	6000 13230	*6960 *15340	3850 8490					4390 9680	2480 5470		8.18 (26.8)
-3.0 m (-10 ft)	kg lb	*14150 *31200	*14150 *31200	*13240 *29190	12280 27070	*9090 *20040	6080 13400	*6590 *14530	3900 8600					*4700 *10360	3190 7030		7.12 (23.4)
-4.5 m (-15 ft)	kg lb			*10630 *23440	*10630 *23440	*7400 *16310	6330 13960										

(3) 5.68 m (18' 8") boom, 2.92 m (9' 7") arm equipped with 0.92 m³ (SAE heaped) bucket, 600 mm (24") triple grouser shoe and 3800 kg counterweight.

Load point height		Load radius										At max. reach					
		1.5 m (5 ft)		3.0 m (10 ft)		4.5 m (15 ft)		6.0 m (20 ft)		7.5 m (25 ft)		Capacity		Reach			
														m (ft)			
7.5 m (25 ft)	kg lb																
6.0 m (20 ft)	kg lb									*2340 *5160	*2340 *5160			*3450 *7610	2460 5420		8.74 (28.7)
4.5 m (15 ft)	kg lb							*4010 *8840	*4010 *8840	*3830 *8440	3180 7010			*3580 *7890	2100 4630		9.32 (30.6)
3.0 m (10 ft)	kg lb			*9780 *21560	*9780 *21560	*6150 *13560	*6150 *13560	*4840 *10670	4460 9830	*4230 *9330	3040 6700			3440 7580	1930 4250		9.59 (31.5)
1.5 m (5 ft)	kg lb			*8810 *19420	*8810 *19420	*7960 *17550	6490 14310	*5750 *12680	4160 9170	*4710 *10380	2880 6350			3390 7470	1880 4140		9.59 (31.5)
Ground Line	kg lb			*9550 *21050	*9550 *21050	*9160 *20190	6090 13430	*6490 *14310	3920 8640	4930 10870	2750 6060			3520 7760	1950 4300		9.31 (30.5)
-1.5 m (-5 ft)	kg lb	*8810 *19420	*8810 *19420	*12610 *27800	11870 26170	*9600 *21160	5940 13100	*6870 *15150	3800 8380	4860 10710	2690 5930			3920 8640	2190 4830		8.72 (28.6)
-3.0 m (-10 ft)	kg lb	*12190 *26870	*12190 *26870	*13980 *30820	12040 26540	*9320 *20550	5960 13140	*6740 *14860	3800 8380					*4460 *9830	2710 5970		7.75 (25.4)
-4.5 m (-15 ft)	kg lb			*11860 *26150	*11860 *26150	*8120 *17900	6140 13540							*4330 *9550	4080 8990		6.16 (20.2)



(4) 5.68 m (18' 8") boom, 3.90 m (12' 10") arm equipped with 0.92 m³ (SAE heaped) bucket, 600 mm (24") triple grouser shoe and 3800 kg counterweight.

Load point height		Load radius												At max. reach			
		1.5 m (5 ft)		3.0 m (10 ft)		4.5 m (15 ft)		6.0 m (20 ft)		7.5 m (25 ft)		9.0 m (30 ft)		Capacity		Reach	
																	m (ft)
9.0 m (30 ft)	kg lb														*2740 *6040	*2740 *6040	7.66 (25.1)
7.5 m (25 ft)	kg lb								*1980 *4370	*1980 *4370					*2800 *6170	2420 5340	8.94 (29.3)
6.0 m (20 ft)	kg lb								*2840 *6260	*2840 *6260					*2900 *6390	1960 4320	9.77 (32.1)
4.5 m (15 ft)	kg lb								*3090 *6810	*3090 *6810	*2040 *4500	*2040 *4500			*3020 *6660	1700 3750	10.28 (33.7)
3.0 m (10 ft)	kg lb							*3940 *8690	*3940 *8690	*3560 *7850	3080 6790	*2910 *6420	2140 4720		2890 6370	1560 3440	10.52 (34.5)
1.5 m (5 ft)	kg lb			*11130 *24540	*11130 *24540	*6640 *14640	*6640 *14640	*4950 *10910	4220 9300	*4120 *9080	2880 6350	*3450 *7610	2040 4500		2840 6260	1510 3330	10.52 (34.5)
Ground Line	kg lb	*5260 *11600	*5260 *11600	*10600 *23370	*10600 *23370	*8250 *18190	6130 13510	*5860 *12920	3910 8620	*4650 *10250	2710 5970	*3530 *7780	1950 4300		2930 6460	1550 3420	10.27 (33.7)
-1.5 m (-5 ft)	kg lb	*7500 *16530	*7500 *16530	*11650 *25680	11540 25440	*9150 *20170	5810 12810	*6490 *14310	3700 8160	4750 10470	2590 5710	*2370 *5220	1900 4190		3180 7010	1700 3750	9.75 (32.0)
-3.0 m (-10 ft)	kg lb	*9990 *22020	*9990 *22020	*14350 *31640	11540 25440	*9360 *20640	5720 12610	*6700 *14770	3620 7980	4710 10380	2550 5620				3710 8180	2030 4480	8.91 (29.2)
-4.5 m (-15 ft)	kg lb	*12960 *28570	*12960 *28570	*13360 *29450	11780 25970	*8830 *19470	5800 12790	*6340 *13980	3670 8090						*4030 *8880	2730 6020	7.62 (25.0)
-6.0 m (-20 ft)	kg lb			*10610 *23390	*10610 *23390	*7100 *15650	6080 13400										



2) R210LC-9 LONG REACH

(1) 8.2 m (26' 11") boom, 6.3 m (20' 8") arm equipped with 0.52 m³ (0.68yd³)(SAE heaped) bucket, 800 mm (32") triple grouser shoe and 5300 kg counterweight.

- : Rating over-front
- : Rating over-side or 360 degree

Load point height		Load radius														At max. reach			
		4.5 m (15.0 ft)		6.0 m (20.0ft)		7.5 m (25.0 ft)		9.0 m (30.0 ft)		10.5 m (35.0 ft)		12.0 m (40.0 ft)		13.5 m (45.0 ft)		Capacity		Reach	
																		m (ft)	
10.5 m	kg																*1480	*1480	12.11
35.0 ft	lb																*3260	*3260	(39.7)
9.0 m	kg																*1510	*1510	13.11
30.0 ft	lb																*3330	*3330	(43.0)
7.5 m	kg																*1550	1320	13.84
25.0 ft	lb																*3420	2910	(45.4)
6.0 m	kg																*1600	1160	14.37
20.0 ft	lb																*3530	2560	(47.1)
4.5 m	kg																*1660	1050	14.72
15.0 ft	lb																*3660	2310	(48.3)
3.0 m	kg																*1720	980	14.89
10.0 ft	lb																*3790	2160	(48.9)
1.5 m	kg	*5620	*5620	*3940	*3940	*3090	*3090	*2590	*2590	*2270	2000	*2050	1530	*1790	1170	*1800	940	14.90	
5.0 ft	lb	*12390	*12390	*8690	*8690	*6810	*6810	*5710	*5710	*5000	4410	*4520	3370	*3950	2580	*3970	2070	(48.9)	
Ground /line	kg	*6990	6720	*4770	4490	*3620	3240	*2950	2430	*2510	1860	*2220	1440	*1820	1110	1880	930	14.75	
	lb	*15410	14820	*10520	9900	*7980	7140	*6500	5360	*5530	4100	*4890	3170	*4010	2450	4140	2050	(48.4)	
-1.5 m	kg	*7830	6210	*5390	4120	*4060	2990	*3260	2260	*2740	1740	*2380	1360	*1570	1070	1930	960	14.42	
-5.0 ft	lb	*17260	13690	*11880	9080	*8950	6590	*7190	4980	*6040	3840	*5250	3000	*3460	2360	4250	2120	(47.3)	
-3.0 m	kg	*8230	5990	*5780	3920	*4370	2830	*3490	2140	*2900	1660	*2490	1310			2030	1020	13.92	
-10.0 ft	lb	*18140	13210	*12740	8640	*9630	6240	*7690	4720	*6390	3660	*5490	2890			4480	2250	(45.7)	
-4.5 m	kg	*8310	5940	*5950	3830	*4540	2740	*3630	2070	*3000	1620	2510	1290			*2210	1140	13.20	
-15.0 ft	lb	*18320	13100	*13120	8440	*10010	6040	*8000	4560	*6610	3570	5530	2840			*4870	2510	(43.3)	
-6.0 m	kg	*8100	6010	*5900	3840	*4550	2730	*3640	2060	*2970	1620					*2340	1330	12.25	
-20.0 ft	lb	*17860	13250	*13010	8470	*10030	6020	*8020	4540	*6550	3570					*5160	2930	(40.2)	
-7.5 m	kg	*7580	6180	*5610	3930	*4350	2790	*3460	2120	*2740	1690					*2460	1670	10.97	
-25.0 ft	lb	*16710	13620	*12370	8660	*9590	6150	*7630	4670	*6040	3730					*5420	3680	(36.0)	
-9.0 m	kg	*6650	6460	*4980	4110	*3840	2940	*2930	2260										
-30.0 ft	lb	*14660	14240	*10980	9060	*8470	6480	*6460	4980										
-10.5 m	kg	*5040	*5040	*3730	*3730														
-35.0 ft	lb	*11110	*11110	*8220	*8220														

- Note
1. Lifting capacity are based on SAE J1097 and ISO 10567.
 2. Lifting capacity of the ROBEX series does not exceed 75% of tipping load with the machine on firm, level ground or 87% of full hydraulic capacity.
 3. The load point is a hook located on the back of the bucket.
 4. *indicates load limited by hydraulic capacity.



3) R210LC-9 HIGH WALKER

(1) 5.68 m (18' 8") boom, 2.0 m (6' 7") arm equipped with 0.92 m³ (SAE heaped) bucket, 600 mm (24") triple grouser shoe and 3800 kg counterweight.

- : Rating over-front
- : Rating over-side or 360 degree

Load point height		Load radius								At max. reach		
		3.0 m (10 ft)		4.5 m (15 ft)		6.0 m (20 ft)		7.5 m (25.0 ft)		Capacity		Reach
												m (ft)
7.5 m (25 ft)	kg lb									*4010 *8840	*4010 *8840	6.82 (22.4)
6.0 m (20 ft)	kg lb					*4460 *9830	*4460 *9830			*4080 *8990	3800 8380	7.88 (25.9)
4.5 m (15 ft)	kg lb	*8630 *19030	*8630 *19030	*5930 *13070	*5930 *13070	*4940 *10890	*4940 *10890			*4210 *9280	3260 7190	8.49 (27.9)
-3.0 m (-10 ft)	kg lb			*7690 *16950	*7690 *16950	*5720 *12610	5600 12350	*4870 *10740	3890 8580	4310 9500	3030 6680	8.75 (28.7)
-1.5 m (-5 ft)	kg lb			*9130 *20130	8310 18320	*6470 *14260	5350 11790	*5220 *11510	3780 8330	4290 9460	3000 6610	8.71 (28.6)
Ground Line	kg lb			*9720 *21430	8100 17860	*6950 *15320	5190 11440	5320 11730	3710 8180	4560 10050	3190 7030	8.36 (27.4)
-1.5 m (-5 ft)	kg lb	*13860 *30560	*13860 *30560	*9570 *21100	8090 17840	*6960 *15340	5160 11380			*4900 *10800	3700 8160	7.64 (25.1)
-3.0 m (-10 ft)	kg lb	*12230 *26960	*12230 *26960	*8650 *19070	8240 18170					*4800 *10580	*4800 *10580	6.42 (21.1)

- Note
1. Lifting capacity are based on SAE J1097 and ISO 10567.
 2. Lifting capacity of the ROBEX series does not exceed 75% of tipping load with the machine on firm, level ground or 87% of full hydraulic capacity.
 3. The load point is a hook located on the back of the bucket.
 4. *indicates load limited by hydraulic capacity.



(2) 5.68 m (18' 8") boom, 2.4 m (7' 10") arm equipped with 0.92 m³ (SAE heaped) bucket, 600 mm (24") triple grouser shoe and 3800 kg counterweight.

Load point height		Load radius										At max. reach					
		1.5 m (5 ft)		3.0 m (10 ft)		4.5 m (15 ft)		6.0 m (20 ft)		7.5 m (25 ft)		Capacity		Reach			
														m (ft)			
7.5 m (25 ft)	kg lb														*3700 *8160	*3700 *8160	7.31 (24.0)
6.0 m (20 ft)	kg lb							*4050 *8930	*4050 *8930					*3790 *8360	3480 7670	8.30 (27.2)	
4.5 m (15 ft)	kg lb					*5360 *11820	*5360 *11820	*4580 *10100	*4580 *10100	*4260 *9390	4030 8880			*3920 *8640	3020 6660	8.87 (29.1)	
3.0 m (10 ft)	kg lb					*7130 *15720	*7130 *15720	*5390 *11880	*5390 *11880	*4610 *10160	3900 8600			4010 8840	2810 6190	9.12 (29.9)	
1.5 m (5 ft)	kg lb					*8720 *19220	8370 18450	*6220 *13710	5360 11820	*5020 *11070	3770 8310			3990 8800	2780 6130	9.08 (29.8)	
Ground Line	kg lb			*9350 *20610	*9350 *20610	*9550 *21050	8080 17810	*6790 *14970	5170 11400	5290 11660	3670 8090			4210 9280	2940 6480	8.75 (28.7)	
-1.5 m (-5 ft)	kg lb	*10290 *22690	*10290 *22690	*14180 *31260	*14180 *31260	*9620 *21210	8020 17680	*6950 *15320	5100 11240					*4650 *10250	3360 7410	8.07 (26.5)	
-3.0 m (-10 ft)	kg lb	*14760 *32540	*14760 *32540	*12990 *28640	*12990 *28640	*8950 *19730	8120 17900	*6470 *14260	5170 11400					*4690 *10340	4350 9590	6.94 (22.8)	
-4.5 m (-15 ft)	kg lb			*10150 *22380	*10150 *22380	*7020 *15480	*7020 *15480										

(3) 5.68 m (18' 8") boom, 2.92 m (9' 7") arm equipped with 0.92 m³ (SAE heaped) bucket, 600 mm (24") triple grouser shoe and 3800 kg counterweight.

Load point height		Load radius										At max. reach					
		1.5 m (5 ft)		3.0 m (10 ft)		4.5 m (15 ft)		6.0 m (20 ft)		7.5 m (25 ft)		Capacity		Reach			
														m (ft)			
7.5 m (25 ft)	kg lb														*3370 *7430	*3370 *7430	7.93 (26.0)
6.0 m (20 ft)	kg lb									*2700 *5950	*2700 *5950			*3460 *7630	3130 6900	8.83 (29.0)	
4.5 m (15 ft)	kg lb							*1110 *9060	*4110 *9060	*3870 *8530	*3870 *8530			*3600 *7940	2740 6040	9.37 (30.7)	
3.0 m (10 ft)	kg lb			*10440 *23020	*10440 *23020	*6400 *14110	*6400 *14110	*4960 *10930	*4960 *10930	*4290 *9460	3930 8660			3680 8110	2560 5640	9.60 (31.5)	
1.5 m (5 ft)	kg lb			*8610 *18980	*8610 *18980	*8150 *17970	*8150 *17970	*5860 *12920	5380 11860	*4760 *10490	3770 8310			3650 8050	2530 5580	9.57 (31.4)	
Ground Line	kg lb			*9870 *21760	*9870 *21760	*9260 *20410	8080 17810	*6560 *14460	5150 11350	*5150 *11350	3640 8020			3820 8420	2650 5840	9.25 (30.3)	
-1.5 m (-5 ft)	kg lb	*9210 *20300	*9210 *20300	*13090 *28860	*13090 *28860	*9600 *21160	7940 17500	*6880 *15170	5040 11110	5200 11460	3590 7910			4280 9440	2980 6570	8.62 (28.3)	
-3.0 m (-10 ft)	kg lb	*12660 *27910	*12660 *27910	*13780 *30380	*13780 *30380	*9230 *20350	7990 17610	*6670 *14700	5060 11160					*4470 *9850	3710 8180	7.59 (24.9)	
-4.5 m (-15 ft)	kg lb			*11470 *25290	*11470 *25290	*7860 *17330	*7860 *17330							*4250 *9370	*4250 *9370	5.89 (19.3)	



(4) 5.68 m (18' 8") boom, 3.9 m (12' 10") arm equipped with 0.92 m³ (SAE heaped) bucket, 600 mm (24") triple grouser shoe and 3800 kg counterweight.

Load point height		Load radius												At max. reach						
		1.5 m (5 ft)		3.0 m (10 ft)		4.5 m (15 ft)		6.0 m (20 ft)		7.5 m (25 ft)		9.0 m (30 ft)		Capacity		Reach				
																m (ft)				
9.0 m (30 ft)	kg lb																*2750 *6060	*2750 *6060	7.86 (25.8)	
7.5 m (25 ft)	kg lb									*2220 *4890	*2220 *4890						*2810 *6190	*2810 *6190	9.06 (29.7)	
6.0 m (20 ft)	kg lb									*2850 *6280	*2850 *6280						*2910 *6420	2550 5620	9.85 (32.3)	
4.5 m (15 ft)	kg lb									*3140 *6920	*3140 *6920	*2180 *4810	*2180 *4810				*3030 *6680	2270 5000	10.33 (33.9)	
3.0 m (10 ft)	kg lb							*4060 *8950	*4060 *8950	*3620 *7980	*3620 *7980	*2990 *6590	2840 6260				3100 6830	2120 4670	10.54 (34.6)	
1.5 m (5 ft)	kg lb			*11630 *25640	*11630 *25640	*6880 *15170	*6880 *15170	*5070 *11180	*5070 *11180	*4190 *9240	3770 8310	*3490 *7690	2730 6020				3070 6770	2090 4610	10.50 (34.4)	
Ground Line	kg lb	*5540 *12210	*5540 *12210	*10590 *23350	*10590 *23350	*8400 *18520	8100 17860	*5960 *13140	5130 11310	*4710 *10380	3590 7910	*3480 *7670	2640 5820				3180 7010	2160 4760	10.22 (33.5)	
-1.5 m (-5 ft)	kg lb	*7800 *17200	*7800 *17200	*11920 *26280	*11920 *26280	*9220 *20330	7800 17200	*6540 *14420	4940 10890	*5060 *11160	3480 7670						3480 7670	2370 5220	9.67 (31.7)	
-3.0 m (-10 ft)	kg lb	*10330 *22770	*10330 *22770	*14530 *32030	*14530 *32030	*9340 *20590	7730 17040	*6690 *14750	4870 10740	5060 11160	3450 7610						*3920 *8640	2820 6220	8.78 (28.8)	
-4.5 m (-15 ft)	kg lb	*13390 *29520	*13390 *29520	*13120 *28920	*13120 *28920	*8690 *19160	7840 17280	*6230 *13730	4940 10890								*4030 *8880	3800 8380	7.41 (24.3)	
-6.0 m (-20 ft)	kg lb			*10090 *22240	*10090 *22240	*6720 *14820	*6720 *14820													



6. BUCKET SELECTION GUIDE

1) GENERAL BUCKET

0.51 m ³ SAE heaped bucket	0.80 m ³ SAE heaped bucket	0.92 m ³ SAE heaped bucket	1.10 m ³ SAE heaped bucket	1.20 m ³ SAE heaped bucket	1.34 m ³ SAE heaped bucket

Capacity		Width		Weight	Recommendation			
SAE heaped	CECE heaped	Without side cutter	With side cutter		5.68 m (18' 8") boom			
					2.0 m arm (6' 7")	2.4 m arm (7' 10")	2.92 m arm (9' 7")	3.90 m arm (12' 10")
0.51 m ³ (0.67 yd ³)	0.45 m ³ (0.59 yd ³)	700 mm (27.6")	820 mm (32.3")	570 kg (1260 lb)				
0.80 m ³ (1.05 yd ³)	0.70 m ³ (0.92 yd ³)	1000 mm (39.4")	1120 mm (44.1")	700 kg (1540 lb)				
0.92 m ³ (1.20 yd ³)	0.80 m ³ (1.05 yd ³)	1150 mm (45.3")	1270 mm (50.0")	770 kg (1700 lb)				
1.10 m ³ (1.44 yd ³)	0.96 m ³ (1.26 yd ³)	1320 mm (52.0")	1440 mm (56.7")	830 kg (1830 lb)				
1.20 m ³ (1.57 yd ³)	1.00 m ³ (1.31 yd ³)	1400 mm (55.1")	1520 mm (59.8")	850 kg (1870 lb)				
1.34 m ³ (1.75 yd ³)	1.15 m ³ (1.50 yd ³)	1550 mm (61.0")	1670 mm (65.7")	920 kg (2030 lb)				



Applicable for materials with density of 2000 kg/m³ (3370 lbf/yd³) or less

Applicable for materials with density of 1600 kg/m³ (2700 lbf/yd³) or less

Applicable for materials with density of 1100 kg/m³ (1850 lbf/yd³) or less

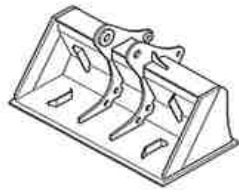

2) HEAVY DUTY, ROCK AND SLOPE FINISHING BUCKET

		
◆ 0.74, 0.90, 1.05 m ³ SAE heaped bucket	⊙ 0.87, 1.20 m ³ SAE heaped bucket	■ 0.75 m ³ SAE heaped bucket

Capacity		Width		Weight	Recommendation			
					5.68 m (18' 8") boom			
SAE heaped	CECE heaped	Without side cutter	With side cutter		2.0 m arm (6' 7")	2.4 m arm (7' 10")	2.92 m arm (9' 7")	3.90 m arm (12' 10")
◆0.74 m ³ (0.97 yd ³)	0.65 m ³ (0.85 yd ³)	985 mm (38.8")	-	770 kg (1700 lb)				
◆0.90 m ³ (1.18 yd ³)	0.80 m ³ (1.05 yd ³)	1070 mm (42.0")	-	810 kg (1790 lb)				
◆1.05 m ³ (1.37 yd ³)	0.92 m ³ (1.20 yd ³)	1290 mm (50.8")	-	890 kg (1960 lb)				
⊙0.87 m ³ (1.14 yd ³)	0.75 m ³ (0.98 yd ³)	1140 mm (44.9")	-	900 kg (1980 lb)				
⊙1.20 m ³ (1.57 yd ³)	1.00 m ³ (1.31 yd ³)	1410 mm (55.5")	-	1030 kg (2270 lb)				
■0.75 m ³ (0.98 yd ³)	0.65 m ³ (0.85 yd ³)	1790 mm (70.5")	-	880 kg (1940 lb)				

◆ : Heavy duty bucket ⊙ : Rock bucket (heavy) ■ : Slope finishing bucket

- Applicable for materials with density of 2000 kgf/m³ (3370 lbf/yd³) or less
- Applicable for materials with density of 1600 kgf/m³ (2700 lbf/yd³) or less
- Applicable for materials with density of 1100 kgf/m³ (1850 lbf/yd³) or less



7. UNDERCARRIAGE

1) TRACKS

X-leg type center frame is integrally welded with reinforced box-section track frames. The design includes dry tracks, lubricated rollers, idlers, sprockets, hydraulic track adjusters with shock absorbing springs and assembled track-type tractor shoes with triple grousers.

2) TYPES OF SHOES

Model	Shapes		Triple grouser			
						
R210LC-9	Shoe width	mm (in)	600 (24)	700 (28)	800 (32)	900 (36)
	Operating weight	kg (lb)	21900 (48280)	22250 (49050)	22515 (49640)	22780 (50220)
	Ground pressure	kgf/cm ² (psi)	0.46 (6.54)	0.40 (5.69)	0.36 (5.12)	0.32 (4.55)
	Overall width	mm (ft-in)	2990 (9' 10")	3090 (10' 2")	3190 (10' 6")	3290 (10' 10")
R210LC-9 LONG REACH	Shoe width	mm (in)	-	-	800 (32)	-
	Operating weight	kg (lb)	-	-	24360 (53700)	-
	Ground pressure	kgf/cm ² (psi)	-	-	0.42 (5.97)	-
	Overall width	mm (ft-in)	-	-	3190 (10' 6")	-
R210LC-9 HIGH WALKER	Shoe width	mm (in)	600 (24)	700 (28)	800 (32)	710 (28)*
	Operating weight	kg (lb)	23160 (51060)	23710 (52270)	23975 (52860)	24135 (53210)
	Ground pressure	kgf/cm ² (psi)	0.49 (6.97)	0.43 (6.12)	0.38 (5.40)	0.43 (6.12)
	Overall width	mm (ft-in)	3395 (11' 2")	3495 (11' 6")	3595 (11' 10")	3505 (11' 6")

* : Double grouser

3) NUMBER OF ROLLERS AND SHOES ON EACH SIDE

Item	Quantity
Carrier rollers	2 EA
Track rollers	9 EA
Track shoes	49 EA



4) SELECTION OF TRACK SHOE

Suitable track shoes should be selected according to operating conditions.

Method of selecting shoes

Confirm the category from the list of applications in table 2, then use table 1 to select the shoe. Wide shoes (categories B and C) have limitations on applications. Before using wide shoes, check the precautions, then investigate and study the operating conditions to confirm if these shoes are suitable.

Select the narrowest shoe possible to meet the required flotation and ground pressure. Application of wider shoes than recommendations will cause unexpected problem such as bending of shoes, crack of link, breakage of pin, loosening of shoe bolts and the other various problems.

※ Table 1

Track shoe	Specification	Category
600 mm triple grouser	Standard	A
700 mm triple grouser	Option	B
800 mm triple grouser	Option	C
800 mm triple grouser (long reach)	Standard	C
900 mm triple grouser	Option	C

※ Table 2

Category	Applications	Precautions
A	Rocky ground, river beds, normal soil	<ul style="list-style-type: none"> Travel at low speed on rough ground with large obstacles such as boulders or fallen trees
B	Normal soil, soft ground	<ul style="list-style-type: none"> These shoes cannot be used on rough ground with large obstacles such as boulders or fallen trees Travel at high speed only on flat ground Travel slowly at low speed if it is impossible to avoid going over obstacles
C	Extremely soft ground (swampy ground)	<ul style="list-style-type: none"> Use the shoes only in the conditions that the machine sinks and it is impossible to use the shoes of category A or B These shoes cannot be used on rough ground with large obstacles such as boulders or fallen trees Travel at high speed only on flat ground Travel slowly at low speed if it is impossible to avoid going over obstacles



8. SPECIFICATIONS FOR MAJOR COMPONENTS

1) ENGINE

Item	Specification
Model	Cummins QSB6.7
Type	4-cycle turbocharged diesel engine, low emission
Cooling method	Water cooling
Number of cylinders and arrangement	6 cylinders, in-line
Firing order	1-5-3-6-2-4
Combustion chamber type	Direct injection type
Cylinder bore × stroke	107 × 124 mm (4.2" × 4.9")
Piston displacement	6700 cc (409cu in)
Compression ratio	17.2 : 1
Rated gross horse power (SAE J1995)	151 Hp at 1900 rpm (113 kW at 1900 rpm)
Maximum torque at 1500 rpm	63.0 kgf · m (456 lbf · ft)
Engine oil quantity	24 l (6.3 U.S. gal)
Dry weight	556 kg (1226 lb)
High idling speed	1950 ± 50 rpm
Low idling speed	850 ± 100 rpm
Rated fuel consumption	163.2 g/Hp · hr at 1900 rpm
Starting motor	Nippon denso (24 V-4.5 kW)
Alternator	Delco Remy (24 V-50 A)
Battery	2 × 12 V × 100 Ah

2) MAIN PUMP

Item	Specification
Type	Variable displacement tandem axis piston pumps
Capacity	2 × 117cc/rev
Maximum pressure	350kgf/cm ² (4980psi) [380 kgf/cm ² (5400 psi)]
Rated oil flow	2 × 222 l /min (58.6U.S. gpm/ 48.8U.K. gpm)
Rated speed	1900 rpm

[] : Power boost



3) GEAR PUMP

Item	Specification
Type	Fixed displacement gear pump single stage
Capacity	15 cc/rev
Maximum pressure	40 kgf/cm ² (570 psi)
Rated oil flow	28.5 l /min (7.5 U.S. gpm/6.3 U.K. gpm)

4) MAIN CONTROL VALVE

Item	Specification
Type	9 spools two-block
Operating method	Hydraulic pilot system
Main relief valve pressure	350 kgf/cm ² (4980 psi) [380 kgf/cm ² (5400 psi)]
Overload relief valve pressure	400 kgf/cm ² (5690 psi)

[]: Power boost

5) SWING MOTOR

Item	Specification
Type	Two fixed displacement axial piston motor
Capacity	151 cc/rev
Relief pressure	265 kgf/cm ² (3770 psi)
Braking system	Automatic, spring applied hydraulic released
Braking torque	59 kgf · m (427 lbf · ft)
Brake release pressure	33~50 kgf/cm ² (470~711 psi)
Reduction gear type	2 - stage planetary

6) TRAVEL MOTOR

Item	Specification
Type	Variable displacement axial piston motor
Relief pressure	350 kgf/cm ² (4980 psi)
Reduction gear type	2-stage planetary
Braking system	Automatic, spring applied hydraulic released
Brake release pressure	11 kgf/cm ² (156 psi)
Braking torque	49.3 kgf · m (357 lbf · ft)



7) REMOTE CONTROL VALVE

Item		Specification
Type		Pressure reducing type
Operating pressure	Minimum	6.5 kgf/cm ² (92 psi)
	Maximum	25 kgf/cm ² (356 psi)
Single operation stroke	Lever	61 mm (2.4 in)
	Pedal	123 mm (4.84 in)

8) CYLINDER

Item		Specification
Boom cylinder	Bore dia × Rod dia × Stroke	∅ 120 × ∅ 85 × 1290 mm
	Cushion	Extend only
Arm cylinder	Bore dia × Rod dia × Stroke	∅ 140 × ∅ 100 × 1510 mm # ∅ 140 × ∅ 95 × 1460 mm
	Cushion	Extend and retract
Bucket cylinder	Bore dia × Rod dia × Stroke	∅ 120 × ∅ 85 × 1055 mm # ∅ 100 × ∅ 70 × 870 mm
	Cushion	Extend only

* Discoloration of cylinder rod can occur when the friction reduction additive of lubrication oil spreads on the rod surface.

* Discoloration does not cause any harmful effect on the cylinder performance.

: LONG REACH

9) SHOE

Item		Width	Ground pressure	Link quantity	Overall width
R210LC-9	Standard	600 mm (24")	0.46 kgf/cm ² (6.54 psi)	49	2990 mm (9' 10")
	Option	700 mm (28")	0.40 kgf/cm ² (5.69 psi)	49	3090 mm (10' 2")
		800 mm (32")	0.36 kgf/cm ² (5.12 psi)	49	3190 mm (10' 6")
		900 mm (36")	0.32 kgf/cm ² (4.55 psi)	49	3290 mm (10' 10")
R210LC-9 LONG REACH	Standard	800 mm (32")	0.39 kgf/cm ² (5.55 psi)	49	3190 mm (10' 6")
R210LC-9 HIGH WALKER	Standard	600 mm (24")	0.50 kgf/cm ² (7.11 psi)	49	3395 mm (11' 2")
	Option	700 mm (28")	0.43 kgf/cm ² (6.12 psi)	49	3495 mm (11' 6")
		800 mm (32")	0.38 kgf/cm ² (5.40 psi)	49	3595 mm (11' 10")
		* 710 mm (28")	0.43 kgf/cm ² (6.12 psi)	49	3505 mm (11' 6")

* : Double grouser



10) BUCKET

Item	Capacity		Tooth quantity	Width	
	SAE heaped	CECE heaped		Without side cutter	With side cutter
R210LC-9	0.51 m ³ (0.67 yd ³)	0.45 m ³ (0.59 yd ³)	3	700 mm (27.6")	820 mm (32.3")
	0.80 m ³ (1.05 yd ³)	0.70 m ³ (0.92 yd ³)	5	1000 mm (39.4")	1120 mm (44.1")
	0.92 m ³ (1.20 yd ³)	0.80 m ³ (1.05 yd ³)	5	1150 mm (45.3")	1270 mm (50.0")
	1.10 m ³ (1.44 yd ³)	0.96 m ³ (1.26 yd ³)	5	1320 mm (52.0")	1440 mm (56.7")
	1.20 m ³ (1.57 yd ³)	1.00 m ³ (1.31 yd ³)	5	1400 mm (55.1")	1520 mm (59.8")
	1.34 m ³ (1.75 yd ³)	1.15 m ³ (1.50 yd ³)	6	1550 mm (61.0")	1670 mm (65.7")
	◆0.74 m ³ (0.97 yd ³)	0.65 m ³ (0.85 yd ³)	5	985 mm (38.8")	-
	◆0.90 m ³ (1.18 yd ³)	0.80 m ³ (1.05 yd ³)	5	1070 mm (42.0")	-
	◆1.05 m ³ (1.37 yd ³)	0.92 m ³ (1.20 yd ³)	5	1290 mm (50.8")	-
	⊙0.87 m ³ (1.14 yd ³)	0.75 m ³ (0.98 yd ³)	5	1140 mm (44.9")	-
	⊙1.20 m ³ (1.57 yd ³)	1.00 m ³ (1.31 yd ³)	5	1410 mm (55.5")	-
	■0.75 m ³ (0.98 yd ³)	0.65 m ³ (0.85 yd ³)	-	1790 mm (70.5")	-

- ◆ : Heavy duty bucket
- ⊙ : Rock bucket (heavy)
- : Slope finishing bucket



9. RECOMMENDED OILS

Use only oils listed below or equivalent.
Do not mix different brand oil.

Service point	Kind of fluid	Capacity l (U.S. gal)	Ambient temperature °C (°F)								
			-20 (-4)	-10 (14)	0 (32)	10 (50)	20 (68)	30 (86)	40 (104)		
Engine oil pan	Engine oil	24 (6.3)				SAE 30					
			SAE 10W								
			SAE 10W-30								
						SAE 15W-40					
Swing drive	Gear oil	5.0 (1.3)				SAE 85W-140					
Final drive		5.8 × 2 (1.5 × 2)									
Hydraulic tank	Hydraulic oil	Tank; 160 (42) System; 275 (73)	ISO VG 32								
			ISO VG 46								
						ISO VG 68					
Fuel tank	Diesel fuel	400 (106)	ASTM D975 NO.1								
							ASTM D975 NO.2				
Fitting (grease nipple)	Grease	As required	NLGI NO.1								
							NLGI NO.2				
Radiator (reservoir tank)	Mixture of antifreeze and water 50 : 50	35 (9.2)	Ethylene glycol base permanent type								

- SAE : Society of Automotive Engineers
- API : American Petroleum Institute
- ISO : International Organization for Standardization
- NLGI : National Lubricating Grease Institute
- ASTM : American Society of Testing and Material

CONTROL DEVICES

1. CAB DEVICES

1) The ergonomically designed console box and suspension type seat provide the operator with comfort.

2) ELECTRONIC MONITOR SYSTEM

(1) The centralized electronic monitor system allows the status and conditions of the machine to be monitored at a glance.

(2) It is equipped with a safety warning system for early detection of machine malfunction.

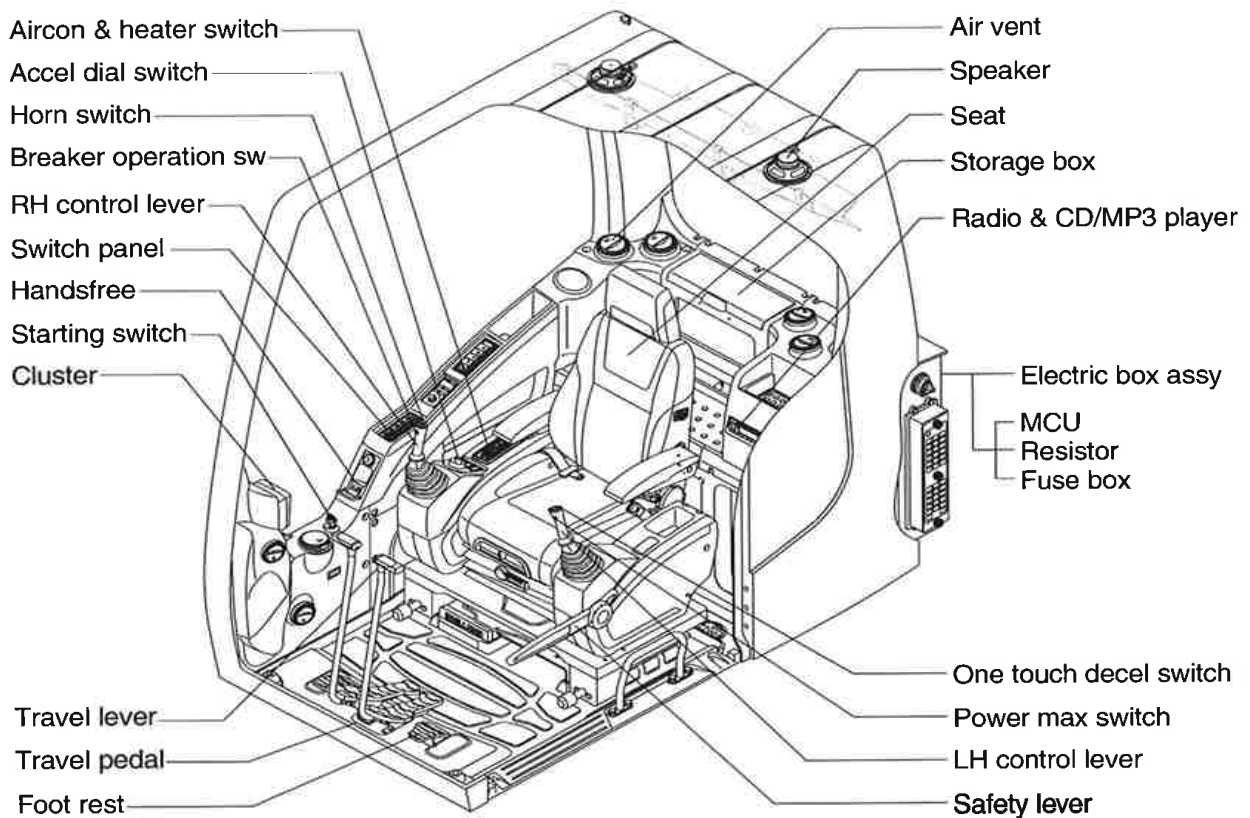

21093CD01

2. CLUSTER

1) STRUCTURE

The cluster consists of LCD and switches as shown below. The LCD is to warn the operator in case of abnormal machine operation or conditions for the appropriate operation and inspection. Also, The LCD is to set and display for modes, monitoring and utilities with the switches.

The switches are to set the machine operation modes.

- ※ The cluster installed on this machine does not entirely guarantee the condition of the machine. Daily inspection should be performed according to chapter 6, Maintenance.
- ※ When the cluster provides a warning immediately check the problem, and perform the required action.

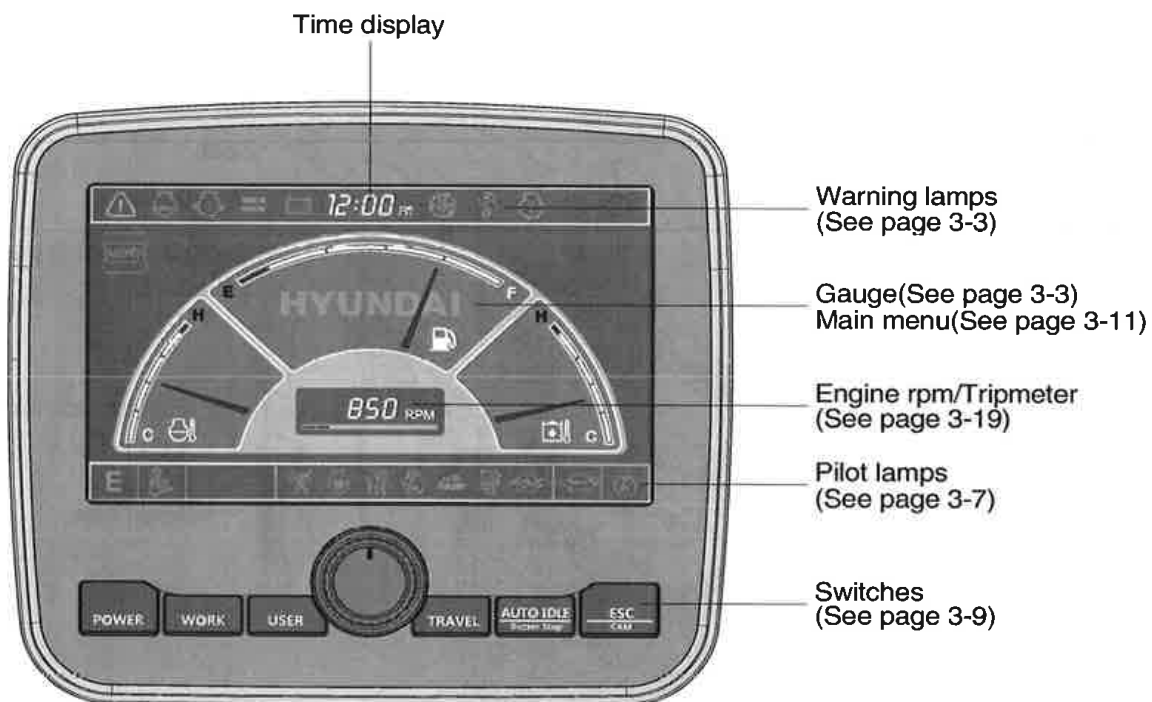

21093CD07

- ※ The warning lamp pops up and/or blinks and the buzzer sounds when the machine has a problem.
The warning lamp blinks until the problem is cleared. Refer to page 3-4 for details.

2) GAUGE

(1) Operation screen





※ Operation screen type can be set by the screen type menu of the display.
Refer to page 3-21 for details.

(2) Engine coolant temperature gauge





21093CD07G

- ① This gauge indicates the temperature of coolant.
 - White range : 40-105°C (104-221°F)
 - Red range : Above 105°C (221°F)
 - ② If the indicator is in the red range or  lamp blinks in red, turn OFF the engine and check the engine cooling system.
- ※ If the gauge indicates the red range or  lamp blinks in red even though the machine is on the normal condition, check the electric device as that can be caused by the poor connection of electricity or sensor.

(3) Hydraulic oil temperature gauge





21093CD07E

- ① This gauge indicates the temperature of hydraulic oil.
 - White range : 40-105°C(104-221°F)
 - Red range : Above 105°C(221°F)
 - ② If the indicator is in the red range or  lamp blinks is red, reduce the load on the system. If the gauge stays in the red range, stop the machine and check the cause of the problem.
- ※ If the gauge indicates the red range or  lamp blinks in red even though the machine is on the normal condition, check the electric device as that can be caused by the poor connection of electricity or sensor.

(4) Fuel level gauge



21093CD07F

- ① This gauge indicates the amount of fuel in the fuel tank.
 - ② Fill the fuel when the red range, or  lamp blinks in red.
- ※ If the gauge indicates the red range or  lamp blinks in red even though the machine is on the normal condition, check the electric device as that can be caused by the poor connection of electricity or sensor.

(5) RPM / Tripmeter display



21093CD02D

- ① This displays the engine rpm or the tripmeter.
- ※ Refer to page 3-19 for details.

3) WARNING LAMPS



21093CD08D

- ※ Each warning lamp on the top of the LCD pops up on the center of LCD and the buzzer sounds when the each warning is happened. The pop-up warning lamp moves to the original position and blinks when the select switch is pushed. And the buzzer stops. Refer to page 3-10 for the select switch.

(1) Engine coolant temperature



21093CD08A

- ① Engine coolant temperature warning is indicated two steps.
 - 100°C over : The lamp blinks and the buzzer sounds.
 - 105°C over : The lamp pops up on the center of LCD and the buzzer sounds.
- ② The pop-up lamp moves to the original position and blinks when the select switch is pushed. Also, the buzzer stops and lamp keeps blink.
- ③ Check the cooling system when the lamp keeps ON.

(2) Hydraulic oil temperature



21093CD08C

- ① Hydraulic oil temperature warning is indicated two steps.
 - 100°C over : The lamp blinks and the buzzer sounds.
 - 105°C over : The lamp pops up on the center of LCD and the buzzer sounds.
- ② The pop-up lamp moves to the original position and blinks when the select switch is pushed. Also, the buzzer stops and lamp keeps blink.
- ③ Check the hydraulic oil level and hydraulic oil cooling system.

(3) Fuel level



21093CD08B

- ① This warning lamp blinks and the buzzer sounds when the level of fuel is below 55 l (14.53 U.S. gal).
- ② Fill the fuel immediately when the lamp blinks.

(4) Emergency warning lamp



21093CD30

- ① This lamp pops up and the buzzer sounds when each of the below warnings is happened.
 - Engine coolant overheating (over 105°C)
 - Hydraulic oil overheating (over 105°C)
 - Pump EPPR circuit abnormal or open
 - Attachment flow EPPR circuit abnormal or open
 - MCU input voltage abnormal
 - Accel dial circuit abnormal or open
 - Cluster communication data error
 - Engine ECM communication data error
- ※ The pop-up warning lamp moves to the original position and blinks when the select switch is pushed. Also the buzzer stops. This is same as following warning lamps.
- ② When this warning lamp blinks, machine must be checked and serviced immediately.

(5) Engine oil pressure warning lamp

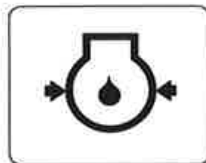

21093CD32

- ① This lamp blinks when the engine oil pressure is low.
- ② If the lamp blinks, shut OFF the engine immediately. Check oil level.

(6) Check engine warning lamp



21093CD33

- ① This lamp blinks when the communication between MCU and engine ECM on the engine is abnormal, or if the cluster received any fault code from engine ECM.
- ② Check the communication line between them.
If the communication line is OK, then check the fault codes on the cluster.

(7) Battery charging warning lamp

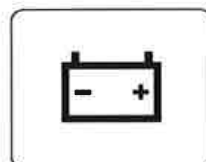

21093CD34

- ① This lamp blinks when the battery charging voltage is low.
- ② Check the battery charging circuit when this lamp blinks.



(8) Air cleaner warning lamp



21093CD35

- ① This lamp blinks when the filter of air cleaner is clogged.
- ② Check the filter and clean or replace it.

(9) Overload warning lamp (opt)

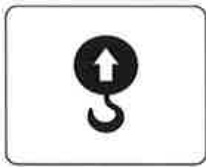

21093CD36

- ① When the machine is overload, the overload warning lamp blinks during the overload switch is ON. (if equipped)
- ② Reduce the machine load.

4) PILOT LAMPS



21093CD09

(1) Mode pilot lamps

No	Mode	Pilot lamp	Selected mode
1	Power mode		Heavy duty power work mode
			Standard power mode
			Economy power mode
2	User mode		User preferable power mode
3	Work mode		General operation mode
			Breaker operation mode
			Crusher operation mode
4	Travel mode		Low speed traveling
			High speed traveling
5	Auto idle mode		Auto idle
6	Work tool mode		Oil flow level of breaker or crusher mode
7	Message display		"Setting is completed" display after selection

(2) Power max pilot lamp



21093CD38

- ① The lamp will be ON when pushing power max switch on the LH RCV lever.
 - ② The power max function is operated maximum 8 seconds.
- ※ Refer to the page 3-26 for power max function.

(3) Preheat pilot lamp

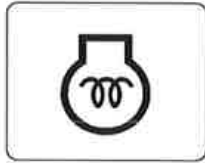

21093CD39

- ① Turning the start key switch ON position starts preheating in cold weather.
- ② Start the engine after this lamp is OFF.

(4) Warming up pilot lamp

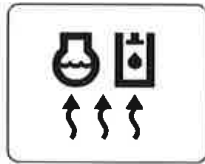

21093CD40

- ① This lamp is turned ON when the coolant temperature is below 30°C (86°F).
- ② The automatic warming up is cancelled when the engine coolant temperature is above 30°C, or when 10 minutes have passed since starting the engine.

(5) Decel pilot lamp

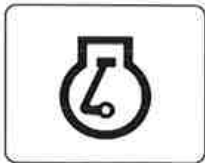

21093CD41

- ① Operating one touch decel switch on the RCV lever makes the lamp ON.
 - ② Also, the lamp will be ON and engine speed will be lowered automatically to save fuel consumption when all levers and pedals are at neutral position, and the auto idle function is selected.
- ※ One touch decel is not available when the auto idle pilot lamp is turned ON.
- ※ Refer to the page 3-26.

(6) Fuel warmer pilot lamp



21093CD43

- ① This lamp is turned ON when the coolant temperature is below 10°C (50°F).
- ② The automatic fuel warming is cancelled when the engine coolant temperature is above 60°C, or when 30 minutes have passed since the start switch was ON position.

(7) Maintenance pilot lamp



21093CD44

- ① This lamp will be ON when the consuming parts are needed to change or replace. It means that the change or replacement interval of the consuming parts remains below 30 hours.
- ② Check the message in maintenance information of main menu. Also, this lamp lights ON for 3 minutes when the start switch is ON position.

5) SWITCHES

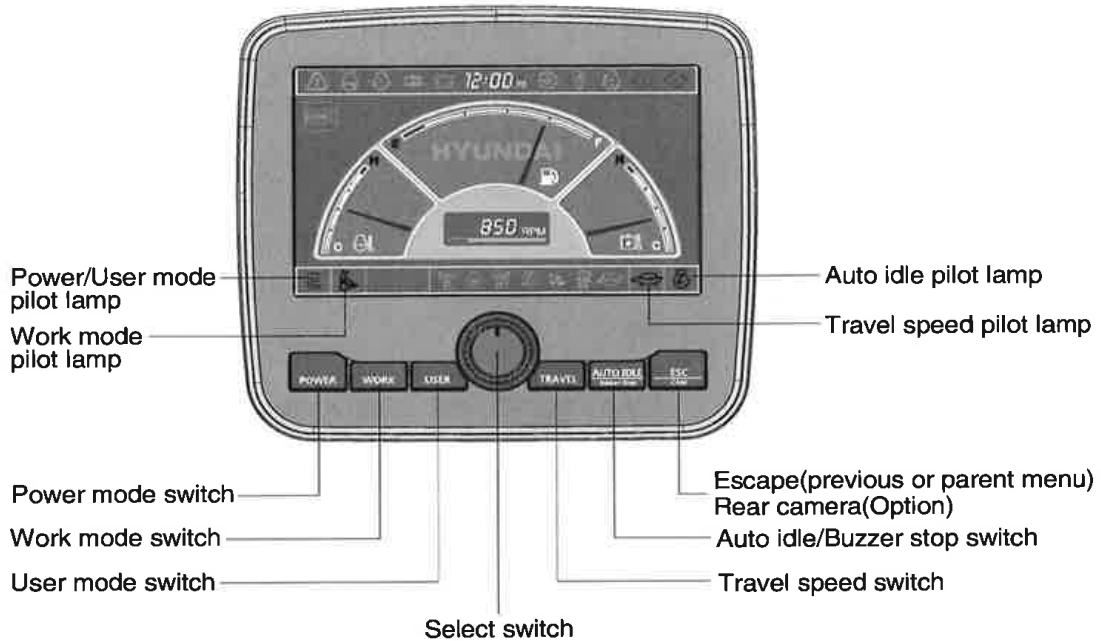

21093CD45

※ When the switches are selected, the pilot lamps are displayed on the LCD. Refer to the page 3-7 for details.

(1) Power mode switch



21093CD45A

- ① This switch is to select the machine power mode and selected power mode pilot lamp is displayed on the pilot lamp position.
 - P : Heavy duty power work.
 - S : Standard power work.
 - E : Economy power work.
- ② The pilot lamp changes E → S → P → E in order.

(2) Work mode switch



21093CD45C

- ① This switch is to select the machine work mode, which shifts from general operation mode to optional attachment operation mode.
 - : General operation mode
 - : Breaker operation mode (if equipped)
 - : Crusher operation mode (if equipped)
 - Not installed : Breaker or crusher is not installed.

※ Refer to the page 4-6 for details.

(3) User mode switch



21093CD45D

- ① This switch is used to memorize the current machine operating status in the MCU and activate the memorized user mode.
 - Memory : Push more than 2 seconds.
 - Action : Push within 2 seconds.
 - Cancel : Push this switch once more within 2 seconds.
- ② Refer to the page 3-12 for another set of user mode.

(4) Select switch



21093CD45E

- ① This switch is used to select or change the menu and input value.
- ② Knob push
 - Long (over 1.5 sec) : Return to the operation screen
 - Medium (0.5~1.0 sec) : Return to the previous screen
 - Short (below 0.5 sec) : Select menu
- ③ Knob rotation

This knob changes menu and input value.

 - Right turning : Down direction / Increase input value
 - Left turning : Up direction / Decreased input value

(5) Auto idle/ buzzer stop switch





21093CD45F

- ① This switch is used to activate or cancel the auto idle function.
 - Pilot lamp ON : Auto idle function is activated.
 - Pilot lamp OFF : Auto idle function is cancelled.
- ② The buzzer sounds when the machine has a problem. In this case, push this switch and buzzer stops, but the warning lamp blinks until the problem is cleared.

(6) Travel speed control switch



21093CD45G

- ① This switch is used to select the travel speed alternatively.
 -  : High speed
 -  : Low speed

(7) Escape/Camera switch



21093CD45H

- ① This switch is used to return to the previous menu or parent menu.
- ② In the operation screen, pushing this switch will display the view of the camera on the machine (if equipped). Please refer to page 3-22 for the camera.
- ③ If the camera is not installed, this switch is used only ESC function.

(2) Mode setup

① Work tool



- A : Select one installed optional attachment.
- B : Max flow - Set the maximum flow for the attachment.
 Flow level - Reduce the operating flow from maximum flow.
 Breaker - Max 7 steps, Reduced 10 lpm each step.
 Crusher - Max 4 steps, Reduced 20 lpm each step.

※ The flow level is displayed with the work mode pilot lamp.

② U mode power



- Engine high idle rpm, auto idle rpm and pump torque (power shift) can be modulated and memorized separately in U-mode.
- U-mode can be activated by user mode switch.

Step (█)	Engine speed (rpm)	Idle speed (rpm)	Power shift (bar)
1	1500	700	0
2	1550	750	2
3	1600	800	4
4	1650	850 (low idle)	7
5	1700	900	12
6	1750	950	15
7	1800	1000 (decel rpm)	20
8	1850	1050	24
9	1900	1100	28
10	1950	1150	33

③ Boom/Arm speed



- **Boom speed**
 - Control type
 - Manual - Boom up speed is fixed as set steps.
 - Auto - Boom up speed is automatically adjusted as working conditions by the MCU.
 - Speed setting - Boom up speed is increased as much as activated steps.
- **Arm speed**
 - Regeneration - Arm regeneration function can be activated or cancelled.
 - Enable - Arm in speed is up.
 - Disable - Fine operation.

④ Auto power boost



- The power boost function can be activated or cancelled.
- Enable - The digging power is automatically increased as working conditions by the MCU. It is operated max 8 seconds.
- Disable - Not operated.

⑤ Initial mode



- Default - The initial power mode is set E mode when the engine is started.
- U mode - The initial power mode is set U mode when the engine is started.

⑥ Cluster switch (back up)



- The cluster switch can be selected and changed by this menu when the switches are abnormal on the cluster.
- In order to exit "Cluster switch" mode, please put the cursor on the ESC/CAM switch by turning the select switch and push the select switch.
- In "Cluster switch", other switches except "Select switch" do not work.



(3) Monitoring

① Active fault



• The active faults of the MCU or engine ECM can be checked by this menu.

② Logged fault



• The logged faults of the MCU or engine ECM can be checked by this menu.

③ Delete logged fault



• The logged faults of the MCU or engine ECM can be deleted by this menu.

④ Monitoring(Analog)



• The machine status such as the engine rpm, oil temperature, voltage and pressure etc. can be checked by this menu.

⑤ Monitoring (digital)



- The switch status or output status can be confirmed by this menu.
- The activated switch or output pilot lamps are light ON.

⑥ Operating hours



- The operating hour of each mode can be confirmed by this menu.

② Machine security



21093CD67C



21093CD67D



21093CD67E

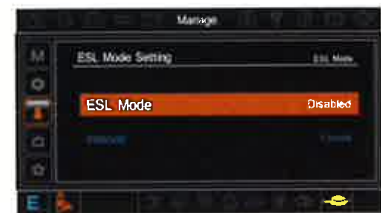

21093CD67EE



21093CD67H

• ESL mode

- ESL : Engine Starting Limit
- ESL mode is designed to be a theft deterrent or will prevent the unauthorized operation of the machine.
- If the ESL mode was selected Enable, the password will be required when the start switch is turned ON.
- Disable : Not used ESL function
- Enable (always) : The password is required whenever the operator start engine.
- Enable (interval) : The password is required when the operator start engine first. But the operator restarts the engine within the interval time, the password is not required. The interval time can be set maximum 4 hours.



21093CD67U



Enter the current password 21093CD67V



Enter the new password 21093CD67W

• Password change

- The password is 5~10 digits.



21093CD67X

The new password is stored in the MCU.



21093CD67XX

Enter the new password again

③ Machine Information



- This can confirm the identification of the cluster, MCU, engine and machine.

④ A/S phone number



⑤ Service menu

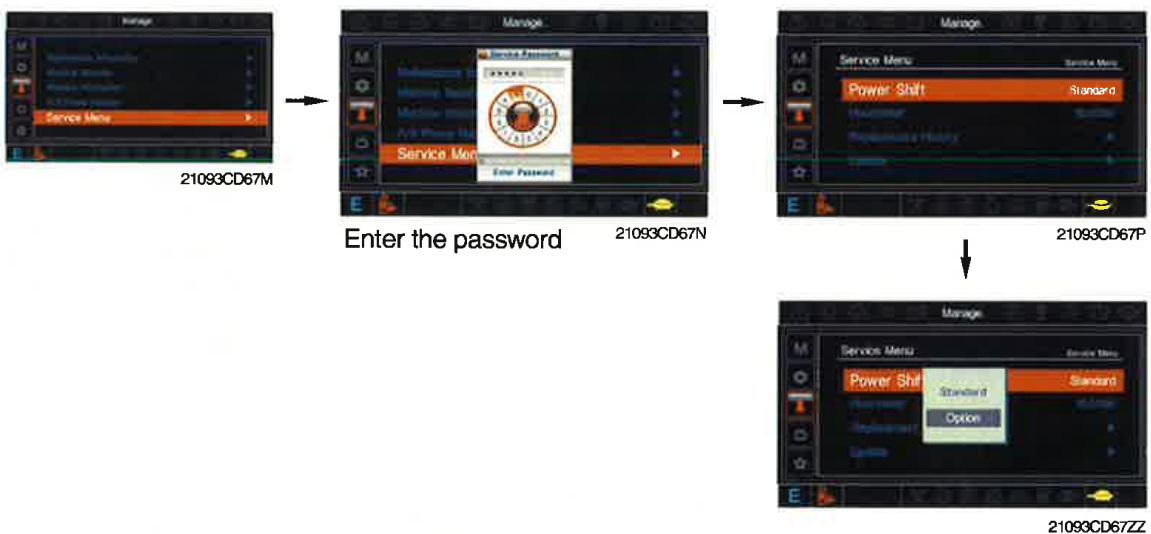

- Power shift (standard/option) : Power shift pressure can be set by option menu.
- Hourmeter start : Operating hours since the machine line out can be checked by this menu.
- Replacement history : Replacement history of the MCU and cluster can be checked by this menu.
- Update : Firm ware can be upgraded by this menu. (the USB port is located under the cluster)

(5) Display

① Display item



Center display

- The center display type of the LCD can be selected by this menu.
- The engine speed or each of the tripmeter (A,B,C) is displayed on the center display.

② Clock



- The first line's three spots "**/**/****" represent Month/Day/Year each.
- The second line shows the current time. (0:00~23:59)



③ Brightness

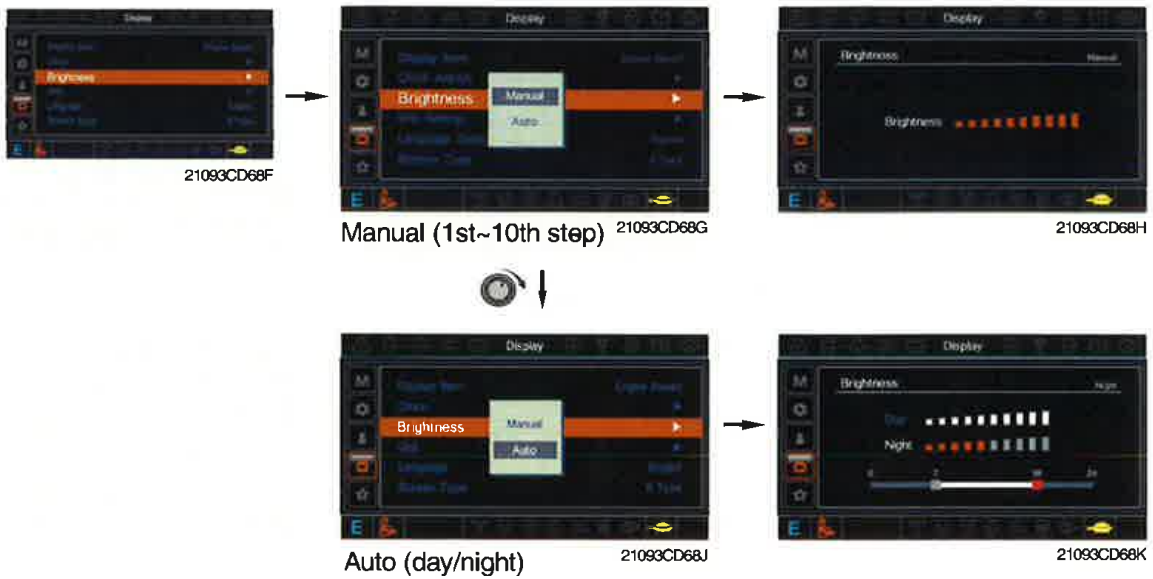

※ If "Auto" is chosen, brightness for day and night can be differently set up. Also by using the bar in lower side, users can define which time interval belongs to day and night. (in bar figure, gray area represents night time while white shows day time)

④ Unit



- Temperature : °C ↔ °F
- Pressure : bar ↔ MPa ↔ kgf/cm²
- Flow : lpm ↔ gpm
- Date format : yy/mm/dd ↔ mm/dd/yy ↔ dd-Mar-yy

⑤ Language



• User can select preferable language and all displays are changed the selected language.

⑥ Screen type

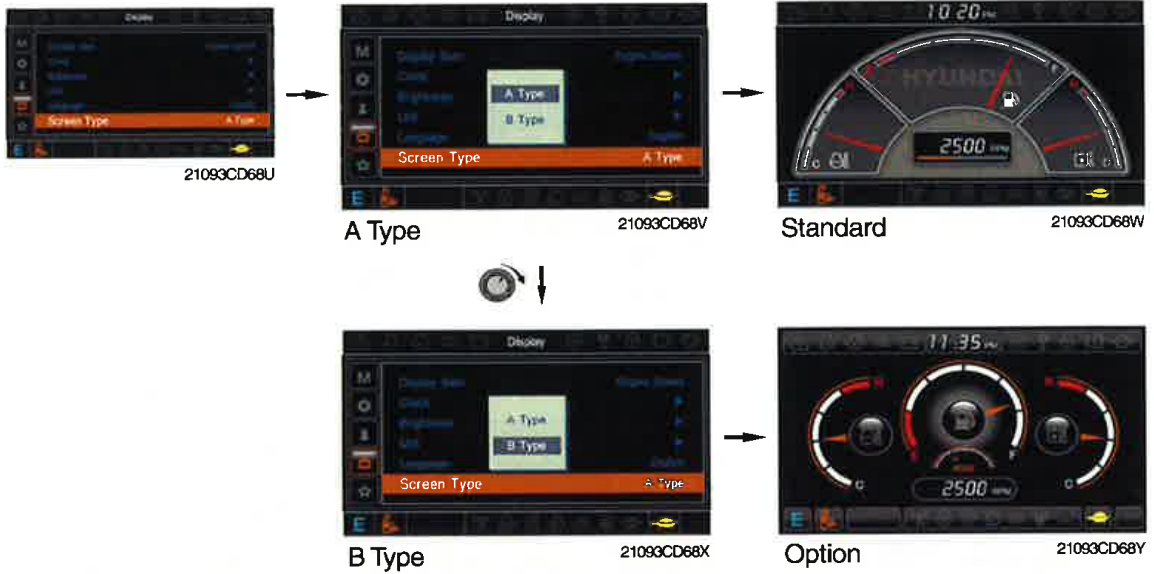

⑥ Utilities

① Tripmeter



- Maximum 3 kinds of tripmeters can be used at the same time.
- Each tripmeter can be turned on by choosing "Start" while it also can be turned off by choosing "Stop".
- If the tripmeter icon is activated in the operation screen, it can be controlled directly there.

② DMB



- DMB select : TV channel can be selected by this menu.
- DAB select : Audio channel can be selected by this menu.
- Channel scan : This menu can be used other region for TV/Audio.
- Exit : Exit DMB menu

③ Entertainment

- Play MP4 or codec file of external hard disk through USB port.
- The USB port is located under the cluster.



21093CD69F



21093CD69G

④ Camera setting



21093CD69J



21093CD69K



21093CD69L

- Three cameras can be installed on the machine.
- The display order can be set by this menu.



21093CD69M



21093CD69N

- If the camera was not equipped, this menu is not useful.
- In the operation screen, if the ESC/CAM switch is pushed, the first ordered display camera will be viewed.
- Turning the select switch in clockwise direction, the next ordered will be shown and in counter-clockwise direction, the previously ordered will be shown.
- Push the select switch, the displayed screen will be enlargement.

⑤ Message box

- The history of the machine operating status can be checked by this menu.



21093CD69Q



21093CD69R

3. SWITCHES

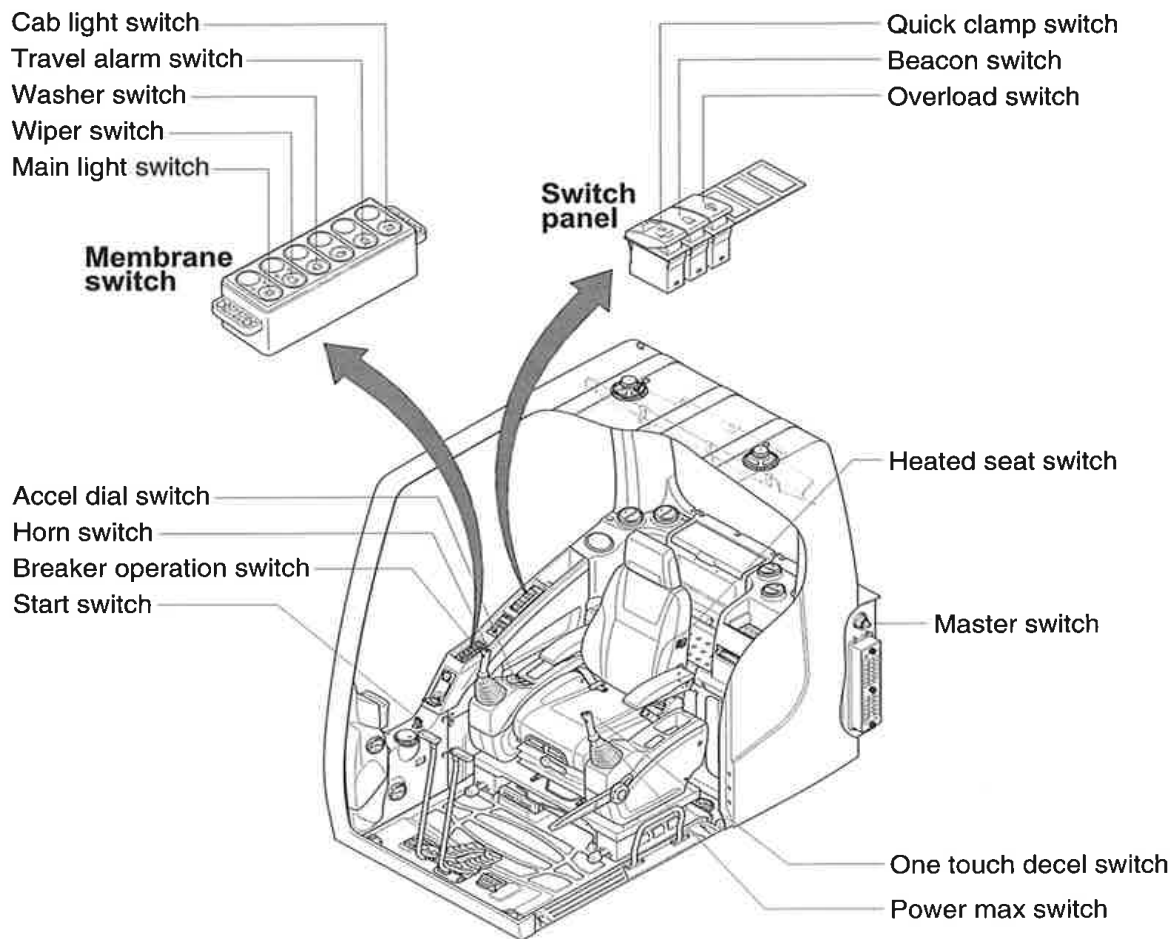

21093CD47

1) STARTING SWITCH



(1) There are three positions, OFF, ON and START.

- ○ (OFF) : None of electrical circuits activate.
- | (ON) : All the systems of machine operate.
- Ⓞ (START) : Use when starting the engine.

Release key immediately after starting.

- ※ If you turn ON the starting switch in cold weather, the fuel warmer is automatically operated to heat the fuel by sensing the coolant temperature. Start the engine in 1~2 minutes after turning ON the starting switch. More time may take according to ambient temperature.
- ※ Key must be in the ON position with engine running to maintain electrical and hydraulic function and prevent serious machine damage.

2) MASTER SWITCH

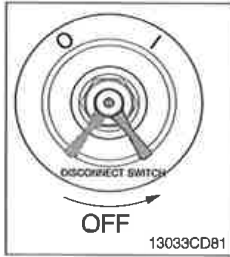

- (1) This switch is used to shut off the entire electrical system.
 - (2) I : The battery remains connected to the electrical system.
O : The battery is disconnected to the electrical system.
- ※ **Never turn the master switch to O (OFF) with the engine running. Engine and electrical system damage could result.**

3) ACCEL DIAL SWITCH

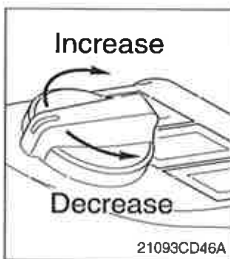

- (1) There are 10 dial setting.
- (2) Setting 1 is low idle and setting 10 is high idle.
 - By rotating the accel dial to right : Engine speed increases
 - By rotating the accel dial to left : Engine speed decreases

4) MAIN LIGHT SWITCH

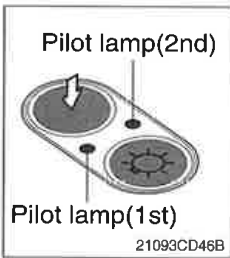

- (1) This switch used to operate the head light and work light.
 - Press the switch once, the head light comes ON and the 1st pilot lamp ON.
 - Press the switch once more, the work light comes ON and the 2nd pilot lamp ON.
 - Press the switch again, return to a first step position.
 - Press the switch more than one second to turn off lights.

5) WIPER SWITCH

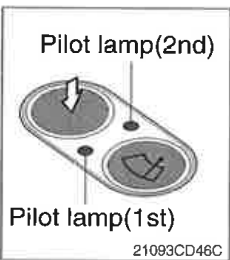

- (1) This switch used to operate wiper.
 - Press the switch once the wiper operates intermittently and the 1st pilot lamp comes ON.
 - Press the switch once more, the wiper operates low speed and the 2nd pilot lamp comes ON.
 - Press the switch again return to a first step position.
 - Press the switch more than one second to turn off wiper.

6) WASHER SWITCH

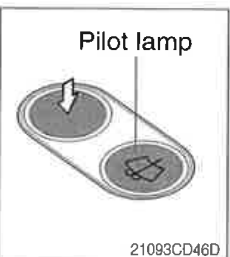

- (1) The washer liquid is sprayed and the wiper is operated only while pressing this switch.
- (2) The pilot lamp is turned ON when operating this switch.

7) TRAVEL ALARM SWITCH

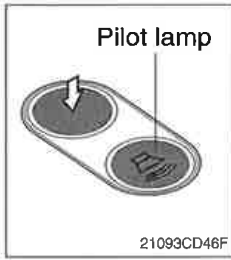

- (1) This switch is to activate travel alarm function surrounding when the machine travels to forward and backward.
- (2) On pressing this switch, the alarm operates only when the machine is traveling.

8) CAB LIGHT SWITCH (option)

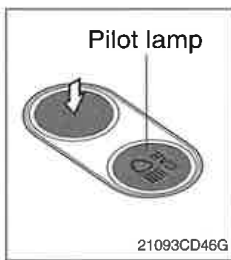

- (1) This switch turns ON the cab light on the cab.

9) OVERLOAD SWITCH (option)



- (1) When this switch turned ON, buzzer makes sound and overload warning lamp comes ON in case that the machine is overload.
- (2) When it turned OFF, buzzer stops and warning lamp goes out.

10) QUICK CLAMP SWITCH (option)



- (1) This switch is used to engage or disengage the moving hook on quick clamp.
- ※ Refer to the page 8-6 for details.

11) BEACON SWITCH (option)



- (1) This switch turns ON the rotary light on the cab.
- (2) The indicator lamp is turned ON when operating this switch.

12) HEATED SEAT SWITCH (option)



- (1) This switch is used to heat the seat.
 - Heater ON : 10 ± 3.5 °C
 - Heater OFF : 20 ± 3 °C
- (2) On pressing the switch, the indicator lamp is turned ON.

13) HORN SWITCH

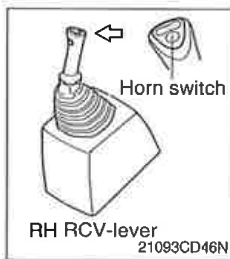

- (1) This switch is at the top of right side control lever. On pressing, the horn sounds.

14) BREAKER OPERATION SWITCH

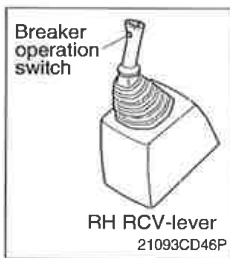

- (1) On pressing this switch, the breaker operates only when the breaker operation mode is selected.

15) ONE TOUCH DECEL SWITCH

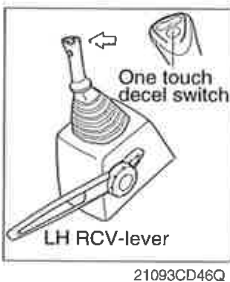

- (1) This switch is used to actuate the deceleration function quickly.
- (2) The engine speed is increased to previous setting value by pressing the switch again.
- (3) One touch decel function is available only when the auto idle pilot lamp is turned OFF.

16) POWER MAX SWITCH

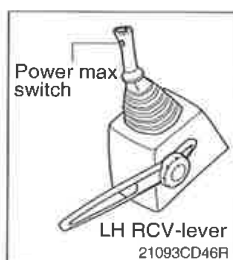

- (1) This switch activate power max function. When this switch is kept pressed, hydraulic power of work equipment will be increased to approx 110 percent during 8 seconds.
 - (2) After 8 seconds, function is cancelled automatically even the switch keeps pressed.
- ※ Do not use for craning purposes.

4. LEVERS AND PEDALS

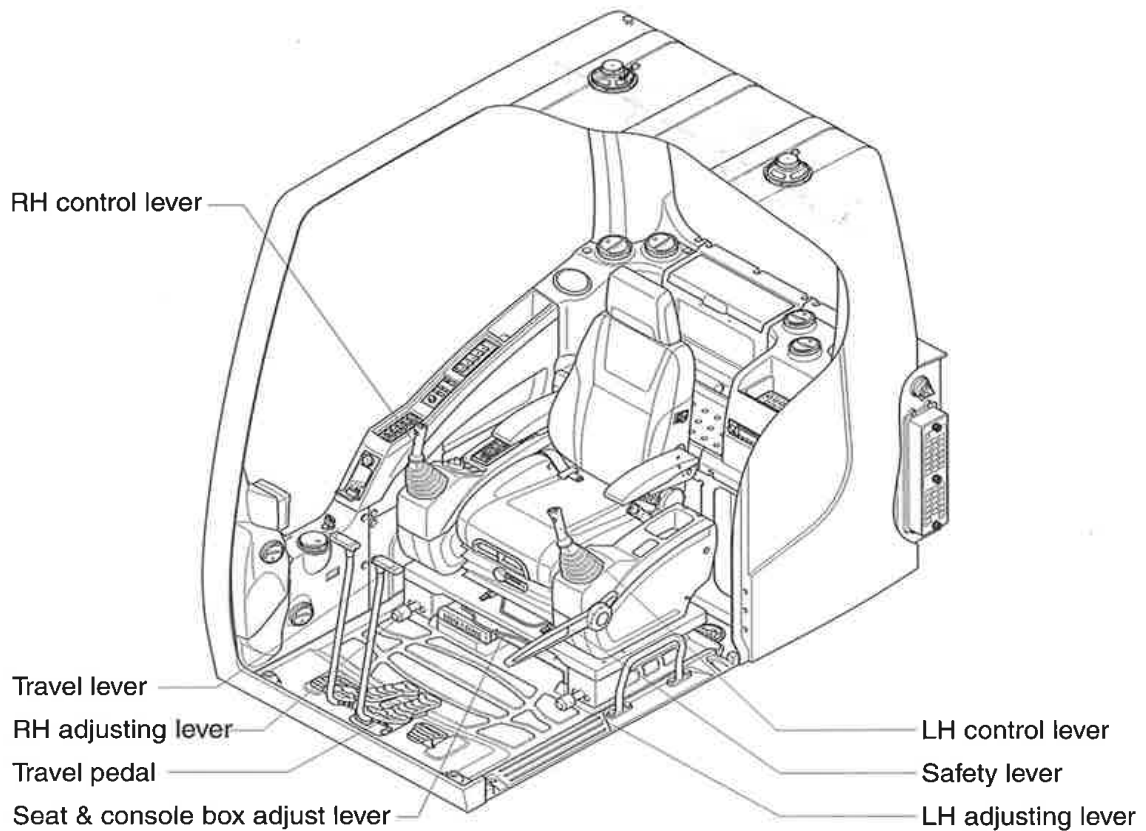

21093CD48

1) LH CONTROL LEVER



- (1) This joystick is used to control the swing and the arm.
- (2) Refer to operation of working device in chapter 4 for details.

2) RH CONTROL LEVER

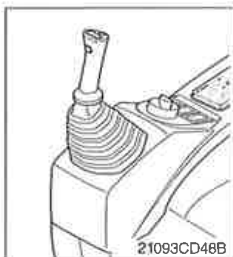

- (1) This joystick is used to control the boom and the bucket.
- (2) Refer to operation of working device in chapter 4 for details.

3) SAFETY LEVER

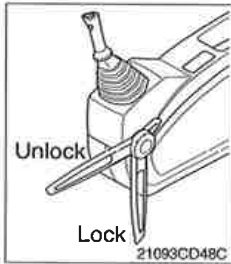

- (1) All control levers and pedals are disabled from operation by locating the lever to lock position as shown.
 - ※ Be sure to lower the lever to LOCK position when leaving from operator's seat.
- (2) By pull lever to UNLOCK position, the machine is operational.
 - ※ Do not use the safety lever for handle when getting on or off the machine.

4) TRAVEL LEVER



- (1) This lever is mounted on travel pedal and used for traveling by hand. The operation principle is same as the travel pedal.
- (2) Refer to traveling of the machine in chapter 4 for details.

5) TRAVEL PEDAL



- (1) This pedal is used to move the machine forward or backward.
- (2) If left side pedal is pressed, left track will move.
If right side pedal is pressed, right track will move.
- (3) Refer to traveling of machine in chapter 4 for details.

6) SEAT AND CONSOLE BOX ADJUST LEVER



- (1) This lever is used to move the seat and console box to fit the contours of the operator's body.
- (2) Pull the lever to adjust forward or backward over 170mm(6.7").

7) ADJUSTING LEVER

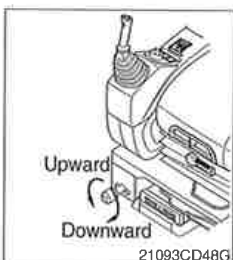

- (1) This lever is used to move the LH and RH control lever to fit the contours of the operator's body.
- (2) The control lever can be moved upward and downward over 30 mm (1.2").

5. AIR CONDITIONER AND HEATER

■ FULL AUTO AIR CONDITIONER AND HEATER (standard)

Full auto air conditioner and heater system automatically keeps the optimum condition in accordance with operator's temperature configuration sensing ambient and cabin inside temperature.

※ Refer to the page 3-33 for semi auto air conditioner and heater.

- Location of air flow ducts

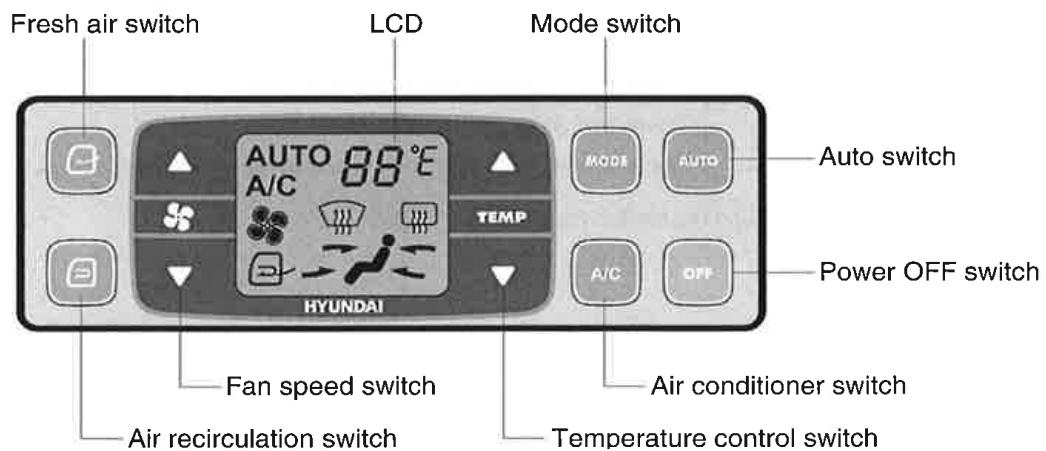
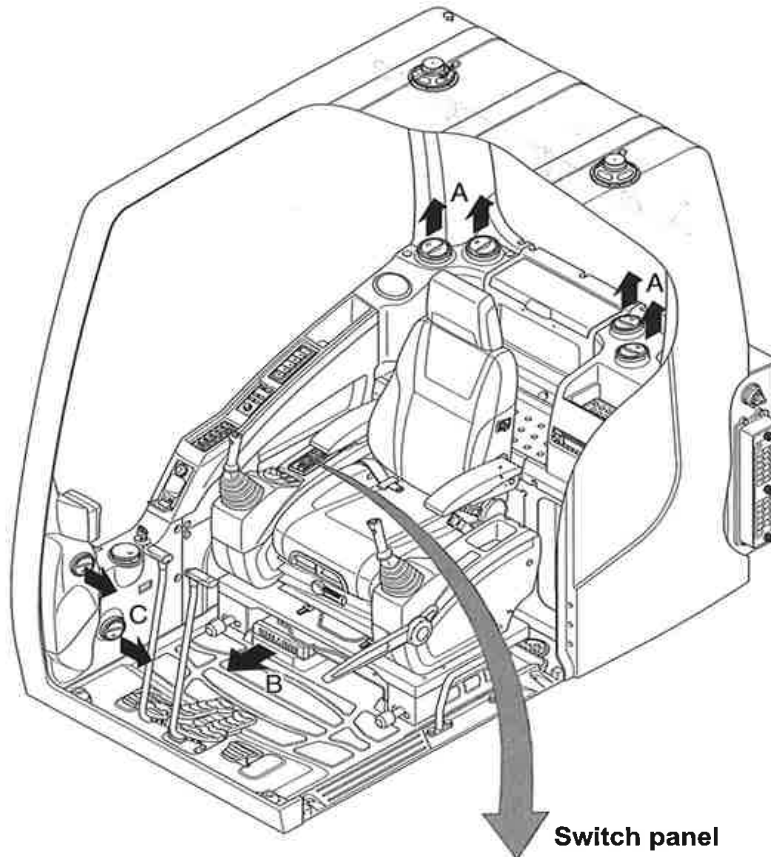

21093CD49

1) POWER OFF SWITCH



- (1) This switch makes the system and the LED OFF.
Just before the power OFF, set values are stored.

(2) Default setting values

Function	Air conditioner	In/outlet	LCD	Temperature	Mode
Value	OFF	Inlet	OFF	Previous sw OFF	Previous sw OFF

2) AUTO SWITCH



- (1) Turn the starting switch to ON position, LCD lights ON.
Auto air conditioner and heater system automatically keeps the optimum condition in accordance with operator's temperature configuration sensing ambient and cabin inside temperature.

- (2) This switch can restart system after system OFF.

3) AIR CONDITIONER SWITCH (compressor switch)



- (1) This switch turns the compressor and the LCD ON.
(2) In accordance with the temperature sensed by duct (evaporator) sensor, compressor turns ON or OFF automatically.

- ※ Air conditioner operates to remove vapor and drains water through a drain hose. Water can be sprayed into the cab in case that the drain cock at the ending point of drain hose has a problem.

In this case, exchange the drain cock.

4) FAN SPEED SWITCH

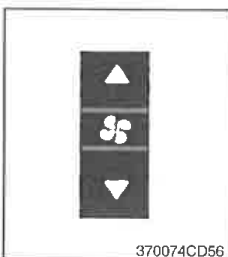

- (1) Fan speed is controlled automatically by setted temperature.
(2) This switch controls fan speed manually.
· There are 8 up/down steps to control fan speed.
· The maximum step or the minimum step beeps 5 times.
(3) This switch makes the system ON.

5) TEMPERATURE CONTROL SWITCH



- (1) Setting temperature indication (17~32°C, scale : 1°C)
- (2) Max cool and max warm beeps 5 times.
- (3) The max cool or the max warm position operates as following table.

Temperature	Compressor	Fan speed	In/Outlet	Mode
Max cool	ON	Max (Hi)	Recirculation	Vent
Max warm	OFF	Max (Hi)	Fresh	Foot

- (4) Temperature unit can be changed between celsius (°C) and fahrenheit (°F)
 - ① Default status (°C)
 - ② Push Up/Down temperature control switch simultaneously more than 5 second displayed temperature unit change (°C → °F)

6) MODE SWITCH



- (1) Operating this switch, it beeps and displays symbol of each mode in order. (vent → B/L → foot → Def → vent)

Mode switch		Vent	B/L	Foot	Defroster
Outlet	A	●	●		
	B		●	●	●
	C				●

- (2) When defroster switch operating, FRESH AIR/AIR RECIRCULATION switch turns to FRESH AIR mode and air conditioner switch turns ON.
- (3) When this switch ON, the system operates with previous configuration.

7) FRESH AIR/AIR RECIRCULATION SWITCH

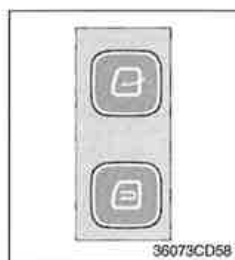

- (1) It is possible to change the air-inlet method.
 - ① Fresh air ()
Inhaling air from the outside.
* Check out the fresh air filter periodically to keep a good efficiency.
 - ② Air recirculation ()
It recycles the heated or cooled air to increase the energy efficiency.
* Change air occasionally when using recirculation for a long time.
* Check out the recirculation filter periodically to keep a good efficiency.



8) SELF DIAGNOSIS FUNCTION

(1) Procedure

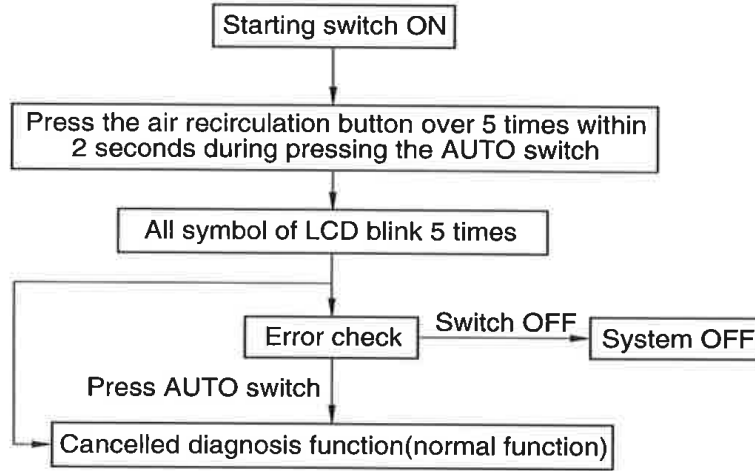

3607A3CD69

(2) Error check

- The corresponding error code flickers on the setup temperature display panel, the other symbol will turn OFF.
- Error code flickers every 0.5 second.
- If error code is more than two, each code flickers 2 times in sequence.
- Error code

Error code	Description	Error code	Description
11	Cabin inside sensor	15	Temp actuator
12	Ambient sensor	16	Mode actuator 1
13	Coolant temp sensor	17	Mode actuator 2
14	Duct (evaporator) sensor	18	Intake actuator

(3) Fail safe function

Error description	Fail safe function
Cabin inside sensor (11)	25°C alternate value control
Ambient sensor (12)	20°C alternate value control
Coolant temp sensor (13)	More than 10 minutes after engine start up, the alternate value is ON
Duct (evaporator) sensor (14)	1°C alternate value control
Temp actuator (15)	If opening amount is 0 %, the alternate value is 0 %
	If not, the alternate value is 100 %
Mode actuator 1, 2 (16, 17)	The alternate value is Vent



■ **SEMI AUTO AIR CONDITIONER AND HEATER (option)**

Semi auto air conditioner and heater are equipped for pleasant operation against outside temperature and defrost on window glass.

- Refer to the page 3-29 for full auto air conditioner and heater.
- Location of air flow ducts

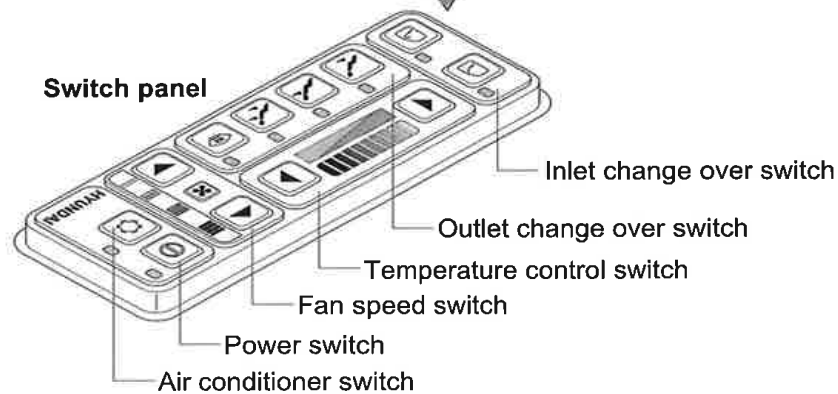
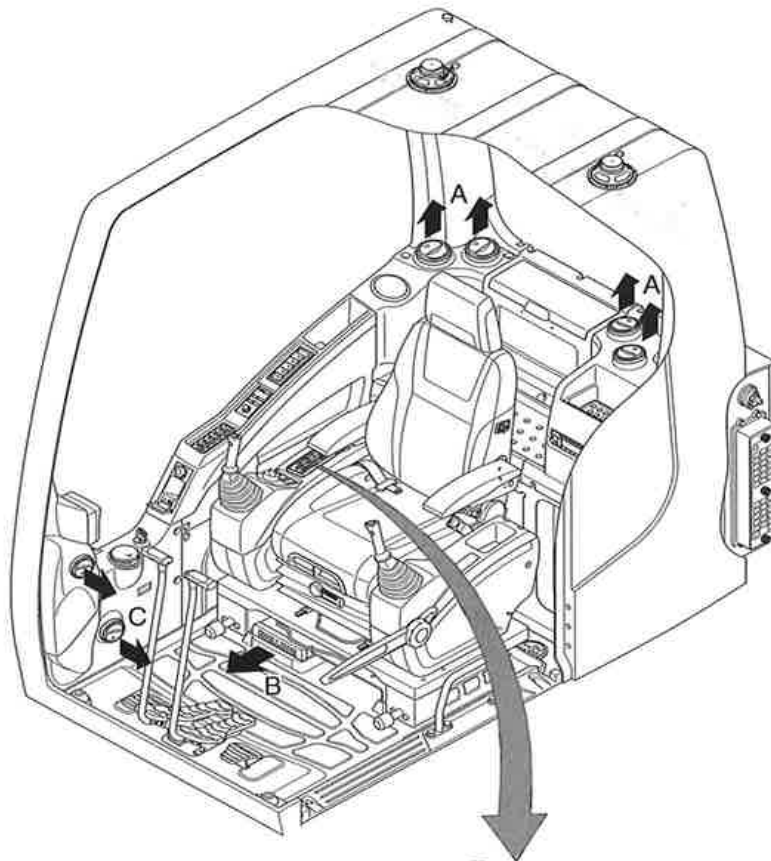

21093CD53

1) POWER SWITCH

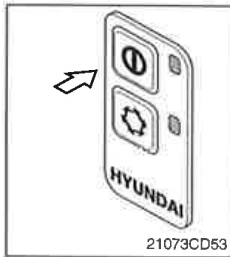

(1) This switch makes the system and the LED simultaneously ON or OFF.

(2) Default setting values

Function	Air conditioner	Fan speed	Temperature	Outlet	Inlet
Value	OFF	1	Max cool	Face	Recirculation

2) AIR CONDITIONER SWITCH (compressor switch)

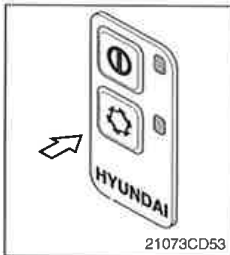

(1) Operating this switch turns the compressor and the LED simultaneously ON or OFF.

(2) In accordance with the evaporator temperature, compressor turns on or off automatically without changing LED state.

※ Air conditioner operates to remove vapor and drains water through a drain hose. Water can be sprayed into the cab in case that the vacuum valve of drain hose has a problem.

In this case, exchange the vacuum valve.

3) FAN SPEED SWITCH

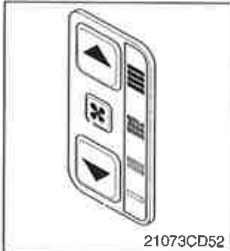

(1) It is possible to control the fan to four steps.

(2) The first step or the fourth step gives 5 times beeps.

4) TEMPERATURE CONTROL SWITCH

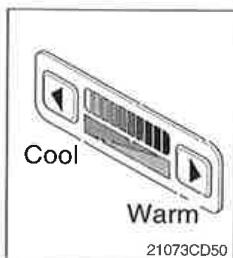

(1) There are 9 steps to control temperature from max cool to max warm controlled up and down by 1 step.

(2) Max cool and max warm arouse 5 times beeps.

(3) For the max warm or the max cool it's better to be configured as following table.

Temperature	Air conditioner	Fan speed	Outlet	Inlet
Max cool	ON	4	Face	Recirculation
Max warm	OFF	3	Foot	Fresh

5) OUTLET CHANGE OVER SWITCH

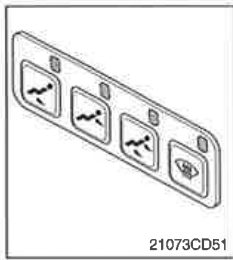

(1) There are four steps of air flow.

Switch position		Mode			
Outlet	A		●	●	
	B	●		●	●
	C				●

(2) When defroster switch operating, INLET switch turns to FRESH mode and air conditioner switch turns ON.

(3) In case of heating range (5~Max warm), air conditioner won't turn ON.

6) INLET CHANGE OVER SWITCH

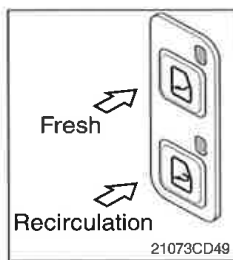

(1) It is possible to change the air-inlet method.

① Fresh

Inhaling air from the outside to pressurize cab inside.

※ Check out the fresh air filter periodically to keep a good efficiency.

② Recirculation

It recycles the heated or cooled air to increase the energy efficiency.

※ Change air occasionally when using recirculation for a long time.

※ Check out the recirculation filter periodically to keep a good efficiency.

(2) Recirculation function operates when the system is OFF but it can be changed whenever needed.

6. OTHERS

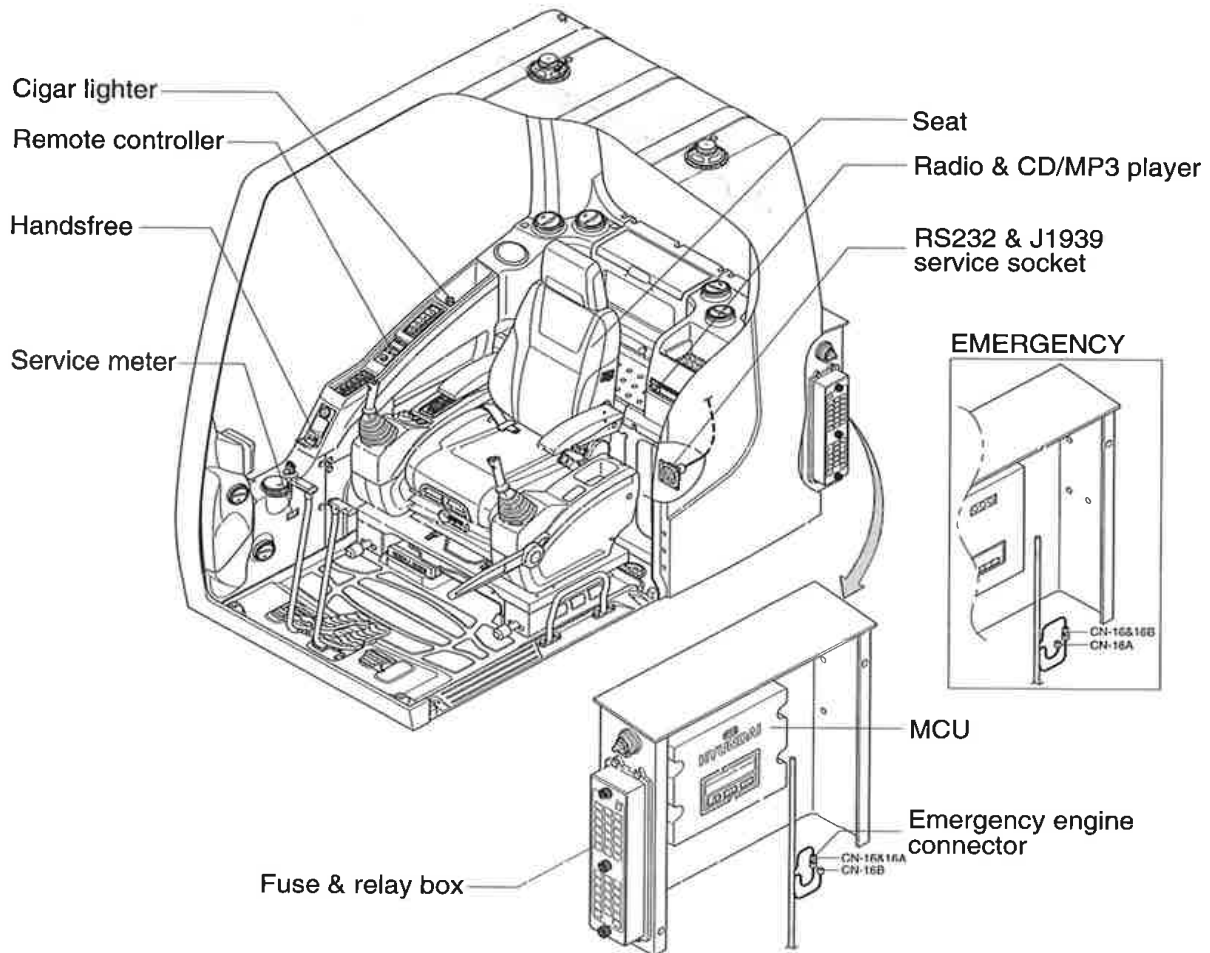

21093CD50

1) CIGAR LIGHTER



- (1) This can be used when the engine starting switch is ON.
- (2) The lighter can be used when it springs out in a short while after being pressed down.

※ **Service socket**

Use cigar lighter socket when you need emergency power.
Do not use the lighter exceeding 24V, 100W.

2) HANDSFREE

Allow you to dial a call or to have a conversation without holding your handset. Use the remote controller when making and answering a calls or ring off.

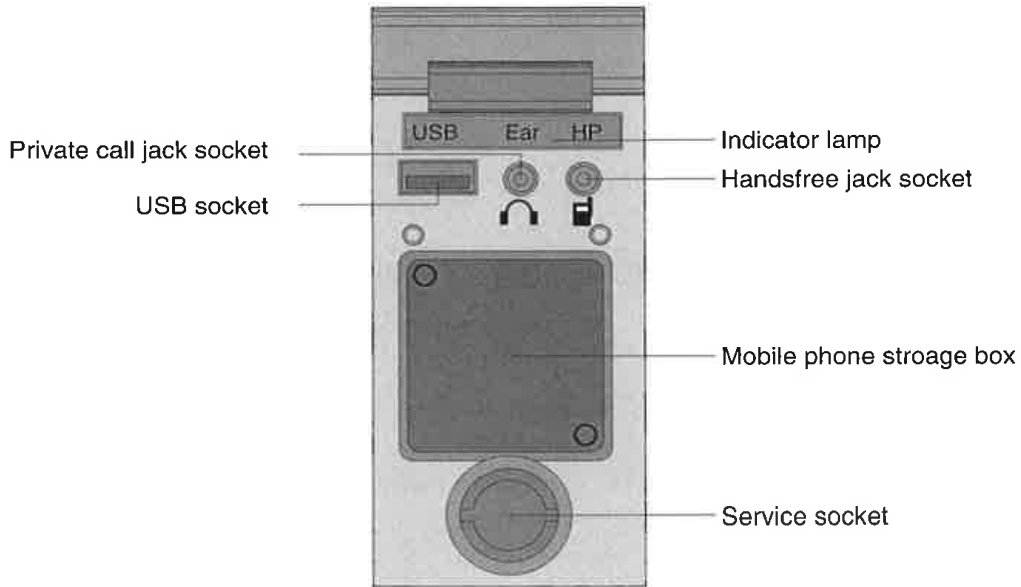

21093CD51

(1) Mobile phone storage box



21093CD51A

- ① Mobile phone can be stored when call by handsfree.

(2) USB socket



21093CD51B

- ① This socket is used to charging the mobile phone.

(3) Private call jack socket

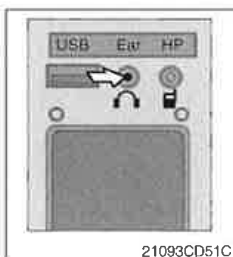

21093CD51C

- ① This can be used protect you privacy calling by using ear phone.
- ② The mobile phone must be connected handsfree jack socket.

(4) Handsfree jack socket



- ① Connect the jack cable when call by handsfree.
- ② Use the special adapter when jack cable is not interchangeable.
- ③ Check the jack type of mobile phone before use.

(5) Indicator lamp



- ① This lamp is turned ON when the handsfree mode selected.

(6) Service socket

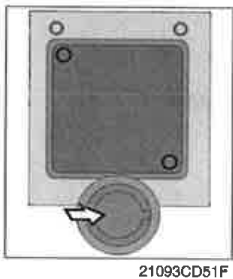

- ① Utilize the power of 12 V as your need and do not exceed power of 12 V, 30 W.

3) REMOTE CONTROLLER

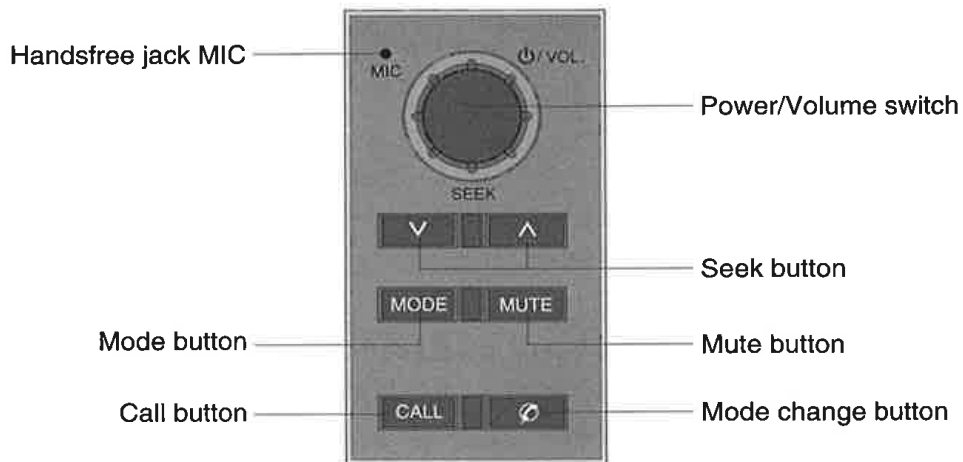

21093CD52

(1) Power and volume switch



21093CD52A

- ① This switch is used to turn the audio or handsfree ON or OFF.
 - ② This switch is turned to right, the handsfree volume is increased over 7 steps.
 - ③ If it is turned to left, volume will be decreased.
- ※ This switch adjust the audio volume when selected audio mode.

(2) Mode change button

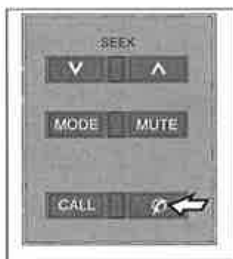

21093CD52B

- ① This button is to select the handsfree mode or audio mode.
 - Lamp ON : Handsfree mode ("TEL MUTE" displayed ON audio LCD)
 - Lamp OFF : Audio mode

(3) Call button

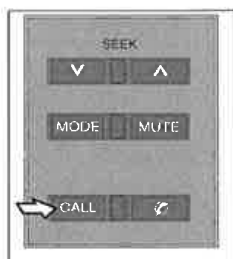

21093CD52C

- ① This button is used answer a call, last number redial, ring off.
 - ② For calling, press the button over 0.5sec within 3 seconds until the beep sounds.
- ※ This can be used when the starting switch is ON.

(4) Handsfree MIC





21093CD52D

- ① This MIC transfers user voice to receiver of the call when making a call by handsfree.

(5) Seek button



21093CD52E

- ① If this button pressed, the radio automatically stops at the next frequency of broadcasting for your listening.
- ② Press  to turn a station of a higher frequency or  to a lower frequency.

(6) Mute button

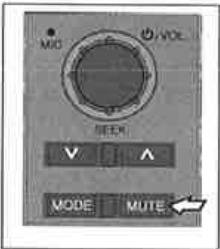

21083CD52G

- ① Short press this button to mute or cancel the mute (silence) while broadcasting.

(7) Mode button

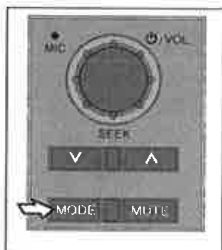

21093CD52F





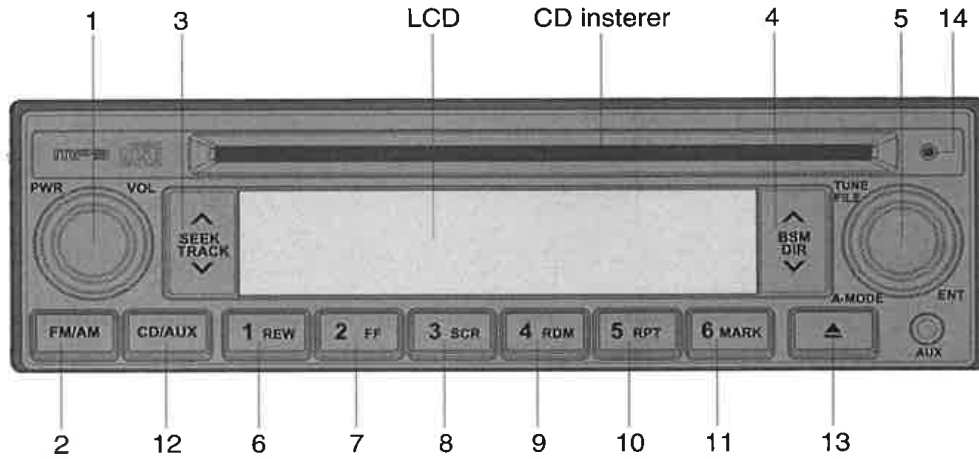







- ① Press the mode button to select the desired mode.
- ② FM1 → FM2 → AM → CD → MP3 → FM1
- ※ The LCD displayed each mode.

4) RADIO AND CD/MP3 PLAYER



21093CD70

■ FRONT PANEL PRESENTATION

- | | |
|--|---|
| <p>1  Power and volume switch
 PWR Press to power on/off
 VOL Turn right/left to adjust the volume</p> <p>2  AM/FM button (radio)</p> <p>3  Seek mode (radio)
 Auto search up/down
 Track mode(CD)
 Short press : Next/previous track
 Long press : Fast forward or rewind
 Memory file search up/down (MP3)</p> <p>4  BSM mode (radio)
 6 best station automatic memory
 DIR mode (MP3)
 Select the desired folder (MP3)
 Long press : Fast forward or rewind</p> <p>5  Manual frequency search (radio)
 Turn right/left to adjust the frequency
 FILE Search for desired file (CD/MP3)
 Turn right/left to adjust the track no
 A · MODE ... Select bass/middle/treble (radio)
 ENT Select the desired track (CD/MP3)</p> | <p>6  Preset memory button 1
 REW Fast rewind (CD)</p> <p>7  Preset memory button 2
 FF Fast forward (CD)</p> <p>8  Preset memory button 3
 SCR Scroll button (CD-MP3)</p> <p>9  Preset memory button 4
 RDM CD random playback on/off</p> <p>10  Preset memory button 5
 RPT CD repeat track on/off</p> <p>11  Preset memory button 6
 MARK Long press : MP3 file memory/deletion
 Short press : Memory file playback</p> <p>12  CD playback button
 Press to CD insert</p> <p>13  Disc eject (CD)</p> <p>14 CD indicator lamp</p> |
|--|---|

■ RADIO

(1) Power and volume switch



- ① **Power ON/OFF**
This switch is used to turn the audio ON or OFF.
- ② **Volume**
This switch turned to right or left, the sound is increased or decreased.



(2) FM/AM button



- ① You can broadcasting on AM or FM band by pressing this band selection button.
- ② The bands are changed in the following order.
FM1 → FM2 → AM → FM1

(3) Seek button



- ① If this button pressed, the radio automatically stops at the next frequency of broadcasting for your listening.
- ② Press  to turn a station of a higher frequency or  to a lower frequency.

(4) BSM (best station memory) button



- ① You can automatically memory 6 strongest FM stations on the FM BSM band or 6 strongest AM stations on the AM BSM band.
 - Press BSM to active best station memory.
 - The set gives a beep and then mutes.
 - When it has finished, you heard a beep followed by the station memoried on preset 1.
 - Sometimes it may not be possible to find 6 stations.

(5) Manual tuning/audio mode button

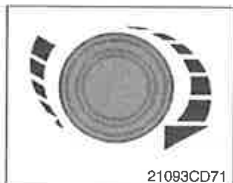

- ① It is possible to change manual tuning while broadcasting.
 - Turned to right or left, the frequency is increased or decreased.
- ② **Audio mode (Bass/Middle/Treble)**
 - Press this button to select desired audio mode.
 - Adjust the settings with the volume button right/left.
 - BASS : Press the button once
 - MIDDLE : Press the button twice
 - TREBLE : Press the button three times
- ③ If it is pressed four times, BALANCE will be selected.
 - Turned to clockwise, the LH speaker volume is decreased and counterclockwise, the RH speaker volume is decreased.

(6) Preset memory button

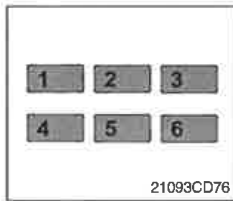

① Manually storing stations in a preset

Six stations per band can be stored and recalled using the preset keys (1 to 6).

- Tune in to the desired station.
- Press the desired preset key (1 to 6) for more than 0.8 seconds to store the current tuned station.

② Recalling a preset

Press the desired preset key (1 to 6) to recall the stored station.

(7) Frequency band setting

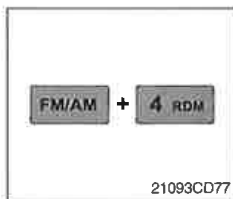

① America : Press **FM/AM** and **4 RDM** button at the same time. "nA" will be displayed on the LCD for one second.

AM : Frequency changes in 10kHz between 530 to 1710kHz.

FM : Frequency changes in 0.2MHz between 87.7 to 107.9MHz.

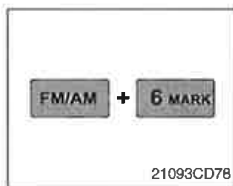

① EUROPE : Press **FM/AM** and **6 MARK** button at the same time. "Eu" will be displayed on the LCD for one second.

LW : Frequency changes in 9kHz between 153 to 279kHz.

MW : Frequency changes in 9kHz between 531 to 1620kHz.

FM : Frequency changes in 0.05MHz between 87.5 to 108.0MHz.

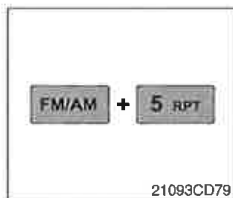

① General : Press **FM/AM** and **5 RPT** button at the same time. "inT" will be displayed on the LCD for one second.

AM : Frequency changes in 9kHz between 531 to 1602kHz.

FM : Frequency changes in 0.1MHz between 87.5 to 108.0MHz.

■ CD/MP3 PLAYER

(1) CD playback button



- ① It is possible to change CD playback during broadcasting.
- ② If there was no CD on audio, "NO DISC" displays on LCD during 5 seconds.

(2) Track button



- ① CD player
 - Short press : Select the next/previous track
 - Long press : Select the fast forward or rewind
- ② MP3 player
 - Memory file search up/down

(3) DiR mode button (MP3)



- ① You can find the desired mp3 folder up/down.
- ② If you find desired folder, press the file search button to playback the first file in the folder.
- ※ If a file is not selected until 5 seconds after search folder, the function will be terminated.

(4) File search button

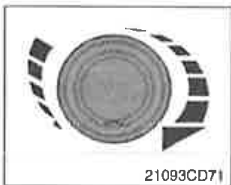

- ① It is possible to search the desired CD track or mp3 file.
 - Turned to clockwise, the CD track or mp3 file number is increased.
 - If it is turned to counterclockwise, CD track or mp3 file number is decreased.
- ※ If a file or track is not selected until 5 seconds, function will be terminated.

(5) Fast rewind/Fast forward button (CD)



- ① Continually press these button to quickly move rewind or forward through the disc.
- ※ The CD player sound level is lower while press this button.
- ② Normal playback resumes when you release the button.

(6) Random track button (CD)



- ① Press this button to activate random track playback.
- ※ The LCD displays "RDM".
- ② It is canceled press one more this button.

(7) Repeat track button (CD)



- ① Press this button to activate repeat current track playback.
- ※ The LCD displays "RPT".
- ② It is canceled press one more this button.

(8) Mark button (MP3)



- ① Memory
 - Press over 0.8 second, the current file memorized with a beep (max 100 tune memory).
- ※ The LCD displays "M" and "Marked number" for 3 seconds.
- ② Memory file playback
 - Press within 0.8 second, the marked file playback.
- ③ Deletion
 - Press over 0.8 second, the marked file will be deleted with a beep.

(9) CD EJECT BUTTON



- ① Press this button to eject the disc.
- ※ If there is no disc in the audio, the LCD displays "NO disc" for 5 seconds.

(10) SCR BUTTON (MP3)



- ① This button to confirm the long file name on LCD.

5) SEAT

The seat is adjustable to fit the contours of the operator's body. It will reduce operator fatigue due to long work hours and enhance work efficiency.

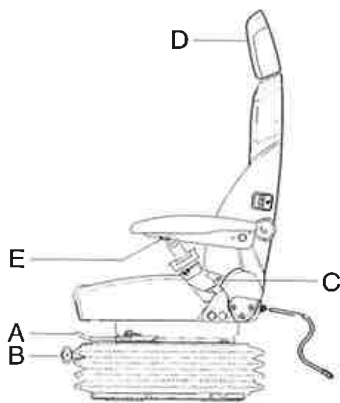
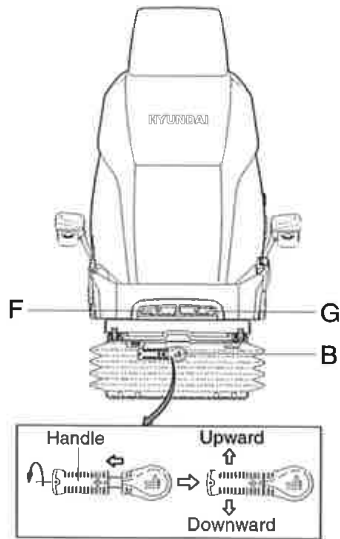

21093CD55

(1) Forward/Backward adjustment (A)

- ① Pull lever A to adjust seat forward or backward.
- ② The seat can be moved forward and backward over 140 mm (5.5") in 13 steps.

(2) Height/weight adjustment (B)

- ① Turn the handle to adjust seat upward or downward
 - Turn to clockwise, the seat is moved to upward and the weight is increased.
 - If it is turned to counterclockwise, the seat is moved to downward and the weight is decreased.
- ② **Method of changing direction (up/down)**
 - First, pull the handle to outside.
 - Second, rotate 180° and release the handle.

(3) Reclining adjustment (C)

Pull lever C to adjust seat back rest.

(4) Arm rest adjustment (E)

This can be adjusted by pushing the button E to right and left.

(5) Head rest adjustment (D)

This is adjustable vertically to fit operator's requirements over 60 mm (2.4").

(6) Seat cushion tilt adjustment (F)

Pull lever F to adjust seat cushion tilting angle.

(7) Seat cushion length adjustment (G)

▲ Pull lever G to adjust seat cushion forward or backward.

▲ Always check the condition of the seat belt and mounting hardware before operating the machine. Replace the seat belt at least once every three years, regardless of appearance.



6) FUSE & RELAY BOX

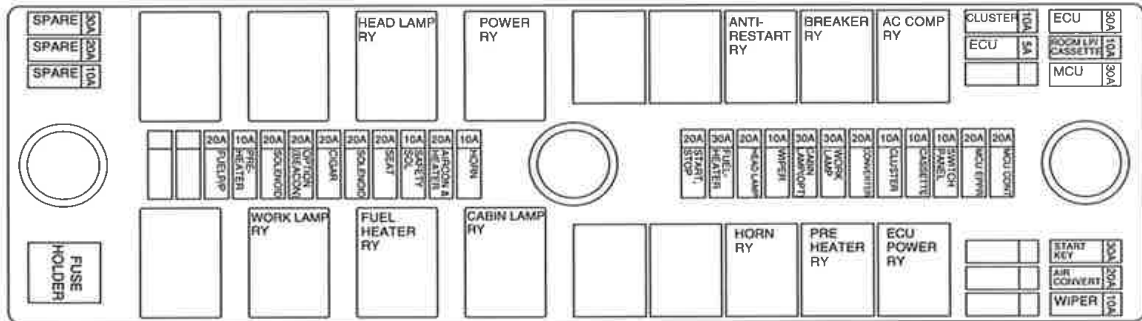

21093CD56

- (1) The fuses protect the electrical parts and wiring from burning out.
- (2) The fuse box cover indicates the capacity of each fuse and circuit it protects.
 - ※ Replace a fuse with another of the same capacity.
 - ▲ Before replacing a fuse, be sure to turn OFF the starting switch.

7) MCU

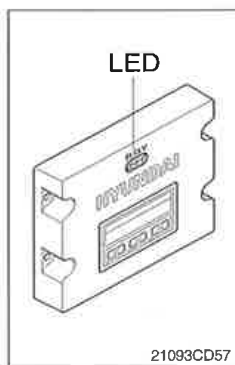

- (1) To match the pump absorption torque with the engine torque, MCU varies EPPR valve output pressure, which control pump discharge amount whenever feedbacked engine speed drops under the reference rpm of each mode set.
- (2) Three LED lamps on the MCU display as below.

LED lamp	Trouble	Service
G is turned ON	Normal	-
G and R are turned ON	Trouble on MCU	<ul style="list-style-type: none"> • Change the MCU
G and Y are turned ON	Trouble on serial communication line	<ul style="list-style-type: none"> • Check if serial communication lines between controller and cluster are disconnected
Three LED are turned OFF	Trouble on MCU power	<ul style="list-style-type: none"> • Check if the input power wire (24 V, GND) of controller is disconnected • Check the fuse

G : green, R : red, Y : yellow

8) EMERGENCY ENGINE STARTING CONNECTOR

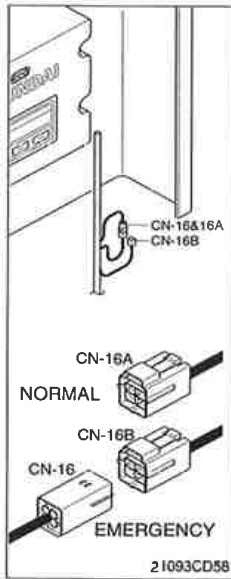

(1) Emergency starting

- ① If the MCU is removed, the engine does not start.
- ② Before starting the engine, connect the connector CN-16 with 16B.

(2) Emergency speed control

- ① When the CAN communication between the ECM and the MCU is abnormal due to malfunction of the MCU, change CN-16 connection from CN-16A to CN-16B and then control the engine speed by rotating accel dial switch.
- ※ Never connect connector CN-16 with CN-16B when MCU is in normal operation.

9) SERVICE METER



- (1) This meter shows the total operation hours of the machine.
- (2) Always ensure the operating condition of the meter during the machine operation. Inspect and service the machine based on hours as indicated in chapter 6, maintenance.

10) RS232 & J1939 SERVICE SOCKET

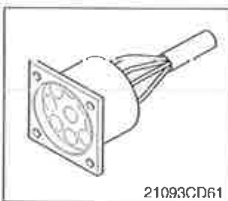

- (1) MCU communicates the machine data with Laptop computer through RS232 service socket.
- (2) ECM communicates the engine data with cummins **INSITE** adapter through J1939 service socket.
 - ① ECM fault code check
 - ② ECM program change
 - ③ Engine data monitoring & test

11) UPPER WINDSHIELD



(1) Perform the following procedure in order to open the upper windshield.

- ① Pull both levers with hold both grips that are located at the top of the windshield frame and push the windshield upward.
- ② Hold both grips and back into the lock position until auto lock latch is engaged, then release the lever locked position.



(2) Perform the following procedure in order to close the upper windshield.

- ① Pull the lever of the auto lock latch in order to release the auto lock latch.
- ② Reverse above step ① and ② in order to close the upper windshield.





OPERATION

1. SUGGESTION FOR NEW MACHINE

- 1) It takes about 100 operation hours to enhance its designed performance.
- 2) Operate according to below three steps and avoid excessive operation for the initial 100 hours.

Service meter	Load
Until 10 hours	About 60 %
Until 100 hours	About 80 %
After 100 hours	100 %

※ Excessive operation may deteriorate the potential performance of machine and shorten lifetime of the machine.

3) Be careful during the initial 100 hours operation

- (1) Check daily for the level and leakage of coolant, engine oil, hydraulic oil and fuel.
- (2) Check regularly the lubrication and fill grease daily all lubrication points.
- (3) Tighten bolts.
- (4) Warm up the machine fully before operation.
- (5) Check the gauges occasionally during the operation.
- (6) Check if the machine is operating normally during operation.

4) Replace followings after initial 50 or 250 hours of operation

Checking items	Hours
Engine oil	50
Engine oil filter element	
Fuel filter	
Prefilter	
Hydraulic oil return filter element	250
Hydraulic oil tank drain filter cartridge	
Line filter element	

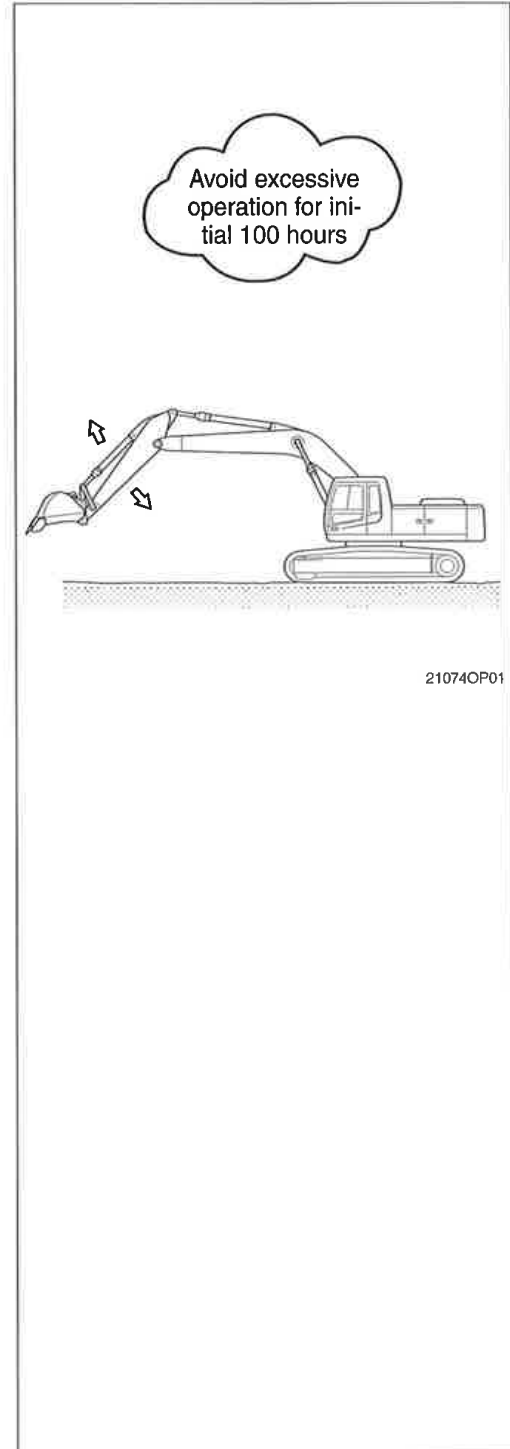

2. CHECK BEFORE STARTING THE ENGINE

- 1) Look around the machine and under the machine to check for loosened nut or bolts, collection of dirt, or leakage of oil, fuel or coolant and check the condition of the work equipment and hydraulic system. Check also loosened wiring, and collection of dust at places which reach high temperature.
 ※ Refer to the daily check on the chapter 6, maintenance.
- 2) Adjust seat to fit the contours of the operator's body for the pleasant operation.
- 3) Adjust the rear view mirror.

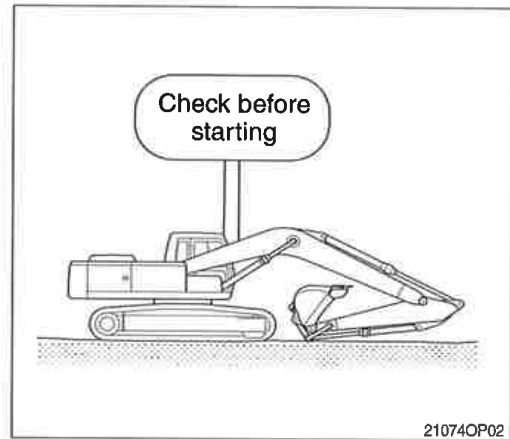

3. STARTING AND STOP THE ENGINE

1) CHECK INDICATOR LIGHTS

- (1) Check if all the operating levers are in the neutral position.
- (2) Turn the starting switch to the ON position.
Buzzer sounding for 4 seconds with HYUNDAI logo on cluster.
- ※ If the ESL mode is set to the enable, enter the password to start engine.
- ※ If the password has failed 5 times, please wait 30 minutes before re-attempting to enter the password.
- ※ Refer to page 3-17 for ESL mode.
- (3) After initialization of cluster, the operating screen is displayed on LCD (1).
Also, self-diagnostic function is carried out.

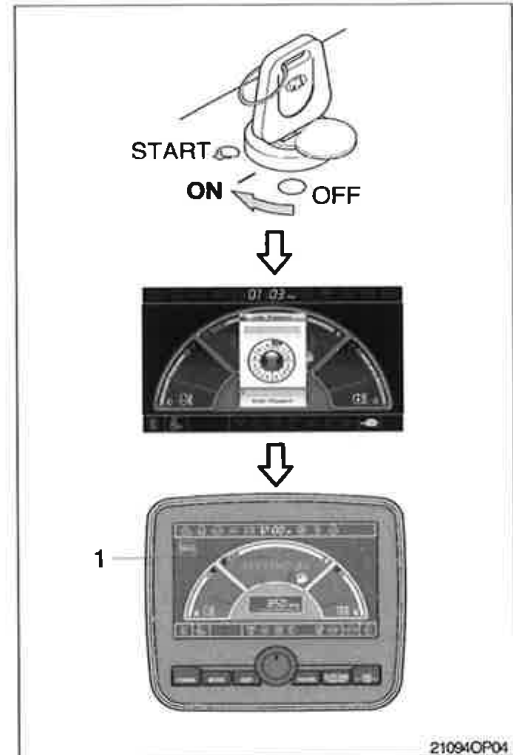

2) STARTING ENGINE IN NORMAL TEMPERATURE

- ※ Sound the horn to warn the surroundings after checking if personnel or obstacles are in the area.
- (1) Turn the starting switch to START position to start the engine.
 - ※ If the engine does not start, allow the starter to cool for about 2 minutes before re-attempting to start the engine again.
 - (2) Release the starting switch instantly after the engine starts to avoid possible damage to the starting motor.

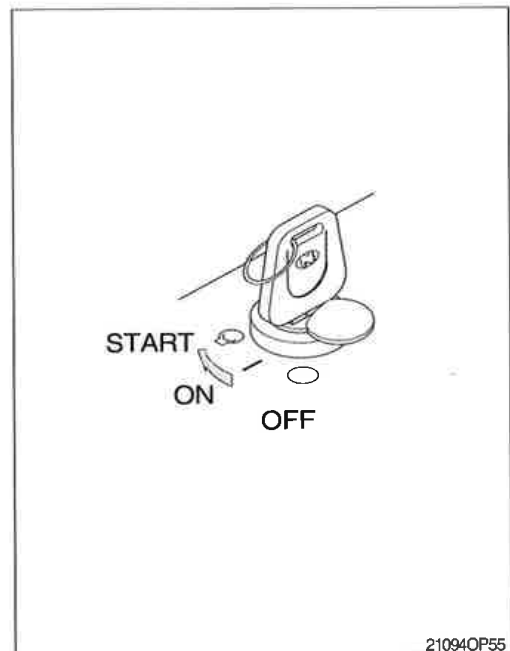



3) STARTING ENGINE IN COLD WEATHER

- ※ Sound horn to warn surroundings after checking if there are obstacles in the area.
- ※ Replace the engine oil and fuel referring to recommended oils at page 2-26.
- ※ Fill the anti-freeze solution to the coolant as required.
- ※ If you turn ON the starting switch, the fuel warmer is automatically operated to heat the fuel by sensing the coolant temperature.

- (1) Check if all the levers are in the neutral position.
- (2) Turn the starting switch to the ON position, and wait 1~2 minutes. More time may take according to ambient temperature.
- (3) Start the engine by turning the starting switch to the START position after the preheat pilot lamp OFF.
- ※ If the engine does not start, allow the starter to cool for about 2 minutes before attempting to start the engine again.
- (4) Release the starting switch immediately after starting engine.
- (5) The operation for warming up machine is automatic.

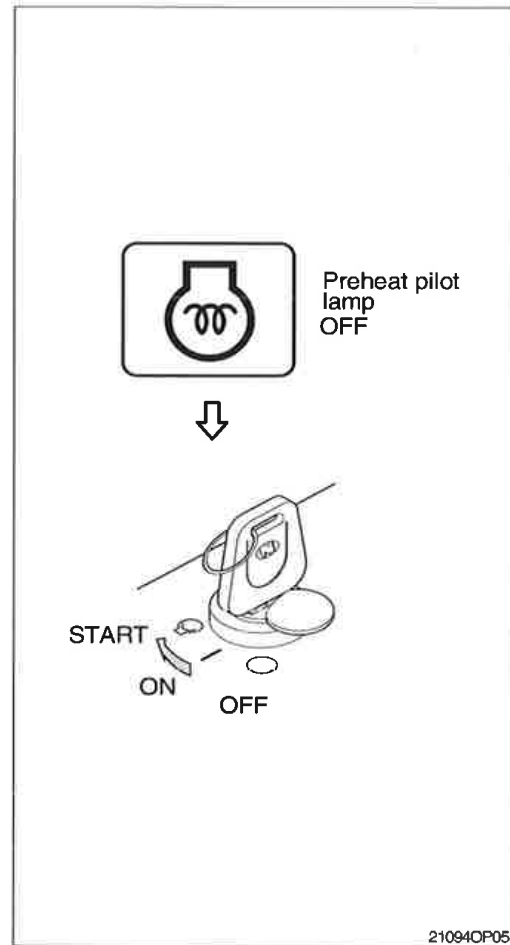

4) INSPECTION AFTER ENGINE START

Inspect and confirm the following after engine starts.

- (1) Is the level gauge of hydraulic oil tank in the normal level?
 - (2) Are there leakages of oil or water?
 - (3) Are all the warning lamps turned OFF (1-9)?
 - (4) Are the indicator of water temperature gauge (10) and hydraulic temperature gauge (11) in the operating range?
 - (5) Are the engine sound and the color of exhaust gas normal?
 - (6) Are the sound and vibration normal?
- ※ Do not increase engine speed quickly after starting, it can damage engine or turbocharger.
 - ※ If there are problems in the cluster, stop the engine immediately and correct problems as required.

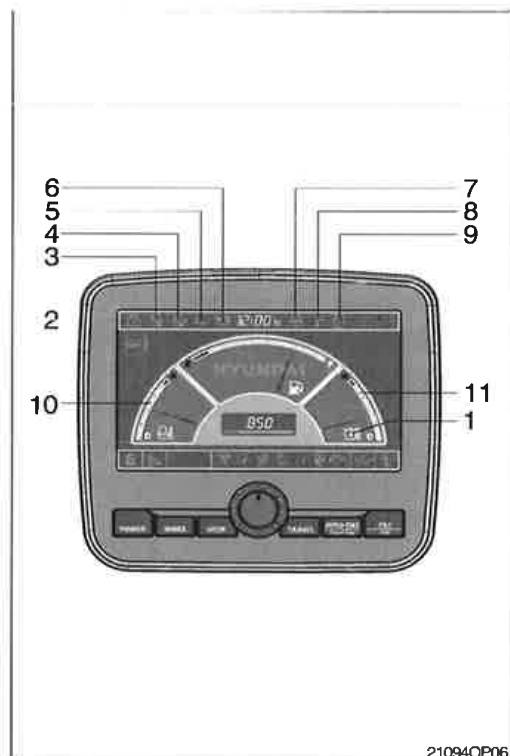



5) WARMING-UP OPERATION

- ※ The most suitable temperature for the hydraulic oil is about 50°C (122°F).
It can cause serious trouble in the hydraulic system by sudden operation when the hydraulic oil temperature is below 25°C (77°F).
Then temperature must be raised to at least 25°C (77°F) before starting work.
- (1) Run the engine at low idle speed for 5 minutes.
- (2) Speed up the engine by accel dial and run the engine at mid-range speed.
- (3) Operate bucket lever for 5 minutes.
※ **Do not operate anything except bucket lever.**
- (4) Run the engine at the high speed and operate the bucket lever and arm lever for 5-10 minutes.
※ **Operate only the bucket lever and arm lever.**
- (5) This warming-up operation will be completed by operation of all cylinders several times, and operation of swing and traveling.
※ **Increase the time for warming-up during winter.**

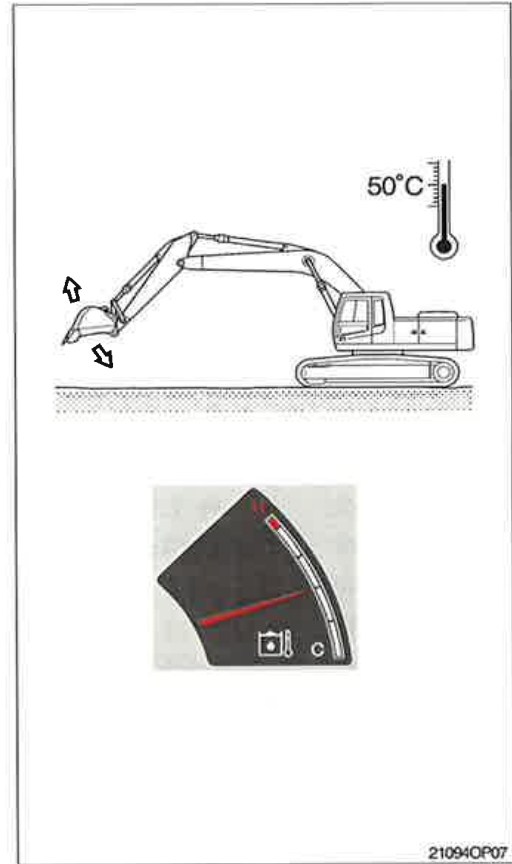

6) TO STOP THE ENGINE

- ※ If the engine is abruptly stopped before it has cooled down, engine life may be greatly shortened. Consequently, do not abruptly stop the engine apart from an emergency.
- ※ In particular, if the engine has overheated, do not abruptly stop it but run it at medium speed to allow it to cool gradually, then stop it.
- (1) Down the bucket on the ground then put all the levers in the neutral position.
- (2) Run the engine at low idle speed for about 5 minutes.
- (3) Return the key of starting switch to the OFF position.
- (4) Remove the key to prevent other people using the machine and LOCK safety lever.
- (5) Lock the cab door.

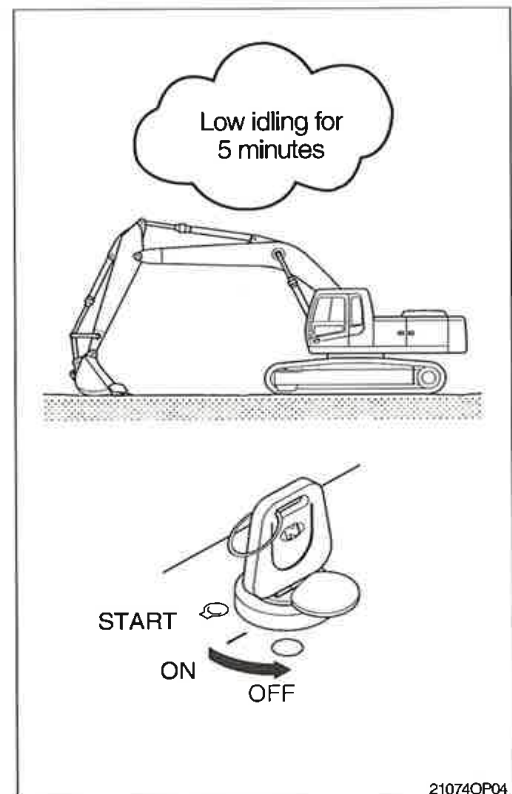

4. MODE SELECTION SYSTEM

1) STRUCTURE OF MECHATRONICS SYSTEM

CAPO, Computer Aided Power Optimization system, is the name of mode selection system developed by Hyundai.

※ Please refer to chapter 3, cluster for below modes setting.

(1) Power mode

Power mode designed for various work loads supports high performance and reduces fuel consumption.

- P mode : Heavy duty power
- S mode : Standard power
- E mode : Economy power

(2) Work mode

One of the two work modes can be selected for the optimal work condition of the machine operation.

① General work mode (bucket)

When key switch is turned ON, this mode is selected automatically.

② Work tool mode (breaker, crusher)

It controls the pump flow and system pressure for the optimal operation of breaker or crusher.

(3) User mode

① User mode is useful for setting the user preferable power quickly.
(engine speed, power shift and idle speed)

② There are two methods for use of user mode.

a. In operation screen

User mode switch is used to memorize the current machine operating status and activate the memorized user mode.

Refer to page 3-10.

b. In menu

Engine high idle rpm, auto idle rpm and pump torque (power shift) can be modulated and memorized separately in menu status.

- Each memory mode has a initial set which are mid-range of max engine speed, power shift and auto idle speed.

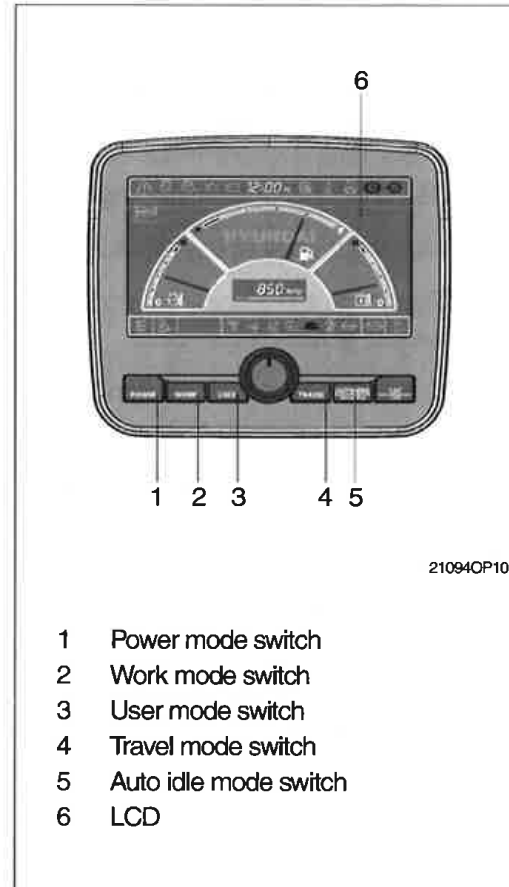

- 1 Power mode switch
- 2 Work mode switch
- 3 User mode switch
- 4 Travel mode switch
- 5 Auto idle mode switch
- 6 LCD

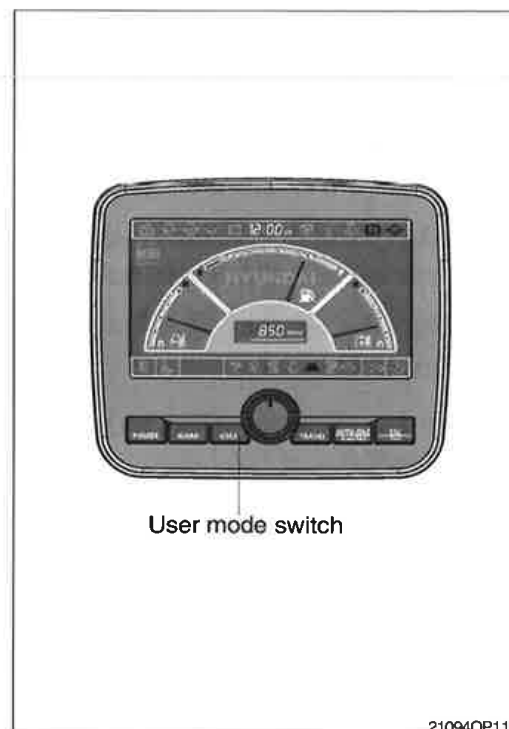



- High idle rpm, auto idle rpm and EPPR pressure can be adjusted and memorized in the U-mode.

※ Refer to the page 3-12 for setting the user mode (available on U mode only).



· LCD segment vs parameter setting

Step (■)	Engine speed (rpm)	Idle speed (rpm)	Power shift (bar)
1	1500	700	0
2	1550	750	2
3	1600	800	4
4	1650	850 (low idle)	7
5	1700	900	12
6	1750	950	15
7	1800	1000 (decel rpm)	20
8	1850	1050	24
9	1900	1100	28
10	1950	1150	33



21094OP12

(4) Travel mode

-  : Low speed traveling.
-  : High speed traveling.

(5) Auto idle mode

- Pilot lamp ON : Auto idle function is activated.
- Pilot lamp OFF : Auto idle function is canceled.

(6) Monitoring system

Information of machine performance as monitored by the MCU can be displayed on the LCD. Refer to the page 3-11.

(7) Self diagnostic system

① **MCU (Machine Control Unit)**

The MCU diagnoses machine status and problems and displays fault code in the cluster (fault code detected by MCU is composed of HCESPN and FMI).

② **Engine ECM (Electronic Control Module)**

If the engine or relevant system has problem, engine ECM detects and displays on the LCD as fault codes (this code is composed of SPN and FMI).

※ Refer to the page 3-11 for LCD display.

(8) Anti-restart system

The system protects the starter from inadvertent restarting after the engine is already operational.

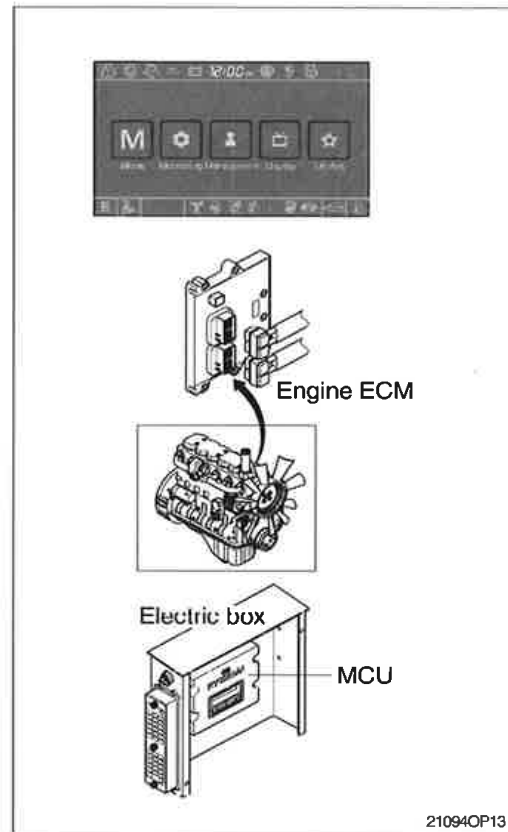

2) HOW TO OPERATE MODE SELECTION SYSTEM

(1) When start key switch is turned ON

- ① When start key switch is turned on, the cluster turns on and buzzer sounds for 4 seconds. And then main information as gauges and engine speed are displayed on LCD.
- ② Initial default mode settings are displayed in the cluster.

Mode		Status
Power mode	E	ON
Work mode		ON
Travel mode	Low (ON
Auto decel		ON

※ These setting can be changed at U mode.

- ③ Self-diagnostic function can be carried out from this point.

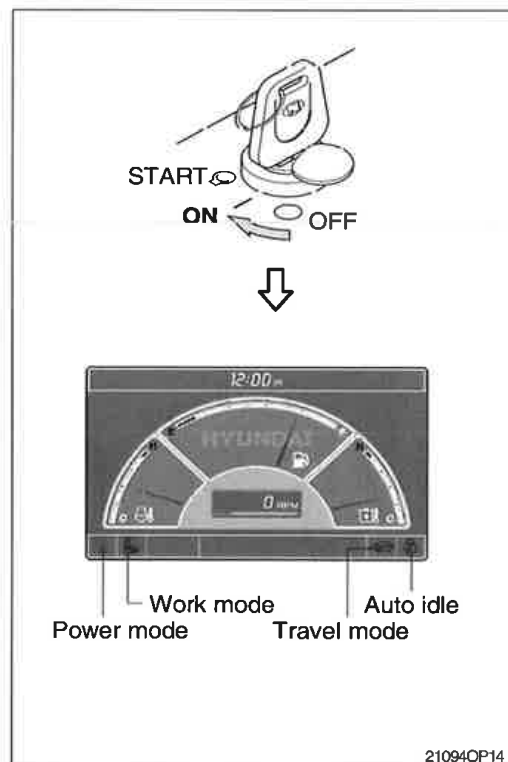



(2) After engine start

- ① When the engine is started, rpm display indicates low idle, 850 ± 100 rpm.
- ② If coolant temperature is below 30°C , the warming up pilot lamp lights ON and after 4 seconds the engine speed increases to 1000 ± 100 rpm automatically to warm up the machine.
 - After 2-3 minutes, you can select any mode depending on job requirement.

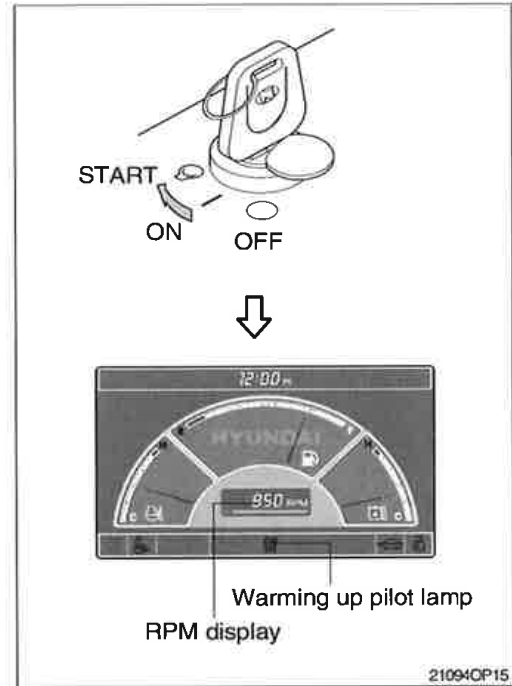

21094OP15

3) SELECTION OF POWER MODE

(1) E mode

The accel dial is set 10 and the auto idle mode is canceled.

Engine rpm	Effect
1600 ± 50	Variable power control in proportion to lever stroke (improvement in fuel efficiency) * Same power as S mode in full lever operation.

* When the accel dial is located below 9 the engine speed decreases about 50~100 rpm per dial set.

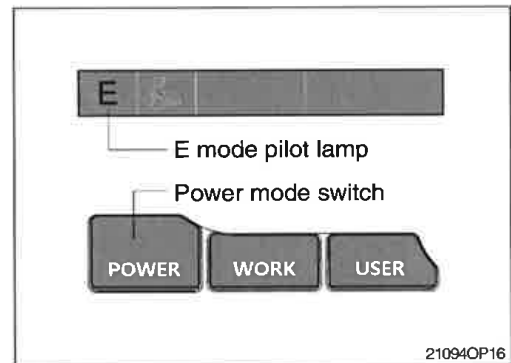

21094OP16

(2) S mode

The accel dial is set 10 and the auto idle mode is canceled.

Engine rpm	Effect
1750 ± 50	Standard power

* When the accel dial is located below 9 the engine speed decreases about 50~100 rpm per dial set.

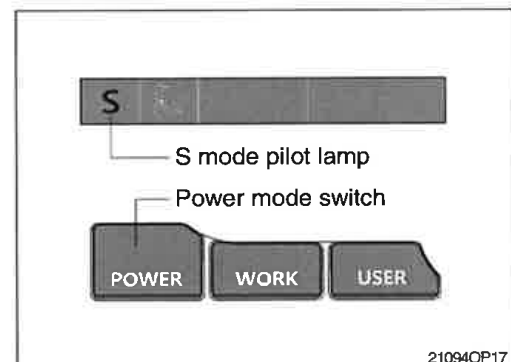

21094OP17



(3) P mode

The accel dial is set 10 and the auto idle mode is canceled.

Engine rpm	Effect
1950 ± 50	Approximately 120 % of power and speed available than S mode.

※ When the accel dial is located below 9 the engine speed decreases about 50~100 rpm per dial set.

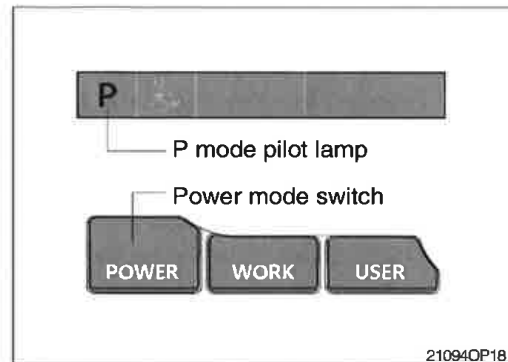

5. OPERATION OF THE WORKING DEVICE

※ Confirm the operation of control lever and working device.

- 1) Left control lever controls arm and swing.
- 2) Right control lever controls boom and bucket.
- 3) When you release the control lever, control lever returns to neutral position automatically.

※ When operating swing, consider the swing distance by inertia.

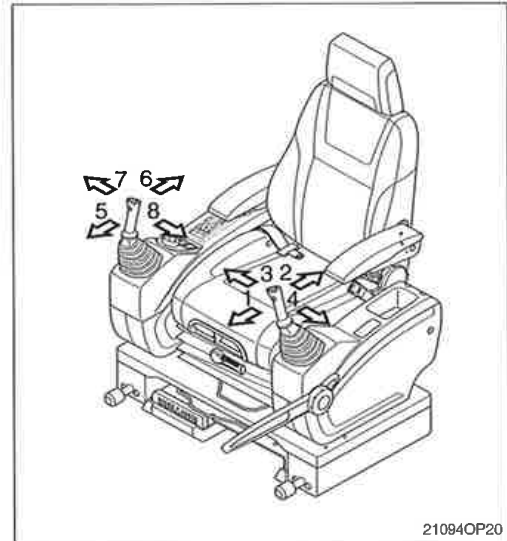

※ Left control lever

- 1 Arm roll-out
- 2 Arm roll-in
- 3 Swing right
- 4 Swing left

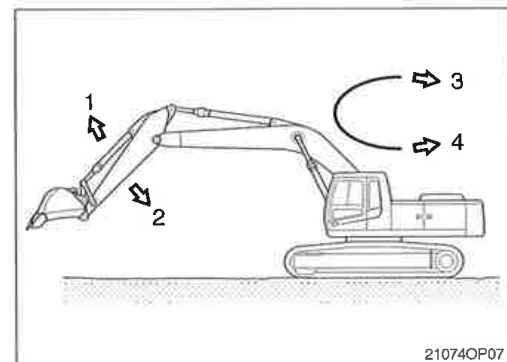

※ Right control lever

- 5 Boom lower
- 6 Boom raise
- 7 Bucket roll-out
- 8 Bucket roll-in

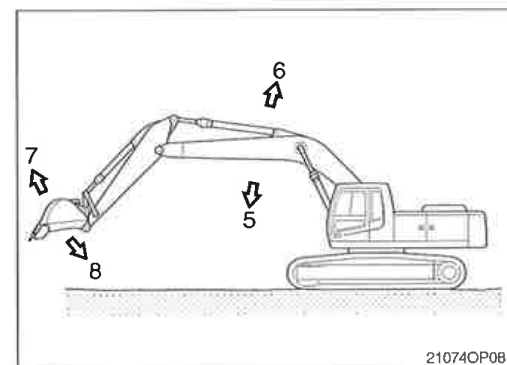

6. TRAVELING OF THE MACHINE

1) BASIC OPERATION

(1) Traveling position

It is the position which the traveling motor is in the rear and the working device is forward.

- ▲ Be careful as the traveling direction will be reversed when the whole machine is swung 180 degree.

(2) Traveling operation

It is possible to travel by either travel lever or pedal.

- ※ Do not travel continuously for a long time.
- ※ Reduce the engine speed and travel at a low speed when traveling on uneven ground.

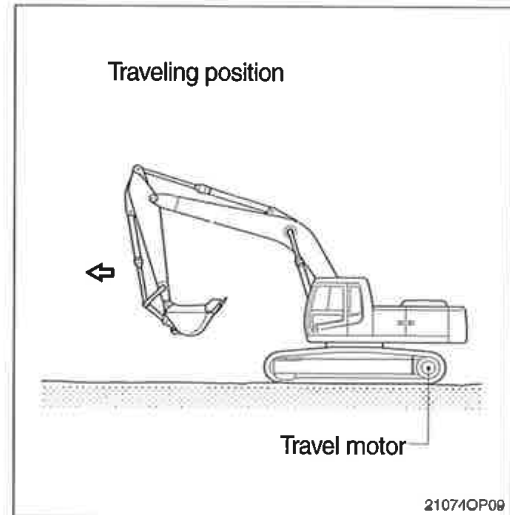

(3) Forward and backward traveling

When the left and right travel lever or pedal are pushed at the same time, the machine will travel forward or backward.

- ※ The speed can be controlled by the operation stroke of lever or pedal and change of direction will be controlled by difference of the left and right stroke.

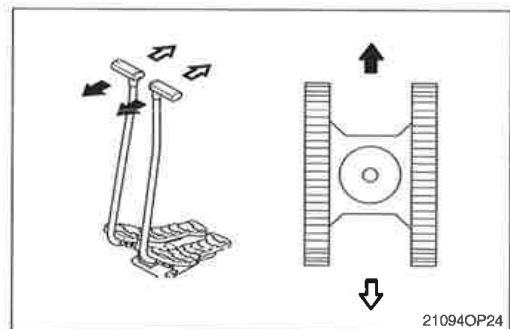

(4) Pivot turning

Operating only one side of lever or pedal make the change of direction possible by moving only one track.

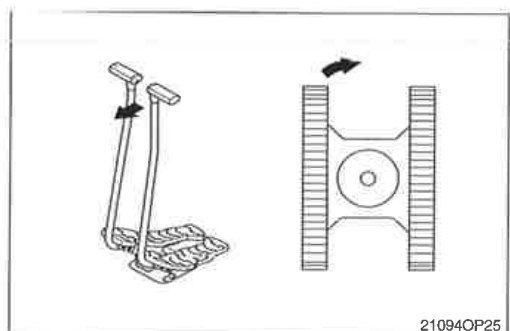

(5) Counter rotation

It is to change the direction at the original place by moving the right and left track. Both side of lever or pedal are operated to the other way at the same time.

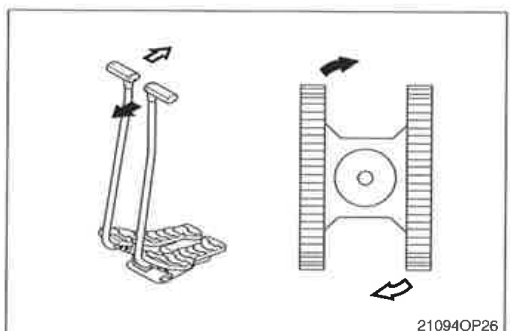



2) TRAVELING ON A SLOPE

- (1) Make sure that the travel lever is properly maneuvered by confirming the travel motor is in the right location.
 - (2) Lower the bucket 20 to 30 cm (1 ft) to the ground so that it can be used as a brake in an emergency.
 - (3) If the machine starts to slide or loses stability, lower the bucket immediately and brake the machine.
 - (4) When parking on a slope, use the bucket as a brake and place blocks behind the tracks to prevent sliding.
- ※ Machine cannot travel effectively on a slope when the oil temperature is low. Do the warming-up operation when it is going to travel on a slope.
 - ⚠ Be careful when working on slopes. It may cause the machine to lose its balance and turn over.
 - ⚠ Be sure to keep the travel speed switch on the LOW (turtle mark) while traveling on a slope.

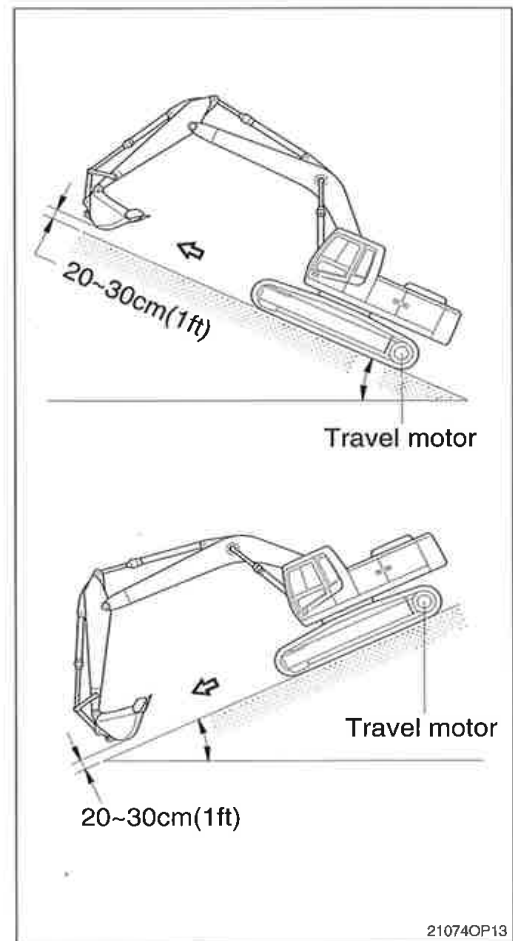

3) TRAVELING ON SOFT GROUND

- ※ If possible, avoid to operate on soft ground.
- (1) Move forward as far as machine can move.
 - (2) Take care not to go beyond the depth where towing is impossible on soft ground.
 - (3) When driving becomes impossible, lower bucket and use boom and arm to pull the machine. Operate boom, arm, and travel lever at the same time to avoid the machine sinking.

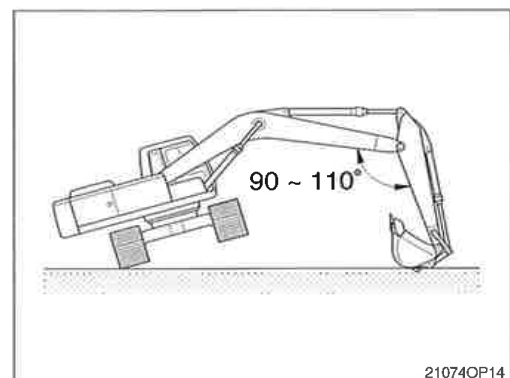



4) TOWING THE MACHINE

Tow the machine as follows when it can not move on it's own.

- (1) Tow the machine by other machine after hook the wire rope to the frame as shown in picture at right.
 - (2) Hook the wire rope to the frame and put a support under each part of wire rope to prevent damage.
- ※ **Never tow the machine using only the tie hole, because this may break.**
 - ⚠ **Make sure no personnel are standing close to the tow rope.**

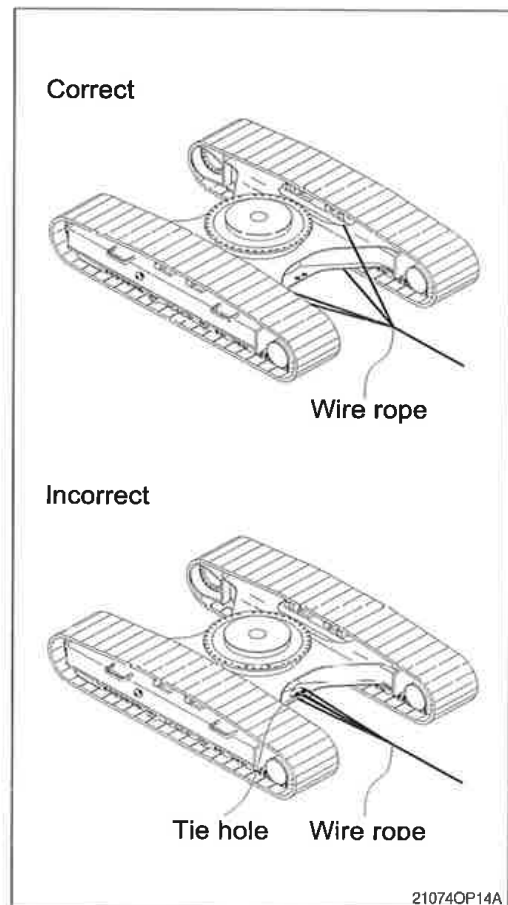

7. EFFICIENT WORKING METHOD

- 1) Do the digging work by arm.

Use the pulling force of arm for digging and use together with the digging force of the bucket if necessary.

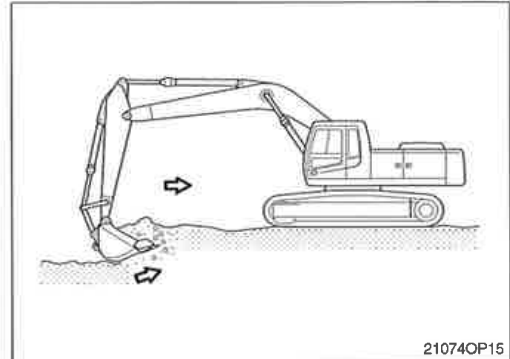

- 2) When lowering and raising the boom operate softly for the beginning and the end. In particularly, sudden stops while lowering the boom may cause damage to the machine.

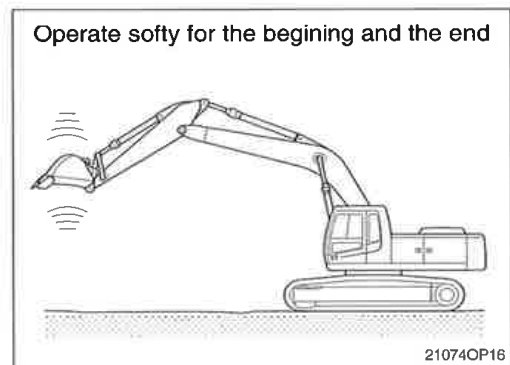

- 3) The digging resistance and wearing of tooth can be reduced by putting the end of bucket tooth to the digging direction.

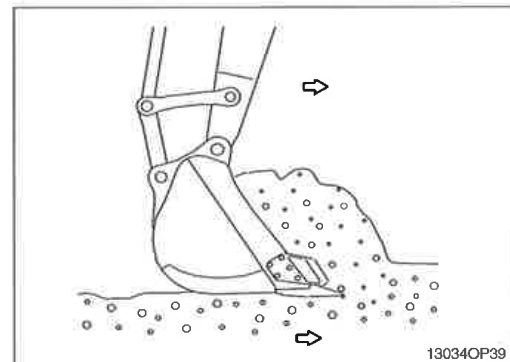

- 4) Set the tracks parallel to the line of the ditch to be excavated when digging ditch. Do not swing while digging.

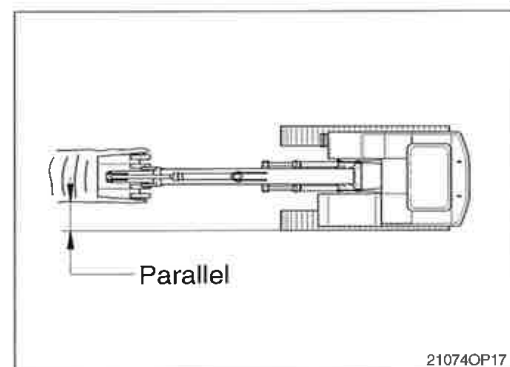

- 5) Dig slowly with keeping the angle of boom and arm, 90-110 degree when maximum digging force is required.

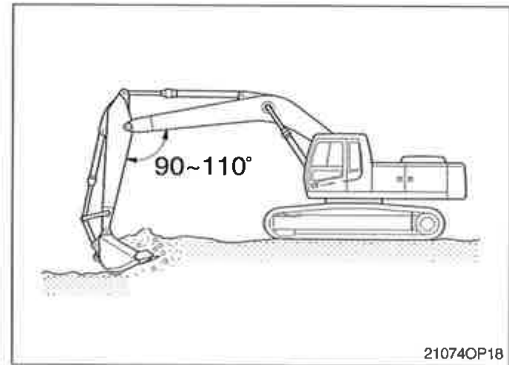

- 6) Operate leaving a small safety margin of cylinder stroke to prevent damage of cylinder when working with the machine.

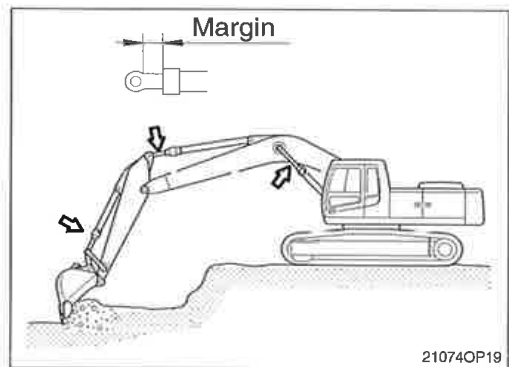

- 7) Keep the bucket to the dumping position and the arm horizontal when dumping the soil from the bucket.

Operate bucket lever 2 or 3 times when hard to dump.

- ※ Do not use the impact of bucket tooth when dumping.

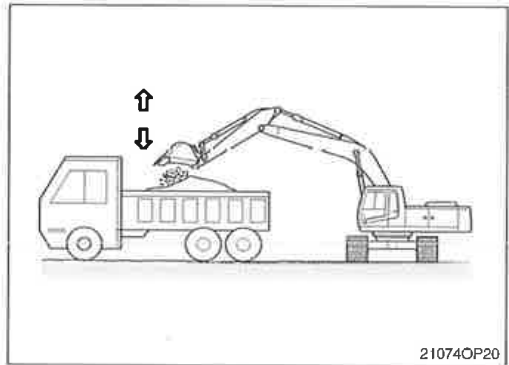

- 8) Operate stop of swing considering the swing slip distance is created by inertia after neutralizing the swing lever.

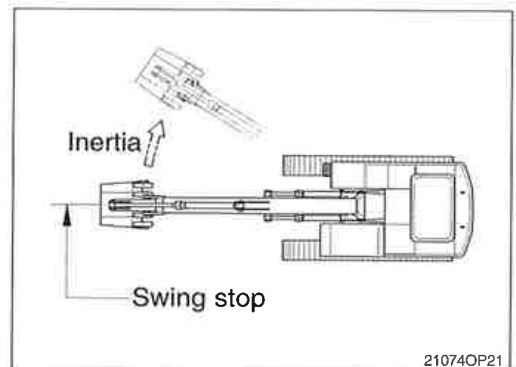

- 9) Do not use the dropping force of the work equipment for digging.
The machine can be damaged by the impact.

Incorrect

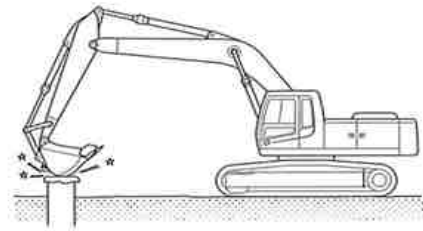

21074OP22

- 10) Do not use the bucket to crack hard objects like concrete or rocks.
This may break a tooth or pin, or bend boom.

Incorrect

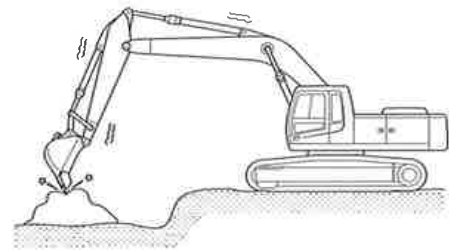

21074OP23

- 11) **NEVER CARRY OUT EXCESSIVE OPERATIONS**
Operation exceeding machine performance may result in accident or failure.
Carry out lifting operation within specified load limit.
Never carry out operations which may damage the machine such as overload or over-impact-load.
Never travel while carrying a load.
In case you need installing over load warning device for object handling procedure, please contact Hyundai distributor.

Incorrect

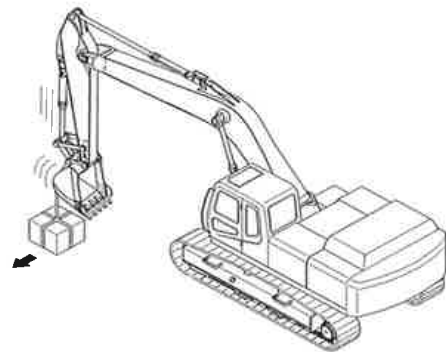

Incorrect

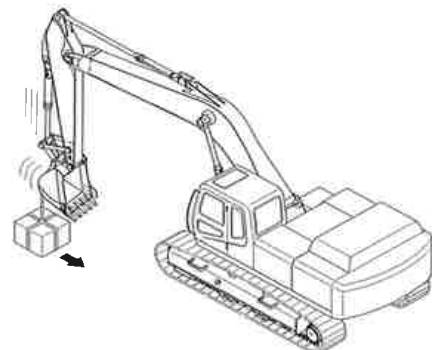

29074OP35

12) BUCKET WITH HOOK

When carrying out lifting work, the special lifting hook is necessary.

The following operations are prohibited.

- Lifting loads with a wire rope fitted around the bucket teeth.
- Lifting loads with the wire rope wrapped directly around the boom or arm.

When performing lifting operation, securely hook the wire rope onto the special lifting hook.

When performing lifting operation, never raise or lower a person.

Due to the possible danger of the load falling or of collision with the load, no persons shall be allowed in the working area.

Before performing lifting operation, designate an operation supervisor.

Always execute operation according to his instructions.

- Execute operating methods and procedures under his direction.
- Select a person responsible for signaling. Operate only on signals given by such person.

Never leave the operator's seat while lifting a load.

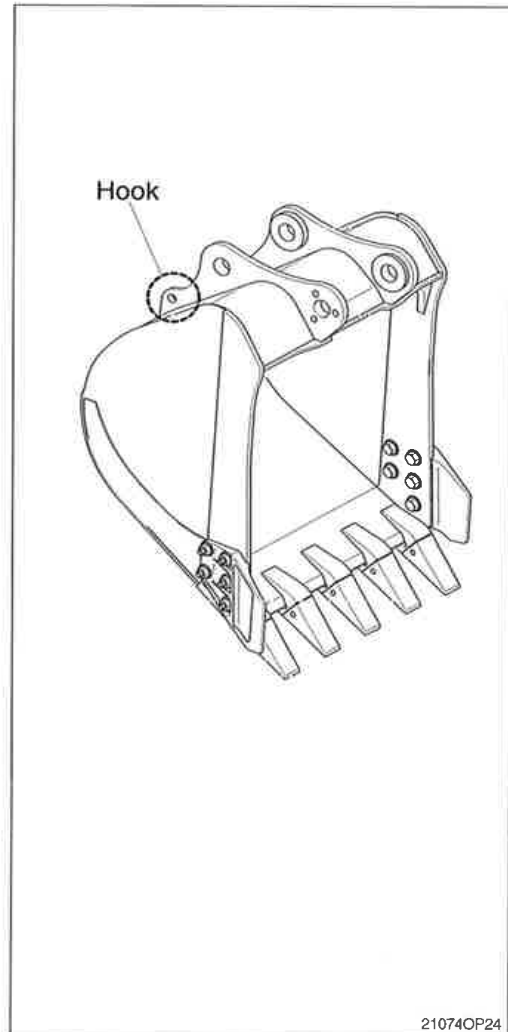

21074OP24



8. OPERATION IN THE SPECIAL WORK SITES

1) OPERATION THE MACHINE IN A COLD WEATHER

- (1) Use proper engine oil and fuel for the weather.
- (2) Fill the required amount of antifreeze in the coolant.
- (3) Refer to the starting engine in cold weather.
Start the engine and extend the warming up operation.
- (4) Be sure to open the heater cock when using the heater.
- (5) Always keep the battery completely charged.
* Discharged batteries will freeze more easily than fully charged.
- (6) Clean the machine and park on the wood plates.

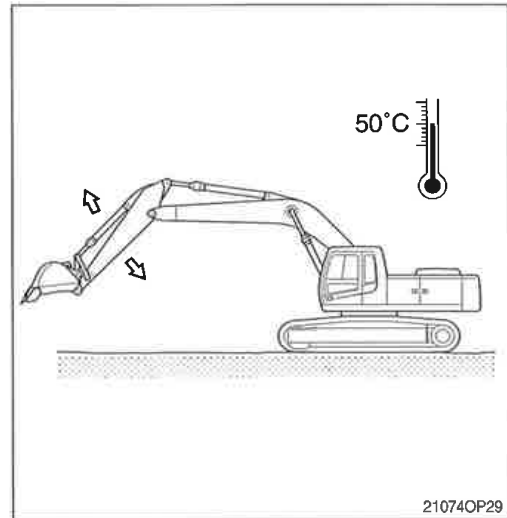

2) OPERATION IN SANDY OR DUSTY WORK SITES

- (1) Inspect air cleaner element frequently. Clean or replace element more frequently, if warning lamp comes ON and buzzer sounds simultaneously, regardless of inspection period.
* Replace the inner and outer element after 6 times of cleaning.
- (2) Inspect radiator frequently, and keep cooling fins clean.
- (3) Prevent sand or dust from getting into fuel tank and hydraulic tank during refilling.
- (4) Prevent sand or dust from penetrating into hydraulic circuit by tightly closing breather cap of hydraulic oil tank. Replace hydraulic oil filter and air breather element frequently.
- (5) Keep all lubricated part, such as pins and bushings, clean at all times.
- (6) If the air conditioner and heater filters clogged, the heating or cooling capacity will drop. Clean or replace the filter element more frequently.



3) SEA SHORE OPERATION

- (1) Prevent ingress of salt by securely tightening plugs, cocks and bolts of each part.
- (2) Wash machine after operation to remove salt residue.
Pay special attention to electrical parts, and hydraulic cylinders and track tension cylinder to prevent corrosion.
- (3) Inspection and lubrication must be carried out more frequently.
Supply sufficient grease to replace all old grease in bearings which have been submerged in water for a long time.

9. NORMAL OPERATION OF EXCAVATOR

Followings may occur during operation due to the nature of a hydraulic excavator.

- 1) When rolling in the arm, the roll-in movement stop momentary at point X in the picture shown, then recovers speed again after passing point X. The reason for this phenomenon is that movement by the arm weight is faster than the speed of oil flow into the cylinder.
- 2) When lowering the boom, one may hear continuous sound. This is caused by oil flow in the valve.
- 3) Overloaded movement will produce sound caused by the relief valves, which are for the protection of the hydraulic systems.
- 4) When the machine is started swing or stopped, a noise near the swing motor may be heard. The noise is generated when the brake valve relieves.

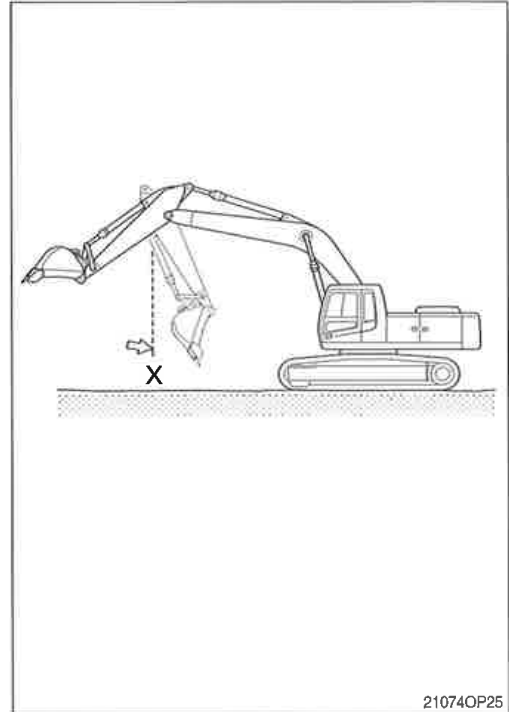

21074OP25

10. ATTACHMENT LOWERING (when engine is stopped)

1) On machines equipped with an accumulator, for a short time (within 1 minute) after the engine is stopped, the attachment will lower under its own weight when the attachment control lever is shifted to LOWER. That is happen only starting switch ON position and safety lever UNLOCK position. After the engine is stopped, set the safety lever to the LOCK position.

⚠ Be sure no one is under or near the attachment before lowering the boom.

2) The accumulator is filled with high-pressure nitrogen gas, and it is extremely dangerous if it is handled in the wrong way. Always observe the following precautions.

⚠ Never make any hole in the accumulator expose it to flame or fire.

⚠ Do not weld anything to the accumulator.

※ When carrying out disassembly or maintenance of the accumulator, or when disposing of the accumulator, it is necessary to release the gas from the accumulator.

A special air bleed valve is necessary for this operation, so please contact your Hyundai distributor.

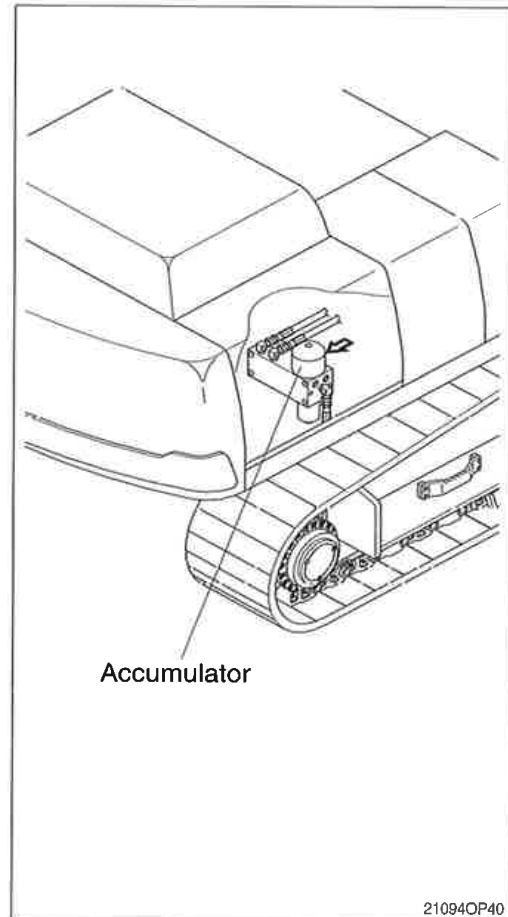

21094OP40



11. STORAGE

Maintain the machine taking care of following to prevent the deterioration of machine when storing the machine for a long time, over 1 month.

1) CLEANING THE MACHINE

Clean the machine. Check and adjust tracks.
Grease each lubrication part.

2) LUBRICATION POSITION OF EACH PART

Change all oil.

※ Be particularly careful when you reuse the machine.

As oil can be diluted during storage.

Apply an anticorrosive lubricant on the exposed part of piston rod of cylinder and in places where the machine rusts easily.

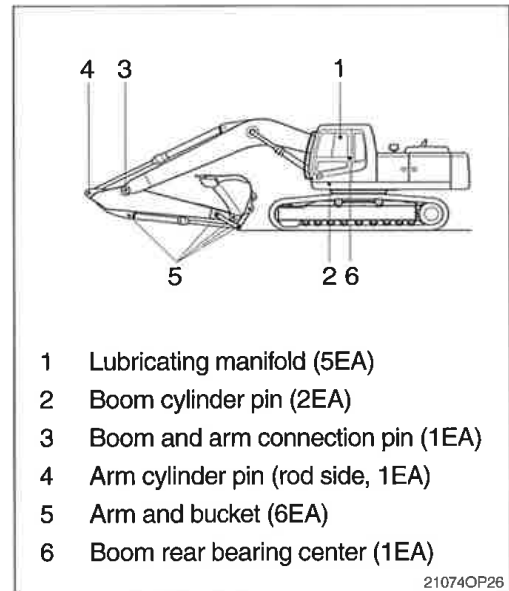

3) MASTER SWITCH

Turn OFF the master switch mounted electric box and store the machine.

4) Be sure to mix anticorrosive antifreezing solution in the radiator.

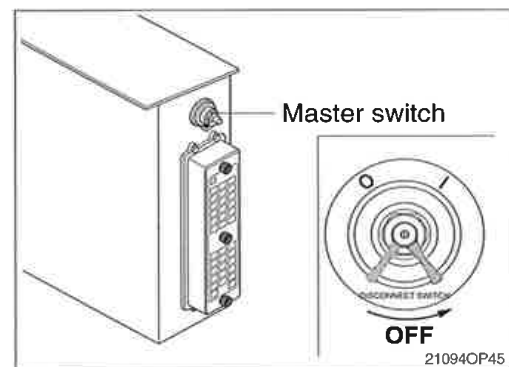

5) PREVENTION OF DUST AND MOISTURE

Keep machine dry. Store the machine setting wood on the ground.

※ Cover exposed part of piston rod of cylinder.

※ Lower the bucket to the ground and set a support under track.

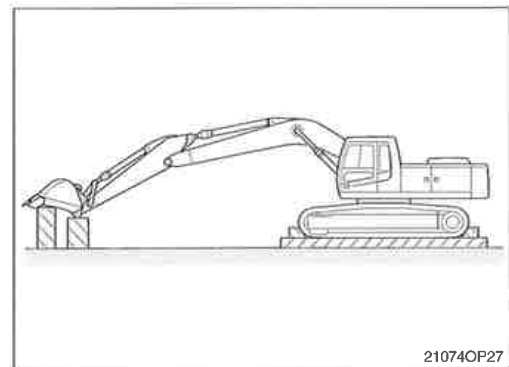



6) DURING STORAGE

Start engine and move the machine and work equipment once a month and apply lubrication to each part.

- ※ Check the level of engine oil and coolant and fill if required when starting engine.
- ※ Clean the anticorrosive on the piston rod of cylinder.
- ※ Operate the machine such as traveling, swing and work equipment operation to make sure enough lubrication of all functional components.

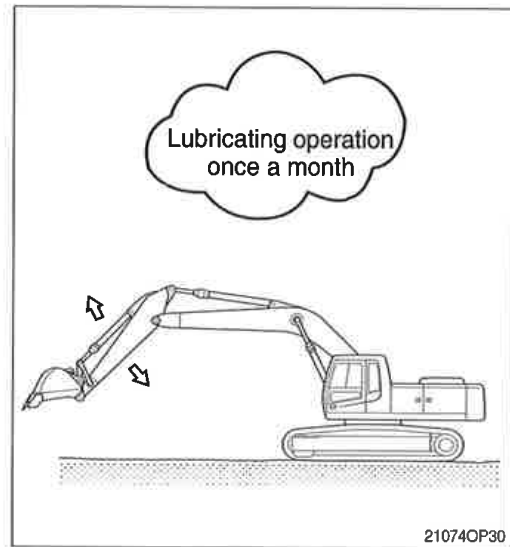



12. RCV LEVER OPERATING PATTERN

1) PATTERN CHANGE VALVE NOT INSTALL (standard)

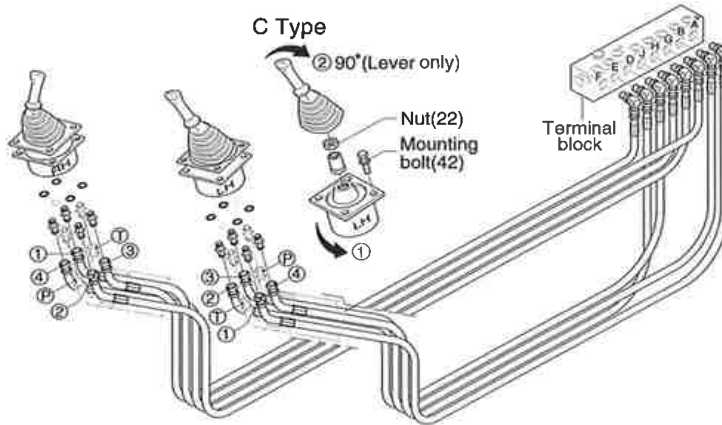

※ Whenever a change is made to the machine control pattern also exchange the pattern label in the cab to match the new pattern.

210940P50

Pattern	Operation		Control function	Hose connection (port)			
	Left RCV lever	Right RCV lever		RCV lever	From	To	
ISO Type			Left	1 Arm out	②	D	-
				2 Arm in	④	E	-
				3 Swing right	③	B	-
				4 Swing left	①	A	-
			Right	5 Boom lower	④	J	-
				6 Boom raise	②	H	-
				7 Bucket out	①	G	-
				8 Bucket in	③	F	-
Hyundai			Left	1 Boom lower	②	D	J
				2 Boom raise	④	E	H
				3 Swing right	③	B	-
				4 Swing left	①	A	-
			Right	5 Arm out	④	J	D
				6 Arm in	②	H	E
				7 Bucket out	①	G	-
				8 Bucket in	③	F	-
A Type			Left	1 Boom lower	②	D	J
				2 Boom raise	④	E	H
				3 Swing right	③	B	-
				4 Swing left	①	A	-
			Right	5 Arm out	④	J	D
				6 Arm in	②	H	E
				7 Bucket out	①	G	-
				8 Bucket in	③	F	-
B Type			Left	1 Boom lower	②	D	J
				2 Boom raise	④	E	H
				3 Bucket in	③	B	F
				4 Bucket out	①	A	G
			Right	5 Arm out	④	J	D
				6 Arm in	②	H	E
				7 Swing right	①	G	B
				8 Swing left	③	F	A
C Type			Left	① Loosen the RCV lever mounting bolt (42) and rotates lever assy 90° counterclockwise; then install. ② To put lever in correct position, disassemble nut (22) and rotates only lever 90° clockwise.			
			Right	Same as ISO type			



2) PATTERN CHANGE VALVE INSTALL (option)

- ※ If the machine is equipped with the pattern change valve, the machine operation pattern can be easily changed.
- ※ Whenever a change is made to the machine control pattern also exchange the pattern label in the cab to match the new pattern.

Operation	ISO type	A type	B type	C type
Left RCV lever				
Right RCV lever				

(1) The machine control pattern can be easily changed from the "ISO type" to "A type", "B type" or "C type" by changing the position of the lever position.

▲ Before starting the machine, check the lever position of pattern change valve and actual operating of attachment.

(2) Change of operating pattern

- ① Loosen the wing bolt.
- ② Move lever from the "ISO" type to "A", "B" or "C" type position.
- ③ After the lever is set, tighten the bolt in order to secure the lever.

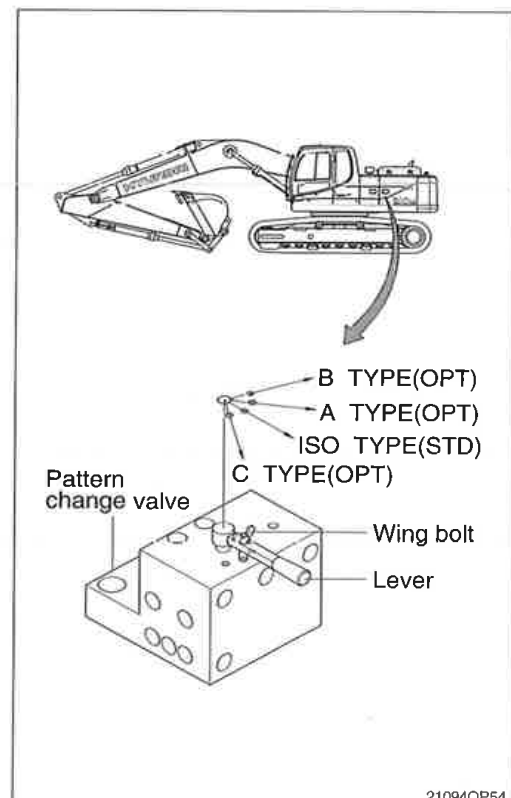

21094OP54



13. SWITCHING HYDRAULIC ATTACHMENT CIRCUIT

- 1) The combined hydraulic attachment circuit is capable of providing single action or double action.
- 2) The position of 3 way valve selects the single action hydraulic attachment circuit or the double action hydraulic attachment circuit.
- 3) Before you change the flow mode of hydraulic attachment circuit, place the machine in the servicing position as shown. Stop the engine.

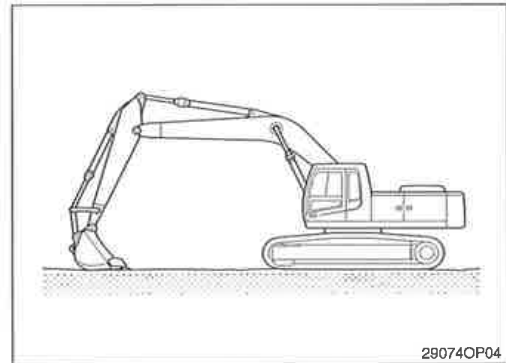

29074OP04

- 4) Use the spanner to turn the bolt of 3 way valve. Make sure that you turn the bolt between (b) and (c).
 - (1) One way flow (hydraulic breaker)
Position the groove parallel to the piping (b).
 - (2) Two way flow (clamshell or shear)
Position the groove perpendicular to the piping (c).

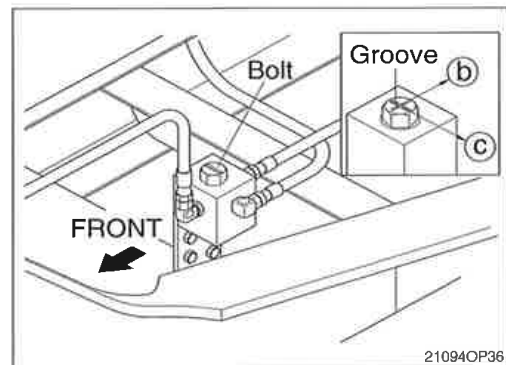

21094OP36





TRANSPORTATION

1. PREPARATION FOR TRANSPORTATION

- 1) When transporting the machine, observe the various road rules, road transportation vehicle laws and vehicle limit ordinances, etc.
- 2) Select proper trailer after confirming the weight and dimension from the chapter 2, specification.
- 3) Check the whole route such as the road width, the height of bridge and limit of weight and etc., which will be passed.
- 4) Get the permission from the related authority if necessary.
- 5) Prepare suitable capacity of trailer to support the machine.
- 6) Prepare gangplank for safe loading referring to the below table and illustration.

A	B
1.0	3.65 ~ 3.85
1.1	4.00 ~ 4.25
1.2	4.35 ~ 4.60
1.3	4.75 ~ 5.00
1.4	5.10 ~ 5.40
1.5	5.50 ~ 5.75

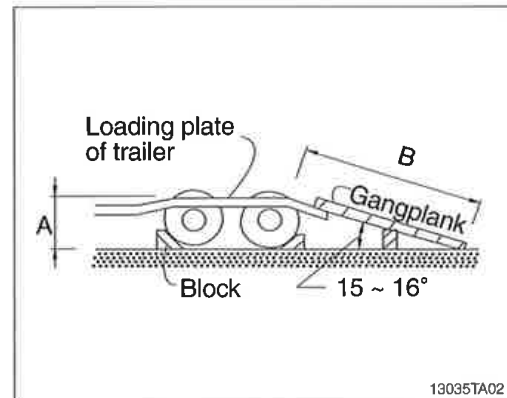
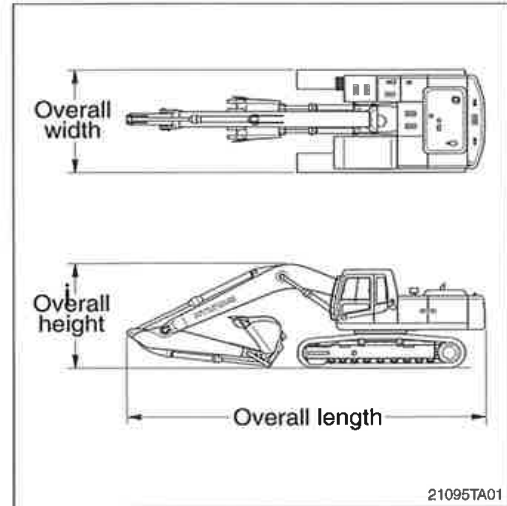



2. DIMENSION AND WEIGHT

1) R210LC-9

(1) Base machine

Mark	Description	Unit	Specification
L	Length	mm (ft-in)	4990 (16' 4")
H	Height	mm (ft-in)	2920 (9' 7")
W	Width	mm (ft-in)	2990 (9' 10")
Wt	Weight	kg (lb)	17610 (38820)

※ With 600 mm (24") triple grouser shoes and 3800 kg (8380 lb) counterweight.

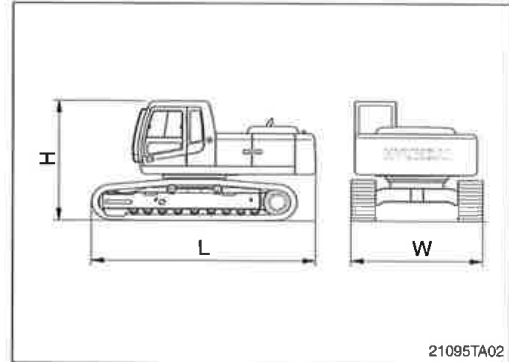

(2) Boom assembly

Mark	Description	Unit	Specification
L	Length	mm (ft-in)	5900 (19' 4")
H	Height	mm (ft-in)	1550 (5' 1")
W	Width	mm (ft-in)	700 (2' 4")
Wt	Weight	kg (lb)	1950 (4300)

※ 5.68 m (18' 8") boom with arm cylinder (included piping and pins).

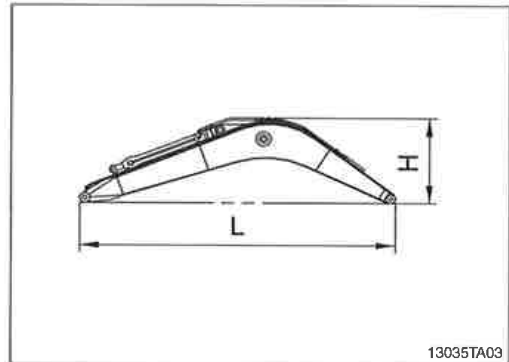

(3) Arm assembly

Mark	Description	Unit	Specification
L	Length	mm (ft-in)	3910 (12'10")
H	Height	mm (ft-in)	870 (2' 10")
W	Width	mm (ft-in)	350 (1' 2")
Wt	Weight	kg (lb)	1095 (2410)

※ 2.92 m (9' 7") arm with bucket cylinder (included linkage and pins).

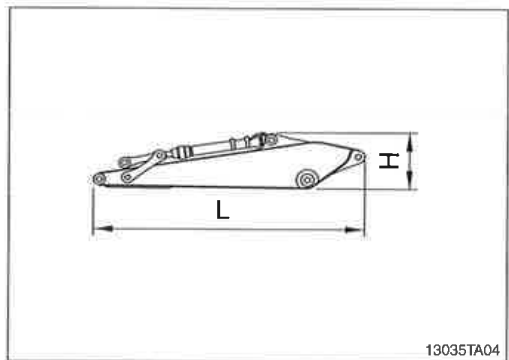

(4) Bucket assembly

Mark	Description	Unit	Specification
L	Length	mm (ft-in)	1600 (5' 3")
H	Height	mm (ft-in)	980 (3' 3")
W	Width	mm (ft-in)	1270 (4' 2")
Wt	Weight	kg (lb)	765 (1690)

※ 0.92 m³ (1.20 yd³) SAE heaped bucket (included tooth and side cutters).

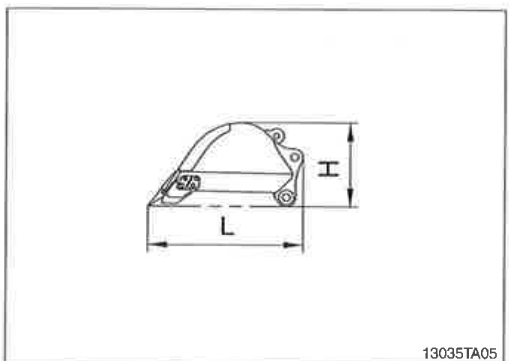



(5) Boom cylinder

Mark	Description	Unit	Specification
L	Length	mm (ft-in)	1960 (6' 5")
H	Height	mm (ft-in)	230 (0' 9")
W	Width	mm (ft-in)	330 (1' 1")
Wt	Weight	kg (lb)	380 (840)

※ Included piping.

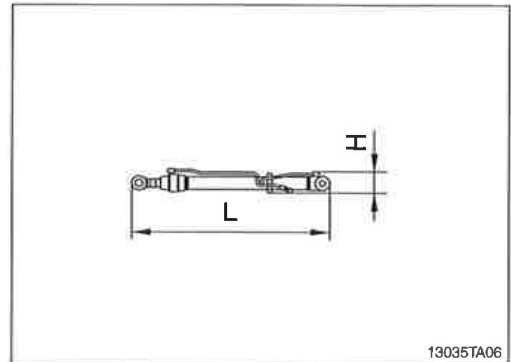

(6) Cab assembly

Mark	Description	Unit	Specification
L	Length	mm (ft-in)	1962 (6' 4")
H	Height	mm (ft-in)	1676 (5' 5")
W	Width	mm (ft-in)	1288 (4' 2")
Wt	Weight	kg (lb)	310 (680)

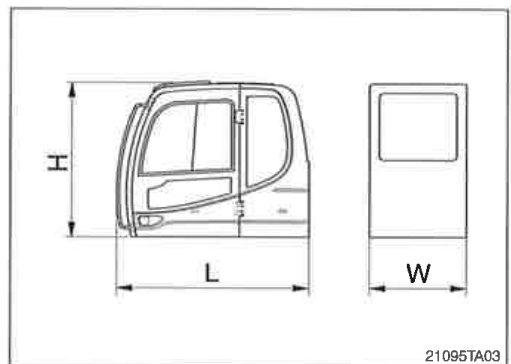

(7) Counterweight

Mark	Description	Unit	Specification
L	Length	mm (ft-in)	2740 (9' 0")
H	Height	mm (ft-in)	1162 (3' 10")
W	Width	mm (ft-in)	560 (1' 10")
Wt	Weight	kg (lb)	3800 (8380)

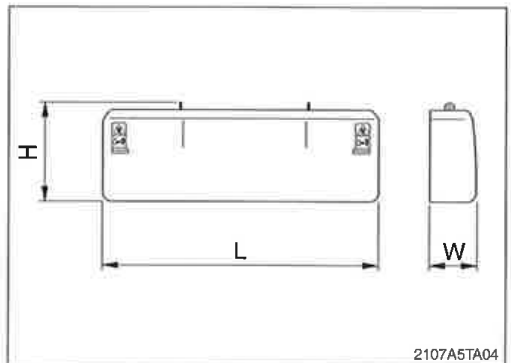



2) R210LC-9 LONG REACH

(1) Base machine

Mark	Description	Unit	Specification
L	Length	mm (ft-in)	4990 (16' 4")
H	Height	mm (ft-in)	2920 (9' 7")
W	Width	mm (ft-in)	3190 (10' 6")
Wt	Weight	kg (lb)	18380 (40520)

※ With 800 mm (32") triple grouser shoes and 5300 kg (11680 lb) counterweight.

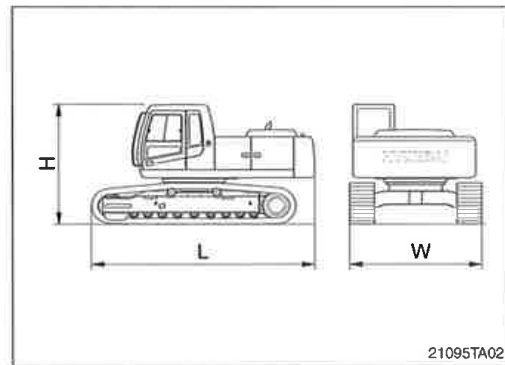

(2) Boom assembly

Mark	Description	Unit	Specification
L	Length	mm (ft-in)	8395 (27' 7")
H	Height	mm (ft-in)	1515 (5' 0")
W	Width	mm (ft-in)	800 (2' 7")
Wt	Weight	kg (lb)	2470 (5450)

※ 8.2 m (26' 11") boom with arm cylinder (included piping and pins).

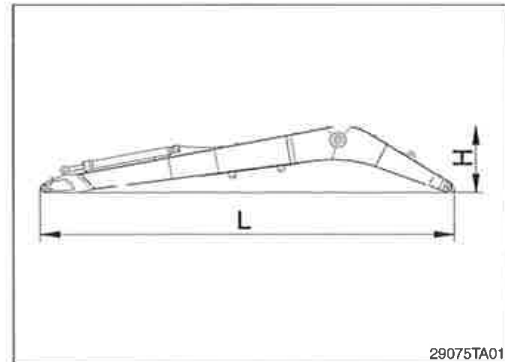

(3) Arm assembly

Mark	Description	Unit	Specification
L	Length	mm (ft-in)	7280 (23' 11")
H	Height	mm (ft-in)	835 (12' 9")
W	Width	mm (ft-in)	480 (1' 7")
Wt	Weight	kg (lb)	1340 (2960)

※ 6.3 m (20' 8") arm with bucket cylinder (included linkage and pins).

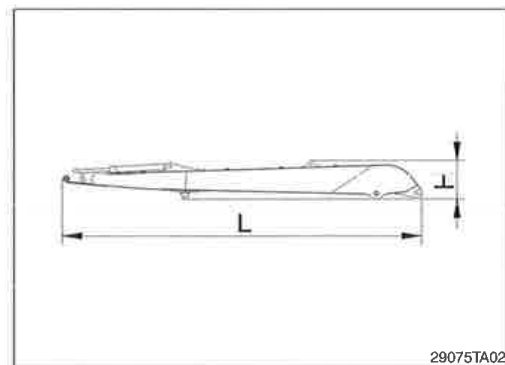

(4) Bucket assembly

Mark	Description	Unit	Specification
L	Length	mm (ft-in)	1600 (5' 3")
H	Height	mm (ft-in)	980 (3' 3")
W	Width	mm (ft-in)	820 (2' 8")
Wt	Weight	kg (lb)	465 (1030)

※ 0.52 m³ (0.68 yd³) SAE heaped bucket (included tooth and side cutters).

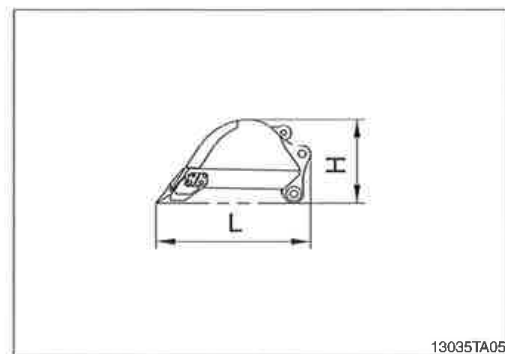



(5) Counterweight

Mark	Description	Unit	Specification
L	Length	mm (ft-in)	2740 (9' 0")
H	Height	mm (ft-in)	1162 (3' 10")
W	Width	mm (ft-in)	560 (1' 10")
Wt	Weight	kg (lb)	5300 (11680)

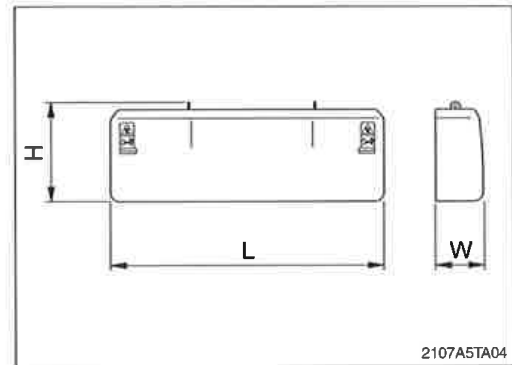

3) R210LC-9 HIGH WALKER

(1) Base machine

Mark	Description	Unit	Specification
L	Length	mm (ft-in)	4990 (16' 4")
H	Height	mm (ft-in)	3100 (10' 2")
W	Width	mm (ft-in)	3395 (11' 2")
Wt	Weight	kg (lb)	19260 (42460)

* With 600 mm (24") triple grouser shoes and 3800 kg (8380 lb) counterweight.

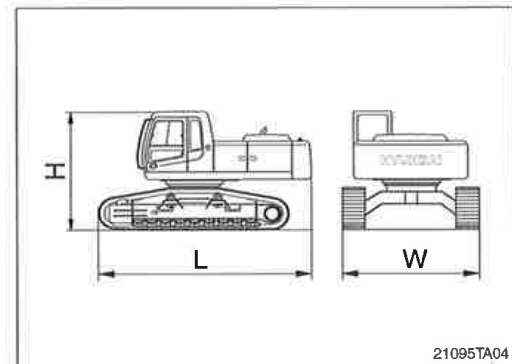



3. LOADING THE MACHINE

- 1) Load and unload the machine on a flat ground.
- 2) Use the gangplank with sufficient length, width, thickness and gradient.
- 3) Place the swing lock lever to the LOCK position before fixing the machine at the bed of trailer and confirm if the machine parallels the bed of trailer. Keep the travel motor in the rear when loading and in the front when unloading.

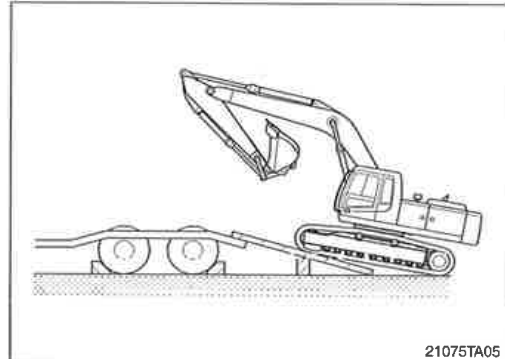

- 4) Do the following after loading the machine to the trailer.

- (1) Stop loading when the machine is located horizontally with the rear wheel of trailer.

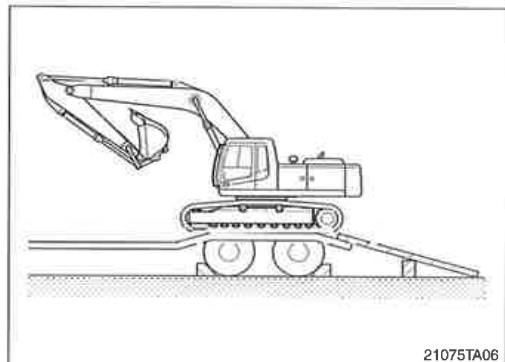

- (2) Place the swing lock lever to the LOCK position after the swing the machine 180 degree.

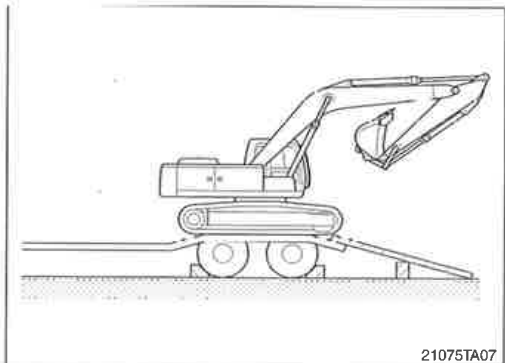

(3) Lower the working equipment gently after the location is determined.

※ Place rectangular timber under the bucket cylinder to prevent the damage of it during transportation.

▲ Be sure to keep the travel speed switch on the LOW (turtle mark) while loading and unloading the machine.

▲ Avoid using the working equipment for loading and unloading since it will be very dangerous.

▲ Do not operate any other device when loading.

▲ Be careful on the boundary place of loading plate or trailer as the balance of machine will abruptly be changed on the point.

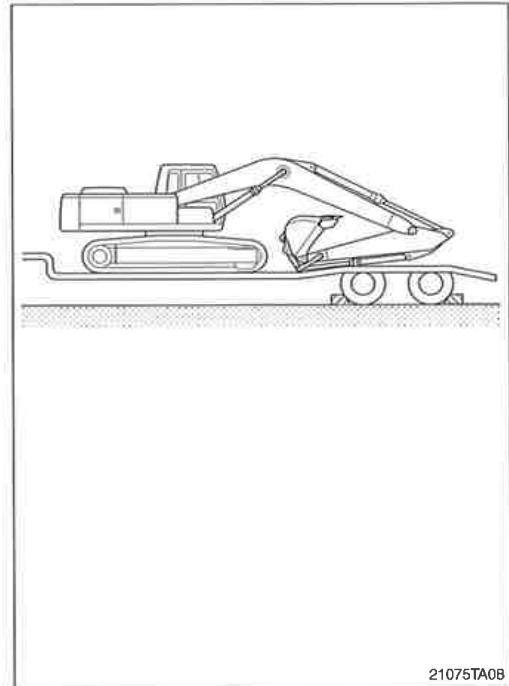

21075TA08

▲ The machine with long reach attachments should be moved or transmitted with boom and arm fixed using stay.

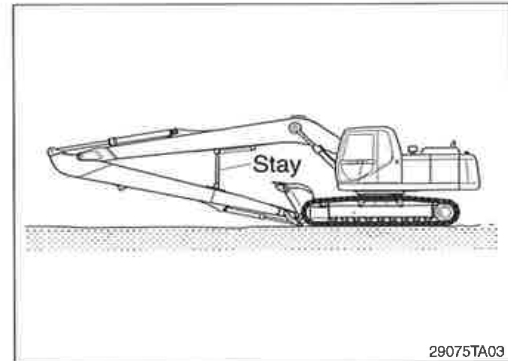

29075TA03

5) Fix method of stay bracket

- (1) Extend arm cylinder to maximum.
- (2) Mark on the rod of 5~7 mm distance from tube end.
- (3) Retract the arm cylinder to the mark.
- (4) Adjust the stay bracket and then fix the stay to the proper location.

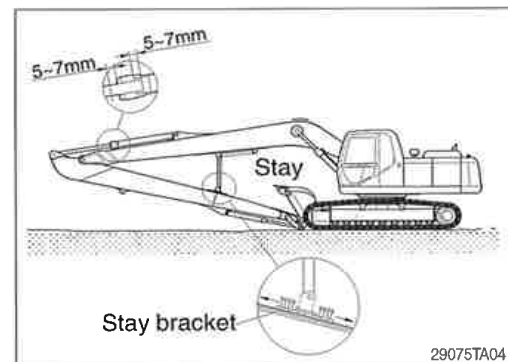

29075TA04

4. FIXING THE MACHINE

- 1) Lower down the working device on the loading plate of trailer.
- 2) Keep the safety lever on the LOCK position.
- 3) Turn OFF all the switches and remove the key.

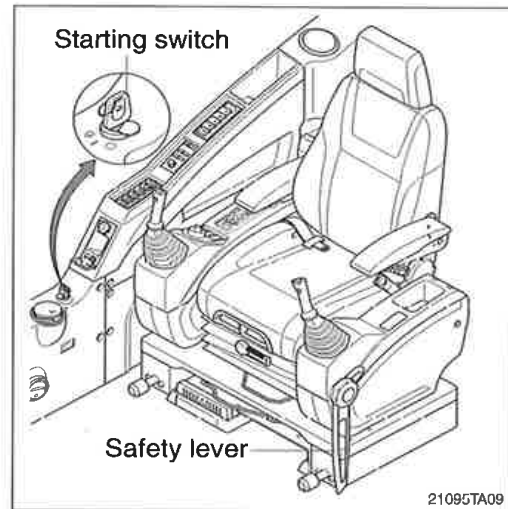

- 4) Secure all locks.

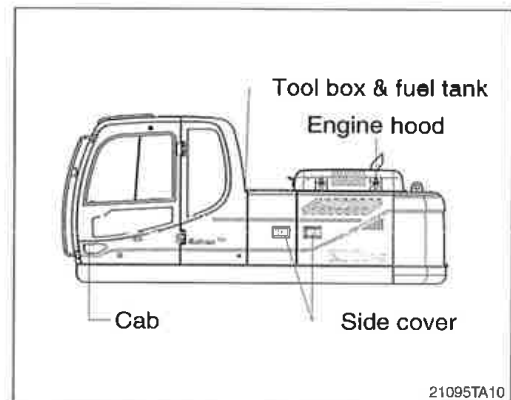

- 5) Place timber underneath of the track and fix firmly with wire rope to prevent the machine from moving forward, backward, right or left.

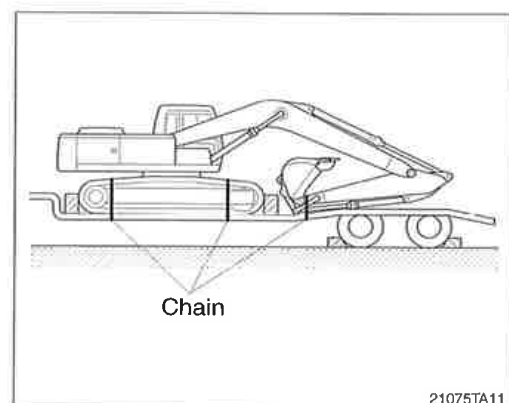

5. LOADING AND UNLOADING BY CRANE

- 1) Check the weight, length, width and height of the machine referring to the chapter 2, specification when you are going to hoist the machine.
 - 2) Use long wire rope and stay to keep the distance with the machine as it should avoid touching with the machine.
 - 3) Put a rubber plate contact with wire rope and machine to prevent damage.
 - 4) Place crane on the proper place.
 - 5) Install the wire rope and stay like the illustration.
- ▲ Make sure wire rope is proper size.
 - ▲ Place the safety lever to LOCK position to prevent the machine moving when hoisting the machine.
 - ▲ The wrong hoisting method or installation of wire rope can cause damage to the machine.
 - ▲ Do not load abruptly.
 - ▲ Keep area clear of personnel.

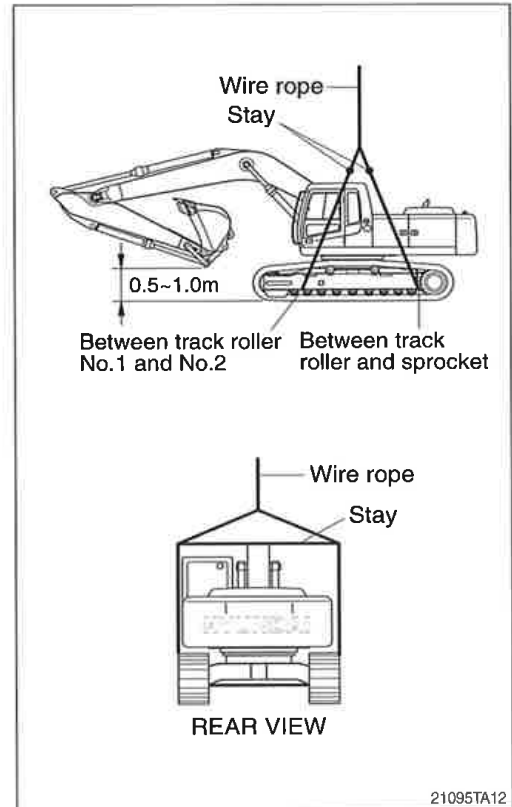





MAINTENANCE

1. INSTRUCTION

1) INTERVAL OF MAINTENANCE

- (1) You may inspect and service the machine by the period as described at page 6-11 based on hour meter at control panel.
- (2) Shorten the interval of inspect and service depending on site condition. (such as dusty area, quarry, sea shore and etc.)
- (3) Practice the entire related details at the same time when the service interval is doubled.
For example, in case of 100hours, carry out all the maintenance 「Each 100hours, each 50 hours and daily service」 at the same time.

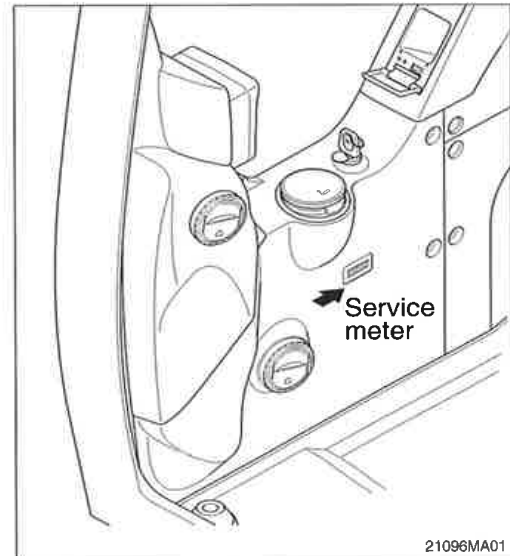

21096MA01

2) PRECAUTION

- (1) Start to maintenance after you have the full knowledge of machine.
- (2) The monitor installed on this machine does not entirely guarantee the condition of the machine. Daily inspection should be performed according to clause 4, maintenance check list.
- (3) Engine and hydraulic components have been preset in the factory.
Do not allow unauthorized personnel to reset them.
- (4) Ask to your local dealer or Hyundai for the maintenance advice if unknown.
- (5) Drain the used oil and coolant in a container and handle according to the method of handling for industrial waste to meet with regulations of each province or country.



3) PROPER MAINTENANCE

(1) Replace and repair of parts

It is required to replace the wearable and consumable parts such as bucket tooth, side cutter, filter and etc., regularly.

Replace damaged or worn parts at proper time to keep the performance of machine.

(2) Use genuine parts.

(3) Use the recommended oil.

(4) Remove the dust or water around the inlet of oil tank before supplying oil.

(5) Drain oil when the temperature of oil is warm.

(6) Do not repair anything while operating the engine.

Stop the engine when you fill the oil.

(7) Relieve hydraulic system of the pressure before repairing the hydraulic system.

(8) Confirm if the cluster is in the normal condition after completion of service.

(9) For more detail information of maintenance, please contact local Hyundai dealer.

※ **Be sure to start the maintenance after fully understand the chapter 1, safety hints.**



4) RELIEVING THE PRESSURE IN THE HYDRAULIC SYSTEM

※ Spouting of oil can cause the accident when loosening the cap or hose right after the operating of machine as the machine or oil is on the high pressure on the condition.
Be sure to relieve the pressure in the system before repairing hydraulic system.

- (1) Place machine in parking position, and stop the engine.

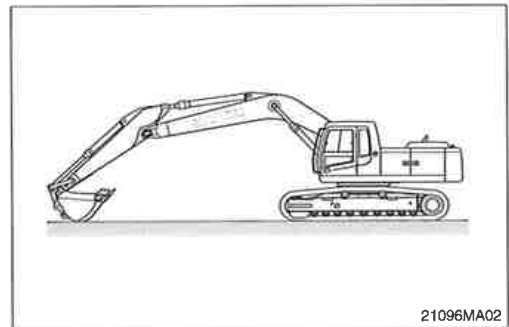

- (2) Set the safety lever completely in the release position, operate the control levers and pedals fully to the front, rear, left and right, to release the pressure in the hydraulic circuit.

※ This does not completely release the pressure, so when serving hydraulic component, loosen the connections slowly and do not stand in the direction where the oil spurt out.

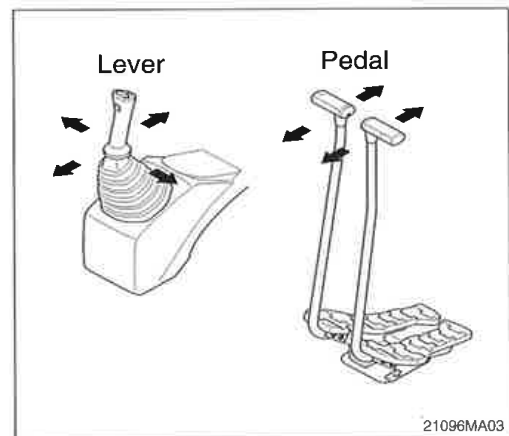

- (3) Loosen the cap and relieve the pressure in the tank by pushing the top of the air breather.

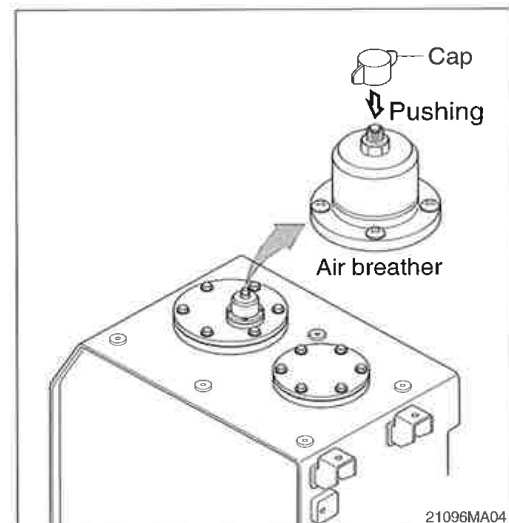



5) PRECAUTION WHEN INSTALLING HYDRAULIC HOSES OR PIPES

- (1) Be particularly careful that the joint of hose, pipe and functioning item are not damaged.
Avoid contamination.
- (2) Assemble after cleaning the hose, pipe and joint of functioning item.
- (3) Use genuine parts.
- (4) Do not assemble the hose in the condition of twisted or sharp radius.
- (5) Keep the specified tighten torque.



6) PERIODICAL REPLACEMENT OF SAFETY PARTS

(1) It is desirable to do periodic maintenance the machine for using the machine safely for a long time.

However, recommend to replace regularly the parts related safety not only safety but maintain satisfied performance.

(2) These parts can cause the disaster of life and material as the quality changes by passing time and it is worn, diluted, and gets fatigued by using repeatedly.

These are the parts which the operator can not judge the remained lifetime of them by visual inspection.

(3) Repair or replace if an abnormality of these parts is found even before the recommended replacement interval.

Periodical replacement of safety parts		Interval	
Engine	Fuel hose (tank-engine)	Every 2 years	
	Heater hose (heater-engine)		
Hydraulic system	Main circuit	Pump suction hose	Every 2 years
		Pump delivery hose	
		Swing hose	
	Working device	Boom cylinder line hose	Every 2 years
		Arm cylinder line hose	
		Bucket cylinder line hose	

- ※ 1. Replace O-ring and gasket at the same time when replacing the hose.
- 2. Replace clamp at the same time if the hose clamp is cracked when checking and replacing the hose.



2. TIGHTENING TORQUE

Use following table for unspecified torque.

1) BOLT AND NUT

(1) Coarse thread

Bolt size	8T		10T	
	kgf · m	lbf · ft	kgf · m	lbf · ft
M 6 × 1.0	0.9 ~ 1.3	6.5 ~ 9.4	1.1 ~ 1.7	8.0 ~ 12.3
M 8 × 1.25	2.0 ~ 3.0	14.5 ~ 21.7	2.7 ~ 4.1	19.5 ~ 29.7
M10 × 1.5	4.0 ~ 6.0	28.9 ~ 43.4	5.5 ~ 8.3	39.8 ~ 60.0
M12 × 1.75	7.4 ~ 11.2	53.5 ~ 81.0	9.8 ~ 15.8	70.9 ~ 114
M14 × 2.0	12.2 ~ 16.6	88.2 ~ 120	16.7 ~ 22.5	121 ~ 163
M16 × 2.0	18.6 ~ 25.2	135 ~ 182	25.2 ~ 34.2	182 ~ 247
M18 × 2.5	25.8 ~ 35.0	187 ~ 253	35.1 ~ 47.5	254 ~ 344
M20 × 2.5	36.2 ~ 49.0	262 ~ 354	49.2 ~ 66.6	356 ~ 482
M22 × 2.5	48.3 ~ 63.3	349 ~ 458	65.8 ~ 98.0	476 ~ 709
M24 × 3.0	62.5 ~ 84.5	452 ~ 611	85.0 ~ 115	615 ~ 832
M30 × 3.5	124 ~ 168	898 ~ 1214	169 ~ 229	1223 ~ 1656
M36 × 4.0	174 ~ 236	1261 ~ 1704	250 ~ 310	1808 ~ 2242

(2) Fine thread

Bolt size	8T		10T	
	kgf · m	lbf · ft	kgf · m	lbf · ft
M 8 × 1.0	2.2 ~ 3.4	15.9 ~ 24.6	3.0 ~ 4.4	21.7 ~ 31.8
M10 × 1.25	4.5 ~ 6.7	32.5 ~ 48.5	5.9 ~ 8.9	42.7 ~ 64.4
M12 × 1.25	7.8 ~ 11.6	56.4 ~ 83.9	10.6 ~ 16.0	76.7 ~ 116
M14 × 1.5	13.3 ~ 18.1	96.2 ~ 131	17.9 ~ 24.1	130 ~ 174
M16 × 1.5	19.9 ~ 26.9	144 ~ 195	26.6 ~ 36.0	192 ~ 260
M18 × 1.5	28.6 ~ 43.6	207 ~ 315	38.4 ~ 52.0	278 ~ 376
M20 × 1.5	40.0 ~ 54.0	289 ~ 391	53.4 ~ 72.2	386 ~ 522
M22 × 1.5	52.7 ~ 71.3	381 ~ 516	70.7 ~ 95.7	511 ~ 692
M24 × 2.0	67.9 ~ 91.9	491 ~ 665	90.9 ~ 123	658 ~ 890
M30 × 2.0	137 ~ 185	990 ~ 1339	182 ~ 248	1314 ~ 1796
M36 × 3.0	192 ~ 260	1390 ~ 1880	262 ~ 354	1894 ~ 2562



2) PIPE AND HOSE (FLARE type)

Thread size (PF)	Width across flat (mm)	kgf · m	lbf · ft
1/4"	19	4	28.9
3/8"	22	5	36.2
1/2"	27	9.5	68.7
3/4"	36	18	130.2
1"	41	21	151.9
1-1/4"	50	35	253.2

3) PIPE AND HOSE (ORFS type)

Thread size (UNF)	Width across flat (mm)	kgf · m	lbf · ft
9/16-18	19	4	28.9
11/16-16	22	5	36.2
13/16-16	27	9.5	68.7
1-3/16-12	36	18	130.2
1-7/16-12	41	21	151.9
1-11/16-12	50	35	253.2

4) FITTING

Thread size	Width across flat (mm)	kgf · m	lbf · ft
1/4"	19	4	28.9
3/8"	22	5	36.2
1/2"	27	9.5	68.7
3/4"	36	18	130.2
1"	41	21	151.9
1-1/4"	50	35	253.2



4) TIGHTENING TORQUE OF MAJOR COMPONENT

No.	Descriptions	Bolt size	Torque	
			kgf · m	lbf · ft
1	Engine mounting bolt (engine-bracket)	M12 × 1.75	12.8 ± 3.0	92.6 ± 21.7
2	Engine mounting bolt (eracket-frame, FR)	M20 × 2.5	55 ± 3.5	398 ± 25
3	Engine mounting bolt (eracket-frame, RR)	M24 × 3.0	97 ± 7.0	702 ± 51
4	Radiator mounting bolt	M16 × 2.0	29.7 ± 4.5	215 ± 32.5
5	Coupling mounting socket bolt	M18 × 2.5	32 ± 1.0	231 ± 7.2
6	Fuel tank mounting bolt	M20 × 2.5	46 ± 5.1	333 ± 36.9
7	Main pump housing mounting bolt	M10 × 1.5	4.8 ± 0.3	34.7 ± 2.2
8	Main pump mounting socket bolt	M20 × 2.5	42 ± 4.5	304 ± 32.5
9	Main control valve mounting nut	M12 × 1.75	12.3 ± 1.3	89.0 ± 9.4
10	Hydraulic oil tank mounting bolt	M20 × 2.5	46 ± 5.1	333 ± 36.9
11	Turning joint mounting bolt, nut	M12 × 1.75	12.3 ± 1.3	89.0 ± 9.4
12	Swing motor mounting bolt	M20 × 2.5	58.4 ± 6.4	422 ± 46.3
13	Swing bearing upper part mounting bolt	M20 × 2.5	57.8 ± 6.4	418 ± 46.3
14	Swing bearing lower part mounting bolt	M20 × 2.5	57.8 ± 6.4	418 ± 46.3
15	Travel motor mounting bolt	M16 × 2.0	23 ± 2.5	166 ± 18.1
16	Sprocket mounting bolt	M16 × 2.0	26 ± 2.5	188 ± 18.1
17	Carrier roller mounting bolt, nut	M16 × 2.0	29.7 ± 4.5	215 ± 32.5
18	Track roller mounting bolt	M16 × 2.0	29.7 ± 4.5	215 ± 32.5
19	Track tension cylinder mounting bolt	M16 × 2.0	29.7 ± 4.5	215 ± 32.5
20	Track shoe mounting bolt, nut	M20 × 1.5	78 ± 8.0	564 ± 57.9
21	Track guard mounting bolt	M20 × 2.5	57.9 ± 8.7	419 ± 62.9
22	Counterweight mounting bolt	M36 × 3.0	340 ± 10	2460 ± 72.3
23	Cab mounting bolt	M12 × 1.75	12.8 ± 3.0	92.6 ± 21.7
24	Operator's seat mounting bolt	M 8 × 1.25	4.05 ± 0.8	29.3 ± 5.8

※ For tightening torque of engine and hydraulic components, see engine maintenance guide and service manual.



3. FUEL, COOLANT AND LUBRICANTS

1) NEW MACHINE

New machine used and filled with following lubricants.

Description	Specification
Engine oil	SAE 15W-40 (API CH-4)
Hydraulic oil	ISO VG 46 (SAE 10W)
Swing and travel reduction gear	SAE 85W-140 (API GL-5)
Grease	Lithium base grease NLGI No. 2
Fuel	ASTM D975-No. 2
Coolant	Mixture of 50% ethylene glycol base antifreeze and 50% water.

SAE : Society of Automotive Engineers

API : American Petroleum Institute

ISO : International Organization for Standardization

NLGI : National Lubricating Grease Institute

ASTM : American Society of Testing and Material



2) RECOMMENDED OILS

Use only oils listed below or equivalent.

Do not mix different brand oil.

Service point	Kind of fluid	Capacity l (U.S. gal)	Ambient temperature °C (°F)								
			-20 (-4)	-10 (14)	0 (32)	10 (50)	20 (68)	30 (86)	40 (104)		
Engine oil pan	Engine oil	24 (6.3)					SAE 30				
				SAE 10W							
			SAE 10W-30								
				SAE 15W-40							
Swing drive	Gear oil	5.0 (1.3)					SAE 85W-140				
Final drive		5.8×2 (1.5×2)									
Hydraulic tank	Hydraulic oil	Tank; 160 (42)	ISO VG 32								
		System; 275 (73)	ISO VG 46								
			ISO VG 68								
Fuel tank	Diesel fuel	400 (106)	ASTM D975 NO.1								
			ASTM D975 NO.2								
Fitting (Grease nipple)	Grease	As required	NLGI NO.1								
			NLGI NO.2								
Radiator (Reservoir tank)	Mixture of antifreeze and water 50 : 50	35 (9.2)	Ethylene glycol base permanent type								

- SAE : Society of Automotive Engineers
- API : American Petroleum Institute
- ISO : International Organization for Standardization
- NLGI : National Lubricating Grease Institute
- ASTM : American Society of Testing and Material



4. MAINTENANCE CHECK LIST

1) DAILY SERVICE BEFORE STARTING

Check items	Service	Page
Visual check		
Fuel tank	Check, Refill	6-25
Hydraulic oil level	Check, Add	6-30
Engine oil level	Check, Add	6-18
Coolant level	Check, Add	6-20
Control panel & pilot lamp	Check, Clean	6-40
Prefilter	Check, Clean	6-26
Fan belt tension	Check, Adjust	6-24
★ Attachment pin and bushing	Lubricate	6-39
· Boom cylinder tube end		
· Boom foot		
· Boom cylinder rod end		
· Arm cylinder tube end		
· Arm cylinder rod end		
· Boom + Arm connecting		
· Bucket cylinder tube end		

★ Lubricate every 10 hours or daily for initial 100 hours.

2) EVERY 50 HOURS SERVICE

Check items	Service	Page
Fuel tank (water, sediment)	Drain	6-25
Track tension	Check, Adjust	6-35
Swing bearing grease	Lubricate	6-33
Swing reduction gear oil	Check, Add	6-33
Swing reduction gear grease	Check, Add	6-33
Attachment pin and bushing	Lubricate	6-39
· Bucket cylinder rod end		
· Bucket + Arm connecting		
· Bucket control link + Arm		
· Bucket control rod		



3) INITIAL 50 HOURS SERVICE

Check items	Service	Page
Engine oil	Change	6-18, 19
Engine oil filter	Replace	6-18, 19
Prefilter (water, element)	Replace	6-26
Fuel filter	Replace	6-27
Bolts & Nuts	Check, Tight	6-8
<ul style="list-style-type: none"> · Sprocket mounting bolts · Travel motor mounting bolts · Swing motor mounting bolts · Swing bearing mounting bolts · Engine mounting bolts · Counterweight mounting bolts · Turning joint locating bolts · Track shoe mounting bolts and nuts · Hydraulic pump mounting bolts 		

※ Service the above items only for the new machine, and thereafter keep the normal service interval.

4) EVERY 200 HOURS SERVICE

Check items	Service	Page
★ Return filter	Replace	6-31
★ Pilot line filter	Replace	6-32
★ Drain filter cartridge	Replace	6-32

★ Replace 3 filters for continuous hydraulic breaker operation only.

5) INITIAL 250 HOURS SERVICE

Check items	Service	Page
Pilot line filter	Replace	6-32
Hydraulic return filter	Replace	6-31
Drain filter cartridge	Replace	6-32
Swing reduction gear oil	Change	6-33



6) EVERY 250 HOURS SERVICE

Check items	Service	Page
Battery (voltage)	Check, Clean	6-40
Aircon & heater fresh air filter	Check	6-44
Air breather element	Replace	6-32
Bolts & Nuts	Check, Tight	6-8
<ul style="list-style-type: none"> · Sprocket mounting bolts · Travel motor mounting bolts · Swing motor mounting bolts · Swing bearing mounting bolts · Engine mounting bolts · Counterweight mounting bolts · Turning joint locating bolts · Track shoe mounting bolts and nuts · Hydraulic pump mounting bolts 		
Attachment pin and bushing	Lubricate	6-39
<ul style="list-style-type: none"> · Boom cylinder tube end · Boom foot · Boom cylinder rod end · Arm cylinder tube end · Arm cylinder rod end · Boom + Arm connecting · Bucket cylinder tube end 		

7) INITIAL 500 HOURS SERVICE

Check items	Service	Page
Travel reduction gear oil	Change	6-34

※ Service the above item only for the new machine, and thereafter keep the normal service interval.



8) EVERY 500 HOURS SERVICE

Check items	Service	Page
★Engine oil	Change	6-18, 19
★Engine oil filter	Replace	6-18, 19
Radiator, cooler fin and charge air cooler	Check, Clean	6-23
☆Air cleaner element (primary)	Check, Clean	6-25
Fuel filter element	Replace	6-27
Prefilter	Change	6-26

★ If you use high sulfur containing fuel above than 0.5% or use low grade of engine oil reduce change interval.

☆ Clean the primary element only after 500 hours operation or when the air cleaner warning lamp blinks. Replace primary element and safety element after 4 times cleanings of primary element.

9) EVERY 1000 HOURS SERVICE

Check items	Service	Page
Travel motor reduction gear oil	Change	6-34
Swing reduction gear oil	Change	6-33
Grease in swing gear and pinion	Change	6-33
Hydraulic oil return filter	Replace	6-31
Drain filter cartridge	Replace	6-32
Pilot line filter	Replace	6-32

10) EVERY 2000 HOURS SERVICE

Check items	Service	Page
Hydraulic tank		
★ Oil *1	Change	6-30
· Suction strainer	Check, Clean	6-31
Coolant	Change	6-20, 21, 22, 23

*1 Conventional hydraulic oil

★ Change oil every 600 hours of continuous hydraulic breaker operation.

11) EVERY 5000 HOURS SERVICE

Check items	Service	Page
Hydraulic tank		
★ Oil *2	Change	6-30

*2 Hyundai genuine long life hydraulic oil

★ Change oil every 1000 hours of continuous hydraulic breaker operation.



11) WHEN REQUIRED

Whenever you have trouble in the machine, you must perform the service of related items, system by system.

Check items	Service	Page
Fuel system		
· Fuel tank	Drain or Clean	6-25
· Prefilter	Clean or Replace	6-26
· Fuel filter element	Replace	6-27
Engine lubrication system		
· Engine oil	Change	6-18, 19
· Engine oil filter	Replace	6-18, 19
Engine cooling system		
· Coolant	Add or Change	6-20, 21, 22, 23
· Radiator	Clean or Flush	6-20, 21, 22, 23
· Charge air cooler	Check	6-23
Engine air system		
· Air cleaner element	Replace	6-25
Hydraulic system		
· Hydraulic oil	Add or Change	6-30
· Return filter	Replace	6-31
· Drain line filter	Replace	6-32
· Pilot line filter	Replace	6-32
· Element of breather	Replace	6-32
· Suction strainer	Clean	6-31
Under carriage		
· Track tension	Check, Adjust	6-35
Bucket		
· Tooth	Replace	6-37
· Side cutter	Replace	6-37
· Linkage	Adjust	6-36
· Bucket assy	Replace	6-36
Air conditioner and heater		
· Fresh air filter	Clean, Replace	6-43
· Recirculation filter	Clean	6-44

5. MAINTENANCE CHART

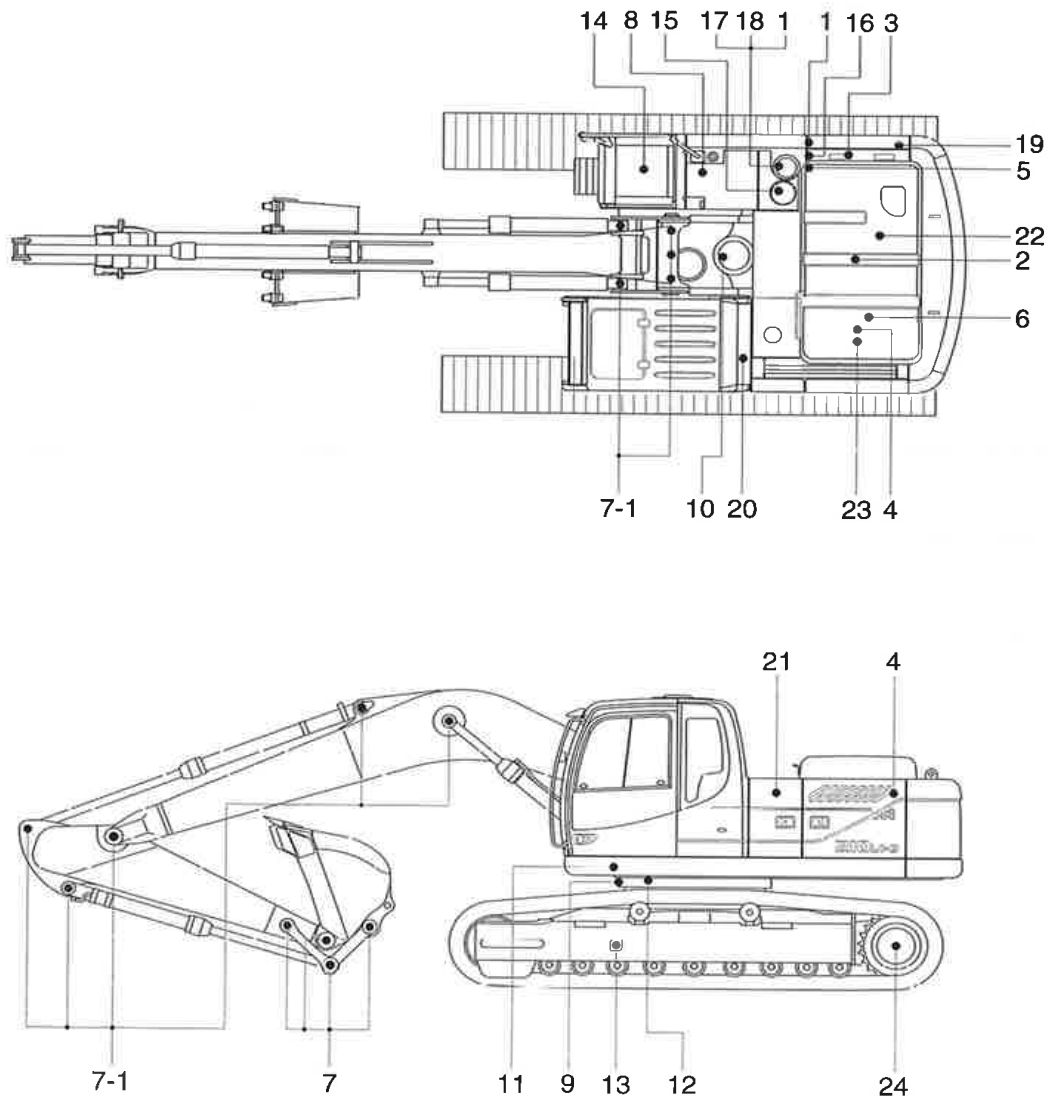

21096MA05

Caution

1. Service intervals are based on the hour meter reading.
2. The number of each item shows the lubrication point on the machine.
3. Stop engine while filling oil, and use no open flames.



Service interval	No.	Description	Service action	Oil symbol	Capacity / (U.S.gal)	Service points No.
10 Hours or daily	1	Hydraulic oil level	Check, Add	HO	160 (42)	1
	2	Engine oil level	Check, Add	EO	24 (6.3)	1
	4	Radiator coolant	Check, Add	C	35 (9.2)	1
	5	Prefilter (water, element)	Check, Clean	-	-	1
	6	Fan belt tension and damage	Check, Adjust	-	-	1
	8	Fuel tank	Check, Refill	DF	400 (106)	1
50 Hours or weekly	7	Attachment pins & bushing	Check, Add	PGL	-	5
	8	Fuel tank (water, sediment)	Check, Clean	-	-	1
	9	Swing bearing grease	Check, Add	PGL	-	3
	10	Swing reduction gear case	Check, Add	GO	5.0 (1.3)	1
	13	Track tension	Check, Adjust	PGL	-	2
250 Hours	7-1	Attachment pins & bushing	Check, Add	PGL	-	12
	14	Battery	Check, Clean	-	-	1
	17	Air breather element	Replace	-	-	1
	20	Aircon and heater fresh air filter	Check, Clean	-	-	1
500 Hours	2	Engine oil	Change	EO	24 (6.3)	1
	3	Engine oil filter	Replace	-	-	1
	5	Prefilter	Replace	-	-	1
	21	Air cleaner element (primary)	Check, Clean	-	-	1
	22	Fuel filter element	Replace	-	-	1
	23	Radiator, oil cooler, charge air cooler	Check, Clean	-	-	3
1000 Hours	10	Swing reduction gear case	Change	GO	5.0 (1.3)	1
	12	Swing gear and pinion grease	Change	PGL	11.7 kg (25.8 lb)	1
	15	Hydraulic oil return filter	Replace	-	-	1
	16	Drain filter cartridge	Replace	-	-	1
	19	Pilot line filter element	Replace	-	-	1
	24	Travel reduction gear case	Change	GO	5.8 (1.5)	2
2000 Hours	1	Hydraulic oil *1	Change	HO	160 (42)	1
	4	Radiator coolant	Change	C	35 (9.2)	1
	18	Hydraulic oil suction strainer	Check, Clean	-	-	1
5000 Hours	1	Hydraulic oil *2	Change	HO	160 (42)	1
As required	20	Aircon & heater fresh filter	Replace	-	-	1
	20	Aircon & heater recirculation filter	Clean, Replace	-	-	1
	21	Air cleaner element (primary, safety)	Replace	-	-	2

*1 Conventional hydraulic oil

*2 Hyundai genuine long life hydraulic oil

※ Oil symbol

Please refer to the recommended lubricants for specification.

DF : Diesel fuel

GO : Gear oil

HO : Hydraulic oil

C : Coolant

PGL : Grease

EO : Engine oil

6. SERVICE INSTRUCTION

1) CHECK ENGINE OIL LEVEL

Check the oil level with the machine on a flat ground before starting engine.

- (1) Pull out the dipstick and wipe with a clean cloth.
 - (2) Check the oil level by inserting the dipstick completely into the hole and pulling out again.
 - (3) If oil level is LOW, add oil and then check again.
 - ※ If the oil is contaminated or diluted, change the oil regardless of the regular change interval.
 - ※ Check oil level after engine has been stopped for 15 minutes.
- ▲ Do not operate unless the oil level is in the normal range.

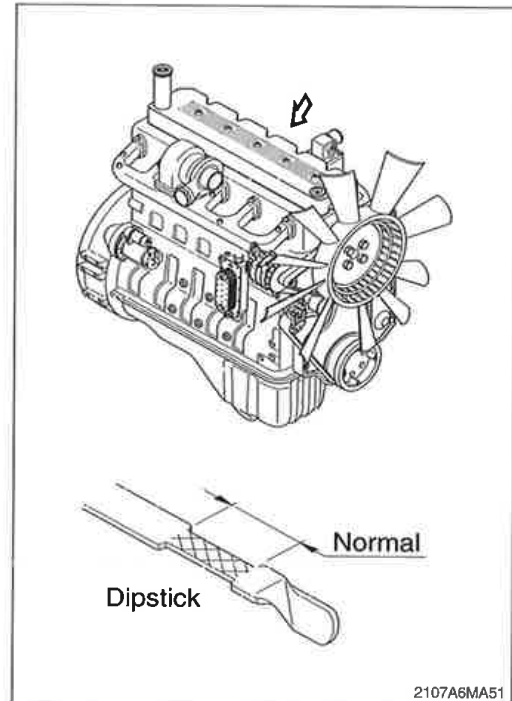

2) REPLACEMENT OF ENGINE OIL AND OIL FILTER

- (1) Warm up the engine.
- (2) Remove the plug and allow the oil to drain.
 - ※ A drain pan with a capacity of 24 liters (6.3 U.S. gallons) will be adequate.

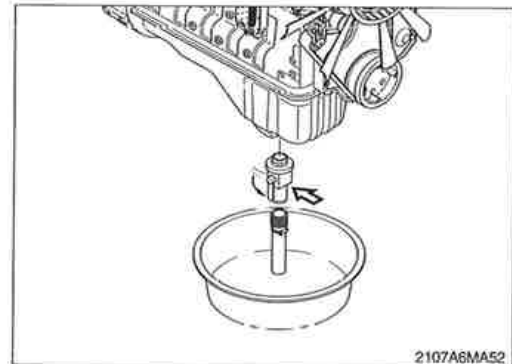

- (3) Clean around the filter head, remove the filter and clean the gasket surface.
 - Wrench size : 90 ~ 95 mm (3.5~3.8 in)

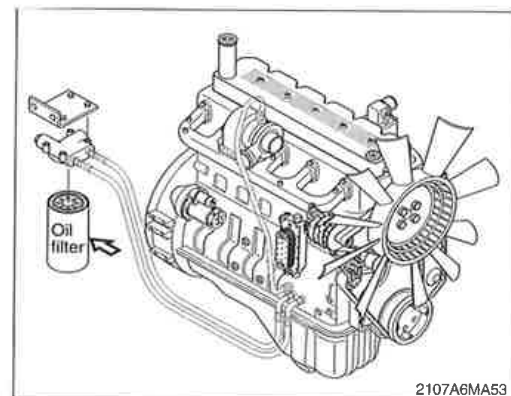



- (4) Apply a light film of lubricating oil to the gasket sealing surface before installing the filters.
 ※ Fill the filters with clean lubricating oil.

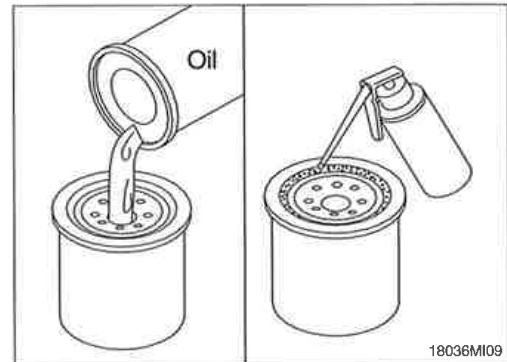

- (5) Install the filter to the filter head.
 ※ **Mechanical over-tightening may distort the threads or damage the filter element seal.**
 · Install the filter as specified by the filter manufacturer.

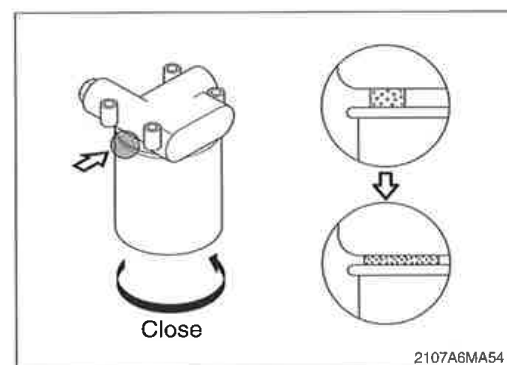

- (6) Fill the engine with clean oil to the proper level.
 · Quantity : 24 l (6.3 U.S. gallons)

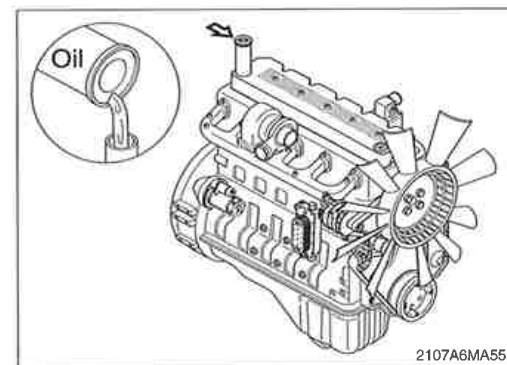

- (7) Operate the engine at low idle and inspect for leaks at the filters and the drain plug.
 Shut the engine off and check the oil level with the dipstick. Allow 15minutes for oil to drain down before checking.

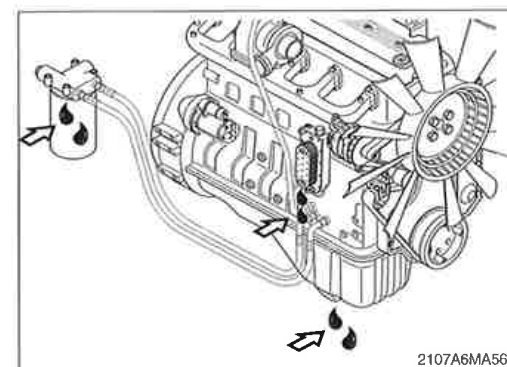

3) CHECK COOLANT

- (1) Check if the level of coolant in reservoir tank is between FULL and LOW.
 - (2) Add the mixture of antifreeze and water after removing the cap of the reservoir tank if coolant is not sufficient.
 - (3) Be sure to add the coolant by opening the cap of radiator when coolant level is below LOW.
 - (4) Replace gasket of radiator cap when it is damaged.
- ▲ Hot coolant can spray out if radiator cap is removed while engine is hot. Remove the cap after the engine has cooled down.**

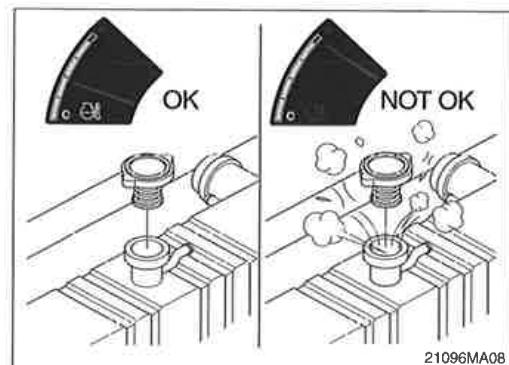
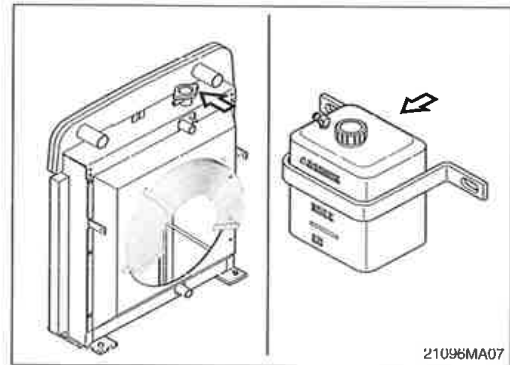

4) FLUSHING AND REFILLING OF RADIATOR

- (1) Change coolant
 - ▲ Avoid prolonged and repeated skin contact with used antifreeze. Such prolonged repeated contact can cause skin disorders or other bodily injury. Avoid excessive contact-wash thoroughly after contact. Keep out of reach of children.**
 - ※ Protect the environment : Handling and disposal of used antifreeze can be subject to federal, state, and local law regulation. Use authorized waste disposal facilities, including civic amenity sites and garages providing authorized facilities for the receipt of used antifreeze. If in doubt, contact your local authorities for guidance as to proper handling of used antifreeze.**

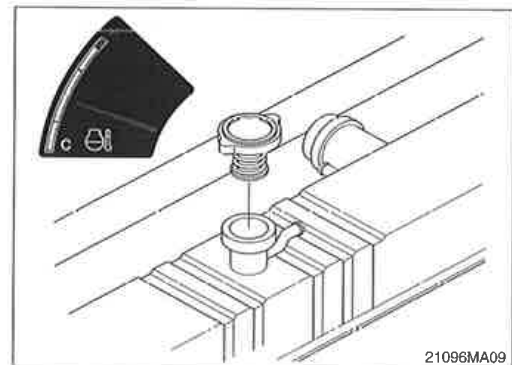



- ③ Fill the cooling system with clean water.
- ※ Be sure to vent the engine and aftercooler for complete filling.
- ※ Do not install the radiator cap or the new coolant filter.

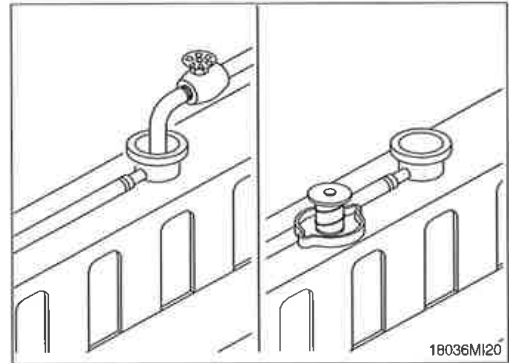

- ④ Operate the engine for 5 minutes with the coolant temperature above 80 °C (176 °F). Shut the engine off, and drain the cooling system.
- ※ If the water being drained is still dirty, the system must be flushed again until the water is clean.

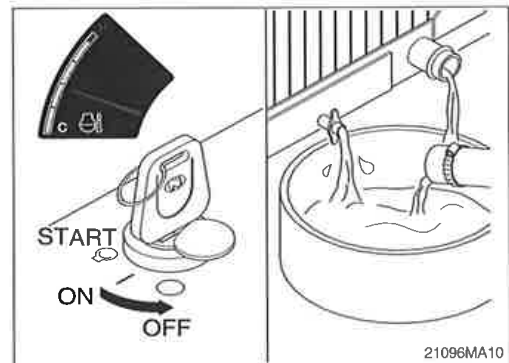

(3) Cooling system filling

- ① Use a mixture of 50 percent water and 50 percent ethylene glycol antifreeze to fill the cooling system.
Coolant capacity (engine only) : 10 l (2.6 U.S. gallons)
- ※ Use the correct amount of DCA4 corrosion inhibitor to protect the cooling system.

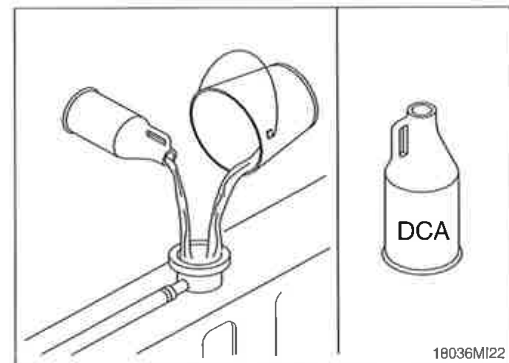

- ② The system has a maximum fill rate of 19 liters (5.0 U.S. gallons) per minute. Do not exceed this fill rate.
- ※ The system must be filled slowly to prevent air locks. During filling, air must be vented from the engine coolant passage.

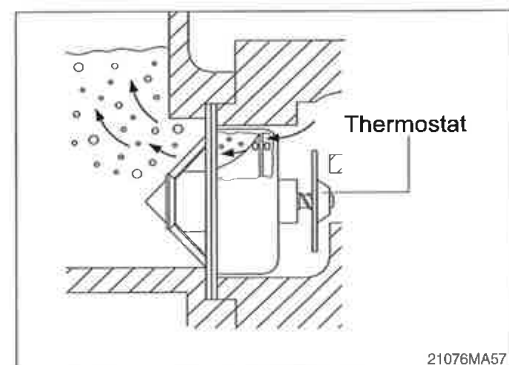

- ③ Install the pressure cap. Operate the engine until it reaches a temperature 80 °C (176 °F), and check for coolant leaks. Check the coolant level again to make sure the system is full of coolant.

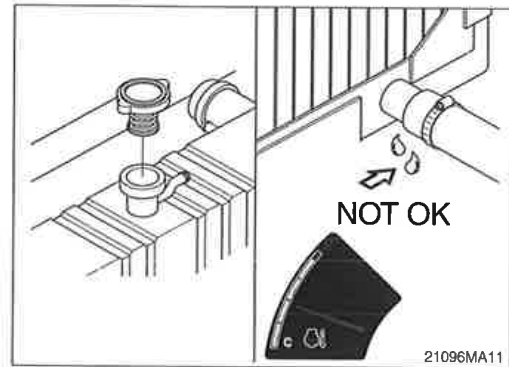

5) CLEAN RADIATOR AND OIL COOLER

Check, and if necessary, clean and dry outside of radiator and oil cooler. After working in a dusty place, clean radiator more frequently.

- (1) Visually inspect the radiator for clogged radiator fins.
- (2) Use 550 kPa (80 psi) air pressure to blow the dirt and debris from the fins. Blow the air in the opposite direction of the fan air flow.
- (3) Visually inspect the radiator for bent or broken fins.
 - ※ If the radiator must be replaced due to bent or broken fins which can cause the engine to overheat, refer to the manufacturer's replacement procedures.
- (4) Visually inspect the radiator for core leaks.

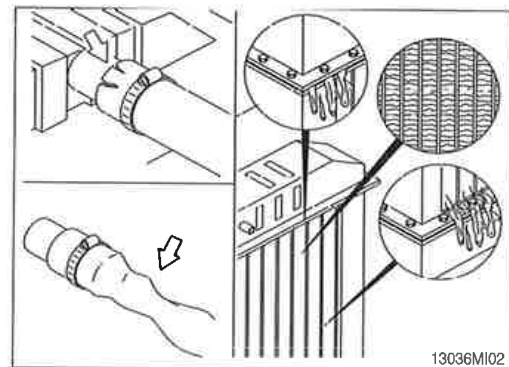
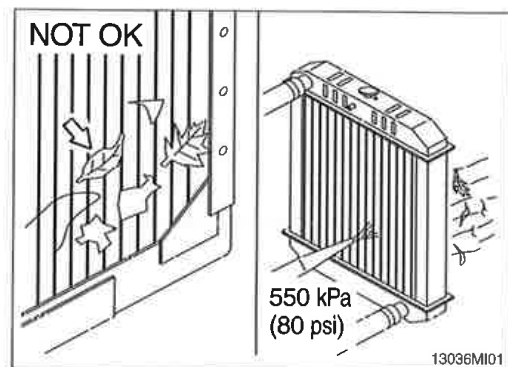

6) CHECK CHARGE AIR COOLER

Inspect the charge air cooler for dirt and debris blocking the fins. Check for cracks, holes, or other damage. If damage is found, please contact Hyundai distributor.

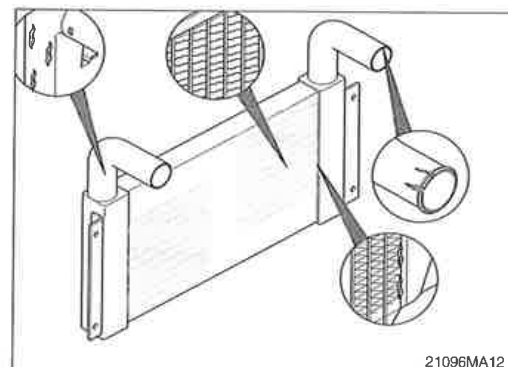

7) FAN BELT TENSION

(1) Measure the belt deflection at the longest span of the belt.

- Maximum deflection : 9.5 - 12.7 mm
(3/8 to 1/2 inch)

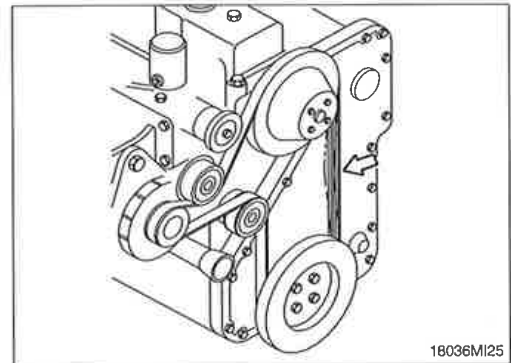

18036MI25

(2) Inspect the drive for damage.

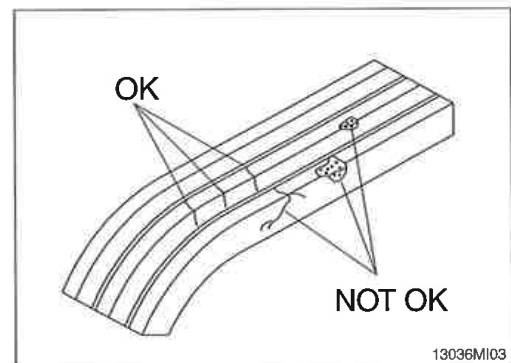

13036MI03

(3) Inspect the drive belt, tension bearing and fan hub.

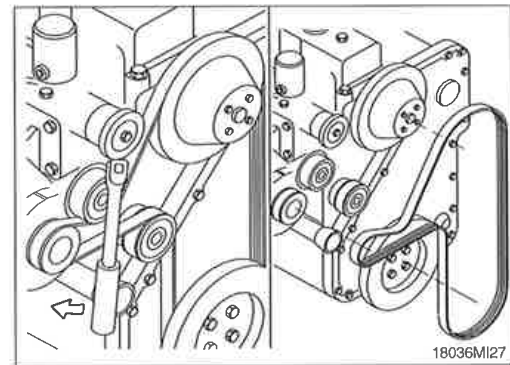

18036MI27

8) INSPECTION OF COOLING FAN

▲ Personal injury can result from a fan blade failure. Never pull or pry on the fan. This can damage the fan blade and cause fan failure.

※ Rotate the crankshaft by using the engine barring gear.

※ A visual inspection of the cooling fan is required daily.

Check for cracks, loose rivets, and bent or loose blades.

Check the fan to make sure it is securely mounted. Tighten the capscrews if necessary. Replace any fan that is damaged.

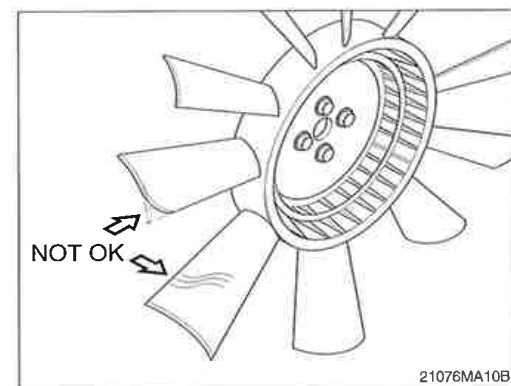

21076MA10B



- ▲ Wait until the temperature is below 50 °C (122 °F) before removing the coolant system pressure cap.

Failure to do so can cause personal injury from heated coolant spray.

Drain the cooling system by opening the drain valve on the radiator and removing the plug in the bottom of the water inlet. A drain pan with a capacity of 40 liters (10 U.S. gallons) will be adequate in most applications.

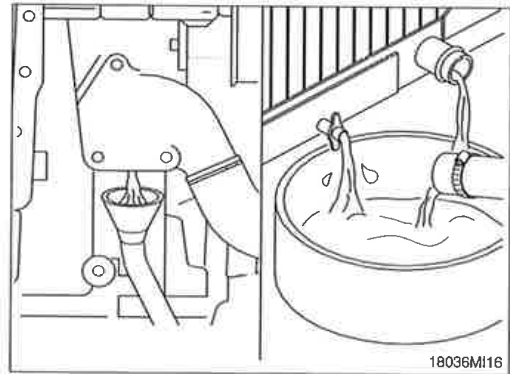

(2) Flushing of cooling system

- ① Fill the system with a mixture of sodium carbonate and water (or a commercially available equivalent).

- ※ Use 0.5kg (1.0 pound) of sodium carbonate for every 23 liters (6.0 U.S. gallons) of water.

- ※ Do not install the radiator cap. The engine is to be operated without the cap for this process.

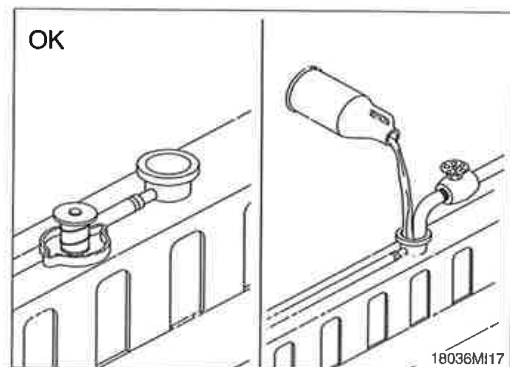

- ※ During filling, air must be vented from the engine coolant passages. Open the engine venting petcock.

The system must be filled slowly to prevent air locks. Wait 2 to 3 minutes to allow air to be vented, then add mixture to bring the level to the top.

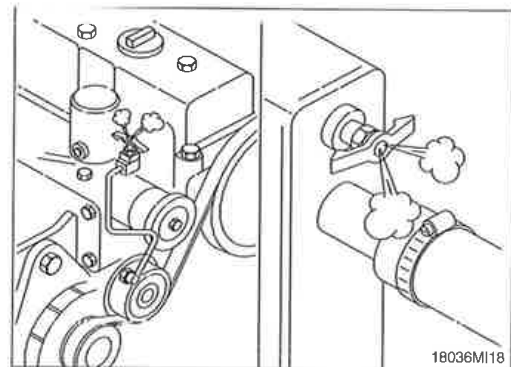

- ② Operate the engine for 5 minutes with the coolant temperature above 80 °C (176 °F).

Shut the engine off, and drain the cooling system.

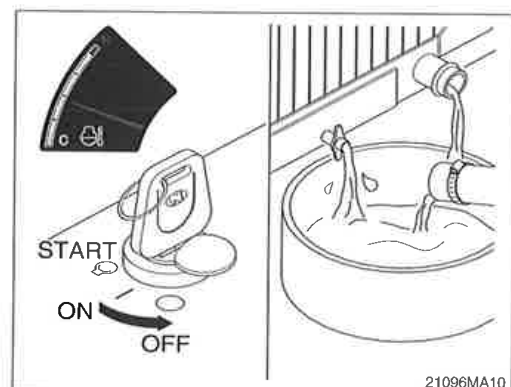

9) CLEANING OF AIR CLEANER

(1) Primary element

- ① Loosen the clamps and remove the element.
 - ② Clean the inside of the body.
 - ③ Clean the element with pressurized air.
 - Remove the dust inside of the element by the pressurized air (below 3 kgf/cm², 40 psi) forward and backward equally.
 - ④ Inspect for cracks or damage of element by putting a light bulb inside of the element.
 - ⑤ Insert element and tighten wing nut.
- ※ Replace the primary element after 4 times cleanings.

(2) Safety element

- ※ Replace the safety element only when the primary element is cleaned for the 4 times.
- ※ Always replace the safety element. Never attempt to reuse the safety element by cleaning the element.

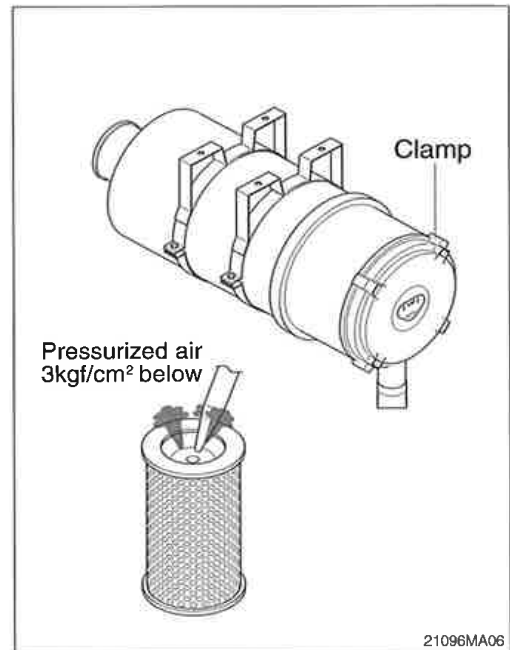

10) FUEL TANK

- (1) Fill fuel fully when system the operation to minimize water condensation, and check it with fuel gauge before starting the machine.
 - (2) Drain the water and sediment in the fuel tank by opening the drain cock.
 - ※ Be sure to LOCK the cap of fuel tank.
 - ※ Remove the strainer of the fuel tank and clean it if contaminated.
- ▲ Stop the engine when refueling.
All lights and flames shall be kept at a safe distance while refueling.

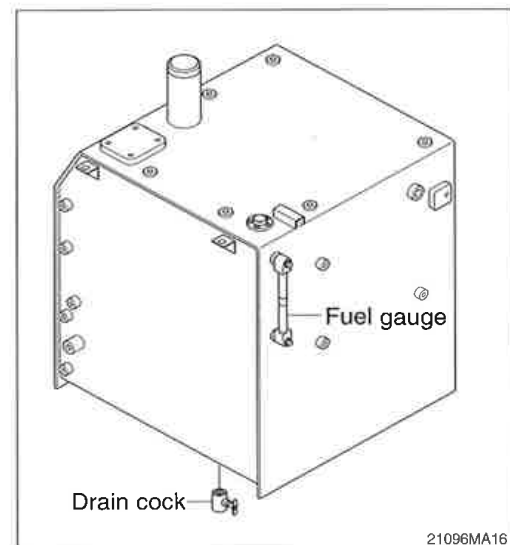



11) PREFILTER

- ※ Inspect or drain the collection bowl of water daily and replace the element every 500hours.

(1) Drain water

- ① Open bowl drain valve to evacuate water.
- ② Close drain valve.

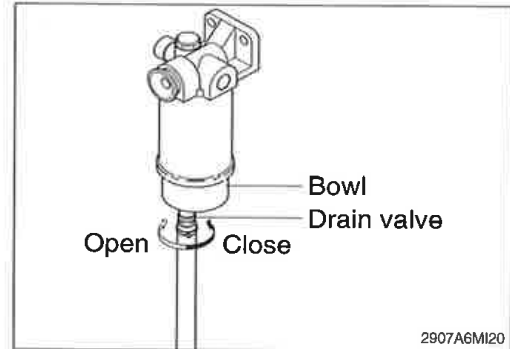

(2) Replace element

- ① Drain the unit of fuel. Follow "Drain water" Instructions above.
- ② Remove element, fuel warmer and bowl from filter head.
- ※ The bowl is reusable, do not damage or discard.
- ③ Separate element from bowl. Clean bowl and seal gland.

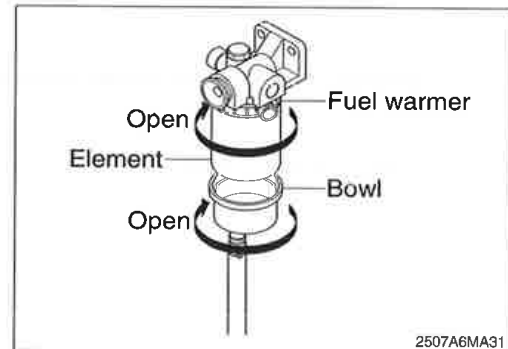

- ④ Lubricate new bowl seal with clean fuel or motor oil and place in bowl gland.
- ⑤ Attach bowl to new element firmly by hand.
- ⑥ Lubricate new element seal and place in element top gland.
- ⑦ Attach the element, fuel warmer and bowl to the head.

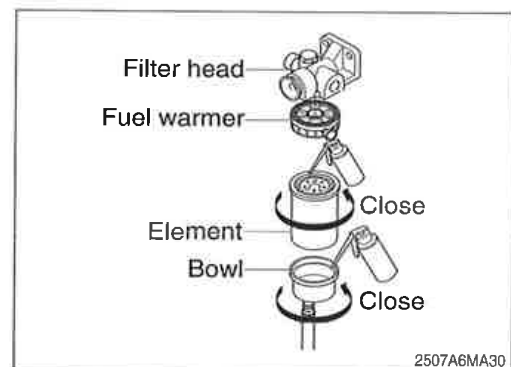

12) REPLACEMENT OF FUEL FILTER

- (1) Clean around the filter head, remove the filter and clean the gasket surface.
 - Wrench size : 90~95 mm (3.5~3.8 in)
- (2) Replace the O-ring.
- (3) Apply engine oil on the gasket of new filter when mounting, and tighten 3/4 to 1 turn more after the gasket touches the filter head.
- (4) Relieve the air after mounting.
 - ※ Do not pre-fill an on-engine fuel filter with fuel. The system must be primed after the fuel filter is installed. Pre filling the fuel can result in debris entering the fuel system and damaging fuel system components.
 - ※ Check for fuel leakage after the engine starts. If air is in the fuel system, the engine will not start. Start engine after bleeding the air according to the method of bleeding air.

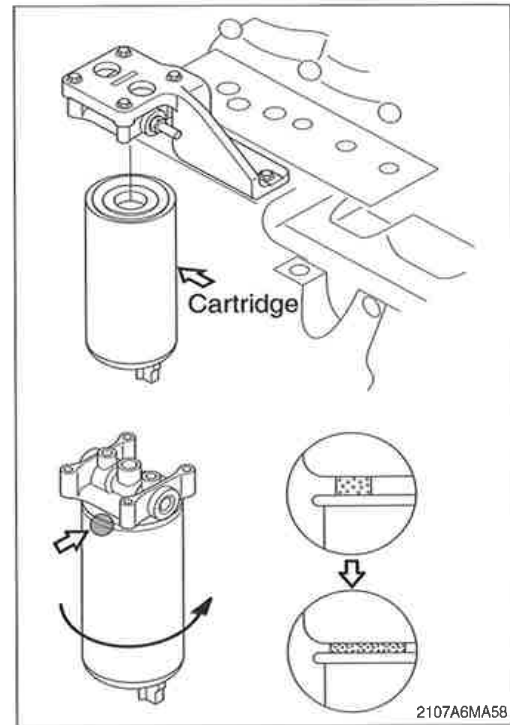

13) BLEEDING THE FUEL SYSTEM

- (1) Loosen fuel supply line plug at the outlet of prefilter.
 - (2) Do hand-priming the lift pump repeatedly until air bubbles comes out from fuel supply line completely.
 - (3) Tighten fuel supply line to its origin position.
- ⚠ The fuel pump, high-pressure fuel lines and fuel rail contain very high-pressure fuel. Never loosen any fittings while the engine is running. Personal injury and property damage can result. Wait at least 10 minutes after shutting down the engine before loosening any fittings in the high-pressure fuel system to allow pressure to decrease to a lower level.

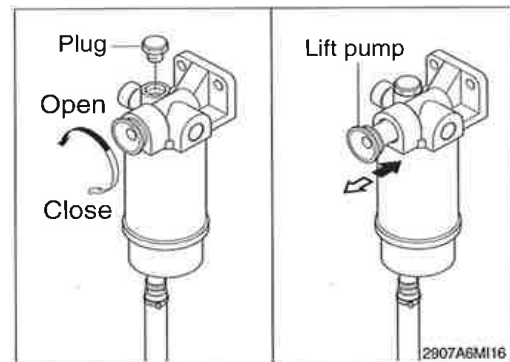

14) BELT TENSIONER, AUTOMATIC ADJUSTMENT

- (1) Every 1000hours, or 1 year, whichever occurs first, inspect the automatic belt tensioner.

With the engine turned off, check that neither the top nor bottom tensioner arm stop is touching the cast boss on the tensioner body. If either of the stops is touching a boss, the alternator belt must be replaced. Check to make sure the correct belt part number is being used if either condition exists.

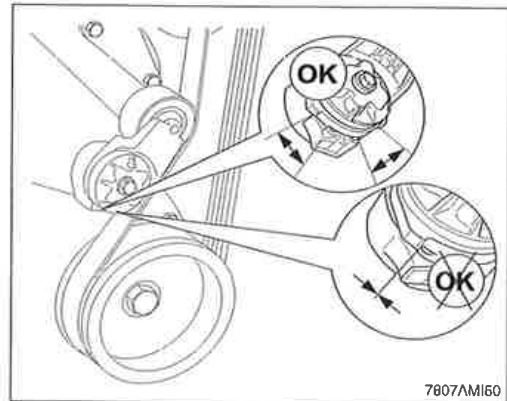

- (2) Check the tensioner pulley and body for cracks.

If any cracks are noticed, the tensioner must be replaced. Refer to a Cummins Authorized Repair facility. Check the tensioner for dirt buildup. If this condition exists, the tensioner must be removed and steam-cleaned.

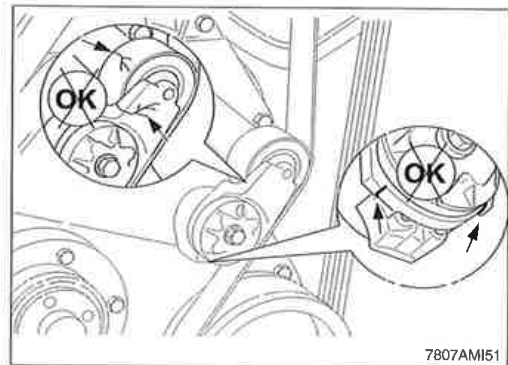

- (3) Check that the bottom tensioner arm stop is in contact with the bottom tensioner arm stop boss on the tensioner body. If these two are not touching, the tensioner must be replaced.

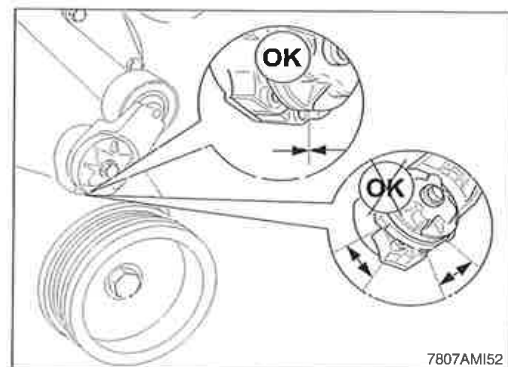

- (4) Inspect the tensioner for evidence of the pivoting tensioner arm contacting the stationary circular base. If there is evidence of these two areas touching, the pivot tube bushing has failed and the tensioner must be replaced.

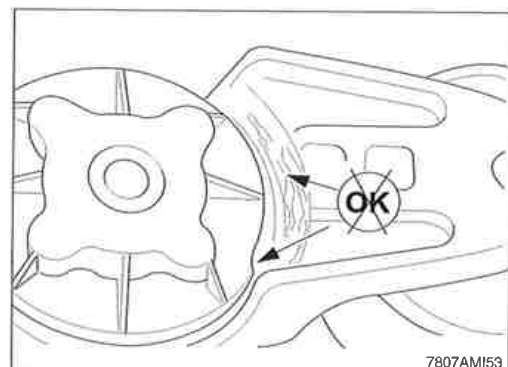



- (5) A worn tensioner that has play in it or a belt that “walks” off its pulley possibly indicates pulley misalignment.
- ※ Maximum pulley misalignment is three degrees. This measurement can be taken with a straightedge and an inclinometer.
- (6) Install the belt.

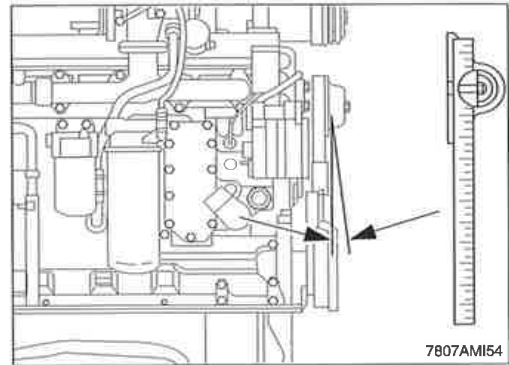

15) LEAKAGE OF FUEL

- ⚠ Be careful and clean the fuel hose, injection pump, fuel filter and other connections as the leakage from these part can cause fire.

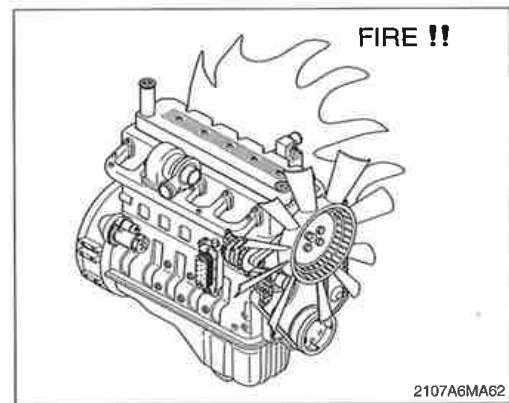

16) HYDRAULIC OIL CHECK

- (1) Stop the engine after retract the arm and bucket cylinders, then lower the boom and set the bucket on the ground at a flat location as in the illustration.
- (2) Check the oil level at the level gauge of hydraulic oil tank.
- (3) The oil level is normal if between the red lines.

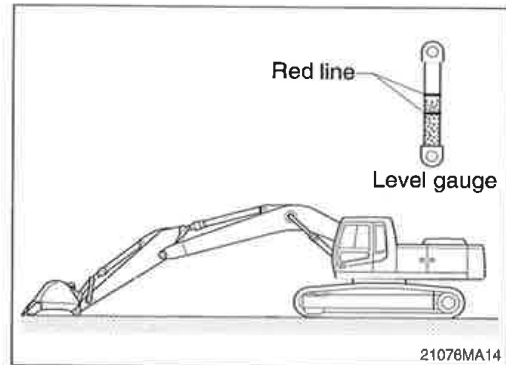

17) FILLING HYDRAULIC OIL

- (1) Stop the engine to the position of level check.
- (2) Loosen the cap and relieve the pressure in the tank by pushing the top of the air breather.
- (3) Remove the breather on the top of oil tank and fill the oil to the specified level.
 - Tightening torque : $1.44 \pm 0.3 \text{ kgf} \cdot \text{m}$
($10.4 \pm 2.1 \text{ lbf} \cdot \text{ft}$)
- (4) Start engine after filling and operate the work equipment several times.
- (5) Check the oil level at the level check position after engine stops.

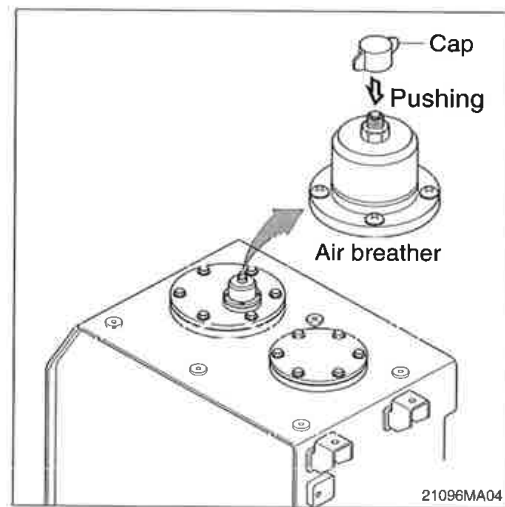

18) CHANGE HYDRAULIC OIL

- (1) Lower the bucket on the ground pulling the arm and bucket cylinder to the maximum.
- (2) Loosen the cap and relieve the pressure in the tank by pushing the top of the air breather.
- (3) Remove the cover.
 - Tightening torque : $6.9 \pm 1.4 \text{ kgf} \cdot \text{m}$
($50 \pm 10 \text{ lbf} \cdot \text{ft}$)
- (4) Prepare a suitable container.
- (5) To drain the oil loosen the drain plug at the bottom of the oil tank.
- (6) Fill proper amount of recommended oil.
- (7) Put the breather in the right position.
- (8) Bleed air hydraulic pump loosen the air breather at top of hydraulic pump assembly.
- (9) Start engine and run continually. Release the air by full stroke of each control lever.

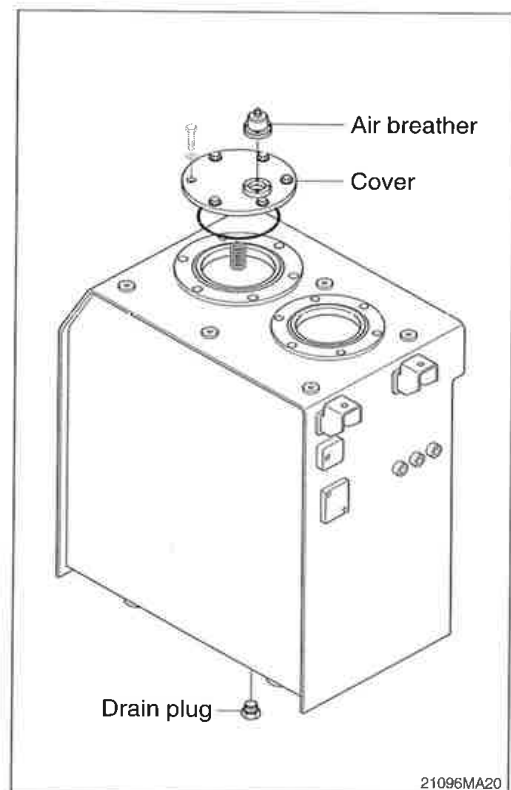



19) CLEAN SUCTION STRAINER

Clean suction strainer as follows paying attention to the cause to be kept during oil filling.

- (1) Remove the cover on the top of the oil tank.
 - Tightening torque : $6.9 \pm 1.4 \text{ kgf} \cdot \text{m}$
($50 \pm 10 \text{ lbf} \cdot \text{ft}$)
 - (2) Pull out the strainer in the tank.
 - (3) Wash the foreign material on the suction strainer with gasoline or cleaning oil.
 - (4) Replace the suction strainer if it is damaged.
 - (5) Assemble with reverse order of disassembly. Be sure to install a new O-ring and reinsert in the oil tank.
- ※ Loosen the bolt slowly at the cover can be spring out by the spring when removing it.

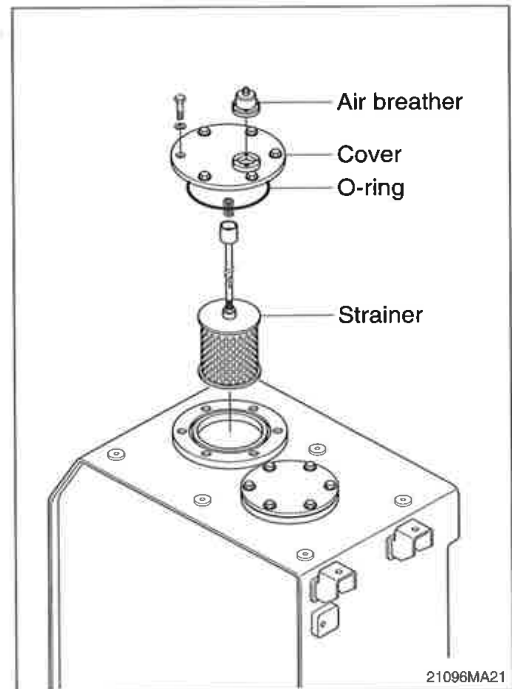

20) REPLACEMENT OF RETURN FILTER

Replace as follows paying attention to the cause to be kept during the replacement.

- (1) Remove the cover.
 - Tightening torque : $6.9 \pm 1.4 \text{ kgf} \cdot \text{m}$
($50 \pm 10 \text{ lbf} \cdot \text{ft}$)
- (2) Remove the spring, by-pass valve, and return filter in the tank.
- (3) Replace the element with new one.

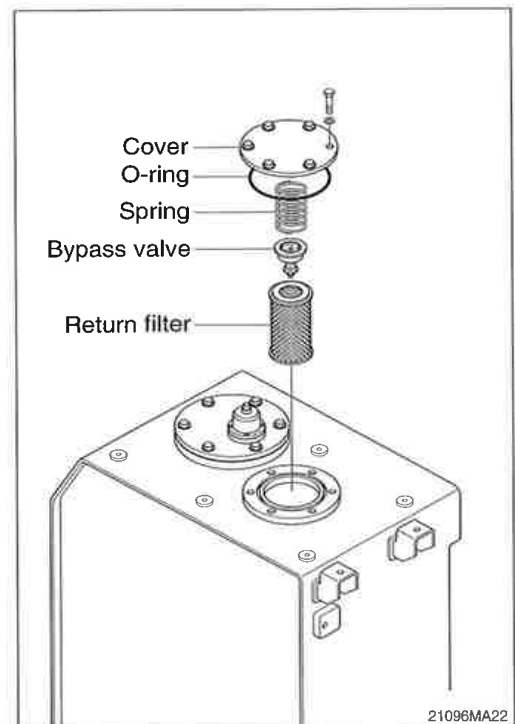

21) REPLACEMENT OF ELEMENT IN HYDRAULIC TANK BREATHER

- (1) Loosen the cap and relieve the pressure in the tank by pushing the top of the air breather.
- (2) Loosen the lock nut and remove the cover.
- (3) Pull out the filter element.
- (4) Replace the filter element new one.
- (5) Apply oil on the O-ring and reassemble by reverse order of disassembly.
 - Tightening torque : 0.2~0.3 kgf · m
(1.4~2.1 lbf · ft)

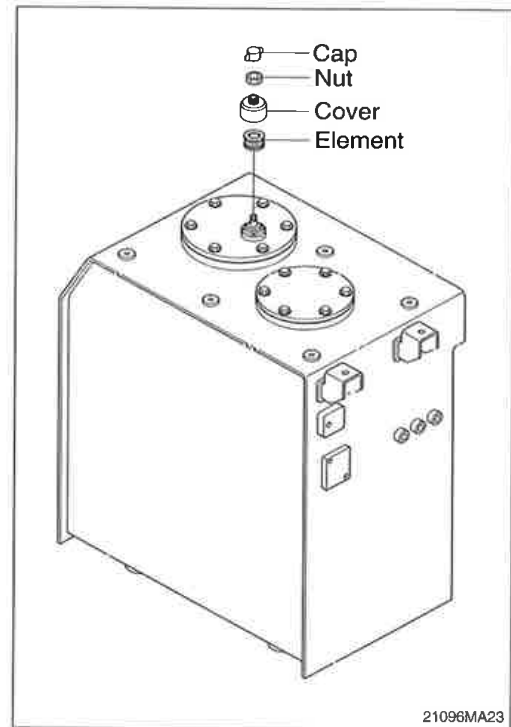

22) REPLACE OF DRAIN FILTER CARTRIDGE

Clean the dust around filter and replace with new one after removing the cartridge.

- ※ Tighten about 2/3 turn more after the gasket of cartridge contacts seal side of filter body for mounting.
- ※ Change cartridge after initial 250 hours of operation. Thereafter, change cartridge every 1000 hours.

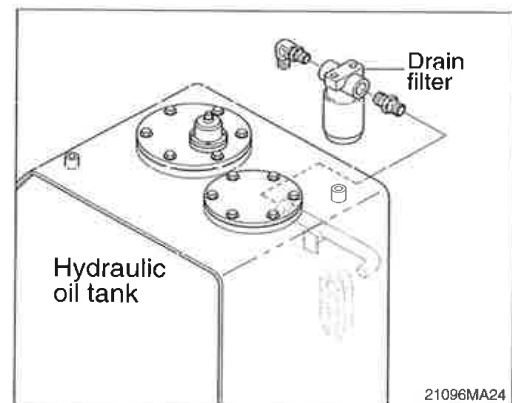

23) REPLACE OF PILOT LINE FILTER

- (1) Loosen the nut positioned on the filter body.
 - (2) Pull out the filter element and clean filter housing.
 - (3) Install the new element and tighten using specified torque.
- ※ Change cartridge after initial 250 hours of operation. Thereafter, change cartridge every 1000 hours.

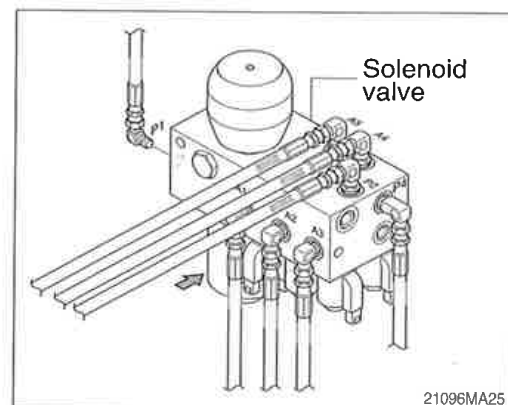



24) CHECK THE SWING REDUCTION GEAR OIL

- (1) Pull out the dipstick and clean it.
- (2) Insert it again.
- (3) Pull out one more time to check the oil level and fill the oil if the level is not sufficient.

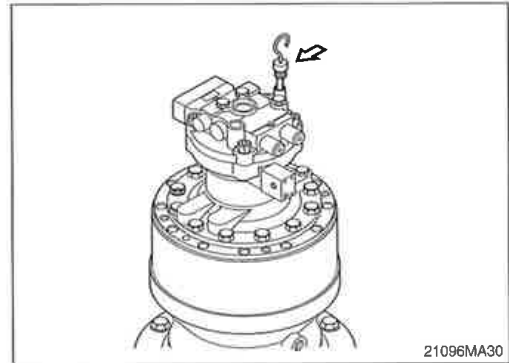

25) CHANGE SWING REDUCTION GEAR OIL

- (1) Raise the temperature of oil by swinging the machine before replace the oil and park the machine on the flat ground.
- (2) Prepare into a proper container.
- (3) Open the cap and loosen the drain valve.
- (4) Clean around the valve and close the drain valve and cap.
Fill proper amount of recommended oil.
· Amount of oil : 5.0 l (1.3 U.S.gal)

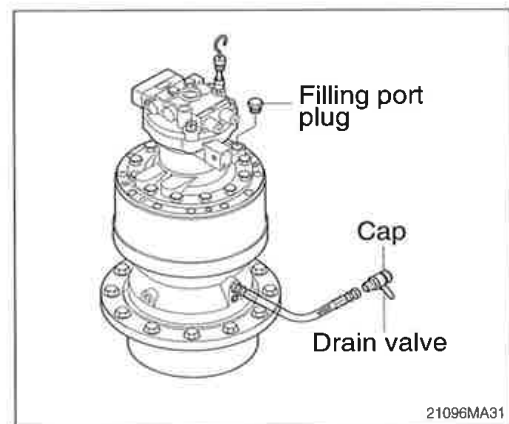

26) LUBRICATE BEARING OF OUTPUT SHAFT IN REDUCTION GEAR

- (1) Remove air vent plug.
- (2) Lubricate NLGI No.2 with grease gun until comes out new grease from air vent port.
· Amount of oil : 1.1 kg (2.4 lb)

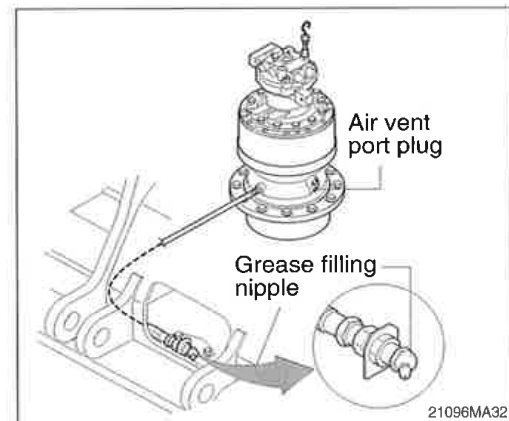

27) LUBRICATE SWING BEARING

- (1) Grease at 3 fitting.
※ Lubricate every 50 hours.

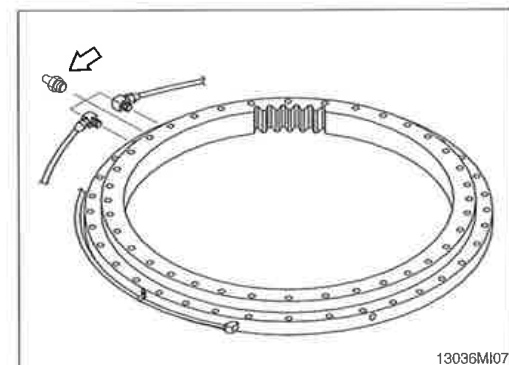

28) SWING GEAR AND PINION

(1) Drain old grease

- ① Remove under cover of lower frame.
- ② Remove drain cover of lower frame.
- ③ Remove filler cover of upper frame.
- ④ Operate full turn (360°) of swing several times.

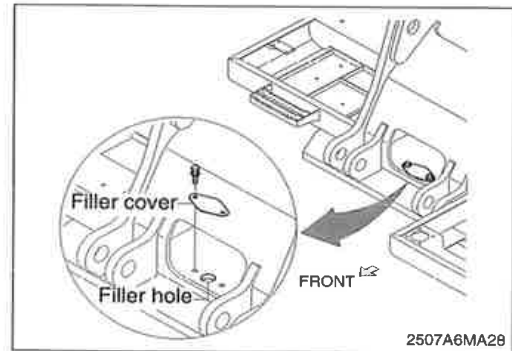

(2) Refill new grease

- ① Install drain cover.
 - ② Fill with new grease.
 - ③ Install filler cover.
- Capacity : 11.7 kg (25.8 lb)

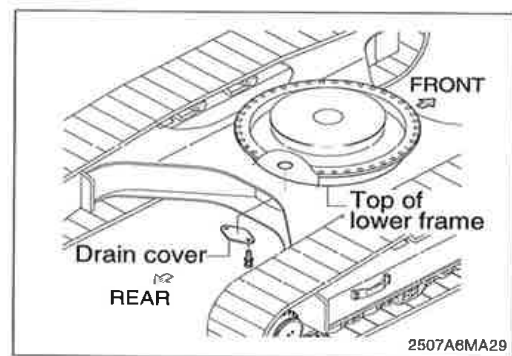

29) CHECK THE TRAVEL REDUCTION GEAR OIL

- (1) Operate the machine to the position of drain plug down to the flat ground.
 - (2) Loosen the level plug and check the oil level.
If the level is at the hole of the plug, it is normal.
Fill the oil if it is not sufficient.
- Amount of oil : 5.8 l (1.5 U.S.gal)

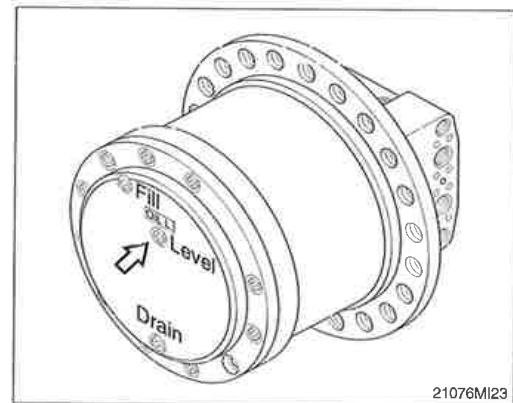

30) CHANGE OF THE TRAVEL REDUCTION GEAR OIL

- (1) Raise the temperature of the oil by traveling machine first.
- (2) Stop when the position of the drain plug is down.
- (3) Loosen the level plug and then the drain plug.
- (4) Drain the oil to adequate container.
- (5) Tighten the drain plug and fill specified amount of oil at filling port.
- (6) Tighten the level plug and travel slowly to check if there is any leakage of oil.

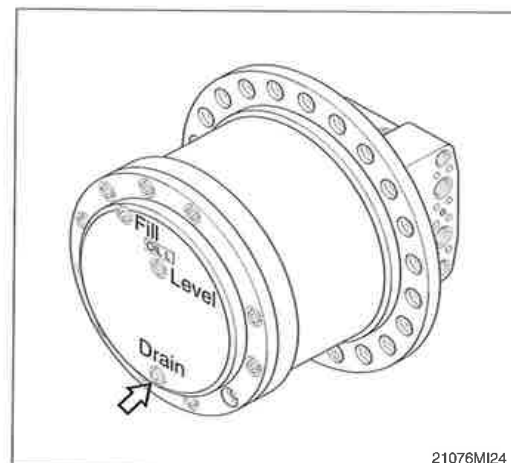

31) LUBRICATE RCV LEVER

Remove the bellows and with a grease gun grease the joint part (A) and sliding parts (B).

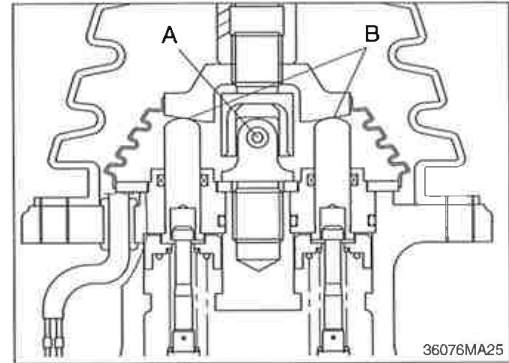

32) ADJUSTMENT OF TRACK TENSION

- ※ It is important to adjust the tension of track properly to extend the lifetime of track and traveling device.
- ※ The wear of pins and bushings on the undercarriage will vary with the working conditions and soil properties.

It is thus necessary to continually inspect the track tension so as to maintain the standard tension on it.

- (1) Raise the chassis with the boom and arm.
- (2) Measure the distance between bottom of track frame on track center and track of shoe.
- ※ Remove mud with rotating the track before measuring.

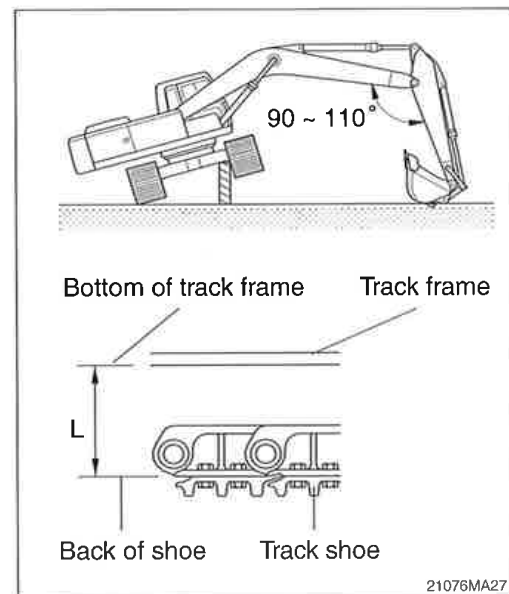

- (3) If the tension is tight, drain the grease in the grease nipple and if the tension is loose, charge the grease.

- ⚠ Personal injury or death can result from grease under pressure.
 - ⚠ When loosening the grease nipple, do not loosen more than one turn as there is a danger of a spring coming out of the nipple because of the high pressure inside.
 - ※ When the grease is drained, move the track to the forward and backward slightly.
- If the track tension is loose even after the grease is charged to the maximum, change the pins and bushings as there are worn seriously.

Length (L)	
300~330 mm	11.8~13"

33) REPLACEMENT OF BUCKET

▲ When knocking the pin in with a hammer, metal particles may fly and cause serious injury, particularly if they get into your eyes. When carrying out this operation, always wear goggles, helmet, gloves, and other protective equipment.

※ When the bucket is removed, place it in a stable condition.

※ When performing joint work, make sure signals to each other and work carefully for safety's sake.

(1) Lower the bucket on the ground as the picture shown in the right.

(2) Lock the safety lever to the LOCK position and stop the engine.

(3) Remove the stopper bolts (1) and nuts (2), then remove pins (3, 4) and remove the bucket.

※ When removing the pins, place the bucket so that it is in light contact with the ground.

※ If the bucket is lowered strongly to the ground, the resistance will be increased and it will be difficult to remove the pins.

※ After remove the pins, make sure that they do not become contaminated with sand or mud and that the seals of bushing on both sides do not become damaged.

(4) Align the arm with holes (A) and the link with holes (B), then coat with grease and install pins(3, 4)

※ When installing the bucket, the O-rings are easily damaged, so fit the O-rings on the boss of the bucket as shown in the picture.

After knocking the pin, move the O-ring down to the regular groove.

(5) Install the stopper bolt (1) and nuts (2) for each pin, then grease the pin.

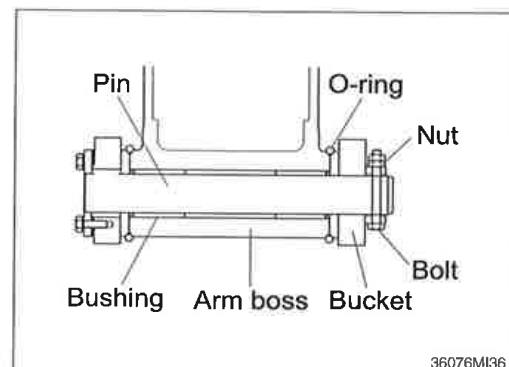
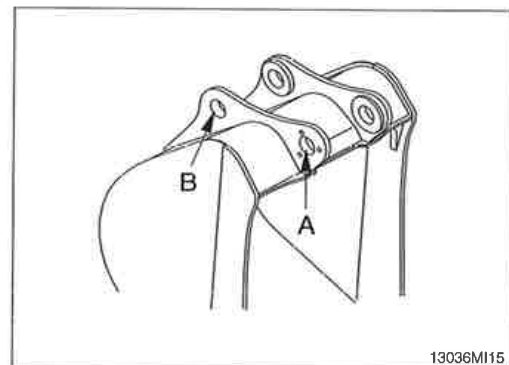
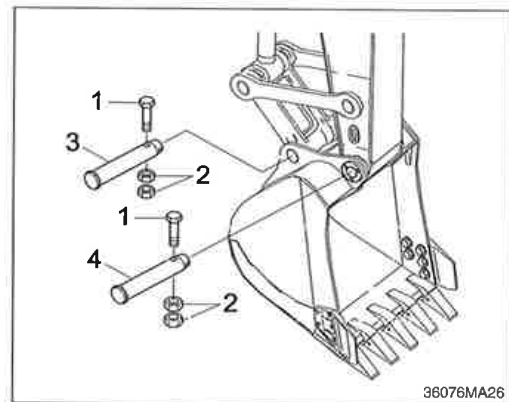
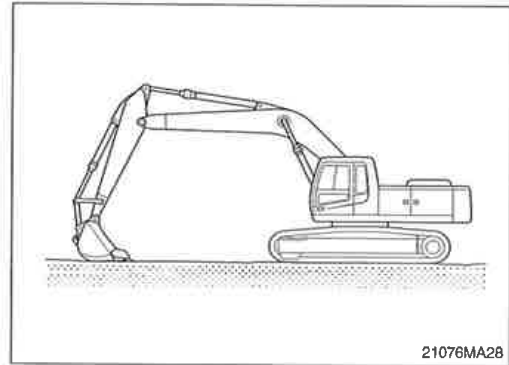



34) REPLACEMENT OF BUCKET TOOTH

(1) Timing of replacement

- ① Check wearing condition as shown in the illustration and replace tooth tip before adapter starts to wear.
- ② If excessive use, tooth adapter has worn out, replacement may become impossible.

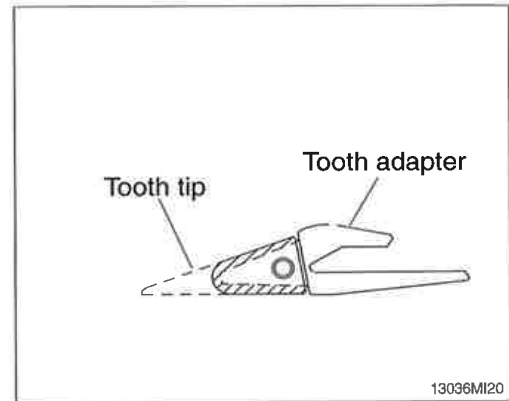

(2) Instructions for replacement

- ① Pull out pin by striking pin with punch or hammer, avoiding damage to locking washer.
 - ② Remove dust and mud from surface of tooth adapter by using knife.
 - ③ Place locking washer in its proper place, and fit tooth tip to adapter.
 - ④ Insert pin until locking washer is positioned at tooth pin groove.
- ▲ Personal injury can result from bucket falling.
- ▲ Block the bucket before changing tooth tips or side cutters.

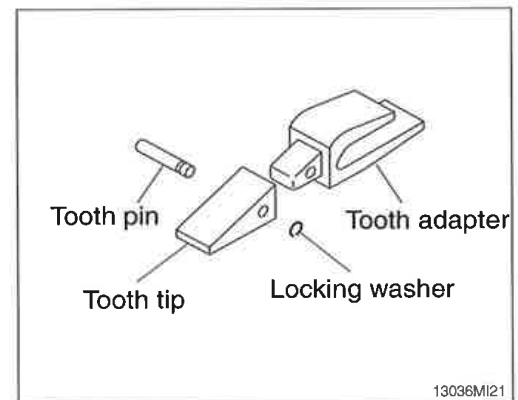



35) ADJUSTMENT OF BUCKET CLEARANCE

- (1) Lower the bucket on the ground as the picture shown in the right.
- (2) Swing to the left and keep the arm boss to be contact to the bucket left.
- (3) Lock the safety lever to the LOCK position and stop the engine.
- (4) Measure the clearance (A) between bucket and arm boss. This is the total clearance.

(5) Adjusting

- ① Loosen bolt (2), and remove washer (3), plate (1) and shim (4).
- ② Remove the shim equivalent value with measuring value.
- ③ Assemble the parts in the reverse order of removal.
 - Tightening torque : $29.6 \pm 3.2 \text{ kgf} \cdot \text{m}$
($214.0 \pm 23.1 \text{ lbf} \cdot \text{ft}$)
 - Normal clearance : $0.5 \sim 1.0 \text{ mm}$
($0.02 \sim 0.04 \text{ in}$)

※ If the bucket is not adjusted correctly, noise and vibration created during operation, and damaged O-ring, pin and bushing quickly.

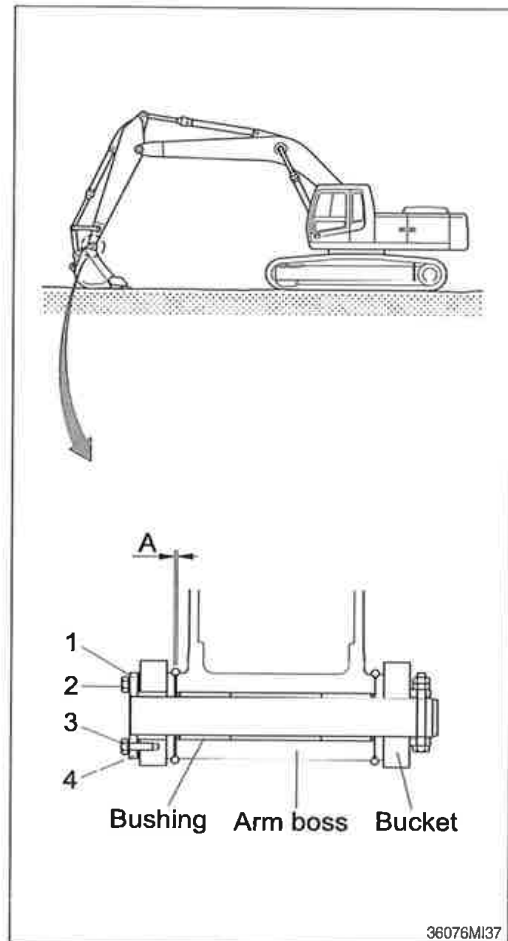



36) LUBRICATE PIN AND BUSHING

(1) Lubricate to each pin of working device

Lubricate the grease to the grease nipple according to the lubricating interval.

No.	Description	Qty
1	Lubrication manifold at boom	5
2	Boom cylinder pin	2
3	Boom and arm connection pin	1
4	Arm cylinder pin (Rod side)	1
5	Bucket cylinder pin (Head, rod)	2
	Bucket link (Control rod)	3
	Arm and control link connection pin	1
	Arm and bucket connection pin	1
6	Boom rear bearing center	1

※ Shorten lubricating interval when working in the water or dusty place.

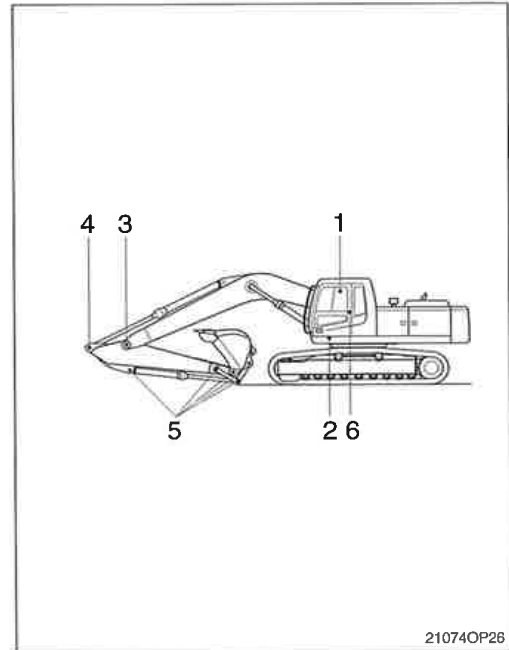

21074OP26

(2) Dust seals are mounted on the rotating part of working device to extend the lubricating interval.

※ Mount the lip to be faced outside when replace the dust seal.

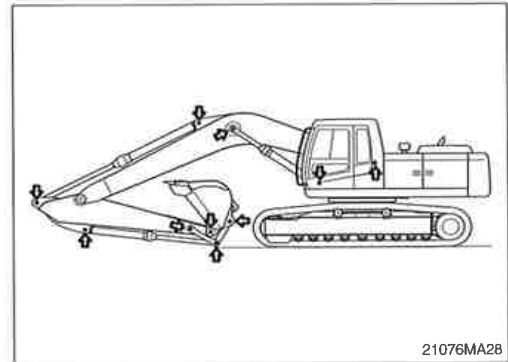

21076MA28

※ If it is assembled in wrong direction, it will cause fast wear of pin and bushing, and create noise and vibration during operation.

※ Assemble the seal same direction with picture and use with plastic hammer when replace.

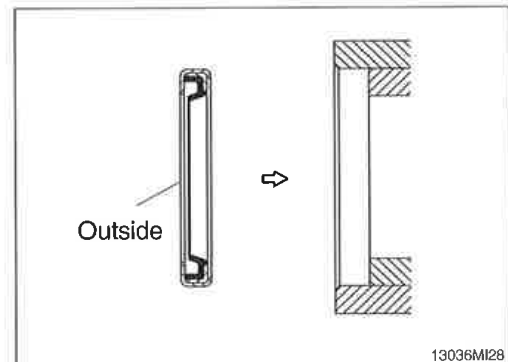

13036MI28

7. ELECTRICAL SYSTEM

1) WIRING, GAUGES

Check regularly and repair loose or malfunctioning gauges when found.

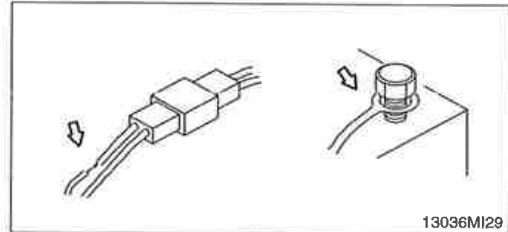

13036MI29

2) BATTERY

(1) Clean

- ① Wash the terminal with hot water if it is contaminated, and apply grease to the terminals after washing.
- ⚠ Battery gas can explode. Keep sparks and flames away from batteries.
- ⚠ Always wear protective glasses when working with batteries.
- ⚠ Do not stain clothes or skin with electrolyte as it is acid.
Be careful not to get the electrolyte in eyes.
Wash with clean water and go to the doctor if it enters the eyes.

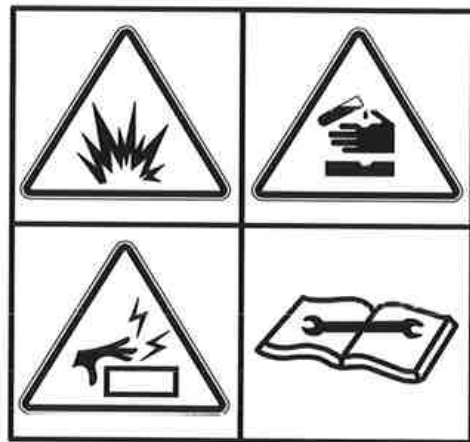

36070FW05

(2) Recycle

- Never discard a battery.
- Always return used batteries to one of the following locations.
 - A battery supplier
 - An authorized battery collection facility
 - Recycling facility

(3) Method of removing the battery cable

Remove the cable from the ground connection first (⊖ terminal side) and reconnect it last when reassembling.

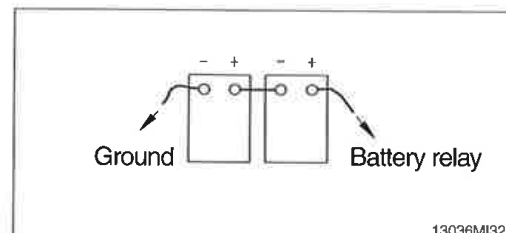

13036MI32

3) STARTING THE ENGINE WITH A BOOSTER CABLE

Keep following order when you are going to start engine using booster cable.

(1) Connection of booster cable

※ Use the same capacity of battery for starting.

- ① Make sure that the starting switches of the normal machine and trouble machine are both at the OFF position.
- ② Connect the red terminal of booster cable to the battery (+) terminal between exhausted and new battery.
- ③ Connect the black terminal of the booster cable between new battery (-) terminal and chassis of trouble machine.

※ Keep firmly all connection, the spark will be caused when connecting finally.

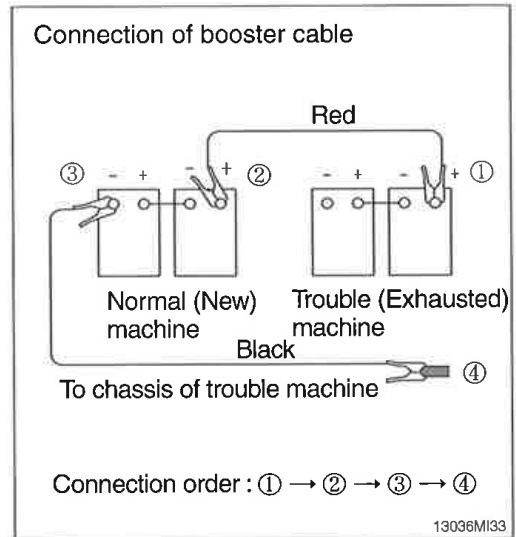

(2) Starting the engine

- ① Starting the engine of the normal machine and keep it to run at high idle.
- ② Start engine of the trouble machine with starting switch.
- ③ If you can not start it by one time, restart the engine after 2 minutes.

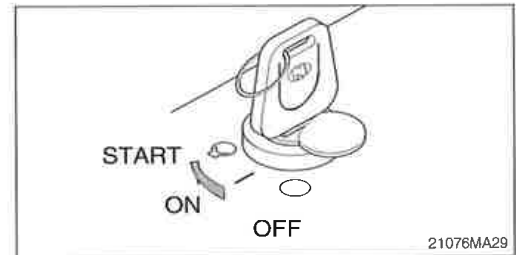

(3) Taking off the booster cable

- ① Take off the booster cable (black).
- ② Take off the booster cable (red) connected to the (+) terminal.
- ③ Run engine with high idle until charging the exhausted battery by alternator, fully.

▲ Explosive gas is generated while using the battery or charging it. Keep away flame and be careful not to cause the spark.

- ※ Charge the battery in the well ventilated place.
- ※ Place the machine on the earth or concrete. Avoid charging the machine on the steel plate.
- ※ Do not connect (+) terminal and (-) terminal when connecting booster cable because it will be shorted.

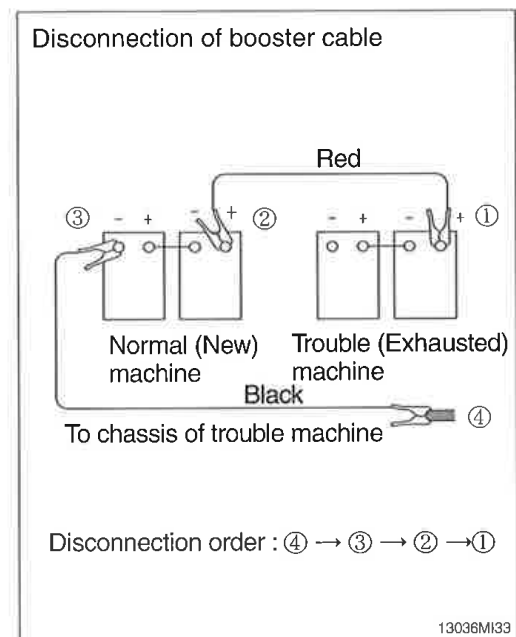



(4) Welding repair

Before start to welding, follow the below procedure.

- ① Shut off the engine and remove the starting switch.
 - ② Disconnect ground cable from battery by master switch.
 - ③ Before carrying out any electric welding on the machine, the battery cables should be disconnected and the connectors pulled out of the electronic control units (MCU, cluster etc).
 - ④ Connect the earth (ground) lead of the welding equipment as close to the welding point as possible.
- ※ Do not weld or flame cut on pipes or tubes that contain flammable fluids. Clean them thoroughly with nonflammable solvent before welding or flame cutting on them.
- ⚠ Do not attempt to welding work before carry out the above.

If not, it will caused serious damage at electric system.

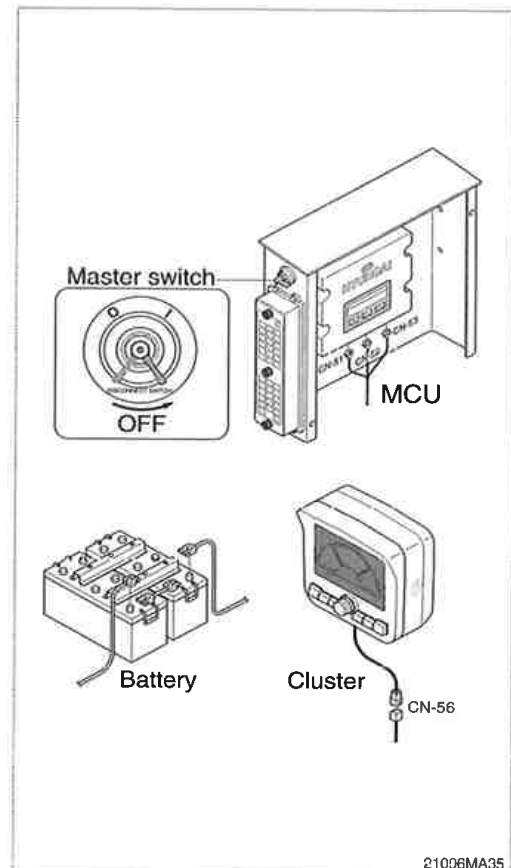

21006MA35

8. AIR CONDITIONER AND HEATER

1) CLEAN AND REPLACE OF FRESH AIR FILTER

※ Always stop the engine before servicing.

(1) Open the LH side cover.

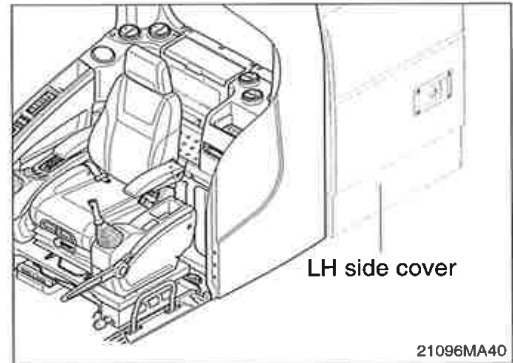

(2) Remove the fresh air filter.

※ When installing a filter, be careful not to change the filter direction.

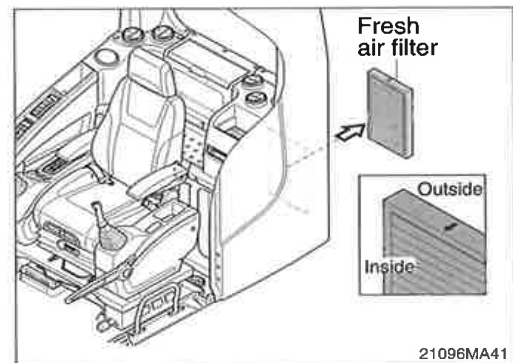

(3) Clean the filter using a pressurized air (below 2 kgf/cm², 28 psi).

△ When using pressurized air, be sure to wear safety glasses.

(4) Inspect the filter after cleaning. If it is damaged or badly contaminated, use a new filter.

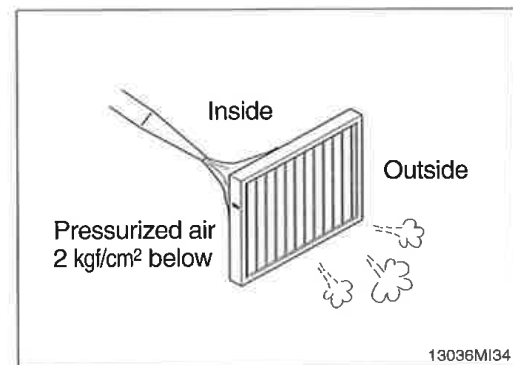

2) CLEAN AND REPLACE OF RECIRCULATION FILTER

※ Always stop the engine before servicing.

(1) Move seat and console box to arrow direction using the adjust lever.

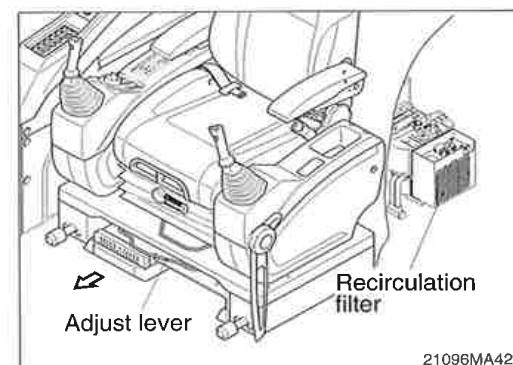

(2) Remove recirculation filter.

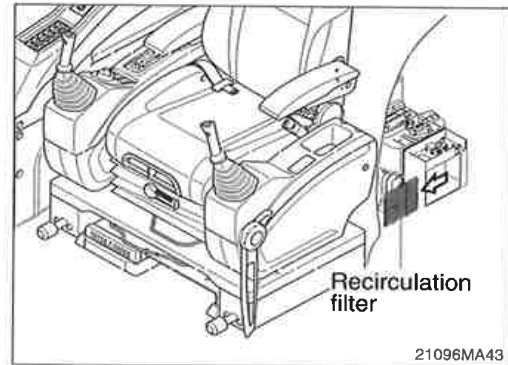

(3) Clean the recirculation filter using a pressurized air (below 2 kgf/cm², 28 psi) or washing with water.

△ When using pressurized air, be sure to wear safety glasses.

※ Dry off after washing with water.

(4) Inspect the filter after cleaning. If it is damaged or badly contaminated, use a new filter.

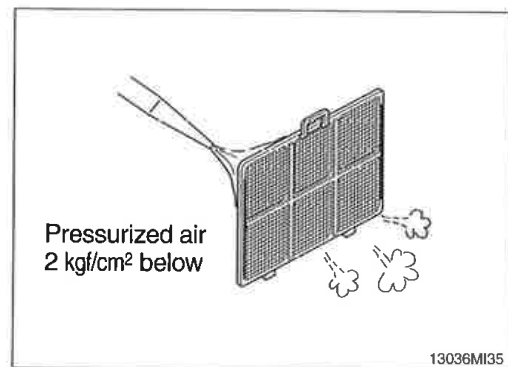

3) PRECAUTIONS FOR USING AIR CONDITIONER

(1) When using the air conditioner for a long time, open the window once every one hour.

(2) Be careful not to overcool the cab.

(3) The cab is properly cooled if the operator feels cool when entering there from outside (about 5°C lower than the outside temperature).

(4) When cooling, change air occasionally.

4) CHECK DURING SEASON

Ask the service center for replenishment of refrigerant or other maintenance service so that the cooling performance is not damaged.

5) CHECK DURING OFF-SEASON

Operate the air conditioner 2 or 3 times a month (each for a few minutes) to avoid loss of oil film in the compressor.



TROUBLESHOOTING GUIDE

1. ENGINE

※ This guide is not intended to cover every conditions, however many of the more common possibilities are listed.

Trouble	Service	Remark
The engine oil pressure lamp lights ON when engine speed is raised after completion of warm up.	<ul style="list-style-type: none"> • Add the oil to the specified level. • Replace the oil filter cartridge. • Check oil leakage from the pipe or the joint. • Replace the monitor. 	
Steam is emitted from the top part of the radiator (the pressure valve). Coolant level warning lamp lights ON.	<ul style="list-style-type: none"> • Supply the coolant and check leakage. • Adjust fan belt tension. • Wash out inside of cooling system. • Clean or repair the radiator fin. • Check the thermostat. • Tighten the radiator cap firmly or replace the packing of it. • Replace the monitor. 	
The engine does not start when the starting motor is turned over.	<ul style="list-style-type: none"> • Add fuel. • Repair where air is leaking into fuel system. • Check the injection pump or the nozzle. • Check the valve clearance. • Check engine compression pressure. • In cold weather, check if fuel warmer system is working normal. 	Refer to the pages 3-23 and 4-4.
Exhaust gas is white or blue.	<ul style="list-style-type: none"> • Adjust to specified oil quantity. • Replace with specified fuel. 	
Exhaust gas occasionally turns black.	<ul style="list-style-type: none"> • Clean or replace the air cleaner element. • Check the nozzle. • Check engine compression pressure. • Clean or replace the turbocharger. 	
Combustion noise occasionally changes to breathing sound.	<ul style="list-style-type: none"> • Check the nozzle. 	
Unusual combustion noise or mechanical noise.	<ul style="list-style-type: none"> • Check with specified fuel. • Check over-heating • Replace the muffler. • Adjust valve clearance. 	



2. ELECTRICAL SYSTEM

Trouble	Service	Remark
Lamp does not glow brightly even when engine runs at high speed. Lamp flickers while engine runs.	<ul style="list-style-type: none"> • Check for loose terminals and open-circuit wiring. • Adjust belt tension. 	
Battery charging lamp does not go out even when engine runs at high speed.	<ul style="list-style-type: none"> • Check the alternator. • Check and repair wiring. 	
Unusual noise is emitted from the alternator.	<ul style="list-style-type: none"> • Check the alternator. 	
Starting motor does not turn when starting switch is turned ON.	<ul style="list-style-type: none"> • Check and repair the wiring. • Charge the battery. • Check the starting motor. • Check the safety relay. 	
The pinion of the starting motor keeps going in and out.	<ul style="list-style-type: none"> • Charge the battery. • Check the safety relay. 	
Starting motor turns the engine sluggishly.	<ul style="list-style-type: none"> • Charge the battery. • Check the starting motor. 	
The starting motor disengages before the engine starts up.	<ul style="list-style-type: none"> • Check and repair the wiring. • Charge the battery. 	
The engine warming up lamp does not go ON.	<ul style="list-style-type: none"> • Check and repair wiring. • Check the monitor. 	
The engine oil pressure lamp does not light up when engine is stationary (when the starting switch is in ON position.)	<ul style="list-style-type: none"> • Check the monitor. • Check the caution lamp switch. 	
Battery charging lamp does not light up when the engine is stationary. (when the starting switch is in ON position.)	<ul style="list-style-type: none"> • Check the monitor. • Check and repair the wiring. 	



3. OTHERS

Trouble	Service	Remark
Track slip out of place. Excessive wear of the sprocket.	<ul style="list-style-type: none"> • Adjust tension of track. 	
Bucket either rises slowly or not at all.	<ul style="list-style-type: none"> • Add oil to specified level. 	
Slow speed of travel, swing, boom, arm and bucket.	<ul style="list-style-type: none"> • Add oil to specified level. 	
Unusual noise emitted from pump.	<ul style="list-style-type: none"> • Clean the hydraulic tank strainer. 	
Excessive oil temperature rise of hydraulic oil.	<ul style="list-style-type: none"> • Clean the oil cooler. • Adjust fan belt tension. • Add oil to specified level. 	





HYDRAULIC BREAKER AND QUICK CLAMP

1. SELECTING HYDRAULIC BREAKER

- 1) Become familiar with the manual and select breakers suitable to machine specifications.
- 2) Make careful selection in consideration of oil quantity, pressure and striking force, to enable satisfied performance.
- 3) When apply a breaker to the machine, consult your local dealer of Hyundai for further explanation.

2. CIRCUIT CONFIGURATION

- 1) As for breaker oil pressure line, use extra spool of main control valve.
- 2) Set proper breaker pressure on load relief valve.
- 3) The pressure of the ROBEX210LC-9 system is 350 kgf/cm² (4980 psi).

4) Adjusting oil quantity

- (1) Use the breaker mode from work tool of cluster.
Use select switch to control the oil flow quantity.
· Setting oil quantity (189 lpm)
- (2) If the quantity of hydraulic oil is not controlled properly, it causes short lifecycle of the breaker and the machine by increased breaking force and count.

Oil quantity setting



21098HB01

- 5) The accumulator should be used to the breaker charging and return line.
If the accumulator is not used, it will be damage as the input wave is delivered.
※ Keep the pressure pulsation of pump below 60 kgf/cm² (853 psi) by installing the accumulator.
- 6) Do not connect the breaker return line to the main control, but connect to the return line front of the cooler.
- 7) Do not connect the breaker return line to drain lines, such as of swing motor, travel motor or pump, otherwise they should be damaged.
- 8) One of spool of the main control valve should be connected to the tank.
- 9) Select the size of pipe laying considering the back pressure.
- 10) Shimless tube should be used for the piping. The hose and seal should be used Hyundai genuine parts.
- 11) Weld the bracket for pipe clamp to prevent damage caused by vibration.



3. MAINTENANCE

1) MAINTENANCE OF HYDRAULIC OIL AND FILTER

- (1) As machine with an hydraulic breaker provides the hydraulic oil becomes severely contaminated.
- (2) So, unless frequently maintained, the machine may easily go out of order.
- (3) Inspect and maintain hydraulic oil and 4 kinds of filter elements in particular, in order to prolong machine life.

2) RELEASE THE PRESSURE IN BREAKER CIRCUIT

When breaker operating is finished, stop engine and push pedal or switch for breaker to release pressure in breaker circuit.

If pressure still remains, the lifetime of the diaphragm in the accumulator will be shortened.

- 3) Be careful to prevent contamination by dust, sand and etc.
If such pollution become mixed into the oil, the pump moving parts will wear abnormally, shorten lifetime and become damaged.
- 4) When operating breaker, bolts and nuts of main equipment may be loosened by vibration. So, it must be inspected periodically.

Service interval

unit : hours

Attachment	Operating rate	Hydraulic oil	Filter element
Breaker	100 %	600* ¹	200
		1000* ²	

*¹ : Conventional hydraulic oil

*² : Hyundai genuine long life hydraulic oil

● **Replace following filter same time**

- Hydraulic return filter : 1 EA
- Pilot line filter : 1 EA
- Drain filter cartridge : 1 EA

Hyd oil change guide for hydraulic breaker

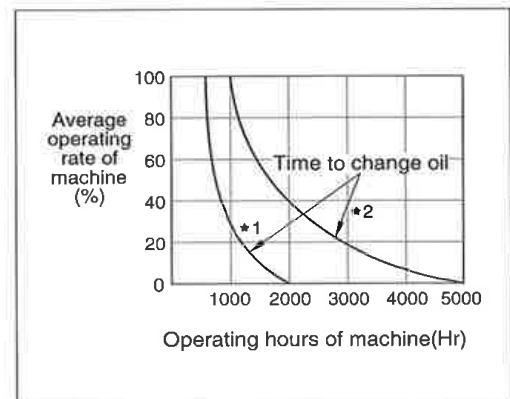

4. PRECAUTIONS WHILE OPERATING THE BREAKER

1) DO NOT BREAK ROCK WHILE LOWERING

As the breaker is heavy in comparison with bucket, it must be operated slowly.

If breaker is rapidly pushed down, working device may be damaged.

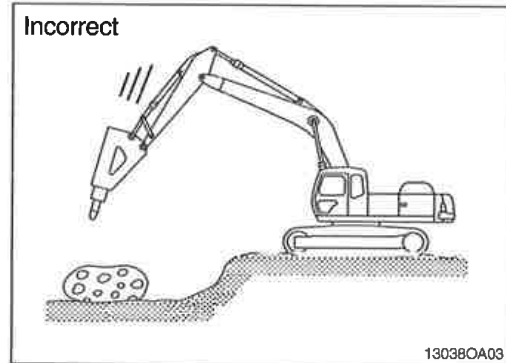

2) DO NOT USE BREAKER TO CARRY BROKEN STONE OR ROCK BY SWING OPERATING

This may damage the operation device and swing system.

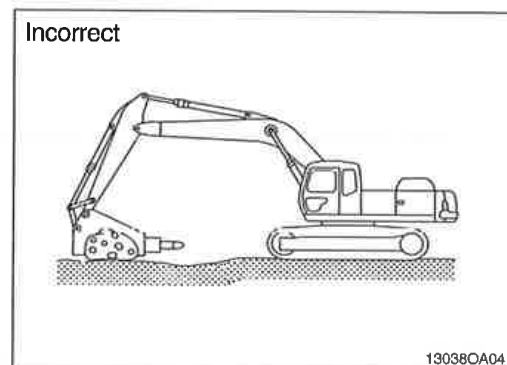

3) OPERATE BREAKER WITH A GAP IN EXCESS OF 100 mm (4 inches) FROM THE END OF THE STROKE TIP

If breaker is operated with the end tip, the cylinder may be damaged.

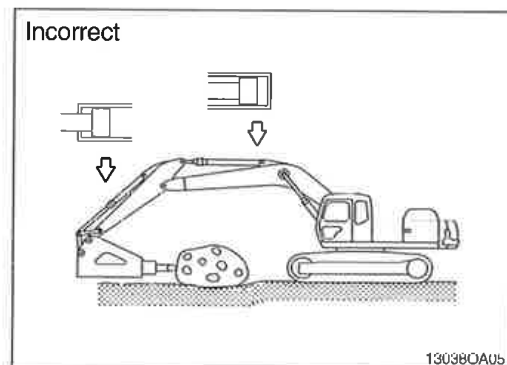

4) IF THE HYDRAULIC HOSES VIBRATE EXCESSIVELY

If the machine used in this condition continuously this will effect badly on the machine such as loosening bolt, oil leakage, damage of pump pipe and etc.

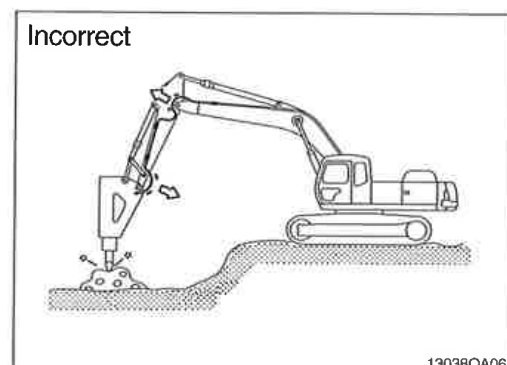



5) DO NOT CONTINUE TO WORKING OVER ONE MINUTE AT SAME POSITION OF BOOM AND ARM

This will increase the temperature of the oil, and cause problem in the accumulator and seals.

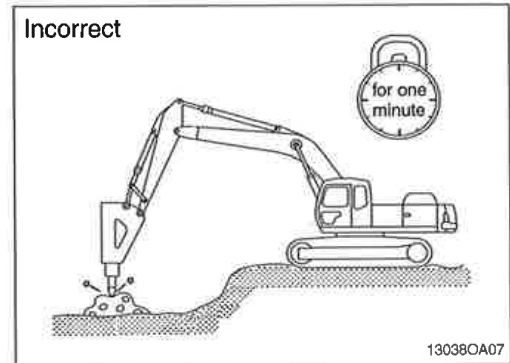

6) DO NOT MOVE MACHINE OR BREAKER WHILE STRIKING

Do not move hammer while striking.
This will cause damage to the working device and the swing system.

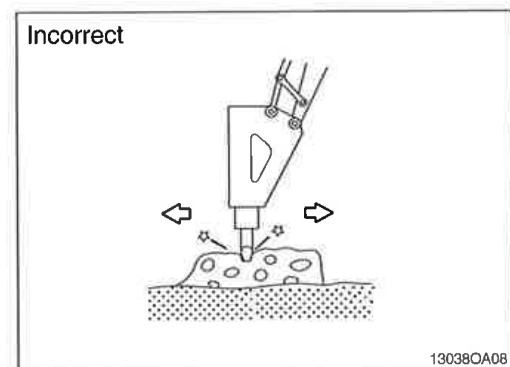

7) DO NOT WORK WHILE SWING STATE

Do not work while swing position of superstructure.
It cause the band of track shoe, oil leakage of roller.

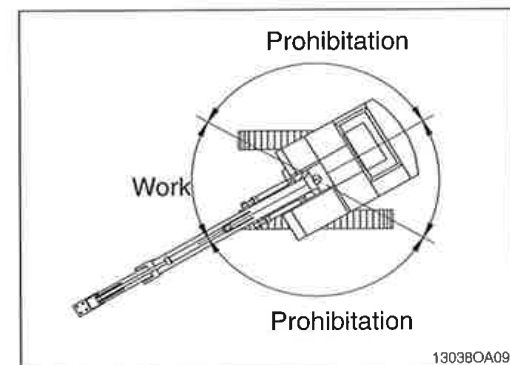

8) TAKE CARE OF CHISEL AND BOOM INTERFACE

Make sure of the arm and bucket control lever operation.

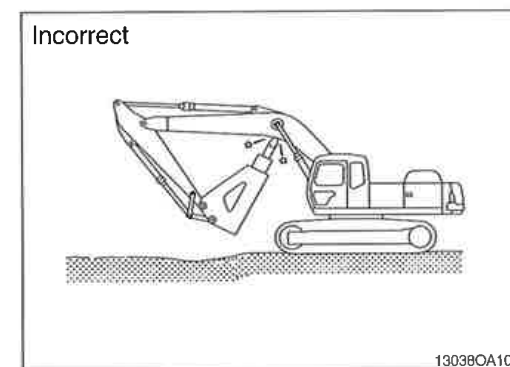

5. QUICK CLAMP

1) FIXING BUCKET WITH QUICK CLAMP

- (1) Before fixing bucket, remove safety pin of the moving hook.
- (2) Pulling safety button, press the quick clamp switch to unlock position. Then, the moving hook is placed on release position.

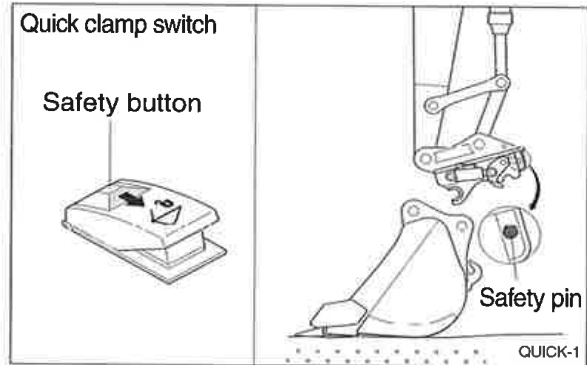

- (3) Aligning the arm and bucket, insert static hook of quick clamp to the bucket pin.

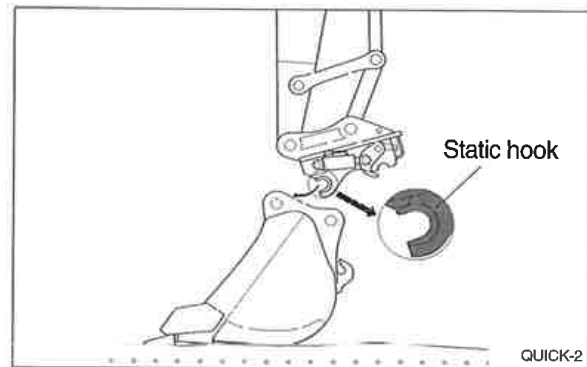

- (4) Operate RCV lever to bucket-in position. Then, the moving hook is coupled with the bucket link pin. Make sure that the moving hook is completely contacted with bucket link pin.

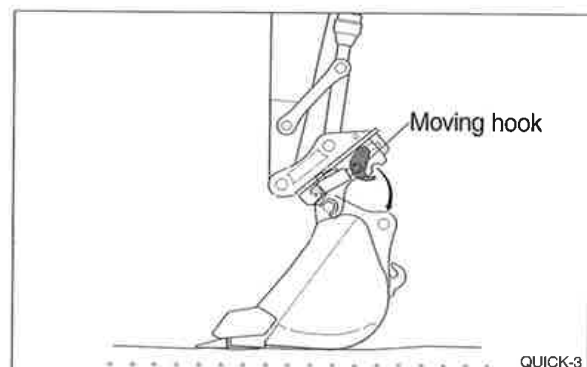

- (5) Push safety button to lock position. Operate RCV lever to bucket-in position.
 - ※ Be sure to check connection status between bucket pins and hooks of quick clamp.

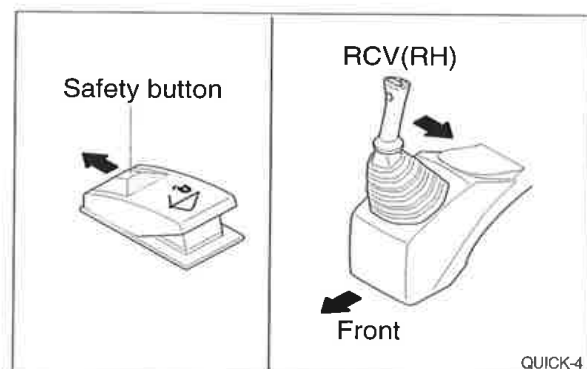

- (6) After checking the connection status between bucket pins and hooks of quick clamp, insert safety pin of moving hook to lock position.

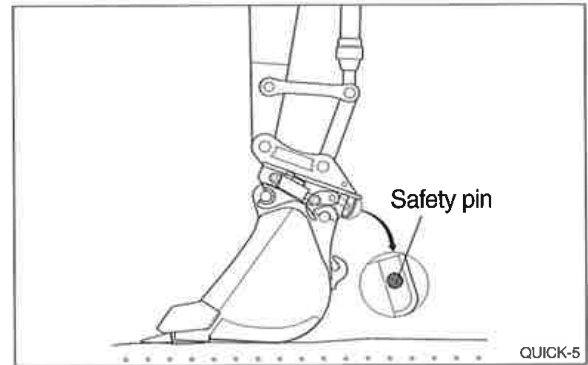

2) REMOVE BUCKET FROM QUICK CLAMP

Removing procedure is reverse of fixing.

3) PRECAUTION OF USING QUICK CLAMP

- ▲ When operating the machine with quick clamp, confirm that the quick clamp switch is lock position and safety pin of moving hook is inserted.

Operating the machine with quick clamp switch unlocked and without safety pin of moving hook can cause the bucket to drop off and bring about the accident.

- ▲ Serious injury or death can result from this accident.

- ▲ Be careful to operate the machine equipped with quick clamp. The bucket may hit cab, boom and boom cylinders when it reaches vicinity of them.

HYUNDAI will not be responsible for any injury or damage in case that safety pin is not installed properly.

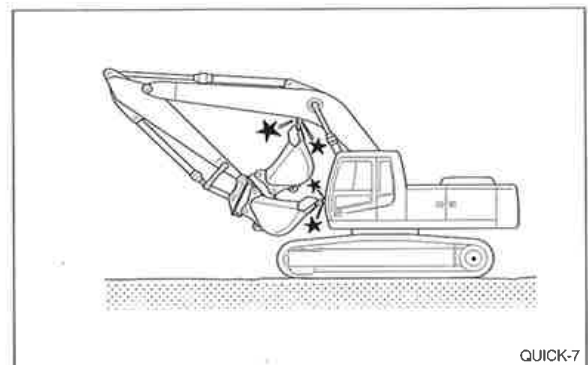
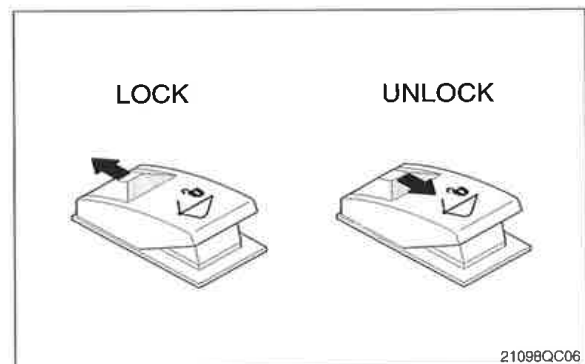





INDEX

A		G	
Accel dial switch	3-24	Gauge	3-3
After engine start	4-4	H	
Air breather element	6-32	Handsfree	3-37
Air cleaner filter	6-25	Hydraulic breaker	8-1
Air conditioner & heater	3-29	Hydraulic oil changing	6-30
Air conditioner filter	6-43	Hydraulic oil filling	6-30
Alternate exit	0-12	Hydraulic oil level	6-30
Attachment lowering	4-22	L	
B		LCD	3-5
Battery	6-40	LCD display map	3-6
Before starting engine	4-2	LCD main operation display	3-3
Boom lowering	4-22	Levers & pedals	3-27
Bucket clearance adjustment	6-38	Lifting capacities	2-9
Bucket replacement	6-36	Lubricant specification	2-26
Bucket selection guide	2-18	M	
Bucket tooth replacement	6-37	Maintenance check list	6-11
C		Major component	2-1
Cab air filter	6-43	MCU (Machine Control Unit)	3-47
Cab device	3-1	Mode selection system	4-6
Changing machine control pattern	4-25	Monitor panel	3-2
Cigar lighter	3-36	Mounting and dismounting	1-12
Cluster	3-2	N	
Coolant	6-20	New machine operation	4-1
Cooling fan	6-24	O	
CPU	3-29	Oil cooler	6-23
D		Operating pattern	4-25
Drain filter	6-32	P	
E		Pedals	3-27
Emergency engine starting connector	3-48	Periodical replacement parts	6-5
Engine oil filter	6-18	Pilot filter	6-32
Engine oil level	6-18	Pin & bushing lubrication	6-39
Engine starting & stop	4-3	Prefilter	6-26
Engine starting by booster	6-41	Pilot lamps	3-7
Engine stop	4-5	Q	
F		Quick clamp	8-6
Fan belt	6-24	R	
Fuel filter	6-27	Radiator flushing	6-20
Fuel leakage	6-29	Radio & CD/MP3 player	3-41
Fuel system bleeding	6-27		
Fuel tank	6-26		
Fuse & relay box	3-47		



RCV lever lubricate	6-35
Recommended oils	2-26, 6-10
Relieving pressure	6-3
Remote controller	3-39
Return filter	6-31
RCV lever operating pattern	4-25

S

Safety hints	1-1
Safety labels	0-5
Safety parts	6-5
Seat	3-46
Seat belt	3-46
Service meter	3-48
Service socket	3-38, 3-48
Specification for major component	2-22
Specification	2-2
Start switch	3-23
Storage	4-24
Suction strainer	6-31
Swing bearing grease	6-33
Swing gear & pinion grease	6-34
Swing reduction gear oil	6-33
Switch panel	3-23
Switches	3-9, 3-23

T

Torques-major component	6-8
Torques-fastener	6-6
Towing machine	4-14
Track adjustment	6-35
Track shoe selection	2-21
Transportation	5-1
Travel reduction gear oil	6-34
Traveling machine	4-12
Troubleshooting guide	7-1

U

Undercarriage	2-20
USB socket	3-37

W

Warming up operation	4-5
Warning lamps	3-4
Weight	2-7
Windshield	3-49
Working device operation	4-11
Working method	4-15
Working range	2-5





