



An Oshkosh Corporation Company

---

# ***Operation and Safety Manual***

*Original Instructions - Keep this manual with the machine at all times.*

## ***Boom Lift Models***

***E600***

***E600J***

***E600JP***

***M600***

***M600J***

***M600JP***





## **FOREWORD**

This manual is a very important tool! Keep it with the machine at all times.

The purpose of this manual is to provide owners, users, operators, lessors, and lessees with the precautions and operating procedures essential for the safe and proper machine operation for its intended purpose.

Due to continuous product improvements, JLG Industries, Inc. reserves the right to make specification changes without prior notification. Contact JLG Industries, Inc. for updated information.

**FOREWORD**

---

**SAFETY ALERT SYMBOLS AND SAFETY SIGNAL WORDS**

This is the Safety Alert Symbol. It is used to alert you to the potential personal injury hazards. Obey all safety messages that follow this symbol to avoid possible injury or death

**⚠ DANGER**

INDICATES AN IMMINENTLY HAZARDOUS SITUATION. IF NOT AVOIDED, WILL RESULT IN SERIOUS INJURY OR DEATH. THIS DECAL WILL HAVE A RED BACKGROUND.

**⚠ WARNING**

INDICATES A POTENTIALLY HAZARDOUS SITUATION. IF NOT AVOIDED, COULD RESULT IN SERIOUS INJURY OR DEATH. THIS DECAL WILL HAVE AN ORANGE BACKGROUND.

**⚠ CAUTION**

INDICATES A POTENTIALLY HAZARDOUS SITUATION. IF NOT AVOIDED, MAY RESULT IN MINOR OR MODERATE INJURY. IT MAY ALSO ALERT AGAINST UNSAFE PRACTICES. THIS DECAL WILL HAVE A YELLOW BACKGROUND.



## FOREWORD

### **⚠ WARNING**

**THIS PRODUCT MUST COMPLY WITH ALL SAFETY RELATED BULLETINS. CONTACT JLG INDUSTRIES, INC. OR THE LOCAL AUTHORIZED JLG REPRESENTATIVE FOR INFORMATION REGARDING SAFETY-RELATED BULLETINS WHICH MAY HAVE BEEN ISSUED FOR THIS PRODUCT.**

### **NOTICE**

**JLG INDUSTRIES, INC. SENDS SAFETY RELATED BULLETINS TO THE OWNER OF RECORD OF THIS MACHINE. CONTACT JLG INDUSTRIES, INC. TO ENSURE THAT THE CURRENT OWNER RECORDS ARE UPDATED AND ACCURATE.**

### **NOTICE**

**JLG INDUSTRIES, INC. MUST BE NOTIFIED IMMEDIATELY IN ALL INSTANCES WHERE JLG PRODUCTS HAVE BEEN INVOLVED IN AN ACCIDENT INVOLVING BODILY INJURY OR DEATH OF PERSONNEL OR WHEN SUBSTANTIAL DAMAGE HAS OCCURRED TO PERSONAL PROPERTY OR THE JLG PRODUCT.**

### **For:**

- Accident Reporting
- Product Safety Publications
- Current Owner Updates
- Questions Regarding Product Safety
- Standards and Regulations Compliance Information
- Questions Regarding Special Product Applications
- Questions Regarding Product Modifications

### **Contact:**

Product Safety and Reliability Department  
JLG Industries, Inc.  
13224 Fountainhead Plaza  
Hagerstown, MD 21742

or Your Local JLG Office  
(See addresses on inside of manual cover)

### **In USA:**

Toll Free: 877-JLG-SAFE (877-554-7233)

### **Outside USA:**

Phone: 240-420-2661  
Fax: 301-745-3713  
E-mail: ProductSafety@JLG.com



## **FOREWORD**

---

### **REVISION LOG**

Original Issue	- June 7, 2005
Revised	- July 21, 2006
Revised	- December 7, 2009
Revised	- March 2, 2010
Revised	- September 1, 2010



**TABLE OF CONTENTS**

<b>SECTION - PARAGRAPH, SUBJECT</b>	<b>PAGE</b>	<b>SECTION - PARAGRAPH, SUBJECT</b>	<b>PAGE</b>
<b>SECTION - 1 - SAFETY PRECAUTIONS</b>		<b>SECTION - 3 - MACHINE CONTROLS AND INDICATORS</b>	
1.1 GENERAL .....	1-1	3.1 GENERAL .....	3-1
1.2 PRE-OPERATION .....	1-1	3.2 CONTROLS AND INDICATORS .....	3-1
Operator Training and Knowledge .....	1-1	Ground Control Station .....	3-1
Workplace Inspection .....	1-2	Platform Control Station .....	3-6
Machine Inspection .....	1-2	Platform Control Indicator Panel .....	3-9
1.3 OPERATION .....	1-3		
General .....	1-3	<b>SECTION - 4 - MACHINE OPERATION</b>	
Trip and Fall Hazards .....	1-3	4.1 DESCRIPTION .....	4-1
Electrocution Hazards .....	1-4	4.2 OPERATING CHARACTERISTICS AND	
Tipping Hazards .....	1-6	LIMITATIONS .....	4-1
Crushing and Collision Hazards .....	1-7	Capacities .....	4-1
1.4 TOWING, LIFTING, AND HAULING .....	1-8	Stability .....	4-1
1.5 ADDITIONAL HAZARDS / SAFETY .....	1-9	4.3 MOTOR OPERATION .....	4-2
		Power/Emergency Stop .....	4-2
<b>SECTION - 2 - USER RESPONSIBILITIES, MACHINE</b>		Platform/Ground Select Switch .....	4-2
<b>PREPARATION, AND INSPECTION</b>		4.4 TRAVELING (DRIVING) .....	4-5
2.1 PERSONNEL TRAINING .....	2-1	Traveling Forward and Reverse .....	4-5
Operator Training .....	2-1	4.5 STEERING .....	4-7
Training Supervision .....	2-1	4.6 PLATFORM .....	4-7
Operator Responsibility .....	2-1	Platform Level Adjustment .....	4-7
2.2 PREPARATION, INSPECTION, AND		Platform Rotation .....	4-7
MAINTENANCE .....	2-2	4.7 BOOM .....	4-7
Pre-Start Inspection .....	2-4	Swinging the Boom .....	4-8
Function Check .....	2-5	Raising and Lowering the Upper Boom .....	4-8



## TABLE OF CONTENTS

SECTION - PARAGRAPH, SUBJECT	PAGE	SECTION - PARAGRAPH, SUBJECT	PAGE
4.8 GENERATOR (OPTIONAL) .....	4-8	5.4 EMERGENCY TOWING PROCEDURES .....	5-2
Automatic Operating Mode .....	4-8	5.5 MANUAL DESCENT SYSTEM .....	5-2
Battery Only Operating Mode .....	4-8		
Manual (Charge) Operating Mode .....	4-8	<b>SECTION - 6 - GENERAL SPECIFICATIONS &amp; OPERATOR</b>	
4.9 FUNCTION SPEED CONTROL .....	4-9	<b>MAINTENANCE</b>	
4.10 OSCILLATING AXLE LOCKOUT TEST		6.1 INTRODUCTION .....	6-1
(IF EQUIPPED) .....	4-9	6.2 OPERATING SPECIFICATIONS .....	6-1
4.11 SHUT DOWN AND PARK .....	4-9	Capacities .....	6-2
4.12 LIFTING AND TIE DOWN .....	4-10	Tires .....	6-3
Lifting .....	4-10	Hydraulic Oil .....	6-3
Tie Down .....	4-10	Major Component Weights .....	6-4
4.13 TOWING INSTRUCTIONS .....	4-12	Serial Number Location .....	6-4
4.14 DRIVE HUB .....	4-13	6.3 OPERATOR MAINTENANCE .....	6-6
Disengaging for Towing .....	4-13	6.4 OSCILLATING AXLE LOCKOUT TEST	
Engaging after Towing is Complete .....	4-15	(IF EQUIPPED) .....	6-7
		6.5 TIRES & WHEELS .....	6-9
<b>SECTION - 5 - EMERGENCY PROCEDURES</b>		Tire Inflation .....	6-9
5.1 GENERAL .....	5-1	Tire Damage .....	6-9
5.2 INCIDENT NOTIFICATION .....	5-1	Tire Replacement .....	6-9
5.3 EMERGENCY OPERATION .....	5-1	Wheel Replacement .....	6-10
Operator Unable to Control Machine .....	5-1	Wheel Installation .....	6-10
Platform or Boom Caught Overhead .....	5-2	6.6 SUPPLEMENTAL INFORMATION .....	6-11
		<b>SECTION - 7 - INSPECTION AND REPAIR LOG</b>	





**TABLE OF CONTENTS**

**SECTION - PARAGRAPH, SUBJECT PAGE**

**LIST OF FIGURES**

2-1.	Basic Nomenclature - Sheet 1 of 3 . . . . .	2-6
2-2.	Basic Nomenclature - Sheet 2 of 3 . . . . .	2-7
2-3.	Basic Nomenclature - Sheet 3 of 3 . . . . .	2-8
2-4.	Daily Walk-Around Inspection - Sheet 1 of 4 . . . . .	2-9
2-5.	Daily Walk-Around Inspection - Sheet 2 of 4 . . . . .	2-10
2-6.	Daily Walk-Around Inspection - Sheet 3 of 4 . . . . .	2-11
2-7.	Daily Walk-Around Inspection - Sheet 4 of 4 . . . . .	2-12
3-1.	Ground Control Station . . . . .	3-2
3-1.	Ground Control Station w/ Function Enable . . . . .	3-3
3-1.	Platform Control Station . . . . .	3-8
3-2.	Platform Control Indicator Panel . . . . .	3-10
4-1.	Position of Least Forward Stability . . . . .	4-3
4-2.	Position of Least Backward Stability . . . . .	4-4
4-3.	Grade and Side Slopes . . . . .	4-6
4-4.	Lifting and Tie Down Chart . . . . .	4-11
4-5.	Decal Installation - Sheet 1 of 4 . . . . .	4-16
4-6.	Decal Installation - Sheet 2 of 4 . . . . .	4-17
4-7.	Decal Installation - Sheet 3 of 4 . . . . .	4-18
4-8.	Decal Installation - Sheet 4 of 4 . . . . .	4-19
5-1.	Manual Descent Decal . . . . .	5-5
6-1.	Serial Number Location . . . . .	6-4
6-2.	Operator Maintenance and Lubrication Diagram . . . . .	6-5

**SECTION - PARAGRAPH, SUBJECT PAGE**

**LIST OF TABLES**

1-1	Minimum Approach Distances (M.A.D.) . . . . .	1-5
1-2	Beaufort Scale (For Reference Only) . . . . .	1-10
2-1	Inspection and Maintenance Table . . . . .	2-3
6-1	Operating Specifications . . . . .	6-1
6-2	Capacities . . . . .	6-2
6-3	Tires . . . . .	6-3
6-4	Hydraulic Oil . . . . .	6-3
6-5	Mobil DTE 11M Specs . . . . .	6-3
6-6	Component Weights . . . . .	6-4
6-7	Lubrication Specifications . . . . .	6-6
6-8	Wheel Torque Chart . . . . .	6-11
7-1	Inspection and Repair Log . . . . .	7-1



## TABLE OF CONTENTS

---

**SECTION - PARAGRAPH, SUBJECT**

**PAGE**

**SECTION - PARAGRAPH, SUBJECT**

**PAGE**

**This page left blank intentionally.**



## SECTION 1 - SAFETY PRECAUTIONS

# SECTION 1. SAFETY PRECAUTIONS

## 1.1 GENERAL

This section outlines the necessary precautions for proper and safe machine operation and maintenance. For proper machine use, it is mandatory that a daily routine is established based on the content of this manual. A maintenance program, using the information provided in this manual and the Service and Maintenance Manual, must also be established by a qualified person and followed to ensure the machine is safe to operate.

The owner/user/operator/lessor/lessee of the machine should not operate the machine until this manual has been read, training is accomplished, and operation of the machine has been completed under the supervision of an experienced and qualified operator.

If there are any questions with regard to safety, training, inspection, maintenance, application, and operation, please contact JLG Industries, Inc. (“JLG”).

### **WARNING**

**FAILURE TO COMPLY WITH THE SAFETY PRECAUTIONS LISTED IN THIS MANUAL COULD RESULT IN MACHINE DAMAGE, PROPERTY DAMAGE, PERSONAL INJURY OR DEATH.**

## 1.2 PRE-OPERATION

### Operator Training and Knowledge

- Read and understand this manual before operating the machine.

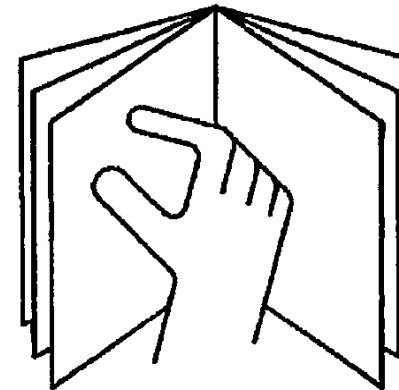

- Do not operate this machine until complete training is performed by authorized persons.
- Only authorized and qualified personnel can operate the machine.



## SECTION 1 - SAFETY PRECAUTIONS

- Read, understand, and obey all DANGERS, WARNINGS, CAUTIONS, and operating instructions on the machine and in this manual.
- Use the machine in a manner which is within the scope of its intended application set by JLG.
- All operating personnel must be familiar with the emergency controls and emergency operation of the machine as specified in this manual.
- Read, understand, and obey all applicable employer, local, and governmental regulations as they pertain to operation of the machine.

### Workplace Inspection

- The operator is to take safety measures to avoid all hazards in the work area prior to machine operation.
- Do not operate or raise the platform while on trucks, trailers, railway cars, floating vessels, scaffolds or other equipment unless approved in writing by JLG.
- Do not operate the machine in hazardous environments unless approved for that purpose by JLG.
- Be sure that the ground conditions are able to support the maximum load shown on the decals located on the machine.

- This machine can be operated in temperatures of 0° F to 104° F (-20° C to 40° C). Consult JLG for operation outside this range.

### Machine Inspection

- Before machine operation, perform inspections and functional checks. Refer to Section 2 of this manual for detailed instructions.
- Do not operate this machine until it has been serviced and maintained according to requirements specified in the Service and Maintenance Manual.
- Be sure the footswitch and all other safety devices are operating properly. Modification of these devices is a safety violation.

### **WARNING**

**MODIFICATION OR ALTERATION OF AN AERIAL WORK PLATFORM SHALL BE MADE ONLY WITH WRITTEN PERMISSION FROM THE MANUFACTURER**

- Do not operate any machine on which safety or instruction placards or decals are missing or illegible.
- Avoid any buildup of debris on the platform floor. Keep mud, oil, grease, and other slippery substances from footwear and platform floor.



## SECTION 1 - SAFETY PRECAUTIONS

### 1.3 OPERATION

#### General

- Do not use the machine for any purpose other than positioning personnel, their tools, and equipment.
  - Never operate a machine that is not working properly. If a malfunction occurs, shut down the machine.
  - Never slam a control switch or lever through neutral to an opposite direction. Always return switch to neutral and stop before moving the switch to the next function. Operate controls with slow and even pressure.
  - Do not allow personnel to tamper with or operate the machine from the ground with personnel in the platform, except in an emergency.
  - Do not carry materials directly on platform railing. Contact JLG for approved material handling accessories.
  - When two or more persons are in the platform, the operator shall be responsible for all machine operations.
  - Always ensure that power tools are properly stowed and never left hanging by their cord from the platform work area.
- Supplies or tools which extend outside the platform are prohibited unless approved by JLG.
  - When driving, always position boom over rear axle in line with the direction of travel. Remember, if boom is over the front axle, steer and drive functions will be reversed.
  - Do not assist a stuck or disabled machine by pushing, pulling, or by using boom functions. Only pull the unit from the tie-down lugs on the chassis.
  - Do not place boom or platform against any structure to steady the platform or to support the structure.
  - Stow boom and shut off all power before leaving machine.

#### Trip and Fall Hazards

During operation, occupants in the platform must wear a full body harness with a lanyard attached to an authorized lanyard anchorage point. Attach only one (1) lanyard per lanyard anchorage point.

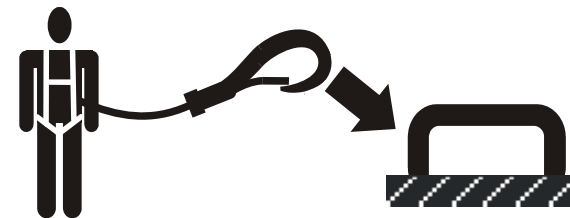



## SECTION 1 - SAFETY PRECAUTIONS

- Before operating the machine, make sure all gates are closed and fastened in their proper position.

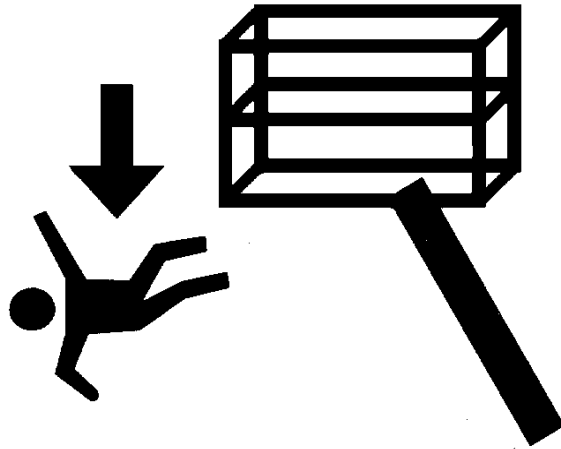

- Keep both feet firmly positioned on the platform floor at all times. Never use ladders, boxes, steps, planks, or similar items on platform to provide additional reach.
- Never use the boom assembly to enter or leave the platform.

- Use extreme caution when entering or leaving platform. Be sure that the boom is fully lowered. It may be necessary to telescope out to position the platform closer to the ground for entry/exit. Face the machine, maintain “three point contact” with the machine, using two hands and one foot or two feet and one hand during entry and exit.

### Electrocution Hazards

- This machine is not insulated and does not provide protection from contact or proximity to electrical current.

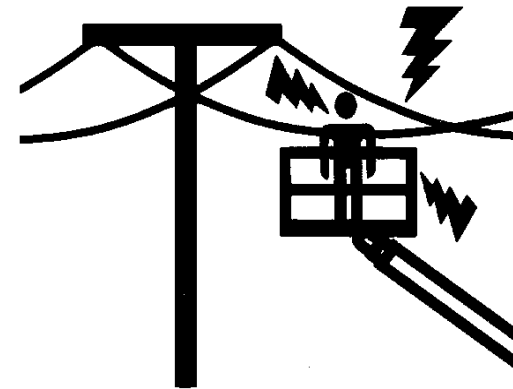



## SECTION 1 - SAFETY PRECAUTIONS

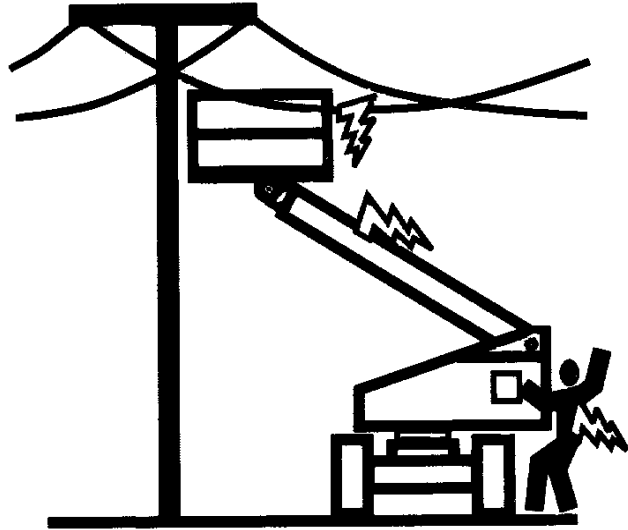

- Maintain distance from electrical lines, apparatus, or any energized (exposed or insulated) parts according to the Minimum Approach Distance (MAD) as shown in Table 1-1.
- Allow for machine movement and electrical line swaying.

Table 1-1. Minimum Approach Distances (M.A.D.)

Voltage Range (Phase to Phase)	MINIMUM APPROACH DISTANCE in Feet (Meters)
0 to 50 KV	10 (3)
Over 50KV to 200 KV	15 (5)
Over 200 KV to 350 KV	20 (6)
Over 350 KV to 500 KV	25 (8)
Over 500 KV to 750 KV	35 (11)
Over 750 KV to 1000 KV	45 (14)

**NOTE:** *This requirement shall apply except where employer, local or governmental regulations are more stringent.*

- Maintain a clearance of at least 10 ft. (3m) between any part of the machine and its occupants, their tools, and their equipment from any electrical line or apparatus carrying up to 50,000 volts. One foot additional clearance is required for every additional 30,000 volts or less.



## SECTION 1 - SAFETY PRECAUTIONS

- The minimum approach distance may be reduced if insulating barriers are installed to prevent contact, and the barriers are rated for the voltage of the line being guarded. These barriers shall not be part of (or attached to) the machine. The minimum approach distance shall be reduced to a distance within the designed working dimensions of the insulating barrier. This determination shall be made by a qualified person in accordance with the employer, local, or governmental requirements for work practices near energized equipment

### **⚠ DANGER**

**DO NOT MANEUVER MACHINE OR PERSONNEL INSIDE PROHIBITED ZONE (MAD). ASSUME ALL ELECTRICAL PARTS AND WIRING ARE ENERGIZED UNLESS KNOWN OTHERWISE.**

## Tipping Hazards

- The user must be familiar with the surface before driving. Do not exceed the allowable sideslope and grade while driving.

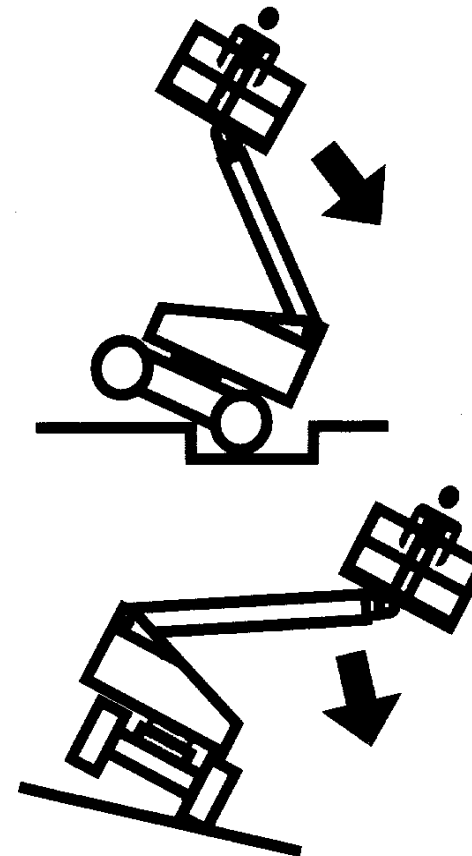





## SECTION 1 - SAFETY PRECAUTIONS

- Do not elevate platform or drive with platform elevated while on a sloping, uneven, or soft surface.
- Before driving on floors, bridges, trucks, and other surfaces, check allowable capacity of the surfaces.
- Never exceed the maximum platform capacity. Distribute loads evenly on platform floor.
- Do not raise the platform or drive from an elevated position unless the machine is on firm, level and smooth surfaces.
- Keep the chassis of the machine at least 2 ft. (0.6m) from holes, bumps, drop-offs, obstructions, debris, concealed holes, and other potential hazards on the floor/surface.
- Do not push or pull any object with the boom.
- Never attempt to use the machine as a crane. Do not tie-off machine to any adjacent structure.
- Do not operate the machine when wind conditions exceed 28 mph (12.5 m/s). Refer to Table 1-2, Beaufort Scale (For Reference Only).
- Do not increase the surface area of the platform or the load. Increase of the area exposed to the wind will decrease stability.
- Do not increase the platform size with unauthorized deck extensions or attachments.

- If boom assembly or platform is in a position that one or more wheels are off the ground, all persons must be removed before attempting to stabilize the machine. Use cranes, forklift trucks, or other appropriate equipment to stabilize machine.

### Crushing and Collision Hazards

- Approved head gear must be worn by all operating and ground personnel.
- Check work area for clearances overhead, on sides, and bottom of platform when lifting or lowering platform, and driving.

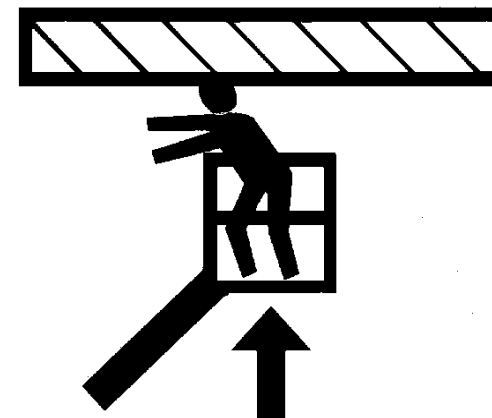

- During operation, keep all body parts inside platform railing.



## SECTION 1 - SAFETY PRECAUTIONS

---

- Use the boom functions, not the drive function, to position the platform close to obstacles.
- Always post a lookout when driving in areas where vision is obstructed.
- Keep non-operating personnel at least 6 ft. (1.8m) away from machine during all driving and swing operations.
- Limit travel speed according to conditions of ground surface, congestion, visibility, slope, location of personnel, and other factors which may cause collision or injury to personnel.
- Be aware of stopping distances in all drive speeds. When driving in high speed, switch to low speed before stopping. Travel grades in low speed only.
- Do not use high speed drive in restricted or close quarters or when driving in reverse.
- Exercise extreme caution at all times to prevent obstacles from striking or interfering with operating controls and persons in the platform.
- Be sure that operators of other overhead and floor level machines are aware of the aerial work platform's presence. Disconnect power to overhead cranes.
- Warn personnel not to work, stand, or walk under a raised boom or platform. Position barricades on floor if necessary.

### 1.4 TOWING, LIFTING, AND HAULING

- Never allow personnel in platform while towing, lifting, or hauling.
- This machine should not be towed, except in the event of emergency, malfunction, power failure, or loading/unloading. Refer to the Emergency Procedures section of this manual for emergency towing procedures.
- Ensure boom is in the stowed position and the turntable locked prior to towing, lifting or hauling. The platform must be completely empty of tools.
- When lifting machine, lift only at designated areas of the machine. Lift the unit with equipment of adequate capacity.
- Refer to the Machine Operation section of this manual for lifting information.



## SECTION 1 - SAFETY PRECAUTIONS

---

### 1.5 ADDITIONAL HAZARDS / SAFETY

- Do not use machine as a ground for welding.
- When performing welding or metal cutting operations, precautions must be taken to protect the chassis from direct exposure to weld and metal cutting spatter.
- Do not refuel the machine with the engine running.
- Battery fluid is highly corrosive. Avoid contact with skin and clothing at all times.
- Charge batteries only in a well ventilated area.



## SECTION 1 - SAFETY PRECAUTIONS

### **NOTICE**

**DO NOT OPERATE THE MACHINE WHEN WIND CONDITIONS EXCEED 28 MPH (12.5 M/S).**

**Table 1-2. Beaufort Scale (For Reference Only)**

Beaufort Number	Wind Speed		Description	Land Conditions
	mph	m/s		
0	0	0-0.2	Calm	Calm. Smoke rises vertically
1	1-3	0.3-1.5	Light air	Wind motion visible in smoke
2	4-7	1.6-3.3	Light breeze	Wind felt on exposed skin. Leaves rustle
3	8-12	3.4-5.4	Gentle breeze	Leaves and smaller twigs in constant motion
4	13-18	5.5-7.9	Moderate breeze	Dust and loose paper raised. Small branches begin to move.
5	19-24	8.0-10.7	Fresh breeze	Smaller trees sway.
6	25-31	10.8-13.8	Strong breeze	Large branches in motion. Whistling heard in overhead wires. Umbrella use becomes difficult.
7	32-38	13.9-17.1	Near Gale/Moderate Gale	Whole trees in motion. Effort needed to walk against the wind.
8	39-46	17.2-20.7	Fresh Gale	Twigs broken from trees. Cars veer on road.
9	47-54	20.8-24.4	Strong Gale	Light structure damage.



## SECTION 2 - USER RESPONSIBILITIES, MACHINE PREPARATION, AND INSPECTION

# SECTION 2. USER RESPONSIBILITIES, MACHINE PREPARATION, AND INSPECTION

## 2.1 PERSONNEL TRAINING

The aerial platform is a personnel handling device; so it is necessary that it be operated and maintained only by trained personnel.

Persons under the influence of drugs or alcohol or who are subject to seizures, dizziness or loss of physical control must not operate this machine.

### Operator Training

Operator training must cover:

1. Use and limitations of the controls in the platform and at the ground, emergency controls and safety systems.
2. Control labels, instructions, and warnings on the machine.
3. Rules of the employer and government regulations.
4. Use of approved fall protection device.
5. Enough knowledge of the mechanical operation of the machine to recognize a malfunction or potential malfunction.

6. The safest means to operate the machine where overhead obstructions, other moving equipment, and obstacles, depressions, holes, dropoffs.
7. Means to avoid the hazards of unprotected electrical conductors.
8. Specific job requirements or machine application.

### Training Supervision

Training must be done under the supervision of a qualified person in an open area free of obstructions until the trainee has developed the ability to safely control and operate the machine.

### Operator Responsibility

The operator must be instructed that he/she has the responsibility and authority to shut down the machine in case of a malfunction or other unsafe condition of either the machine or the job site.



## **SECTION 2 - USER RESPONSIBILITIES, MACHINE PREPARATION, AND INSPECTION**

---

### **2.2 PREPARATION, INSPECTION, AND MAINTENANCE**

The following table covers the periodic machine inspections and maintenance recommended by JLG Industries, Inc. Consult local regulations for further requirements for aerial work platforms. The frequency of inspections and maintenance must be increased as necessary when the machine is used in a harsh or hostile environment, if the machine is used with increased frequency, or if the machine is used in a severe manner.

#### **NOTICE**

**JLG INDUSTRIES, INC. RECOGNIZES A FACTORY-TRAINED SERVICE TECHNICIAN AS A PERSON WHO HAS SUCCESSFULLY COMPLETED THE JLG SERVICE TRAINING SCHOOL FOR THE SPECIFIC JLG PRODUCT MODEL.**



## SECTION 2 - USER RESPONSIBILITIES, MACHINE PREPARATION, AND INSPECTION

**Table 2-1. Inspection and Maintenance Table**

Type	Frequency	Primary Responsibility	Service Qualification	Reference
Pre-Start Inspection	Before using each day; or whenever there's an Operator change.	User or Operator	User or Operator	Operator and Safety Manual
Pre-Delivery Inspection (See Note)	Before each sale, lease, or rental delivery.	Owner, Dealer, or User	Qualified JLG Mechanic	Service and Maintenance Manual and applicable JLG inspection form
Frequent Inspection	In service for 3 months or 150 hours, whichever comes first; or Out of service for a period of more than 3 months; or Purchased used.	Owner, Dealer, or User	Qualified JLG Mechanic	Service and Maintenance Manual and applicable JLG inspection form
Annual Machine Inspection	Annually, no later than 13 months from the date of prior inspection.	Owner, Dealer, or User	Factory Trained Service Technician (Recommended)	Service and Maintenance Manual and applicable JLG inspection form
Preventative Maintenance	At intervals as specified in the Service and Maintenance Manual.	Owner, Dealer, or User	Qualified JLG Mechanic	Service and Maintenance Manual

**NOTE:** Inspection forms are available from JLG. Use the Service and Maintenance Manual to perform inspections.



## SECTION 2 - USER RESPONSIBILITIES, MACHINE PREPARATION, AND INSPECTION

### Pre-Start Inspection

The Pre-Start Inspection should include each of the following:

1. **Cleanliness** – Check all surfaces for leakage (oil, fuel, or battery fluid) or foreign objects. Report any leakage to the proper maintenance personnel.
2. **Decals and Placards** – Check all for cleanliness and legibility. Make sure none of the decals and placards are missing. Make sure all illegible decals and placards are cleaned or replaced.
3. **Operators and Safety Manuals** – Make sure a copy of the Operator and Safety Manual, EMI Safety Manual (Domestic only), and ANSI Manual of Responsibilities (Domestic only) is enclosed in the weather resistant storage container.
4. **“Walk-Around” Inspection** – Refer to Figure 2-4., Figure 2-5., and Figure 2-7.
5. **Battery** – Charge as required.
6. **Fuel** (Combustion Engine Powered Machines) – Add the proper fuel as necessary.
7. **Hydraulic Oil** – Check the hydraulic oil level. Ensure hydraulic oil is added as required.
8. **Function Check** – Once the “Walk-Around” Inspection is complete, perform a functional check of all systems in an area free of overhead and ground level obstructions. Refer to Section 4 for more specific instructions.

### **WARNING**

**IF THE MACHINE DOES NOT OPERATE PROPERLY, TURN OFF THE MACHINE IMMEDIATELY! REPORT THE PROBLEM TO THE PROPER MAINTENANCE PERSONNEL. DO NOT OPERATE THE MACHINE UNTIL IT IS DECLARED SAFE FOR OPERATION.**





## SECTION 2 - USER RESPONSIBILITIES, MACHINE PREPARATION, AND INSPECTION

### Function Check

Perform the Function Check as follows:

1. From the ground control panel with no load in the platform:
  - a. Check that all guards protecting the switches or locks are in place.
  - b. Operate all functions and check all limiting and cut-out switches.
  - c. Check auxiliary power (or manual descent).
  - d. Ensure that all machine functions are disabled when the Emergency Stop Button is activated.
2. From the platform control console:
  - a. Ensure that the control console is firmly secured in the proper location;
  - b. Check that all guards protecting the switches or locks are in place;
  - c. Operate all functions and check all limiting and cut-out switches;
  - d. Ensure that all machine functions are disabled when the Emergency Stop Button is pushed in.
  - e. With machine in the transport (stowed) position, drive on a grade (not to exceed the rated gradeability) and stop to ensure the brakes hold;
  - f. With machine in the transport (stowed) position, check the tilt sensor indicator light to ensure proper operation.

## SECTION 2 - USER RESPONSIBILITIES, MACHINE PREPARATION, AND INSPECTION

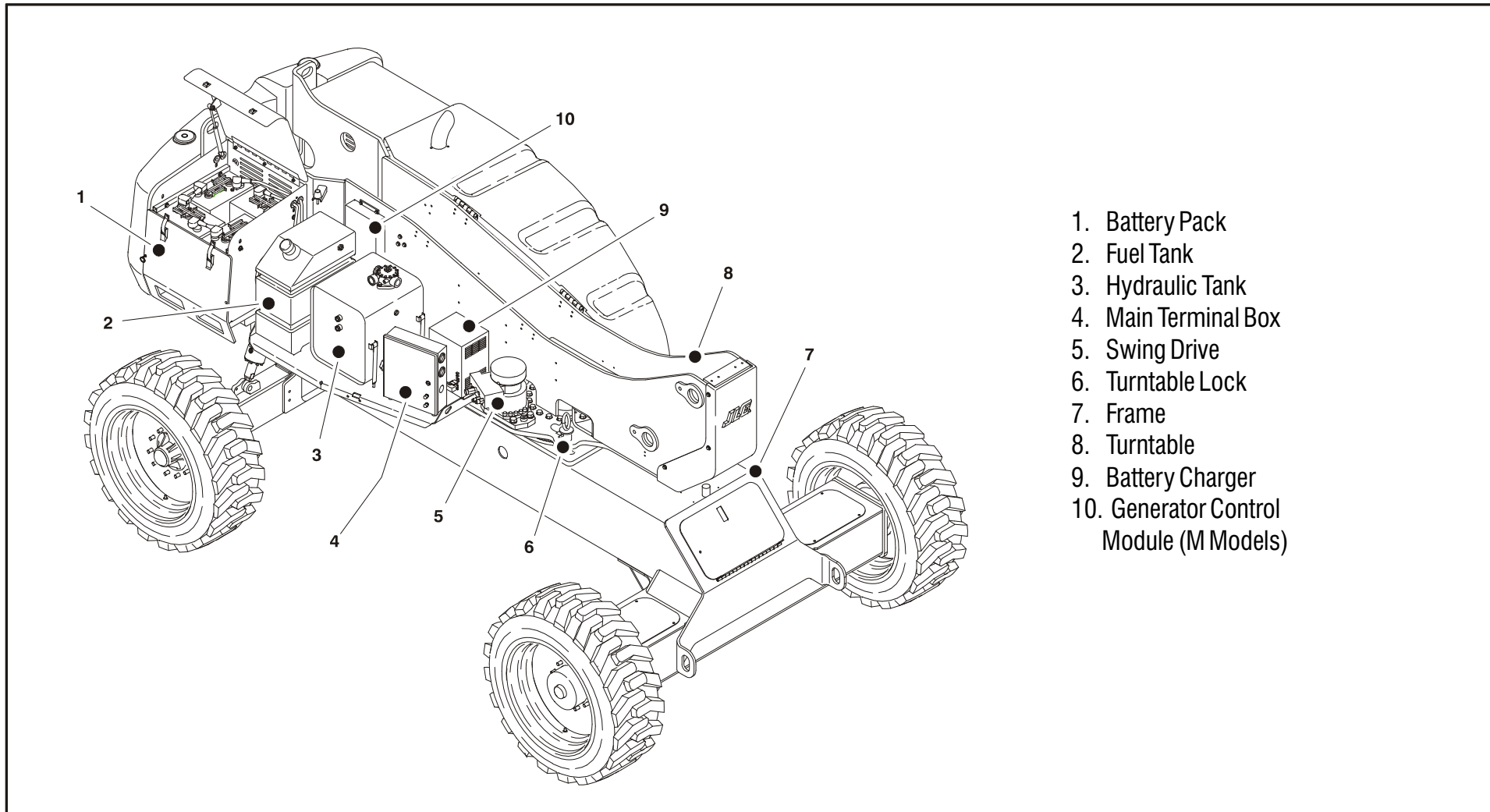

Figure 2-1. Basic Nomenclature - Sheet 1 of 3



## SECTION 2 - USER RESPONSIBILITIES, MACHINE PREPARATION, AND INSPECTION

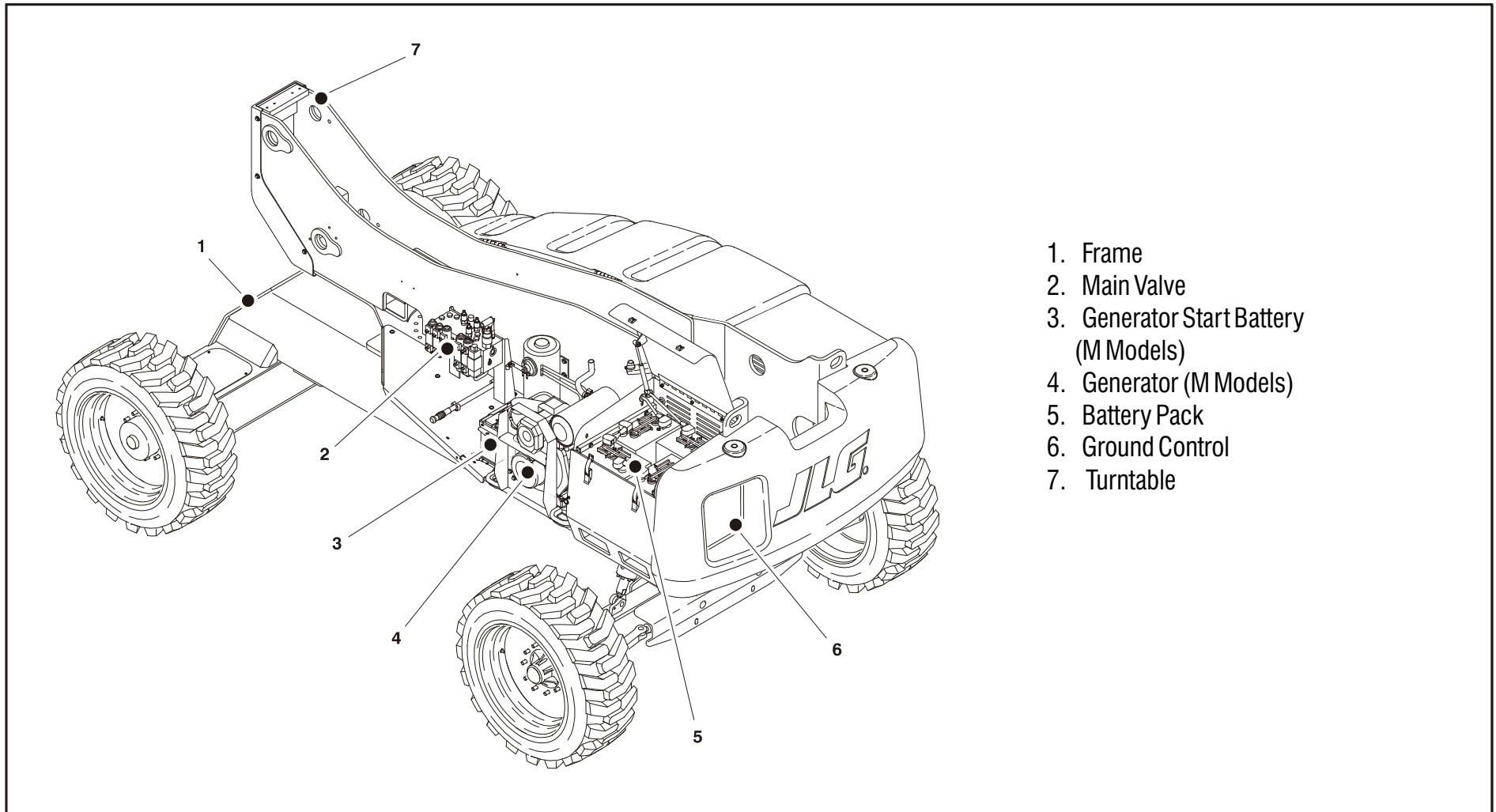

Figure 2-2. Basic Nomenclature - Sheet 2 of 3

## SECTION 2 - USER RESPONSIBILITIES, MACHINE PREPARATION, AND INSPECTION

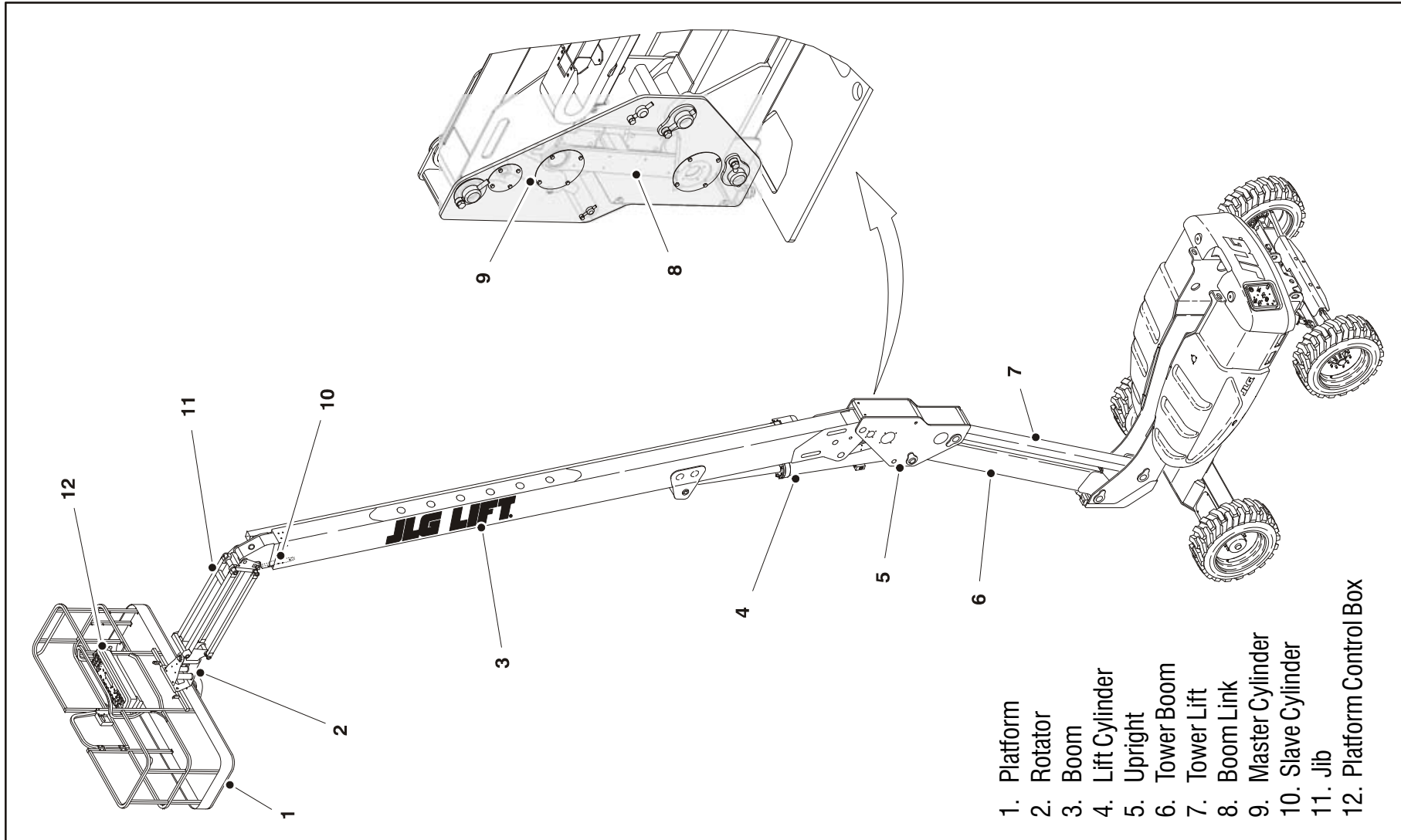

Figure 2-3. Basic Nomenclature - Sheet 3 of 3

## SECTION 2 - USER RESPONSIBILITIES, MACHINE PREPARATION, AND INSPECTION

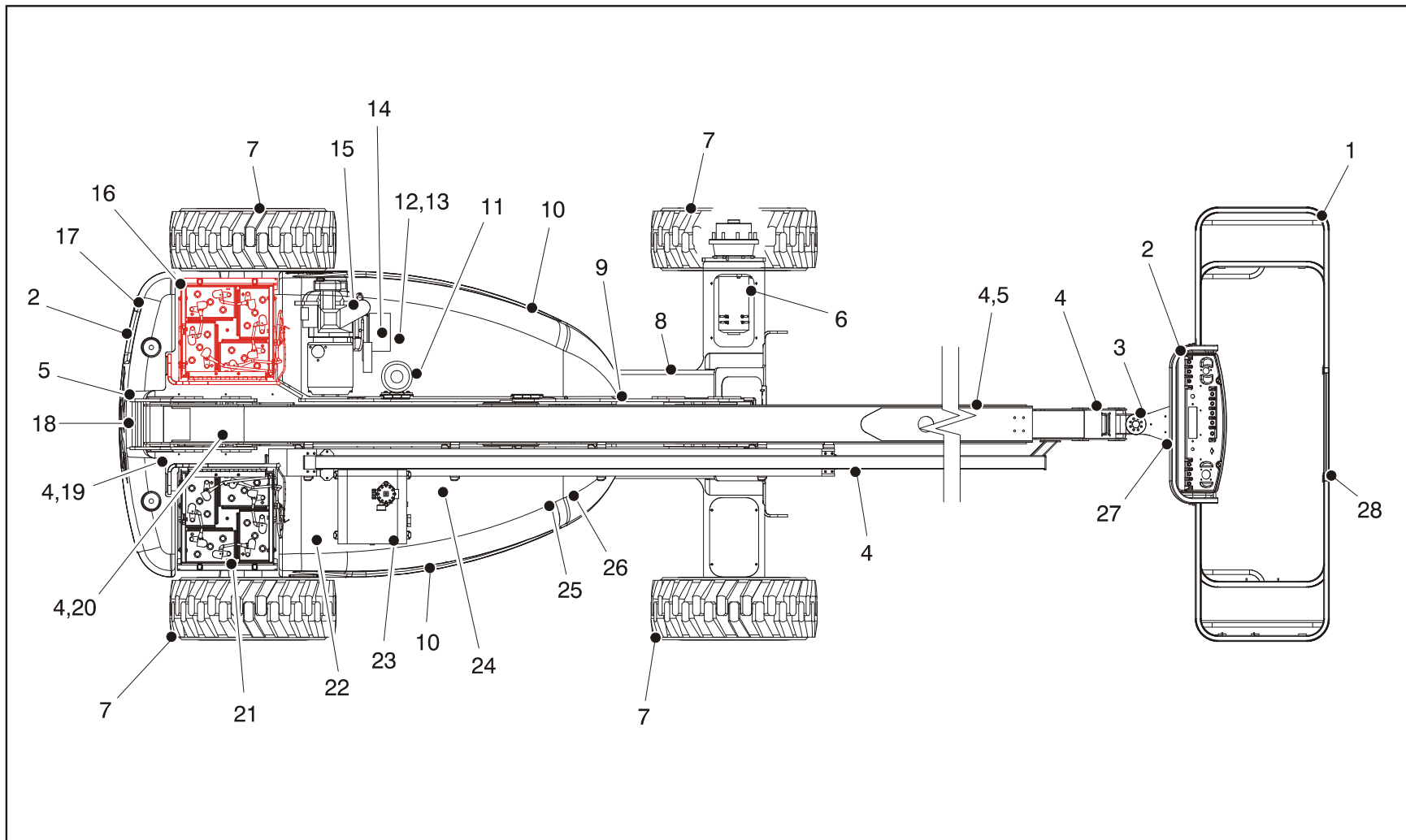

Figure 2-4. Daily Walk-Around Inspection - Sheet 1 of 4



## SECTION 2 - USER RESPONSIBILITIES, MACHINE PREPARATION, AND INSPECTION

### GENERAL

Begin your Walk-Around Inspection at item 1, as noted on the diagram. Continue to your right (counterclockwise viewed from the top) checking each item in sequence for the conditions listed in the following checklist.

### **⚠ WARNING**

**TO AVOID POSSIBLE INJURY BE SURE MACHINE POWER IS OFF DURING "WALK-AROUND INSPECTION".**

### **NOTICE**

**DO NOT OVERLOOK VISUAL INSPECTION OF CHASSIS UNDERSIDE. CHECKING THIS AREA MAY RESULT IN DISCOVERY OF CONDITIONS WHICH COULD CAUSE EXTENSIVE MACHINE DAMAGE.**

**NOTE:** *On each item, make sure there are no loose or missing parts, that they are securely fastened and that no visible damage exists in addition to any other criteria mentioned.*

1. Platform Assembly - Platform mounting pins secure. Footswitch in good working order; not modified, disabled or blocked.

2. Platform & Ground Control Console - Switches and control levers; placards secure and legible; control lever and switches return to neutral; control lever lock functions properly; emergency stop switch functions properly; control markings legible.
3. Rotator Cylinder - Motor and cylinder pins secure; hydraulic hoses.
4. All Hydraulic Cylinders - No visible damage; Pivot pins and hydraulic hoses undamaged, not leaking.
5. Boom - Pivot pins secure; Upright in vertical position. See Note.
6. Drive Axle and Motor - See Note
7. Wheel/Tire Assembly - No loose or missing lug nuts, proper inflation (pneumatic). Inspect for worn tread, cuts, tears, or other discrepancies. Inspect wheels for damage and corrosion
8. Frame (top and underside) - See Note.

Figure 2-5. Daily Walk-Around Inspection - Sheet 2 of 4



## SECTION 2 - USER RESPONSIBILITIES, MACHINE PREPARATION, AND INSPECTION

### 9. Boom Limit Switch - Switch operable;

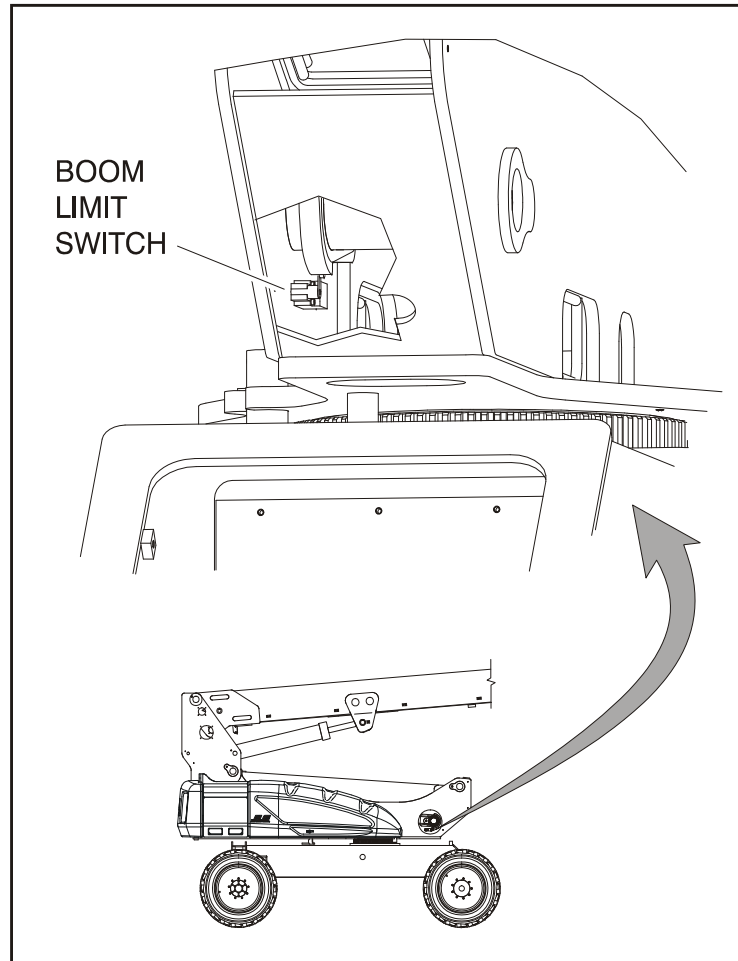

### 10. Cowling and Latches - See Note

11. Hydraulic Pump and Reservoir - Recommended hydraulic fluid level on dipstick (system shut down, boom in stowed position). Breather cap/dipstick secure and working.

### 12. Manual Descent Valve - See Note

13. Control Valve - No unsupported or damaged wires or hoses.

### 14. Generator Start Battery - See Note

15. Engine Oil Supply - Full mark on dipstick; filler cap and filter secure.

### 16. Battery Compartment Right Side - See Note

### 17. Counterweight - See Note

### 18. Limit Switches - Switches operable.

19. Tie Rod Ends and Steering Spindles - Tie rod end stubs locked.

Figure 2-6. Daily Walk-Around Inspection - Sheet 3 of 4



## SECTION 2 - USER RESPONSIBILITIES, MACHINE PREPARATION, AND INSPECTION

20. Oscillating Axle and Lockout Valve (If Equipped) - Check the lockout valve plunger in the depressed position. Swing the turntable until the axle lockout bracket passes the plunger and make sure the plunger is fully extended as shown below

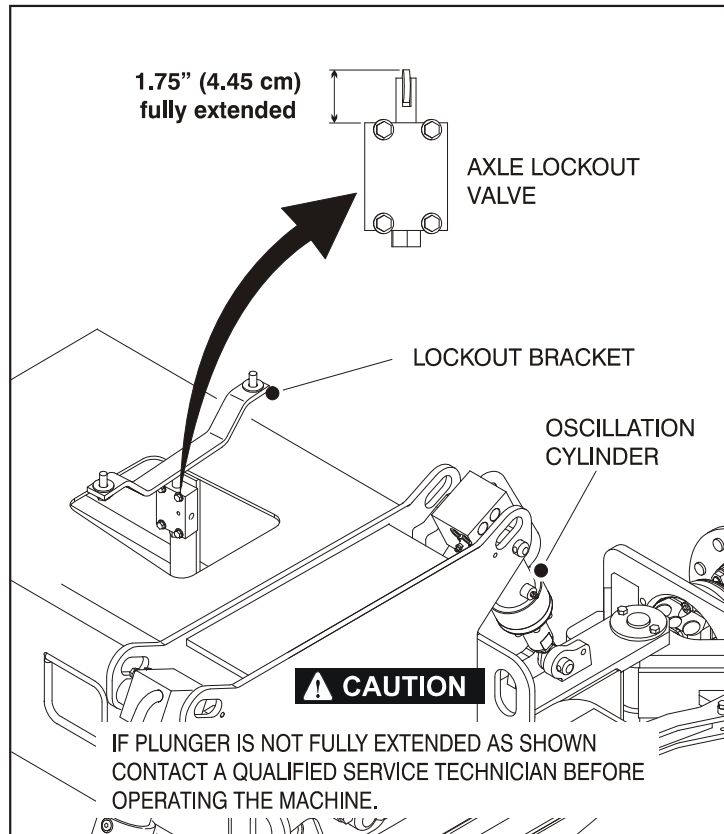

21. Battery Compartment - See Note
22. Fuel Supply - Fuel filler cap secure; Tank - Decals secure and legible.
23. Hydraulic Oil Filter Housing - See Note
24. Battery Charger - See Note
25. Turntable Bearing - Evidence of proper lubrication. No loose bolts or looseness between bearing and structure.
26. Swing Motor - Evidence of proper lubrication.
27. Platform Pivot Pins - See Note
28. Platform Gate - Latch and Hinges in working condition.

Figure 2-7. Daily Walk-Around Inspection - Sheet 4 of 4





## SECTION 3 - MACHINE CONTROLS AND INDICATORS

### SECTION 3. MACHINE CONTROLS AND INDICATORS

#### 3.1 GENERAL

##### **NOTICE**

THE MANUFACTURER HAS NO DIRECT CONTROL OVER MACHINE APPLICATION AND OPERATION. THE USER AND OPERATOR ARE RESPONSIBLE FOR CONFORMING WITH GOOD SAFETY PRACTICES.

This section provides the necessary information needed to understand control functions.

#### 3.2 CONTROLS AND INDICATORS

**NOTE:** The optional generator engine will automatically shut down under the following conditions:

Batteries Fully Charged  
High Oil Temperature  
Low Oil Pressure  
Engine Overspeed  
Overvoltage

**NOTE:** The optional generator engine will not start if the batteries are fully charged or if the Generator Enable switch on the platform console is not in the on position.

#### Ground Control Station

(See Figure 3-1., Ground Control Station w/ Function Enable)

##### **WARNING**

DO NOT OPERATE FROM GROUND CONTROL STATION WITH PERSONNEL IN THE PLATFORM EXCEPT IN AN EMERGENCY.

PERFORM AS MANY PRE-OPERATIONAL CHECK AND INSPECTIONS FROM GROUND CONTROLS AS POSSIBLE.

**NOTE:** When machine is shut down the Platform/Ground Select switch and Emergency Stop must be positioned to OFF.

**NOTE:** If equipped, the Function Enable switch must be held down in order to operate Telescope, Lift, Swing, Jib Lift, Platform Level Override, and Platform Rotate functions.

##### 1. Power/Emergency Stop

A two-position red mushroom shaped switch furnishes power to Platform/Ground Select switch when pulled out (on). When pushed in (off), power is shut off to the Platform/Ground Select switch.

## SECTION 3 - MACHINE CONTROLS AND INDICATORS

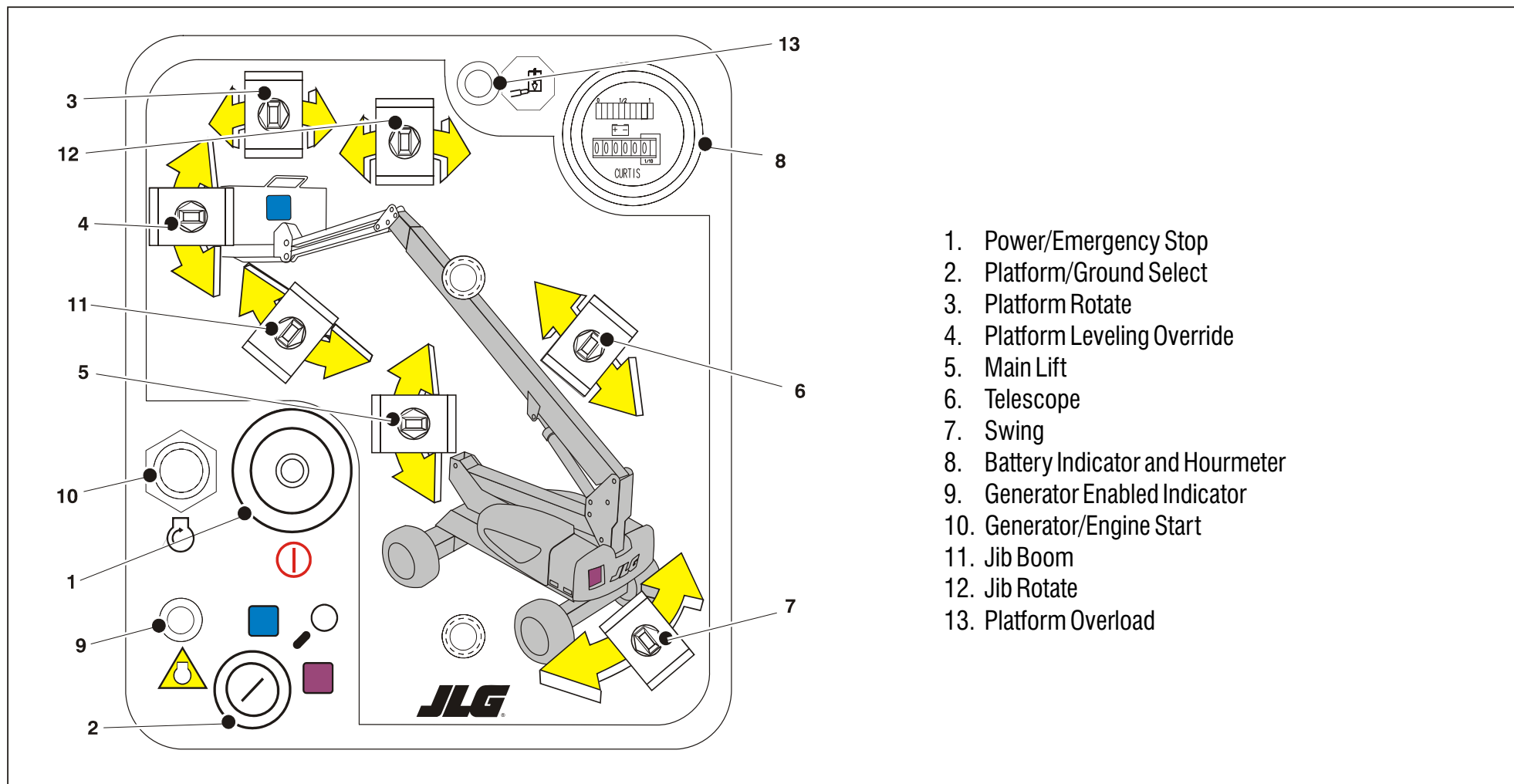

Figure 3-1. Ground Control Station

## SECTION 3 - MACHINE CONTROLS AND INDICATORS

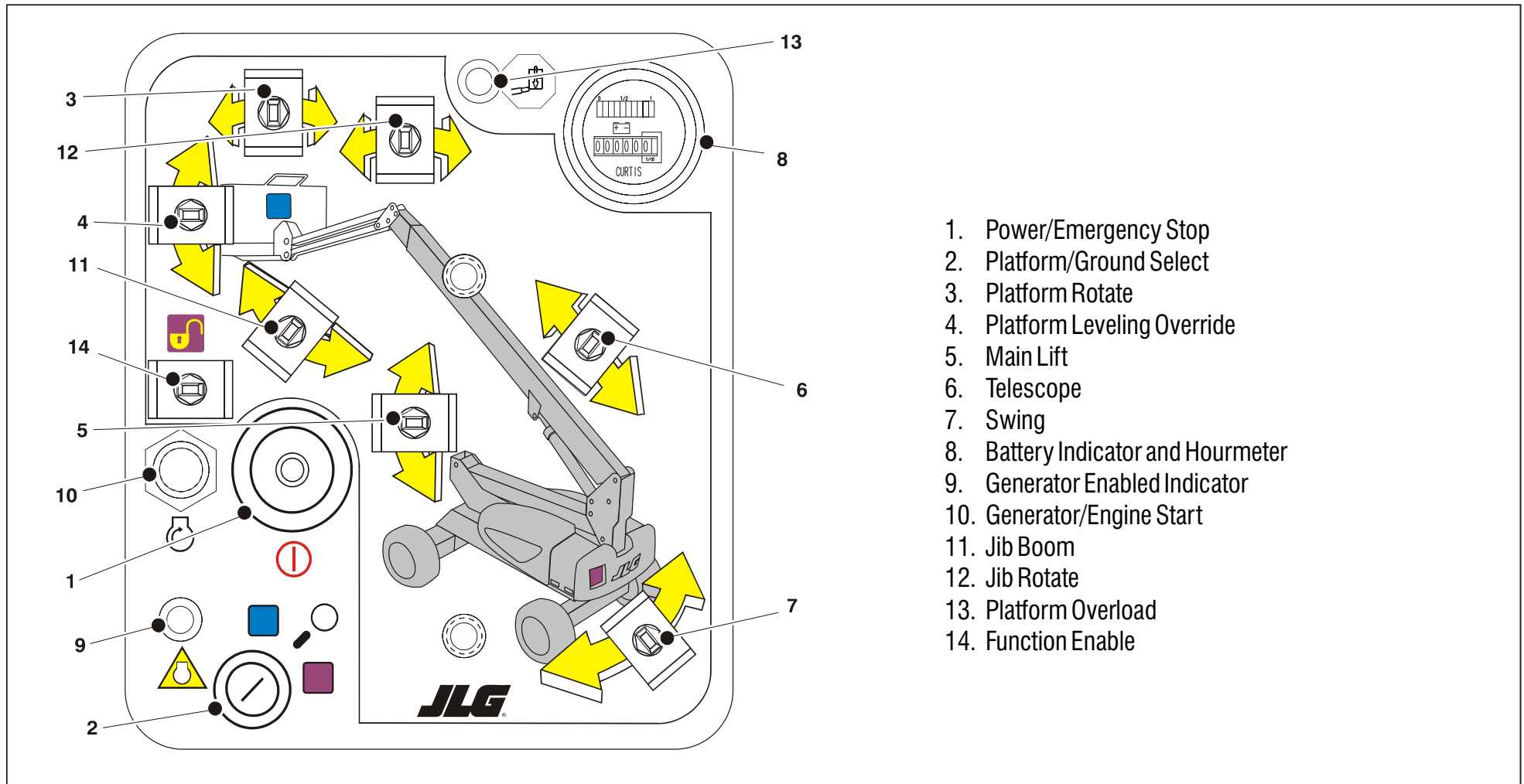

Figure 3-1. Ground Control Station w/ Function Enable



## SECTION 3 - MACHINE CONTROLS AND INDICATORS

### 2. Platform/Ground Select

A three position, key operated switch supplies power to the platform control console when positioned to PLATFORM. With the switch key held in the GROUND position, power is shut off to platform and only ground controls are operable.

**NOTE:** *With PLATFORM/GROUND SELECT switch in the center position, power is shut off to controls at both operating stations.*

### 3. Rotate

A three position switch permits rotation of the platform.

### **⚠ WARNING**

**ONLY USE THE PLATFORM LEVELING OVERRIDE FUNCTION FOR SLIGHT LEVELING OF THE PLATFORM. INCORRECT USE COULD CAUSE THE LOAD/OCCUPANT TO SHIFT OR FALL. FAILURE TO DO SO COULD RESULT IN DEATH OR SERIOUS INJURY.**

### 4. Platform Leveling Override

A three position switch allows the operator to adjust the automatic self leveling system. This switch is used to adjust platform level in situations such as ascending/descending a grade.

### 5. Boom Lift

Provides for raising and lowering of the Boom.

### 6. Telescope

Provides for extension and retraction of the Boom.

### 7. Swing

This switch provides 400 degrees non-continuous turntable rotation. To activate SWING, position switch to LEFT or RIGHT.



## SECTION 3 - MACHINE CONTROLS AND INDICATORS

### 8. Battery Indicator and Hourmeter

An hourmeter is installed in the upper portion of the Ground Control Box. The hourmeter registers up to 9,999.9 hours and cannot be reset.

### 9. Generator Enabled Indicator

The generator enabled indicator lights to signify the generator is enabled and may start at any time as the batteries require. If the indicator flashes, it signifies an abnormal condition for the generator engine (high oil temperature or low oil pressure) or, on all electric machines, an electrical system fault.

**NOTE:** Refer to the Service Manual for the generator fault codes.

### 10. Generator/Engine Start Button (if equipped)

The generator/engine start push-button switch allows the generator to be started manually to top-off the battery charge. The generator will start automatically when the batteries reach a low-charge level.

### 11. Articulating Jib Boom (If Equipped)

This switch provides raising and lowering of the jib.

### 12. Jib Rotate (If Equipped)

A three position switch permits rotation of the jib and platform.

### 13. Platform Overload (If Equipped)

Indicates the platform has been overloaded.

### 14. Function Enable (If Equipped)

If equipped, the enable switch must be held "DOWN" to enable all boom controls when the engine is running.



## SECTION 3 - MACHINE CONTROLS AND INDICATORS

### Platform Control Station

(See Figure 3-1., Platform Control Station)

#### 1. Power/Emergency Stop

A two-position red mushroom shaped switch furnishes power to PLATFORM Controls when pulled out (on). When pushed in (off), power is shut off to the platform functions.

Within about 2 seconds of pulling the switch out, the machine will perform a diagnostic check of the various electrical circuits, and if everything is OK, the platform alarm will beep once. During this time the lights on the indicator panel will also blink once as a bulb check.

#### **WARNING**

**TO AVOID SERIOUS INJURY, DO NOT OPERATE MACHINE IF ANY CONTROL LEVERS OR TOGGLE SWITCHES CONTROLLING PLATFORM MOVEMENT DO NOT RETURN TO THE OFF OR NEUTRAL POSITION WHEN RELEASED.**

#### 2. Generator Enable Control (if equipped)

This switch allows the operator to prevent the generator engine from starting to charge the batteries when using the machine indoors.

#### 3. Lights (If Equipped)

This switch operates accessory light packages if the machine is so equipped.

#### 4. Drive/Steer

The DRIVE joystick provides for driving either forward or backward. The controller is 'ramped' to allow variable drive speed.

Steering is controlled by a thumb operated switch on top of the joystick.



## SECTION 3 - MACHINE CONTROLS AND INDICATORS

---

### 5. Telescope Control

This switch allows extension and retraction of the main boom.

### 6. Articulating Jib (If Equipped)

This switch controls the raising and lowering of the jib (up or down).

### 7. Jib Rotate (If Equipped)

A three position switch permits rotation of the jib and platform (left or right).

### 8. Platform Rotate

This switch controls the rotation of the basket (left or right).

### 9. Function Speed Control

Controls the speed of Boom and Swing Functions. Rotate CCW for slower speed and CW for faster speed. To adjust to creep, turn knob fully CCW until it clicks.

### 10. Main Lift/Swing

The dual axis joystick is provided for main lift and swing. Push forward to lift up, pull backward to lower. Move right to swing right, move left to swing left. Proportional control of these functions can be attained by using the Function Speed control.

**NOTE:** *Main lift and swing functions may be selected at the same time. Maximum speed is reduced when both functions are selected.*



## SECTION 3 - MACHINE CONTROLS AND INDICATORS

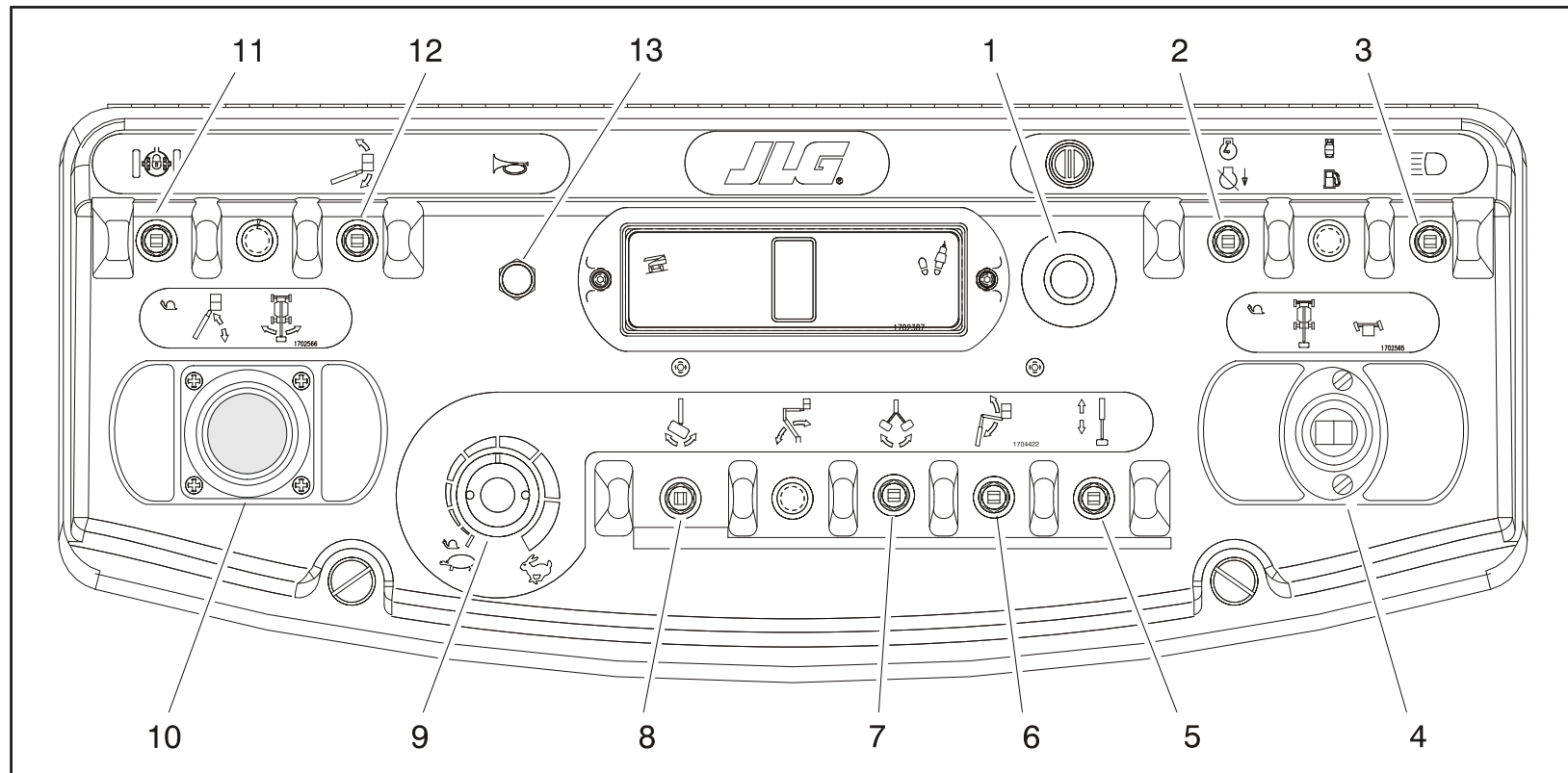

- |                         |                          |                     |                                |
|-------------------------|--------------------------|---------------------|--------------------------------|
| 1. Power/Emergency Stop | 5. Telescope             | 8. Platform Rotate  | 11. Posi Track                 |
| 2. Generator Enable     | 6. Articulating Jib Boom | 9. Function Speed   | 12. Platform Leveling Override |
| 3. Lights               | 7. Jib Rotate            | 10. Main Lift/Swing | 13. Horn                       |
| 4. Drive/Steer          |                          |                     |                                |

**Figure 3-1. Platform Control Station**





## SECTION 3 - MACHINE CONTROLS AND INDICATORS

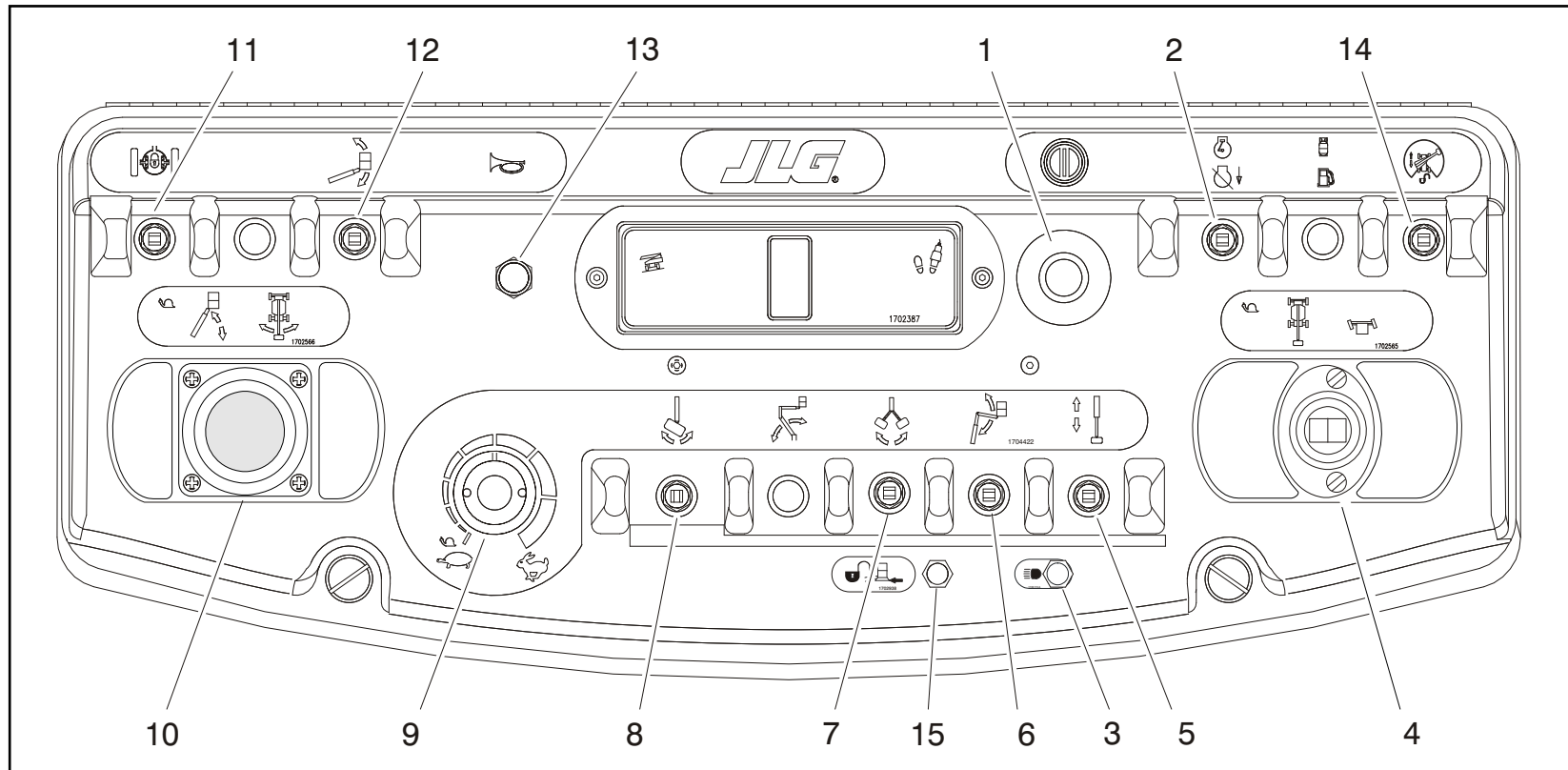

- |                         |                          |                                |                                |
|-------------------------|--------------------------|--------------------------------|--------------------------------|
| 1. Power/Emergency Stop | 5. Telescope             | 9. Function Speed              | 13. Horn                       |
| 2. Generator Enable     | 6. Articulating Jib Boom | 10. Main Lift/Swing            | 14. Drive Orientation Override |
| 3. Lights               | 7. Jib Rotate            | 11. Posi Track                 | 15. Soft Touch Override        |
| 4. Drive/Steer          | 8. Platform Rotate       | 12. Platform Leveling Override |                                |

**Figure 3-2. Platform Control Station - w/Drive Orientation**



## SECTION 3 - MACHINE CONTROLS AND INDICATORS

---

### 11. Posi-Track Control

Activating the Posi-Track switch distributes available power evenly between the two drive wheels for improved traction. The control system may also engage the posi-track function automatically when more traction is required.

**NOTE:** *The optional 4 Wheel Assist will also engage with the Posi-Track Control.*

### **WARNING**

**ONLY USE THE PLATFORM LEVELING OVERRIDE FUNCTION FOR SLIGHT LEVELING OF THE PLATFORM. INCORRECT USE COULD CAUSE THE LOAD/OCCUPANT TO SHIFT OR FALL. FAILURE TO DO SO COULD RESULT IN DEATH OR SERIOUS INJURY.**

### 12. Platform Leveling Override

A three position switch allows the operator to adjust the automatic self leveling system. This switch is used to adjust platform level in situations such as ascending/descending a grade.

### 13. Horn

If pressed, this switch supplies power to the horn.

### 14. Drive Orientation Override

When the boom is swung over the rear tires or further in either direction, the Drive Orientation indicator will illuminate when the drive function is selected. Push and release the switch, and within 3 seconds move the Drive/Steer control to activate drive or steer. Before driving, locate the black/white orientation arrows on both the chassis and the platform controls and match the control direction arrow to the intended chassis direction.

### 15. Soft Touch Override Switch (If equipped)

This switch enables the functions that were cut out by the Soft Touch system to operate again at creep speed, allowing the operator to move the platform away from the obstacle that caused the shutdown situation.



## SECTION 3 - MACHINE CONTROLS AND INDICATORS

### Platform Control Indicator Panel

(See Figure 3-3., Platform Control Indicator Panel)

**NOTE:** The platform control indicator panel uses different shaped symbols to alert the operator to different types of operational situations that could arise. The meaning of those symbols are explained below.

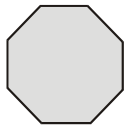

Indicates a potentially hazardous situation, which if not corrected, could result in serious injury or death. This indicator will be red.



Indicates an abnormal operating condition, which if not corrected, may result in machine interruption or damage. This indicator will be yellow.



Indicates important information regarding the operating condition, i.e. procedures essential for safe operation. This indicator will be green with the exception of the capacity indicator which will be green or yellow depending upon platform position.

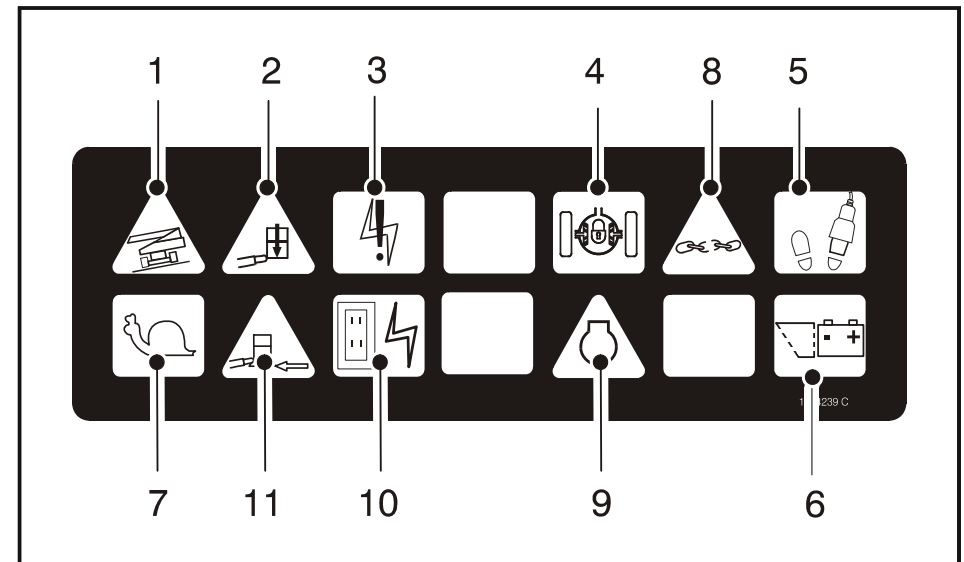

- |                       |                                |
|-----------------------|--------------------------------|
| 1. Tilt Alarm Warning | 5. Footswitch/Enable Indicator |
| 2. Overload indicator | 6. Low Battery Indicator       |
| 3. System Distress    | 7. Creep Indicator             |
| 4. Posi Track         | 8-11. Not Used                 |

**Figure 3-3. Platform Control Indicator Panel**



## SECTION 3 - MACHINE CONTROLS AND INDICATORS

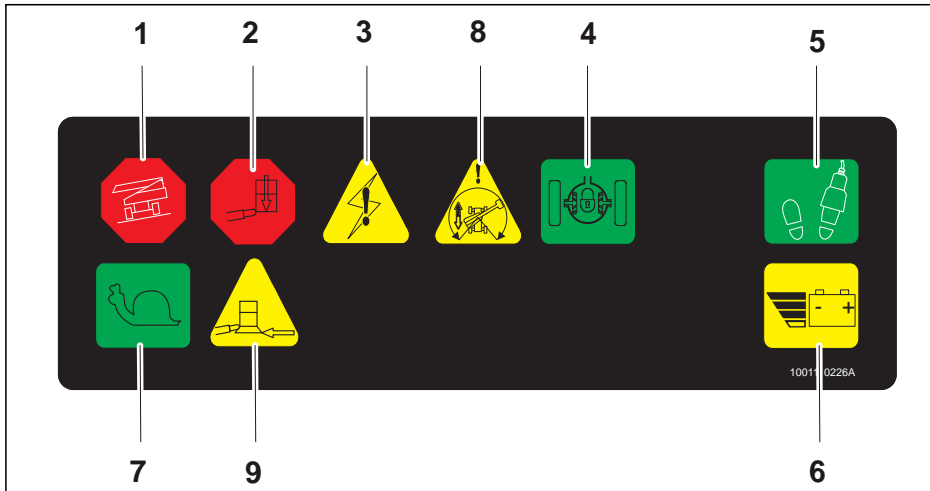

- |                      |                               |
|----------------------|-------------------------------|
| 1. Tilt              | 6. Low Battery                |
| 2. Platform Overload | 7. Creep                      |
| 3. System Distress   | 8. Drive Orientation Override |
| 4. Posi-Track        | 9. Soft Touch Indicator       |
| 5. Enable            |                               |

**Figure 3-4. Platform Control Indicator Panel w/ Drive Orientation**

### 1. Tilt Alarm Warning Light and Alarm

This orange illuminator indicates that the chassis is on a slope. An alarm will also sound when the chassis is on a slope and the boom is above horizontal. If lit when boom is raised or extended, retract and lower to below horizontal then reposition machine so that it is level before continuing operation. If the boom is above horizontal and the machine is on a slope, the tilt alarm warning light will illuminate and an alarm will sound and CREEP is automatically activated.

### **! WARNING**

**IF TILT WARNING LIGHT IS ILLUMINATED WHEN BOOM IS RAISED OR EXTENDED, RETRACT AND LOWER TO BELOW HORIZONTAL THEN REPOSITION MACHINE SO THAT IT IS LEVEL BEFORE EXTENDING BOOM OR RAISING BOOM ABOVE HORIZONTAL.**

### 2. Platform Overload (If Equipped)

Indicates the platform has been overloaded.



## SECTION 3 - MACHINE CONTROLS AND INDICATORS

### 3. System Distress Light

The system distress light indicates an abnormal condition for machine control system.

The three likely causes of a system fault are:

- a. The seven second enable time has been allowed to lapse or a function was selected before pushing down the footswitch.
- b. The maximum power limit has been reached and the machine is not moving. This condition is the same as stalling the engine by asking it to provide more power than it was designed to do.
- c. There is some other fault in one of the circuits. Refer to the service manual.

### 4. Posi-Track Indicator

This indicator lights when posi-traction is operating.

### 5. Footswitch/Enable Indicator

To operate any function, the footswitch must be depressed and the function selected within seven seconds. The enable indicator shows that the controls are enabled. If a function is not selected within seven seconds, or if a seven second lapse between ending one

function and beginning the next function, the enable light will go out and the footswitch must be released and depressed again to enable the controls.

Releasing the footswitch removes power from all controls and applies the drive brakes.

#### **⚠ WARNING**

**TO AVOID SERIOUS INJURY, DO NOT REMOVE, MODIFY OR DISABLE THE FOOTSWITCH BY BLOCKING OR ANY OTHER MEANS.**

#### **⚠ WARNING**

**FOOTSWITCH MUST BE ADJUSTED IF FUNCTIONS ACTIVATE WHEN SWITCH ONLY OPERATES WITHIN LAST 1/4" OF TRAVEL, TOP OR BOTTOM.**

### 6. Low Battery Light

This light indicates when battery voltage is below 45 volts and flashes below 40 volts. The machine will shut down below 33 volts.

### 7. Creep Speed Indicator

When the Function Speed Control is turned to the creep position, the indicator acts as a reminder that all functions are set to the slowest speed.



## SECTION 3 - MACHINE CONTROLS AND INDICATORS

---

### 8. Drive Orientation Indicator

When the boom is swung beyond the rear drive tires or further in either direction, the Drive Orientation indicator will illuminate when the drive function is selected. This is a signal for the operator to activate the Drive Orientation Override Switch and verify the drive control direction is correct.

### 9. Soft Touch Indicator (If Equipped)

When illuminated (Yellow) the Soft Touch bumper is against an object. All controls are disabled until the override button is pushed, at which time controls are active in the Creep mode.



## SECTION 4 - MACHINE OPERATION

### SECTION 4. MACHINE OPERATION

#### 4.1 DESCRIPTION

This machine is a self-propelled hydraulic lift equipped with a work platform on the end of an elevating, articulating and rotating boom.

The primary operator control station is in the platform. From this control station, the operator can drive and steer the machine in both forward and reverse directions. The operator can raise or lower the upper or lower boom or swing the boom to the left or right. Standard boom swing is 400 degree non-continuous left and right of the stowed position. The machine has a Ground Control Station which will override the Platform Control Station. Ground Controls operate Boom Lift and Swing, and are to be used in an emergency to lower the platform to the ground should the operator in the platform be unable to do so. The Ground Control is also to be used in Pre-Start Inspection.

#### 4.2 OPERATING CHARACTERISTICS AND LIMITATIONS

##### Capacities

The boom can be raised above horizontal with or without any load in platform, if:

1. Machine is positioned on a smooth, firm and level surface.
2. Load is within manufacturer's rated capacity.
3. All machine systems are functioning properly.
4. Proper tire pressure.
5. Machine is as originally equipped from JLG.

##### Stability

Machine stability is based on two (2) conditions which are called FORWARD and BACKWARD stability. The machine's position of least FORWARD stability is shown in (See Figure 4-1.), and its position of least BACKWARD stability is shown in (See Figure 4-2.)



## SECTION 4 - MACHINE OPERATION

---

### **⚠ WARNING**

**TO AVOID FORWARD OR BACKWARD TIPPING, DO NOT OVERLOAD MACHINE OR OPERATE THE MACHINE ON AN OUT-OF-LEVEL SURFACE.**

## 4.3 MOTOR OPERATION

### Power/Emergency Stop

This red, mushroom-shaped switch provides battery power, when pulled out (on), for all machine functions. The switch should be pushed in (off) when recharging the batteries or parking the machine overnight.

Within about 2 seconds of pulling the switch out, the machine will perform a diagnostic check of the various electrical circuits, and if everything is OK, the platform alarm will beep once. During this time the lights on the indicator panel will also blink once as a bulb check.

### Platform/Ground Select Switch

The Platform/Ground Select switch directs power to the Ground or Platform controls as selected. For power, the POWER/EMERGENCY STOP switch must also be pulled out (on).





## SECTION 4 - MACHINE OPERATION

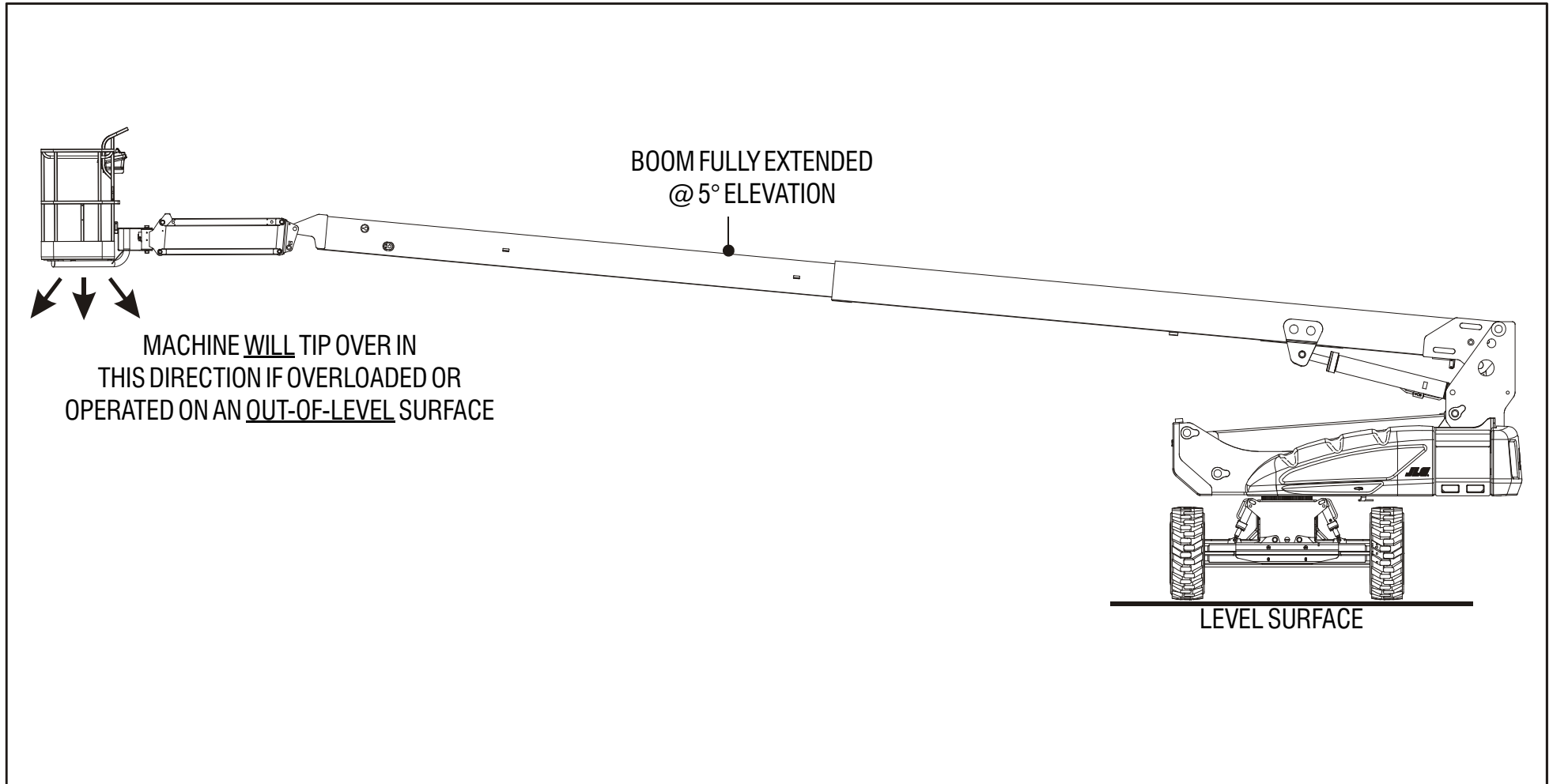

Figure 4-1. Position of Least Forward Stability



## SECTION 4 - MACHINE OPERATION

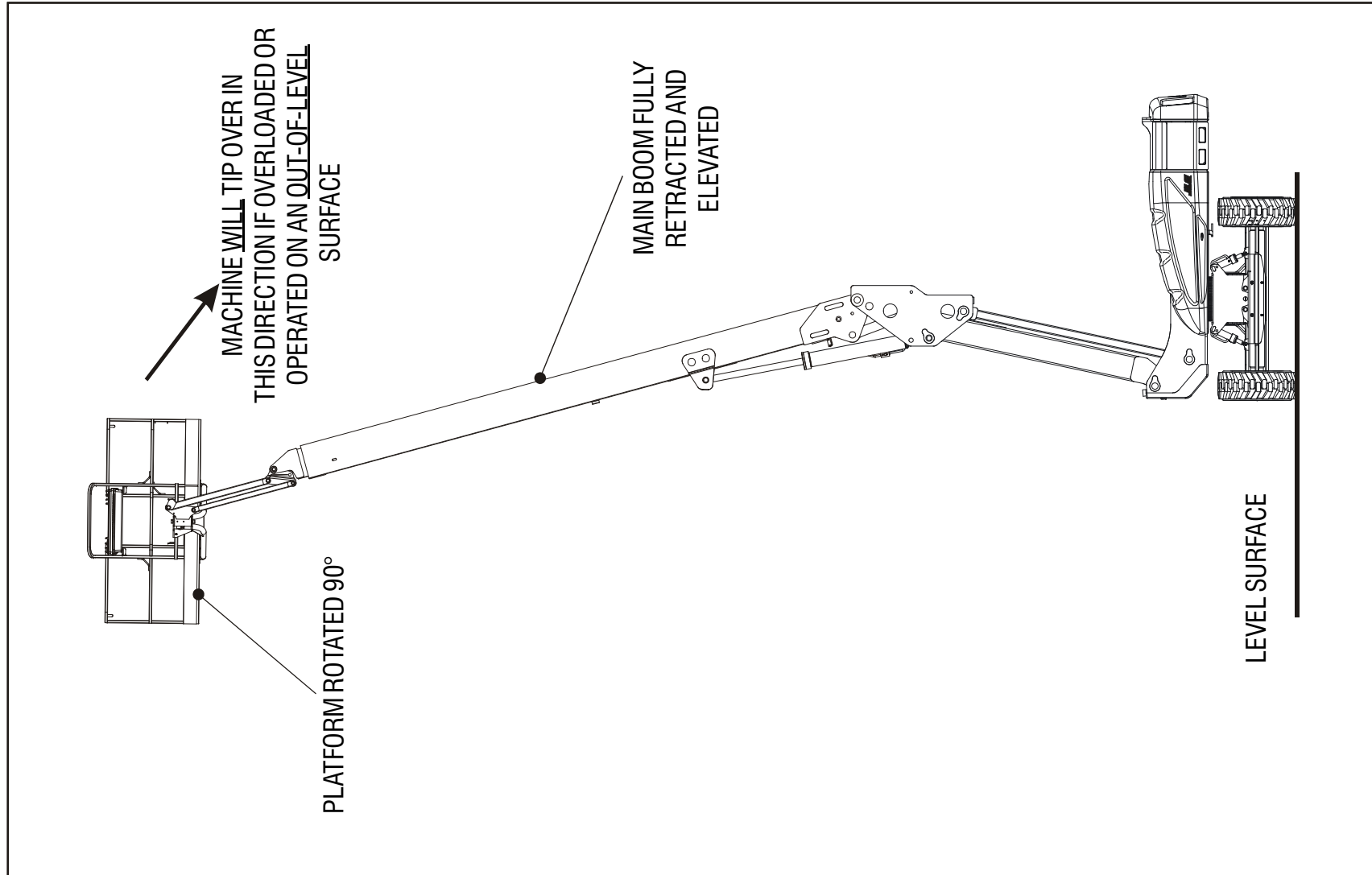

Figure 4-2. Position of Least Backward Stability



## SECTION 4 - MACHINE OPERATION

### 4.4 TRAVELING (DRIVING)

**NOTE:** When the upper boom is raised approximately 11 degrees above horizontal, the high drive function will automatically be in low drive.

#### **NOTICE**

**IF THE MACHINE IS OPERATED AT A VERY SLOW SPEED OR STALLED WHEN CLIMBING A GRADE OF 20% OR GREATER, DRIVE FUNCTION WILL STOP. REMOVE YOUR FOOT FROM FOOT-SWITCH, AND PUSH THE FOOTSWITCH DOWN AGAIN TO RESET IT.**

#### **⚠ WARNING**

**DO NOT DRIVE WITH BOOM ABOVE HORIZONTAL EXCEPT ON A SMOOTH, FIRM AND LEVEL SURFACE.**

**TO AVOID LOSS OF TRAVEL CONTROL OR “TIP OVER” , DO NOT DRIVE MACHINE ON GRADES EXCEEDING THOSE SPECIFIED ON THE SERIAL NUMBER PLATE.**

**DO NOT DRIVE ON SIDESLOPES WHICH EXCEED 5 DEGREES.**

**USE EXTREME CAUTION WHEN DRIVING IN REVERSE AND AT ALL TIMES WHEN THE PLATFORM IS ELEVATED.**

**BEFORE DRIVING, MAKE SURE BOOM IS POSITIONED OVER REAR**

**DRIVE AXLE. IF BOOM IS OVER FRONT WHEELS, STEER AND DRIVE CONTROLS WILL BE REVERSED.**

### Traveling Forward and Reverse

1. At Platform Controls, pull out Emergency Stop switch and activate footswitch.
2. Position Drive controller to FORWARD or REVERSE as desired.

This machine is equipped with a Drive Orientation Indicator. The yellow light on the platform control console indicates that the boom is swung beyond the rear drive tires and the machine may Drive/Steer in the opposite direction from the movement of the controls. If the indicator is illuminated, operate the Drive function in the following manner:

1. Match the black and white direction arrows on both platform control panel and the chassis to determine the direction the machine will travel.
2. Push and release the Drive Orientation Override switch. Within 3 seconds, slowly move the Drive control toward the arrow matching the intended direction of machine travel. The indicator light will flash during the 3 second interval until the drive function is selected.

## SECTION 4 - MACHINE OPERATION

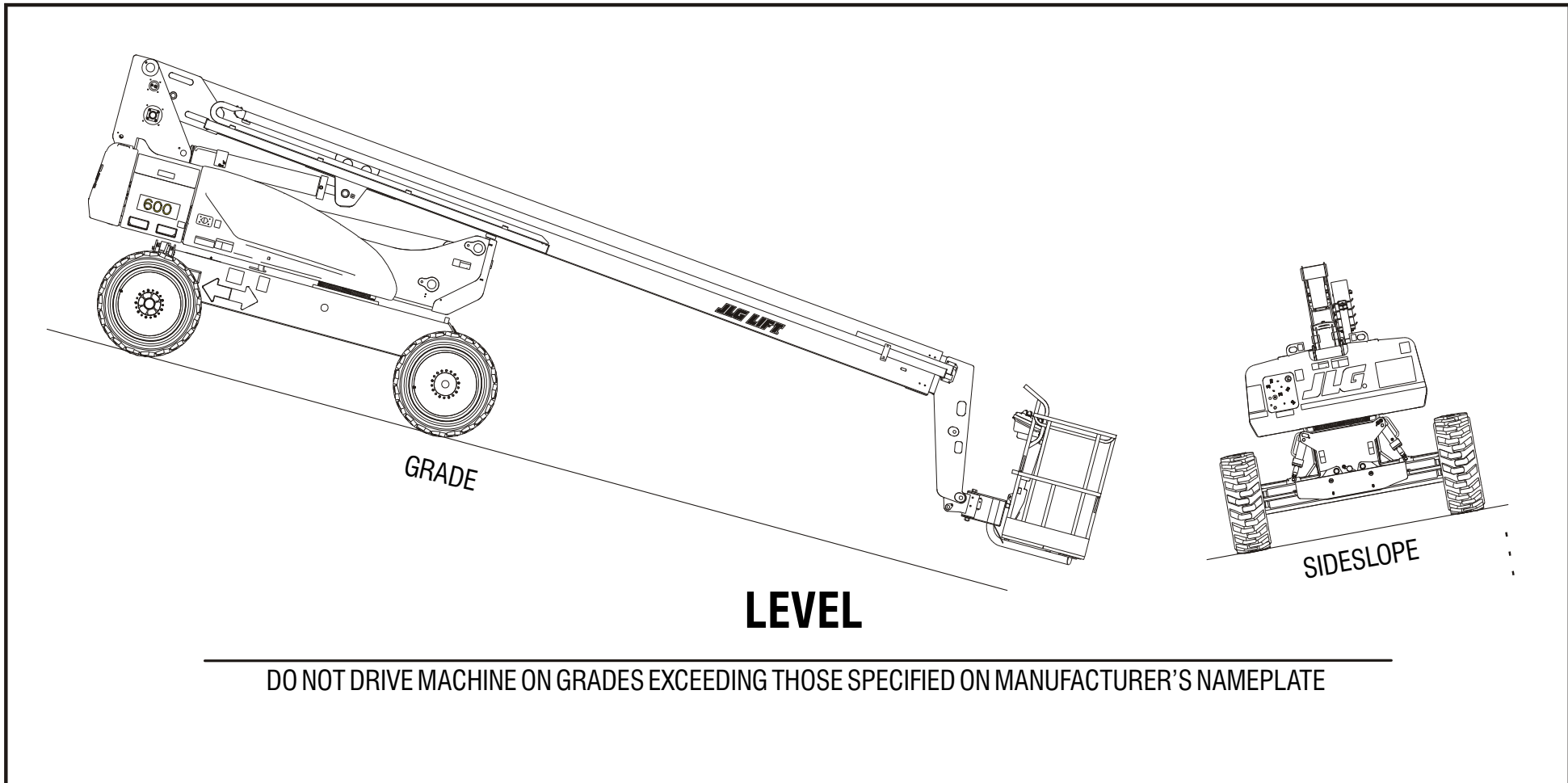

Figure 4-3. Grade and Side Slopes



## SECTION 4 - MACHINE OPERATION

### 4.5 STEERING

Position thumb switch on Drive/Steer controller to RIGHT for steering right, or to LEFT for steering left.

### 4.6 PLATFORM

#### Platform Level Adjustment

To Level Up or Down - Position the Platform/Level control switch Up or Down and hold until the platform is level.

#### **⚠ WARNING**

**ONLY USE THE PLATFORM LEVELING OVERRIDE FUNCTION FOR SLIGHT LEVELING OF THE PLATFORM. INCORRECT USE COULD CAUSE THE LOAD/OCCUPANT TO SHIFT OR FALL. FAILURE TO DO SO COULD RESULT IN DEATH OR SERIOUS INJURY.**

#### Platform Rotation

To rotate the platform to the left or right, use the Platform Rotate control switch to select the direction and hold until desired position is reached.

### 4.7 BOOM

#### **⚠ WARNING**

**DO NOT SWING OR RAISE BOOM ABOVE HORIZONTAL WHEN MACHINE IS OUT OF LEVEL.**

**DO NOT DEPEND ON TILT ALARM AS A LEVEL INDICATOR FOR THE CHASSIS.**

**TO AVOID TIP OVER, LOWER PLATFORM TO GROUND LEVEL. THEN DRIVE MACHINE TO A LEVEL SURFACE BEFORE RAISING BOOM.**

**TO AVOID SERIOUS INJURY, DO NOT OPERATE MACHINE IF ANY CONTROL LEVER OR TOGGLE SWITCH CONTROLLING PLATFORM MOVEMENT DOES NOT RETURN TO THE 'OFF' OR NEUTRAL POSITION WHEN RELEASED.**

**IF THE PLATFORM DOES NOT STOP WHEN A CONTROL SWITCH OR LEVER IS RELEASED, REMOVE FOOT FROM FOOTSWITCH OR USE EMERGENCY STOP SWITCH TO STOP THE MACHINE.**



## SECTION 4 - MACHINE OPERATION

---

### Swinging the Boom

To swing boom, use SWING control switch to select RIGHT or LEFT direction.

#### **NOTICE**

**WHEN SWINGING THE BOOM MAKE SURE THERE IS AMPLE ROOM FOR THE BOOM TO CLEAR SURROUNDING WALLS, PARTITIONS AND EQUIPMENT.**

### Raising and Lowering the Upper Boom

To raise or lower the Upper Boom, use Upper Boom Lift switch to select UP or DOWN movement.

## 4.8 GENERATOR (OPTIONAL)

### Automatic Operating Mode

The generator will operate in automatic mode when:

1. Ground Control EMS is pulled out (on), **and**:
2. The Generator Enable switch on the platform control console is in the On or Enable position.

When the above conditions apply, the generator's controller will monitor status of the batteries, will turn on automatically when the battery voltage drops as a result of discharge and will turn off when batteries are fully charged.

### Battery Only Operating Mode

The machine will operate in the battery only mode when:

1. Ground Control EMS is pulled out, **and**:
2. The switch on the platform control console is in the Off or Disable position.

The batteries can be used until they are fully discharged.

### Manual (Charge) Operating Mode

The generator will operate in manual mode when:

1. Ground Control EMS is pulled out, **and**:
2. The switch on the platform control console is in the On or Enable position **and**:
3. The Manual Charge push button is activated.

Activation of the Manual Charge button will start the engine and begin the charging cycle even if the batteries are charged above the level of automatic start.



## SECTION 4 - MACHINE OPERATION

### 4.9 FUNCTION SPEED CONTROL

This control affects the speed of all boom functions and Platform Rotate. When in the CCW maximum position, Drive is placed in creep speed.

### 4.10 OSCILLATING AXLE LOCKOUT TEST (IF EQUIPPED)

#### **NOTICE**

**LOCKOUT SYSTEM TEST MUST BE PERFORMED QUARTERLY, ANY TIME A SYSTEM COMPONENT IS REPLACED, OR WHEN IMPROPER SYSTEM OPERATION IS SUSPECTED.**

Refer to Section 6.4, Oscillating Axle Lockout Test (If Equipped) for procedure.

### 4.11 SHUT DOWN AND PARK

**NOTE:** *When parking overnight, batteries should be charged properly to ensure readiness for following workday.*

**NOTE:** *Electric machines are equipped with a static strap due to static electricity build-ups. Strap is located under rear of machine chassis.*

To shut down and park the machine, the procedures are as follows:

1. Drive machine to a reasonably well protected area.
2. Ensure boom is lowered over rear drive axle.
3. Push in the Emergency Stop at Platform Controls.
4. Push in the Emergency Stop at Ground Controls. Position Platform/Ground Select switch to center OFF.
5. If necessary, cover Platform Controls to protect instruction placards, warning decals and operating controls from hostile environment.



## SECTION 4 - MACHINE OPERATION

---

### 4.12 LIFTING AND TIE DOWN

#### Lifting

1. Refer to the Machine Serial Number Plate, call JLG Industries, or weigh the individual unit to find out the Gross Vehicle Weight.
2. Place the boom in the stowed position.
3. Remove all loose items from the machine.
4. Properly adjust the rigging to prevent damage to the machine and so the machine remains level.

#### Tie Down

**NOTICE**

**WHEN TRANSPORTING THE MACHINE, THE BOOM MUST BE FULLY LOWERED INTO THE BOOM REST.**

1. Place the boom in the stowed position.
2. Remove all loose items from the machine.
3. Secure the chassis and the platform using straps or chains of adequate strength.





## SECTION 4 - MACHINE OPERATION

# IMPORTANT

<b>LIFTING INSTRUCTIONS</b>	<b>TIE DOWN INSTRUCTIONS</b>
<ol style="list-style-type: none"> <li>1. See the Operators and Safety Manual for approximate gross weight of machine as originally manufactured.</li> <li>2. Place boom in the stowed position with turntable locked.</li> <li>3. Remove all loose items from machine.</li> <li>4. Properly adjust rigging to prevent damage to machine and so machine remains level.</li> </ol>	<ol style="list-style-type: none"> <li>1. Place boom in the stowed position with turntable locked.</li> <li>2. Remove all loose items from machine.</li> <li>3. Secure the chassis and the platform using straps or chains of adequate strength.</li> </ol> <p><b>Refer to the Operators and Safety Manual for more information.</b></p>

Figure 4-4. Lifting and Tie Down Chart



## SECTION 4 - MACHINE OPERATION

### 4.13 TOWING INSTRUCTIONS

#### **⚠ WARNING**

THE MACHINE HAS NO TOWING BRAKES. THE TOWING VEHICLE MUST BE ABLE TO CONTROL THE MACHINE AT ALL TIMES. TOWING IS NOT PERMITTED ON HIGHWAY.

#### **⚠ WARNING**

KEEP ALL BODY PARTS AWAY FROM MOVING COMPONENTS.

FAILURE TO FOLLOW THESE INSTRUCTIONS COULD RESULT IN DEATH OR SERIOUS INJURY.

#### **⚠ CAUTION**

MAXIMUM TOWING SPEED: 5 MPH (8 KPH) FOR A DISTANCE OF 5 MILES (8K).

MAXIMUM TOWING GRADE: 25%

The following instructions are for towing using the optional tow bar.

1. Lock the turntable in the travel position, with the boom fully lowered and retracted.

2. Lower the tow bar to the towing position and connect to the towing vehicle.
3. Disengage the drive hubs.
4. Position the steer/tow selector to the towing (out) position.

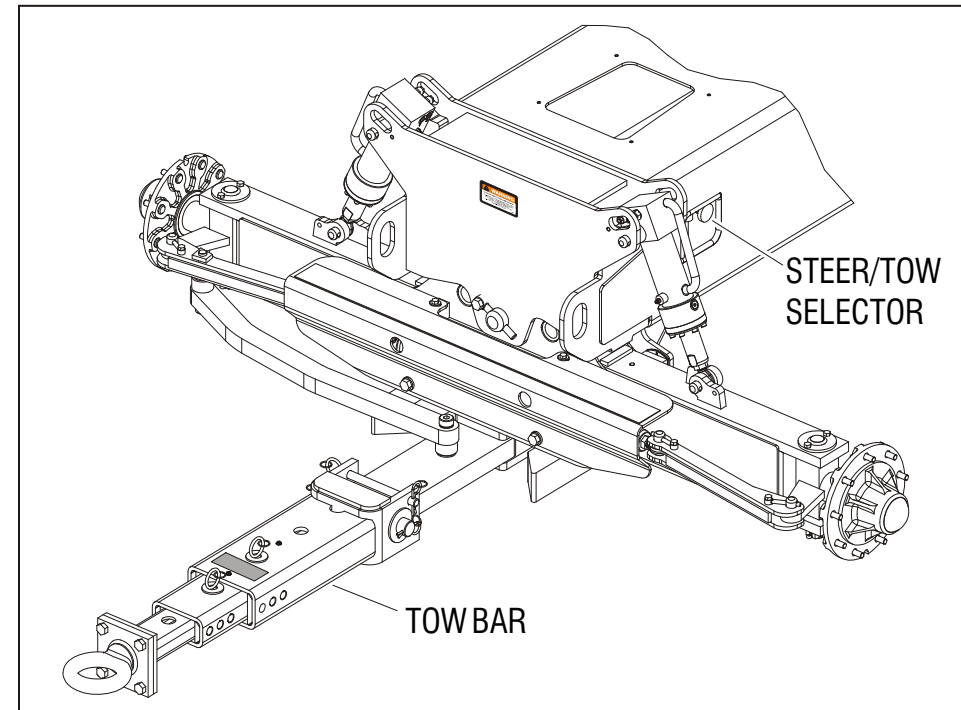

5. To return the machine to the self-propelled mode, follow the above steps in the reverse order.

## SECTION 4 - MACHINE OPERATION

### 4.14 DRIVE HUB

#### Disengaging for Towing

**⚠ CAUTION**

MAKE SURE THE DISCONNECT MECHANISM IS ONLY OPERATED WITH THE MACHINE AT A STANDSTILL.

1. Remove the two hex head bolts from the cover.

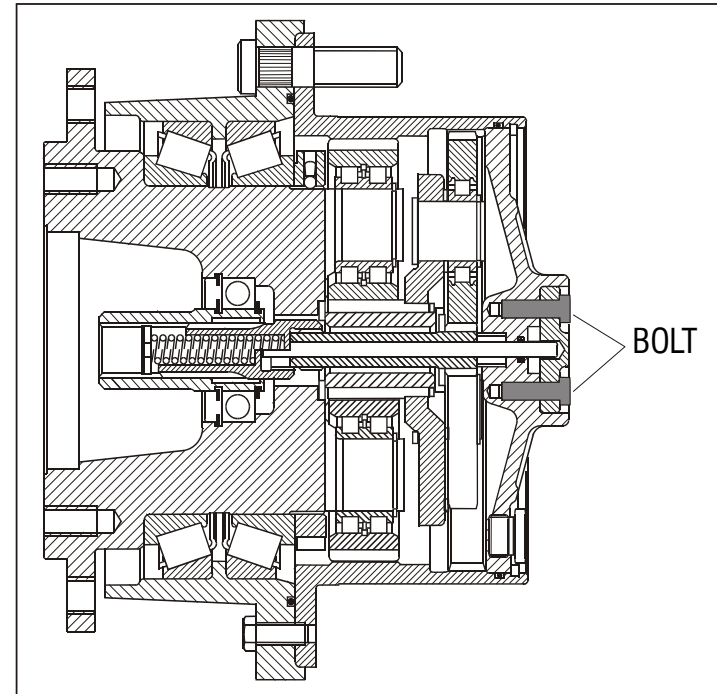

2. Remove the cover.

## SECTION 4 - MACHINE OPERATION

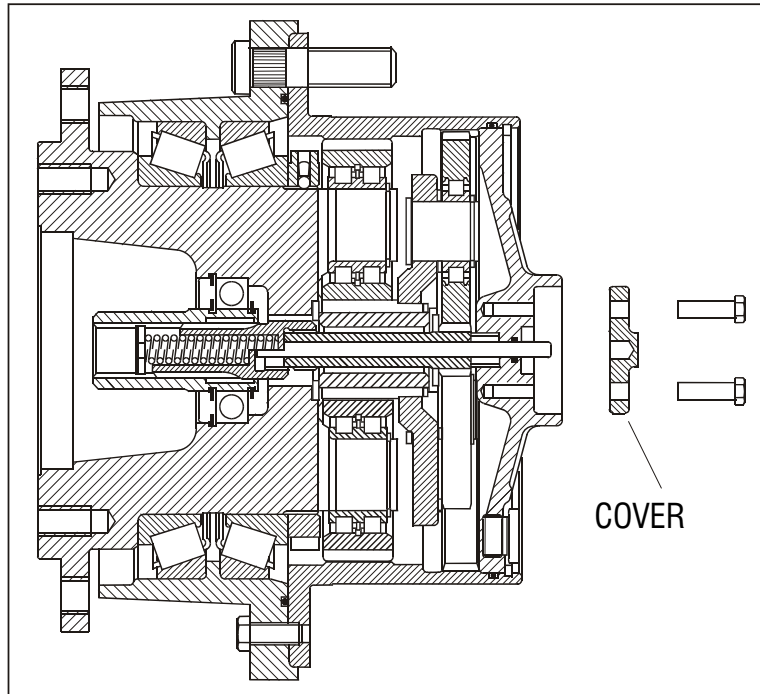

3. Rotate the cover to show the inside diameter

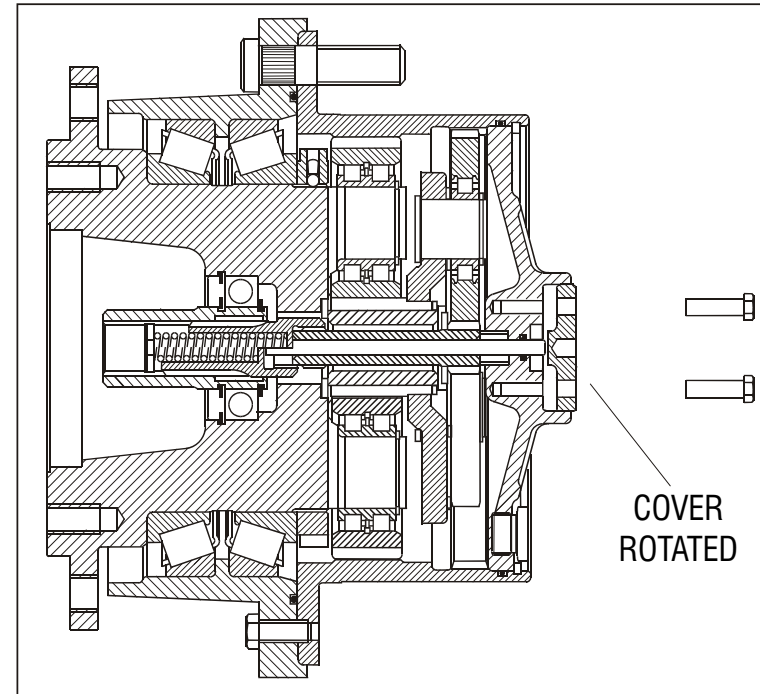

4. Install the bolts and torque 6.3 ft. lbs. (8.8 Nm) until they are flush with the cover.

5. The machine is ready to be towed.

### **WARNING**

**BEFORE THE MACHINE IS SEPARATED FROM THE TOWING VEHICLE, EITHER THE DRIVE HUB HAS TO BE REENGAGED OR PROPER STEPS MUST BE TAKEN TO PREVENT THE MACHINE FROM MOVING.**



## SECTION 4 - MACHINE OPERATION

---

### Engaging after Towing is Complete

**⚠ WARNING**

**THE COVER IS UNDER SPRING FORCE**

1. Remove the 2 hex head bolts securing the cover evenly and remove the cover.
2. Rotate the cover 180 degrees and secure with the two hex head bolts.
3. Torque the hex head bolts 6.3 ft.lbs. (8.8 Nm).
4. The gear drive should now be reengaged and the machine can be disconnected from the towing vehicle.



## SECTION 4 - MACHINE OPERATION

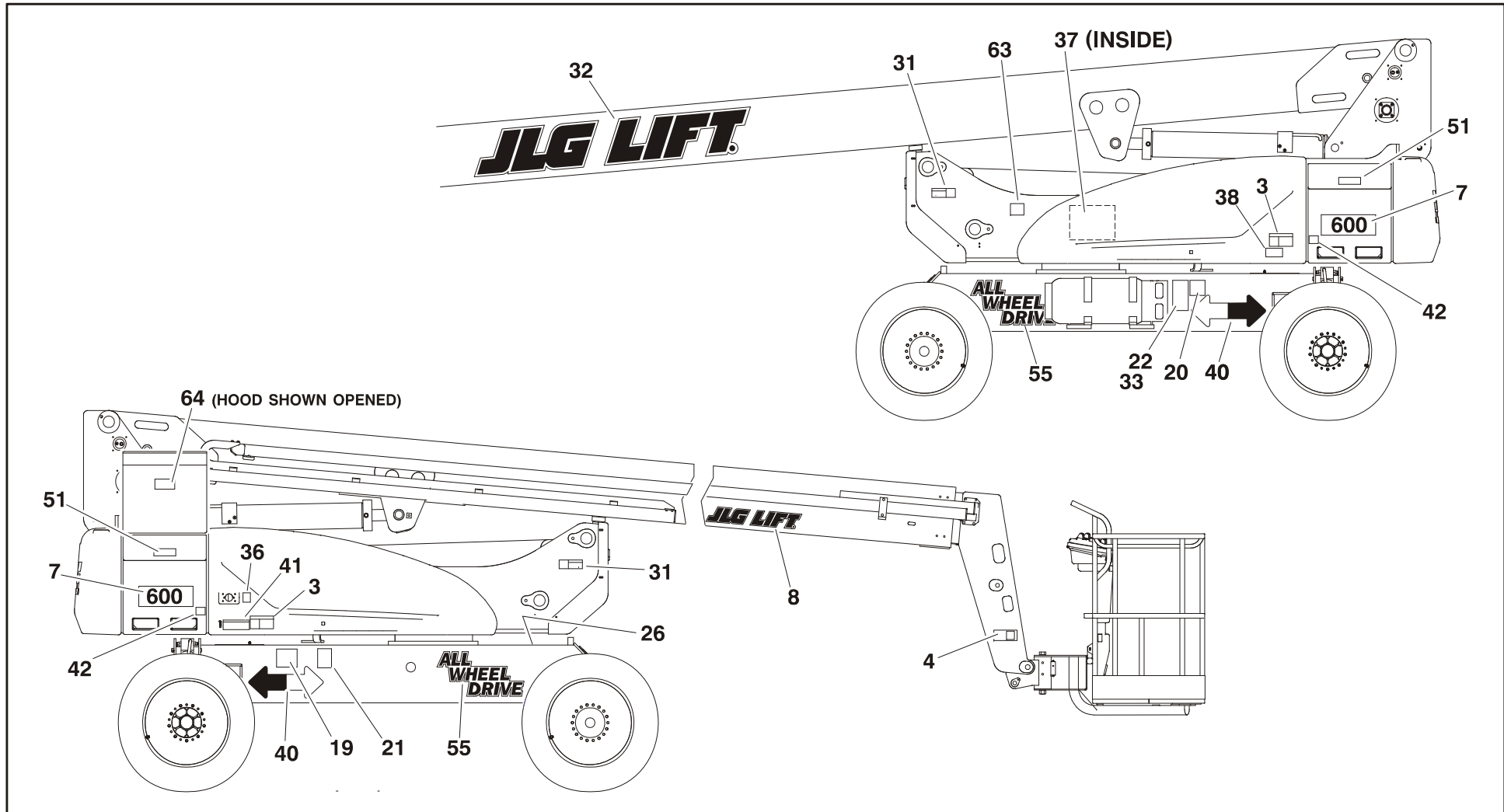
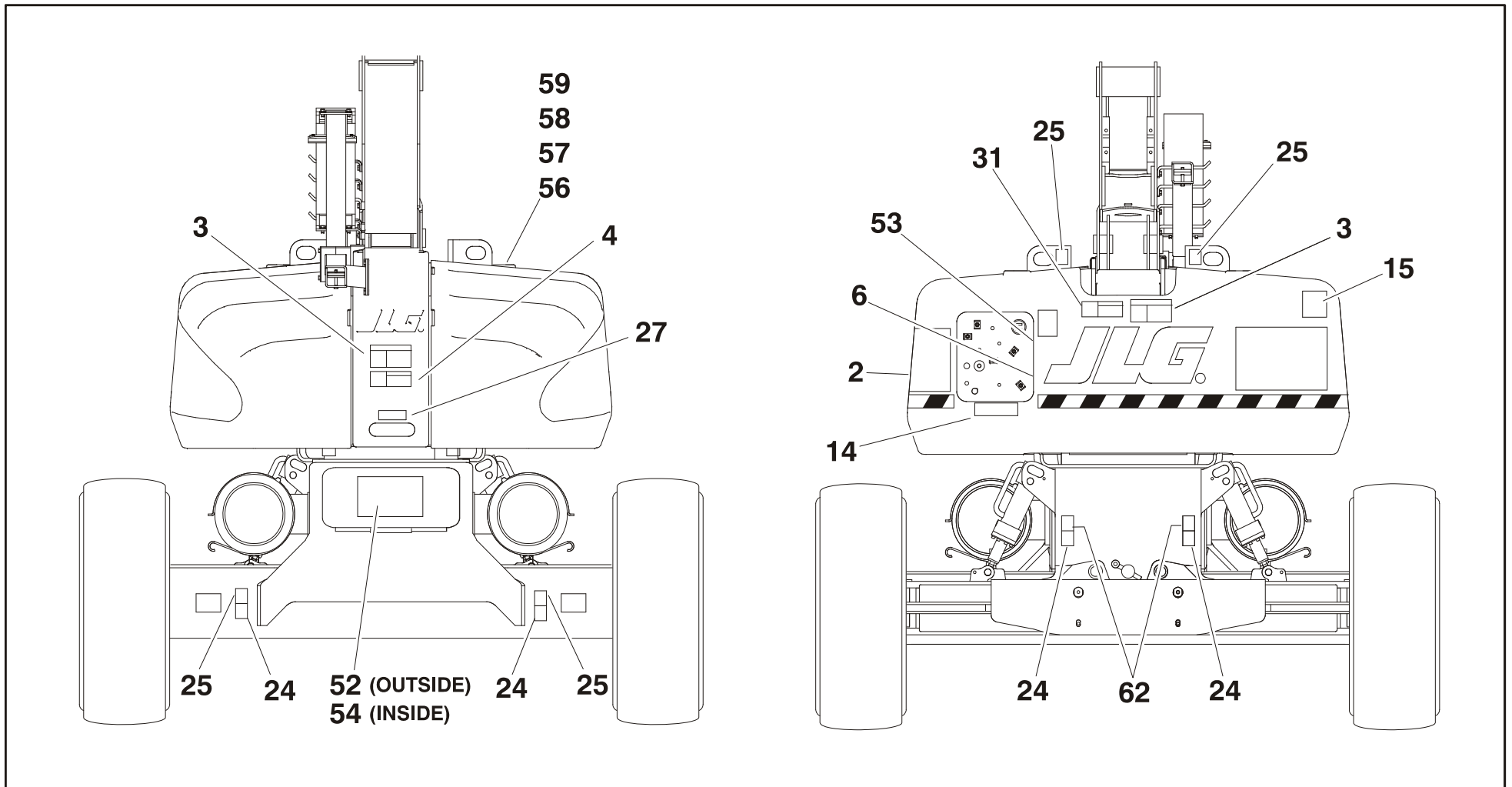

Figure 4-5. Decal Installation - Sheet 1 of 4



**SECTION 4 - MACHINE OPERATION**



**Figure 4-6. Decal Installation - Sheet 2 of 4**



## SECTION 4 - MACHINE OPERATION

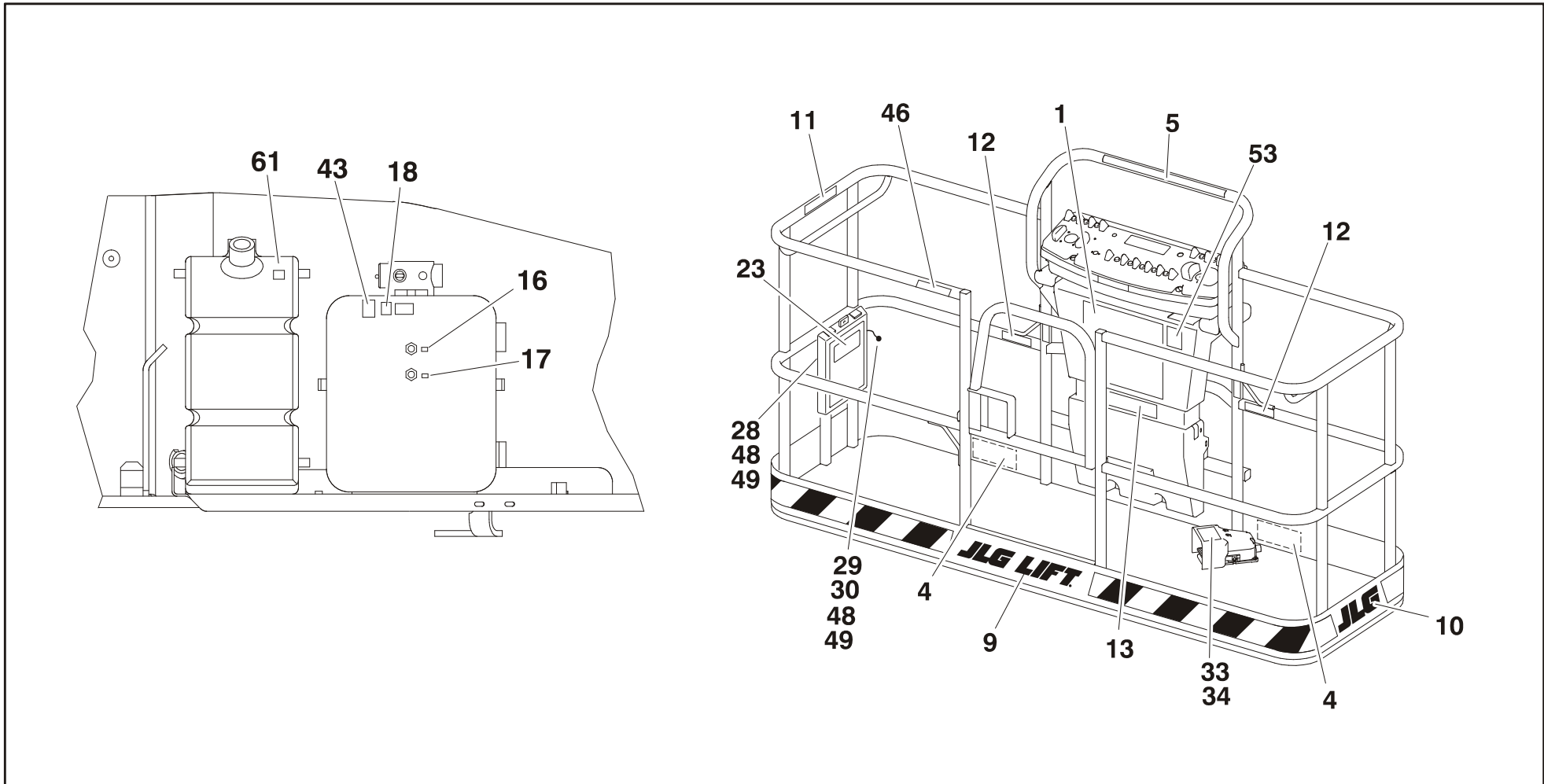

Figure 4-7. Decal Installation - Sheet 3 of 4





## SECTION 4 - MACHINE OPERATION

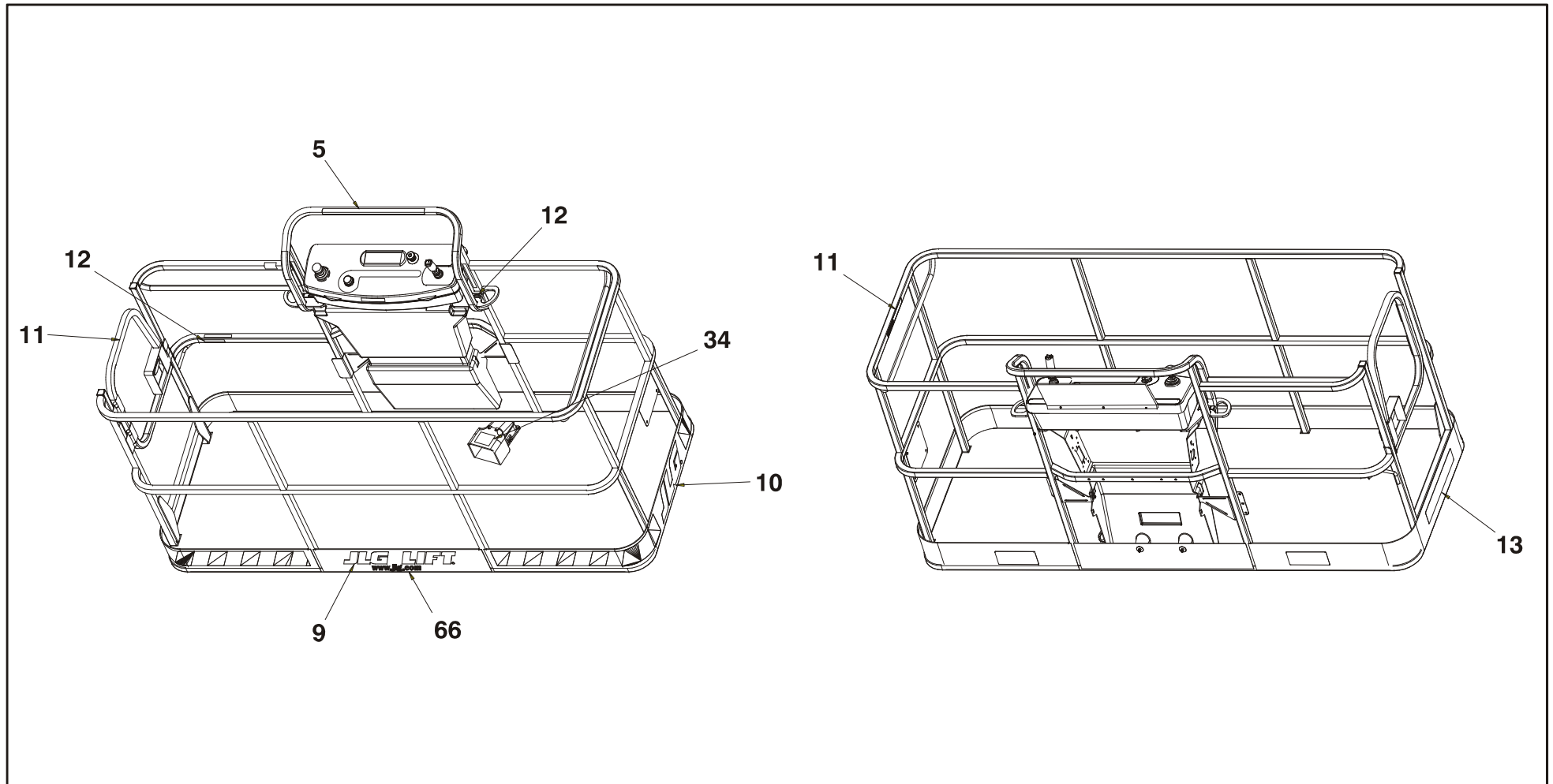

Figure 4-8. Decal Installation - Sheet 4 of 4



## SECTION 4 - MACHINE OPERATION

**Table 4-1. Decal Legend - Prior to S/N 0300141450**

Item #	ANSI 0270129-14	CE/Aus 0275062-5	Japan 0270146-12	Korean/Eng 0270148-13	Eng/Spanish 0270150-13	Eng/French 0270152-14	Chinese/Eng 0270154-13	Port./Spa 0270156-13
1	1703797	1705921	1703926	1703927	1703923	1703924	1703925	1703928
2	1704575	1705822	1704667	1704668	--	--	--	--
3	1703805	--	1703938	1703939	1703935	1703936	1703937	1703940
4	1703804	1701518	1703950	1703951	1703947	1703948	1703949	1703952
5	1704661	--	--	--	1704661	1704661	--	--
6	1707035	--	--	--	1707035	1707035	--	--
7	--	--	--	--	--	--	--	--
8	--	--	--	--	--	--	--	--
9	--	--	--	--	--	--	--	--
10	--	--	--	--	--	--	--	--
11	1702868	--	--	--	1704001	1704000	--	1704002
12	1704277	1704277	1704277	1704277	1704277	1704277	1704277	1704277
13	1701645	1705978	1701645	1707058	1707056	1707055	1707060	1707134
14	1707013	1705978	1707013	1707042	1707049	1707047	1707044	1707133
15	3251813	1705084	--	--	3251813	3251813	--	3251813
16	1701502	1701502	1701502	1701502	1701502	1701502	1701502	1701502
17	1701503	1701503	1701503	1701503	1701503	1701503	1701503	1701503



**SECTION 4 - MACHINE OPERATION**

**Table 4-1. Decal Legend - Prior to S/N 0300141450**

Item #	ANSI 0270129-14	CE/Aus 0275062-5	Japan 0270146-12	Korean/Eng 0270148-13	Eng/Spanish 0270150-13	Eng/French 0270152-14	Chinese/Eng 0270154-13	Port./Spa 0270156-13
18	1701504	1701504	1701504	1701504	1701504	1701504	1701504	1701504
19	--	--	--	--	1704007	1704006	--	1704008
20	1702631	1702631	1702631	1702631	1702631	1702631	1702631	1702631
21	--	--	--	--	--	--	--	--
22	1706948	3252523	1706948	1706948	1706948	1706948	1706948	1706948
23	1701509	1701509	1701509	1701509	1701509	1701509	1701509	1701509
24	1702300	1702300	1702300	1702300	1702300	1702300	1702300	1702300
25	1701500	1701500	1701500	1701500	1701500	1701500	1701500	1701500
26	1701529	1701529	1701529	1701529	1701529	1701529	1701529	1701529
27	--	--	--	--	--	--	--	--
28	--	--	--	--	--	--	--	--
29	--	--	--	--	--	--	--	--
30	--	--	--	--	--	--	--	--
31	1703953	1701518	1703944	1703945	1703941	1703942	1703943	1703946
32	--	--	--	--	--	--	--	--
33	--	--	--	--	--	--	--	--
34	3252347	1705828	1703980	1703981	1703983	1703984	1703982	1703985
35	1704708	1704708	1704708	1704708	1704708	--	1704708	1704708



## SECTION 4 - MACHINE OPERATION

**Table 4-1. Decal Legend - Prior to S/N 0300141450**

Item #	ANSI 0270129-14	CE/Aus 0275062-5	Japan 0270146-12	Korean/Eng 0270148-13	Eng/Spanish 0270150-13	Eng/French 0270152-14	Chinese/Eng 0270154-13	Port./Spa 0270156-13
36	1701644	1701644	1701644	1701644	1701644	1701644	1701644	1701644
37	1704705	1704705	1704705	1704705	1704705	1704705	1704705	1704705
38	1702901	1706392	1704119	1704120	1704117	1704116	1704121	1704118
39	--	--	--	--	--	1705514	--	--
40	1701501	1701501	1701501	1701501	1701501	1701501	1701501	1701501
41	1704248	1706378	1704331	1704332	1704328	1704329	1704333	1704330
42	1702155	--	1702155	1702155	1702155	1702155	1702155	1702155
43	1704412	--	1704412	1704412	1704412	1704412	1704412	1704412
44	--	--	--	--	--	--	--	--
45	--	--	--	--	--	--	--	--
46	--	--	--	--	--	--	--	--
47	--	--	--	--	--	--	--	--
48	--	--	--	--	--	--	--	--
49	--	--	--	--	--	--	--	--
50	--	--	--	--	--	--	--	--
51	1703813	1705670	1704342	1704343	1704339	1704340	1704344	1704341
52	3252673	1706377	3252738	3252739	3252740	3252743	3252741	3252742
53	--	--	--	--	--	--	--	--



**SECTION 4 - MACHINE OPERATION**

**Table 4-1. Decal Legend - Prior to S/N 0300141450**

Item #	ANSI 0270129-14	CE/Aus 0275062-5	Japan 0270146-12	Korean/Eng 0270148-13	Eng/Spanish 0270150-13	Eng/French 0270152-14	Chinese/Eng 0270154-13	Port./Spa 0270156-13
54	1704254	--	1704254	1704254	1704254	1704254	1704254	1704254
55	--	--	--	--	--	--	--	--
56	--	--	--	--	--	--	--	--
57	--	--	--	--	--	--	--	--
58	--	--	--	--	--	--	--	--
59	--	--	--	--	--	--	--	--
60	--	--	--	--	1703929	1703930	1703931	1703934
61	--	--	--	--	--	--	--	--
62	1701499	1701499	1701499	1701499	1701499	1701499	1701499	1701499
63	1702391	1701517	1701517	1701517	1701517	1701517	1701517	1701517
64	1704728	1704728	1704671	1704670	1704732	1704733	1704371	1704618
65	--	--	--	--	--	--	--	--
66	1704885	1704885	1704885	1704885	1704885	1704885	1704885	1704885
67	--	--	--	--	--	--	--	--
68	--	--	--	--	--	--	--	--
69	1705351	--	--	1705427	1705910	1705429	--	--
70	--	--	--	--	--	--	--	--



## SECTION 4 - MACHINE OPERATION

**Table 4-2. Decal Legend - S/N 0300141450 to Present**

Item #	ANSI 0270129-15	CE/Aus 0275062-5	Japan 0270146-13	Korean/Eng 0270148-14	Eng/Spanish 0270150-14	Eng/French 0270152-15	Chinese/Eng 0270154-14	Port./Spa 0270156-14
1	1703797	1705921	1703926	1703927	1703923	1703924	1703925	1703928
2	1704575	1705822	1704667	1704668	--	--	--	--
3	1703805	--	1703938	1703939	1703935	1703936	1703937	1703940
4	1703804	1701518	1703950	1703951	1703947	1703948	1703949	1703952
5	1704661	--	--	--	1704661	1704661	--	--
6	1707035	--	--	--	1707035	1707035	--	--
7	--	--	--	--	--	--	--	--
8	--	--	--	--	--	--	--	--
9	--	--	--	--	--	--	--	--
10	--	--	--	--	--	--	--	--
11	1702868	--	--	--	1704001	1704000	--	1704002
12	1704277	1704277	1704277	1704277	1704277	1704277	1704277	1704277
13	1001121801	1705978	1001121801	1001121918	1001121805	1001121803	1001121810	1001121920
14	1001121814	1705978	1001121814	1001121921	1001121818	1001121816	1001121823	1001121923
15	3251813	1705084	--	--	3251813	3251813	--	3251813
16	1701502	1701502	1701502	1701502	1701502	1701502	1701502	1701502
17	1701503	1701503	1701503	1701503	1701503	1701503	1701503	1701503



**SECTION 4 - MACHINE OPERATION**

**Table 4-2. Decal Legend - S/N 0300141450 to Present**

Item #	ANSI 0270129-15	CE/Aus 0275062-5	Japan 0270146-13	Korean/Eng 0270148-14	Eng/Spanish 0270150-14	Eng/French 0270152-15	Chinese/Eng 0270154-14	Port./Spa 0270156-14
18	1701504	1701504	1701504	1701504	1701504	1701504	1701504	1701504
19	--	--	--	--	1704007	1704006	--	1704008
20	1702631	1702631	1702631	1702631	1702631	1702631	1702631	1702631
21	--	--	--	--	--	--	--	--
22	1706948	3252523	1706948	1706948	1706948	1706948	1706948	1706948
23	1701509	1701509	1701509	1701509	1701509	1701509	1701509	1701509
24	1702300	1702300	1702300	1702300	1702300	1702300	1702300	1702300
25	1701500	1701500	1701500	1701500	1701500	1701500	1701500	1701500
26	1701529	1701529	1701529	1701529	1701529	1701529	1701529	1701529
27	--	--	--	--	--	--	--	--
28	--	--	--	--	--	--	--	--
29	--	--	--	--	--	--	--	--
30	--	--	--	--	--	--	--	--
31	1703953	1701518	1703944	1703945	1703941	1703942	1703943	1703946
32	--	--	--	--	--	--	--	--
33	--	--	--	--	--	--	--	--
34	3252347	1705828	1703980	1703981	1703983	1703984	1703982	1703985
35	1704708	1704708	1704708	1704708	1704708	--	1704708	1704708



## SECTION 4 - MACHINE OPERATION

**Table 4-2. Decal Legend - S/N 0300141450 to Present**

Item #	ANSI 0270129-15	CE/Aus 0275062-5	Japan 0270146-13	Korean/Eng 0270148-14	Eng/Spanish 0270150-14	Eng/French 0270152-15	Chinese/Eng 0270154-14	Port./Spa 0270156-14
36	1701644	1701644	1701644	1701644	1701644	1701644	1701644	1701644
37	1704705	1704705	1704705	1704705	1704705	1704705	1704705	1704705
38	1702901	1706392	1704119	1704120	1704117	1704116	1704121	1704118
39	--	--	--	--	--	1705514	--	--
40	1701501	1701501	1701501	1701501	1701501	1701501	1701501	1701501
41	1704248	1706378	1704331	1704332	1704328	1704329	1704333	1704330
42	1702155	--	1702155	1702155	1702155	1702155	1702155	1702155
43	1704412	--	1704412	1704412	1704412	1704412	1704412	1704412
44	--	--	--	--	--	--	--	--
45	--	--	--	--	--	--	--	--
46	--	--	--	--	--	--	--	--
47	--	--	--	--	--	--	--	--
48	--	--	--	--	--	--	--	--
49	--	--	--	--	--	--	--	--
50	--	--	--	--	--	--	--	--
51	1703813	1705670	1704342	1704343	1704339	1704340	1704344	1704341
52	3252673	1706377	3252738	3252739	3252740	3252743	3252741	3252742
53	--	--	--	--	--	--	--	--





**SECTION 4 - MACHINE OPERATION**

**Table 4-2. Decal Legend - S/N 0300141450 to Present**

Item #	ANSI 0270129-15	CE/Aus 0275062-5	Japan 0270146-13	Korean/Eng 0270148-14	Eng/Spanish 0270150-14	Eng/French 0270152-15	Chinese/Eng 0270154-14	Port./Spa 0270156-14
54	1704254	--	1704254	1704254	1704254	1704254	1704254	1704254
55	--	--	--	--	--	--	--	--
56	--	--	--	--	--	--	--	--
57	--	--	--	--	--	--	--	--
58	--	--	--	--	--	--	--	--
59	--	--	--	--	--	--	--	--
60	--	--	--	--	1703929	1703930	1703931	1703934
61	--	--	--	--	--	--	--	--
62	1701499	1701499	1701499	1701499	1701499	1701499	1701499	1701499
63	1702391	1701517	1701517	1701517	1701517	1701517	1701517	1701517
64	1704728	1704728	1704671	1704670	1704732	1704733	1704371	1704618
65	--	--	--	--	--	--	--	--
66	1704885	1704885	1704885	1704885	1704885	1704885	1704885	1704885
67	--	--	--	--		--	--	--
68	--	--	--	--		--	--	--
69	1705351	--	--	1705427	1705910	1705429	--	--
70	--	--	--	--		--	--	--



## SECTION 4 - MACHINE OPERATION

---



**NOTES:**

---

---

---

---

---

---

---

---

---

---

---

---

---

---

---

---

---

---

---

---

---

---

---

---

---

---

---

---

---

---

---

---

---

---

---

---

---

---

---

---

---

---

---

---

---

---



## SECTION 5 - EMERGENCY PROCEDURES

# SECTION 5. EMERGENCY PROCEDURES

## 5.1 GENERAL

This section explains the steps to be taken in case of an emergency situation while operating.

## 5.2 INCIDENT NOTIFICATION

JLG Industries, Inc. must be notified immediately of any incident involving a JLG product. Even if no injury or property damage is evident, the factory should be contacted by telephone and provided with all necessary details.

In USA:

JLG Phone: 877-JLG-SAFE (554-7233)  
(8am till 4:45pm EST)

Outside USA:

240-420-2661

E-mail:

ProductSafety@JLG.com

Failure to notify the manufacturer of an incident involving a JLG Industries product within 48 hours of such an occurrence may void any warranty consideration on that particular machine.

### **NOTICE**

**FOLLOWING ANY ACCIDENT, THOROUGHLY INSPECT THE MACHINE AND TEST ALL FUNCTIONS FIRST FROM THE GROUND CONTROLS, THEN FROM THE PLATFORM CONTROLS. DO NOT LIFT ABOVE 10 FT. (3 M) UNTIL YOU ARE SURE THAT ALL DAMAGE HAS BEEN REPAIRED, IF REQUIRED, AND THAT ALL CONTROLS ARE OPERATING CORRECTLY.**

## 5.3 EMERGENCY OPERATION

### Operator Unable to Control Machine

IF THE PLATFORM OPERATOR IS PINNED, TRAPPED OR UNABLE TO OPERATE OR CONTROL MACHINE:

1. Other personnel should operate the machine from ground controls only as required.
2. Other qualified personnel on the platform may use the platform controls. **DO NOT CONTINUE OPERATION IF CONTROLS DO NOT FUNCTION PROPERLY.**
3. Cranes, forklift trucks or other equipment can be used to remove platform occupants and stabilize motion of the machine.



## SECTION 5 - EMERGENCY PROCEDURES

### Platform or Boom Caught Overhead

If the platform or boom becomes jammed or snagged in overhead structures or equipment, rescue platform occupants prior to freeing the machine.

### 5.4 EMERGENCY TOWING PROCEDURES

Towing this machine is prohibited, unless properly equipped. However, provisions for moving the machine have been incorporated. For specific procedures, refer to Section 4.

### 5.5 MANUAL DESCENT SYSTEM

The manual descent system is used, in the event of total power failure, to lower the boom using gravity. To operate the manual descent system, proceed as follows:

#### TELESCOPING IN AND LOWERING THE BOOM

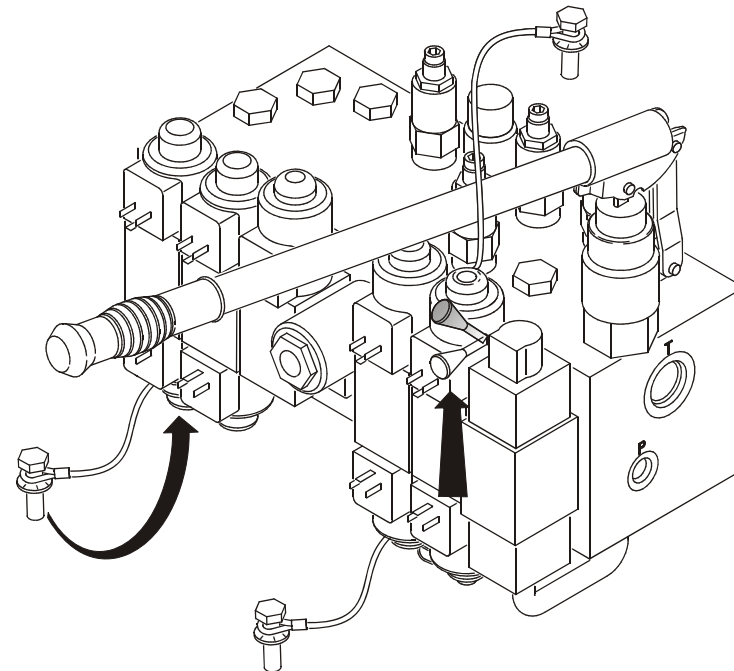

1. Install the spool plug in the location shown and push the control lever on the valve up.
2. Install the handle into the hand pump and pump the handle until the desired platform position is reached.
3. Push the control lever down when complete. Remove the handle from the hand pump and the spool plug from the valve.

## SECTION 5 - EMERGENCY PROCEDURES

### LOWERING THE BOOM

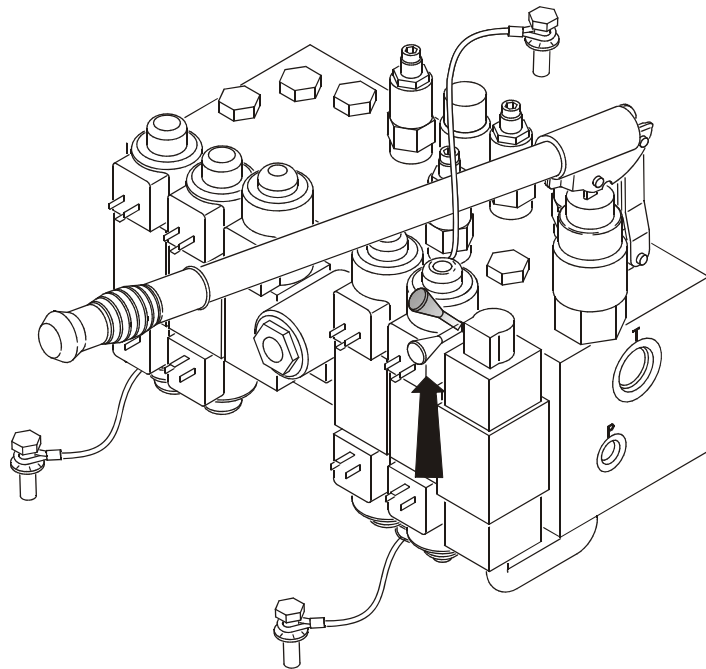

1. Push the control lever on the valve up.
2. Install the handle into the hand pump and pump the handle until the desired platform position is reached.
3. Push the control lever down when complete. Remove the handle from the hand pump.

### SWING RIGHT

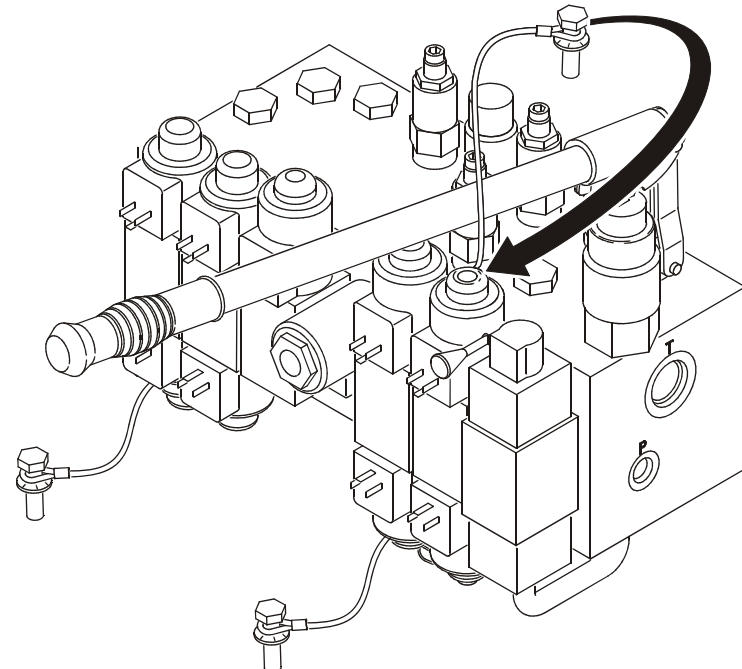

1. Install the spool plug in the location shown.
2. Install the handle into the hand pump and pump the handle until the desired platform position is reached.
3. Remove the handle from the hand pump.

## SECTION 5 - EMERGENCY PROCEDURES

---

### SWING LEFT

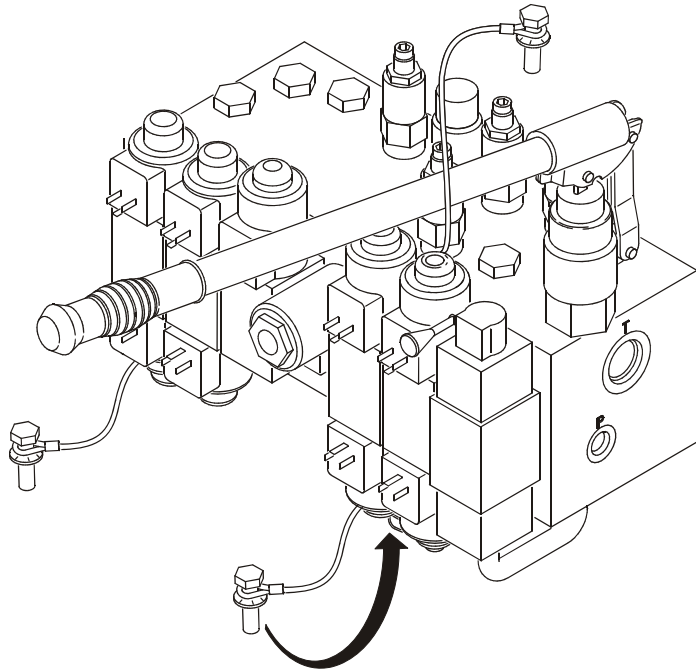

1. Install the spool plug in the location shown.
2. Install the handle into the hand pump and pump the handle until the desired platform position reached.
3. Remove the handle from the hand pump.

**⚠ CAUTION**

**REMOVE ALL SPOOL PLUGS BEFORE RETURNING UNIT TO SERVICE.**

SECTION 5 - EMERGENCY PROCEDURES

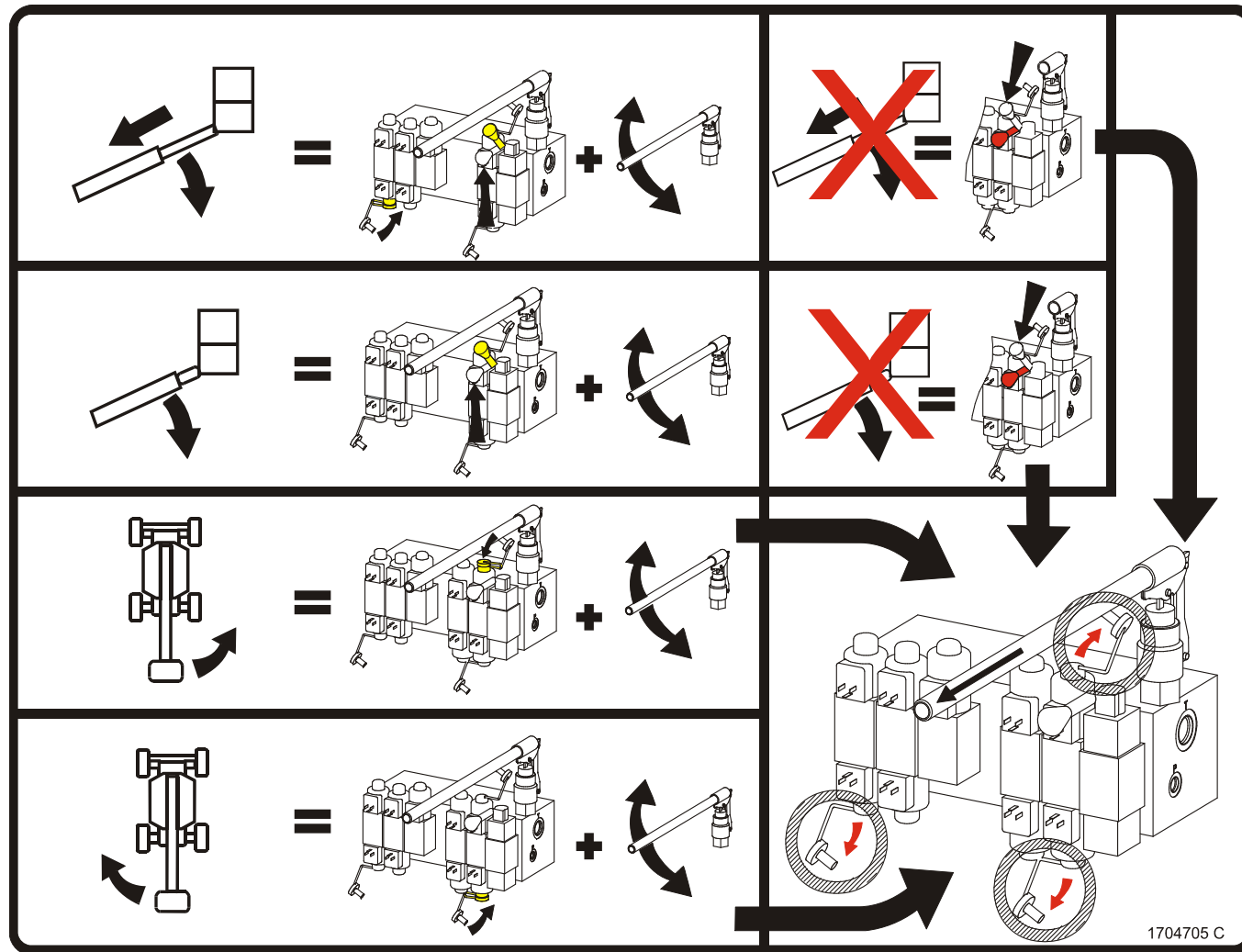

Figure 5-1. Manual Descent Decal



## SECTION 5 - EMERGENCY PROCEDURES



**NOTES:**

---

---

---

---

---

---

---

---

---

---

---

---

---

---

---

---

---

---

---

---

---

---

---

---

---

---

---

---

---

---

---

---

---

---

---

---

---

---

---

---

---

---

---

---

---

---

---

---

---

---

---

---

---

---





**SECTION 6 - GENERAL SPECIFICATIONS & OPERATOR MAINTENANCE**

**SECTION 6. GENERAL SPECIFICATIONS & OPERATOR MAINTENANCE**

**6.1 INTRODUCTION**

This section of the manual provides additional necessary information to the operator for proper operation and maintenance of this machine.

The maintenance portion of this section is intended as information to assist the machine operator to perform daily maintenance tasks only, and does not replace the more thorough Preventive Maintenance and Inspection Schedule included in the Service and Maintenance Manual.

**Other Publications Available:**

- Service and Maintenance Manual- ANSI, CSA..... 3121117
- Service and Maintenance Manual - CE ..... 3121813
- Illustrated Parts Manual - ANSI, CSA..... 3121118
- Illustrated Parts Manual - CE ..... 3121814

**6.2 OPERATING SPECIFICATIONS**

**Table 6-1. Operating Specifications - Prior to S/N 0300141450**

Maximum Work Load (Capacity) Unrestricted:	500 lb (230 kg)
Maximum Travel Grade (Gradeability) with Boom retracted and approximately horizontal. Tower Boom fully lowered.	30%
Maximum Travel Grade (Side Slope) with Boom retracted and approximately hori- zontal. Tower Boom fully lowered.	5°
Tilt Alarm Setting (See Section 3) ANSI, CSA CE E/M600 & E/M600J CE E/M 600JP	5° 4° 3°
Maximum Vertical Platform Height:	60 ft. (18.29 m)
Maximum Horizontal Platform Reach E600 E600J	43 ft. (13.11 m) 42 ft. 9 in. (13.11 m)
Machine Width 2WD 4WD	7 ft. 11 7/16 in. (2.42 m) 7 ft. 11 3/8 in. (2.42 m)



## SECTION 6 - GENERAL SPECIFICATIONS & OPERATOR MAINTENANCE

**Table 6-1. Operating Specifications - Prior to S/N 0300141450**

Machine Length	
E/M600	30 ft. 11 5/16 in. (9.43 m)
E/M600J	30 ft. 8 15/16 in. (9.37 m)
E/M600JP	33 ft. 3 3/4 in. (10.15 m)
Turning Radius (outside)	15 ft. 3 in. (4.65 m)
Turning Radius (inside)	4 ft. (1.23 m)
Maximum Tire Load:	7700 lbs. (3493 kg)
Maximum Ground Bearing Pressure	
E600J/M600J	52 psi (3.7 kg/cm <sup>2</sup> )
E600JP/M600JP	51 psi (3.6 kg/cm <sup>2</sup> )
Maximum Drive Speed:	3.0 mph (1.3 m/s)
Electrical System Voltage	48 volts
Maximum Hydraulic System Pressure	3200 psi (221 Bar)
Maximum Wind Speed	28 mph (12.5 m/s)
Maximum Manual Force	400N

**Table 6-1. Operating Specifications - Prior to S/N 0300141450**

Gross Machine Weight (Platform Empty) Prior to S/N 0300104944	
E600J/M600J	16,300 lb. (7,393 kg)
E600JP/M600JP	16,800 lb. (7,620 kg)
Gross Machine Weight (Platform Empty) S/N 0300104944 to Present	
E600J/M600J	16,710 lb. (7,580 kg)
E600JP/M600JP	17,210 lb. (7,806 kg)

**Table 6-2. Operating Specifications - S/N 0300141450 to Present**

Maximum Work Load (Capacity) ANSI Markets Unrestricted:	500 lb. (227 kg)
Maximum Work Load (Capacity) CE & Australia Markets Unrestricted:	500 lb. (230 kg)
Maximum Travel Grade (Gradeability) with Boom retracted and approximately horizontal. Tower Boom fully lowered.	30%
Maximum Travel Grade (Side Slope) with Boom retracted and approximately hori- zontal. Tower Boom fully lowered.	5°



## SECTION 6 - GENERAL SPECIFICATIONS & OPERATOR MAINTENANCE

**Table 6-2. Operating Specifications - S/N 0300141450 to Present**

Tilt Alarm Setting (See Section 3)	
ANSI, CSA	5°
CE E/M600 & E/M600J	4°
CE E/M 600JP	3°
Maximum Vertical Platform Height:	60 ft. (18.29 m)
Maximum Horizontal Platform Reach	
E600	43 ft. (13.11 m)
E600J	42 ft. 9 in. (13.11 m)
Machine Width	
2WD	7 ft. 11 7/16 in. (2.42 m)
4WD	7 ft. 11 3/8 in. (2.42 m)
Machine Length	
E/M600	30 ft. 11 5/16 in. (9.43 m)
E/M600J	30 ft. 8 15/16 in. (9.37 m)
E/M600JP	33 ft. 3 3/4 in. (10.15 m)
Turning Radius (outside)	15 ft. 3 in. (4.65 m)
Turning Radius (inside)	4 ft. (1.23 m)
Maximum Tire Load:	7700 lbs. (3493 kg)
Maximum Ground Bearing Pressure	
E600J/M600J	52 psi (3.7 kg/cm <sup>2</sup> )
E600JP/M600JP	51 psi (3.6 kg/cm <sup>2</sup> )
Maximum Drive Speed:	3.0 mph (1.3 m/s)

**Table 6-2. Operating Specifications - S/N 0300141450 to Present**

Electrical System Voltage	48 volts
Maximum Hydraulic System Pressure	3200 psi (221 Bar)
Maximum Wind Speed	28 mph (12.5 m/s)
Maximum Manual Force	400N
Gross Machine Weight (Platform Empty) Prior to S/N 0300104944	
E600J/M600J	16,300 lb. (7,393 kg)
E600JP/M600JP	16,800 lb. (7,620 kg)
Gross Machine Weight (Platform Empty) S/N 0300104944 to Present	
E600J/M600J	16,710 lb. (7,580 kg)
E600JP/M600JP	17,210 lb. (7,806 kg)



## SECTION 6 - GENERAL SPECIFICATIONS & OPERATOR MAINTENANCE

### Capacities

**Table 6-3. Capacities**

Generator Fuel Tank (M Models Only)	13 gallons (49.2 liters)
Hydraulic Tank Prior to S/N 51941 S/N 51941 to Present	15 gallons (57 liters) 15.9 gal.(60.2 L) 12.4 gal. (46.9 L) to full mark
Drive Hub	0.4 gal. (1.5 liters)

### Tires

**Table 6-4. Tires**

Size	Type	Pressure
36/14 LL-22.5	pneumatic	55 psi (4.0 Bar)
36/14 LL-22.5	foam filled	N/A



## SECTION 6 - GENERAL SPECIFICATIONS & OPERATOR MAINTENANCE

### Hydraulic Oil

Table 6-5. Hydraulic Oil

Hydraulic System Operating Temperature Range	S.A.E. Viscosity Grade
+0 to +180 F (-18 to +83 C)	10W
+0 to +210 F (-18 to +99 C)	10W-20, 10W30
+50 to +210 F (+10 to +99 C)	20W-20

**NOTE:** Hydraulic oils must have anti-wear qualities at least to API Service Classification GL-3, and sufficient chemical stability for mobile hydraulic system service.

Aside from JLG recommendations, it is not advisable to mix oils of different brands or types, as they may not contain the same required additives or be of comparable viscosities. If use of hydraulic oil other than Mobil DTE 11M is desired, contact JLG Industries for proper recommendations.

Table 6-6. Mobil DTE 11M Specs

ISO Viscosity Grade	#15
Gravity API	31.9
Pour Point, Max	-40 F (-40 C)
Flash Point, Min.	330 F (166 C)
Viscosity	
at 40° C	15 cSt
at 100° C	4.1 cSt
at 100° F	80 SUS
at 210° F	43 SUS
cp at -30° F	3.200
Viscosity Index	140



## SECTION 6 - GENERAL SPECIFICATIONS & OPERATOR MAINTENANCE

### Major Component Weights

Table 6-7. Component Weights

Component	Pounds	Kilograms
Frame (bare)	1381	626
T/T (bare)	2093	950
Boom Assembly (E/M 600)	4464	2025
Boom Assembly (E/M 600J)	4464	2025
Tire & Wheel	226	102.5
Swing Drive	70	32
Swing Bearing	100	45.4
Platform Console	25	11
Side Entry Platform - 30x72 (bare)	175	80
Side Entry Platform - 30x48 (bare)	144	66
Counterweight	2560	1161

### Serial Number Location

A serial number plate is affixed to the right side of the frame. If the serial number plate is damaged or missing, the machine serial number is stamped on the left side of the frame at the top.

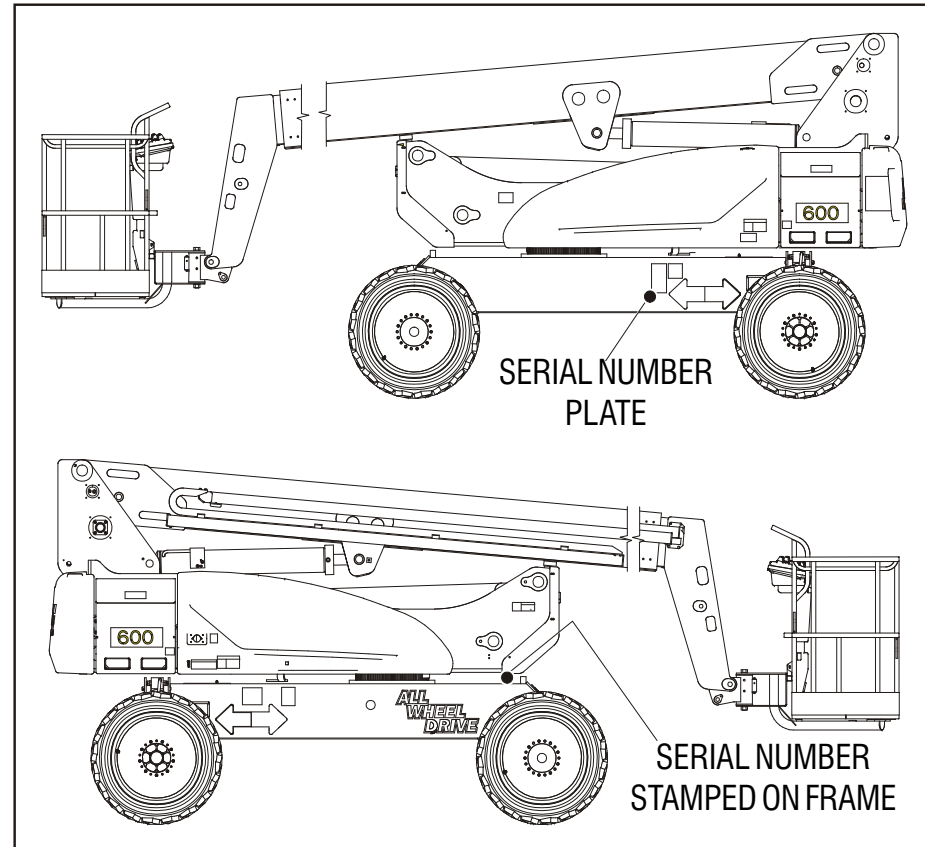

Figure 6-1. Serial Number Location

## SECTION 6 - GENERAL SPECIFICATIONS & OPERATOR MAINTENANCE

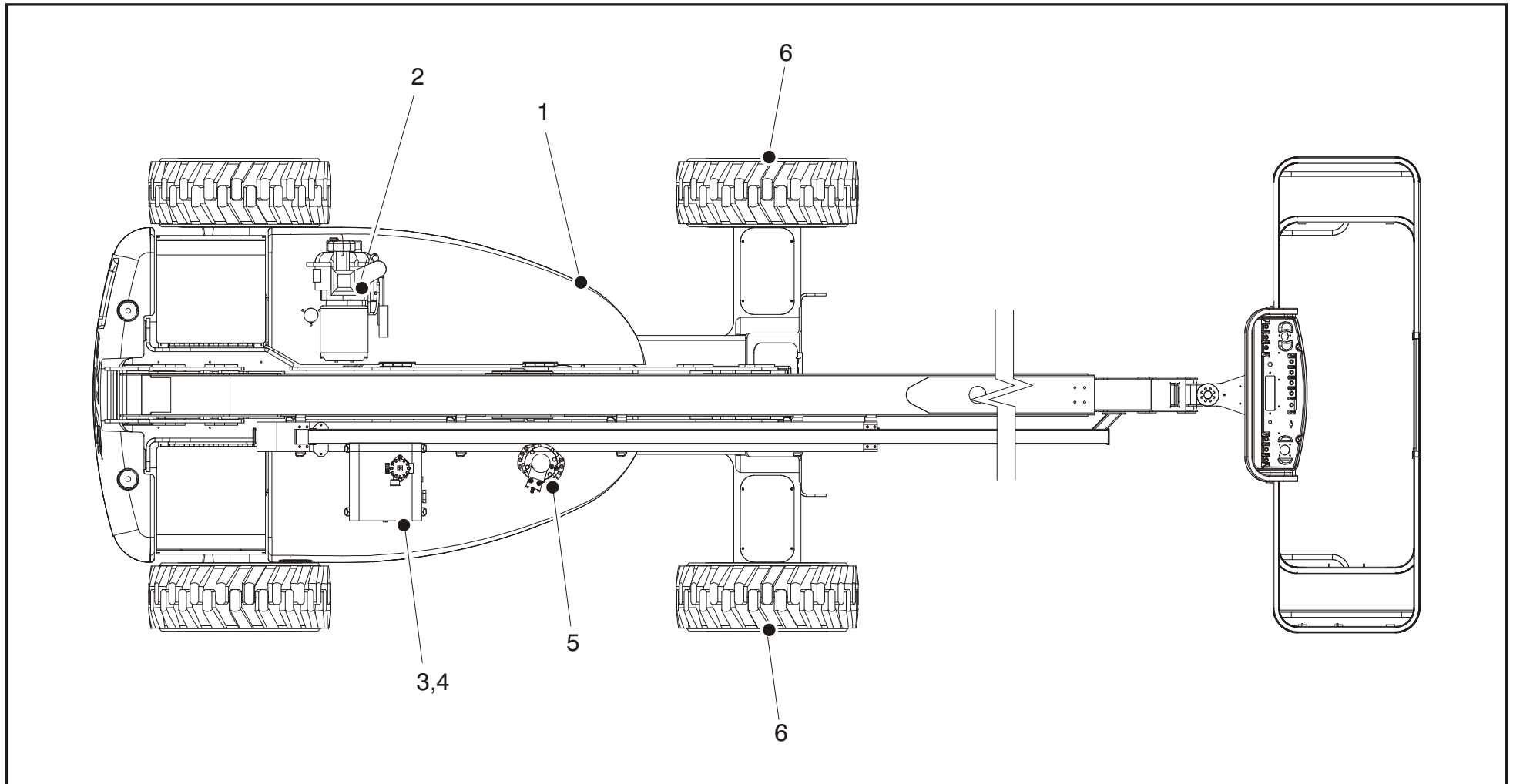

Figure 6-2. Operator Maintenance and Lubrication Diagram



## SECTION 6 - GENERAL SPECIFICATIONS & OPERATOR MAINTENANCE

### 6.3 OPERATOR MAINTENANCE

**NOTE:** The following numbers correspond to those in Figure 6-2., Operator Maintenance and Lubrication Diagram.

**Table 6-8. Lubrication Specifications.**

KEY	SPECIFICATIONS
MPG	Multipurpose Grease having a minimum dripping point of 350 degrees F. Excellent water resistance and adhesive qualities; and being of extreme pressure type (Timken OK 40 pounds minimum).
EPGL	Extreme Pressure Gear Lube (oil) meeting API Service Classification GL-5 or Mil-Spec Mil-L-2105.
HO	Hydraulic Oil. Mobil DTE-11M
OG*	Open Gear Lube - Tribol Molub-Alloy 936 Open Gear Compound. (JLG Part No. 3020027)
BG*	Bearing Grease (JLG Part No. 3020029) Mobilith SHA 460.
LL	Synthetic Lithium Lubricant, Gredag 741 Grease. (JLG Part No. 3020022)
EO	Engine (crankcase) Oil. Gas - API SF/SG class, MIL-L-2104. Diesel - API CC/CD class, MIL-L-2104B/MIL-L-2104C.

\*MPG may be substituted for these lubricants, if necessary, but service intervals will be reduced.

#### NOTICE

**LUBRICATION INTERVALS ARE BASED ON MACHINE OPERATION UNDER NORMAL CONDITIONS. FOR MACHINES USED IN MULTI-SHIFT OPERATIONS AND/OR EXPOSED TO HOSTILE ENVIRONMENTS OR CONDITIONS, LUBRICATION FREQUENCIES MUST BE INCREASED ACCORDINGLY.**

**NOTE:** It is recommended as a good practice to replace all filters at the same time.

1. Swing Bearing - Internal Ball Bearing



Lube Point(s) - 1 Grease Fittings

Capacity - A/R

Lube - MPG

Interval - Every 3 months or 150 hrs of operation





## SECTION 6 - GENERAL SPECIFICATIONS & OPERATOR MAINTENANCE

### 2. Generator Engine (If Equipped)



Lube Point(s) - Fill Cap

Capacity - Refer to engine manual

Lube - EO

Interval - Check daily. Change in accordance with engine manual.

## SECTION 6 - GENERAL SPECIFICATIONS & OPERATOR MAINTENANCE

### 3. Hydraulic Tank



Lube Point(s) - Fill Cap

Capacity -

Prior to S/N 51941 - 15 gal. tank (56.7 L)

S/N 51941 to present - 15.9 gal. system (56.7L)

12.4 gal. (46.9 L) to Full Mark

Lube - HO

Interval - Check Level daily; Change every 2 years or 1200 hours of operation.

### 4. Hydraulic Filter

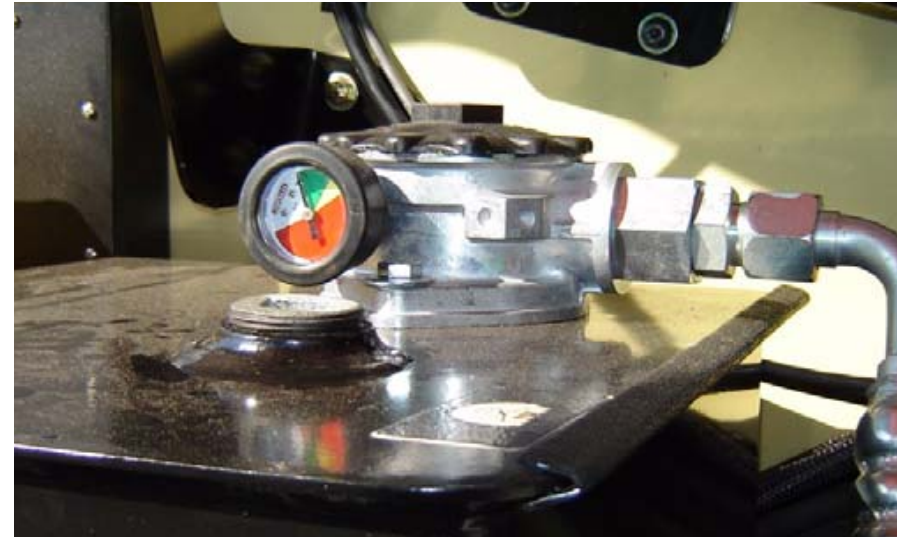

Interval - Change after first 50 hrs. and every 6 months or 300 hrs. thereafter or as indicated by Condition Indicator.

Comments - Under certain conditions, it may be necessary to replace the filter on a more frequent basis.

## SECTION 6 - GENERAL SPECIFICATIONS & OPERATOR MAINTENANCE

### 5. Swing Drive Hub (S/N 58845 to Present)

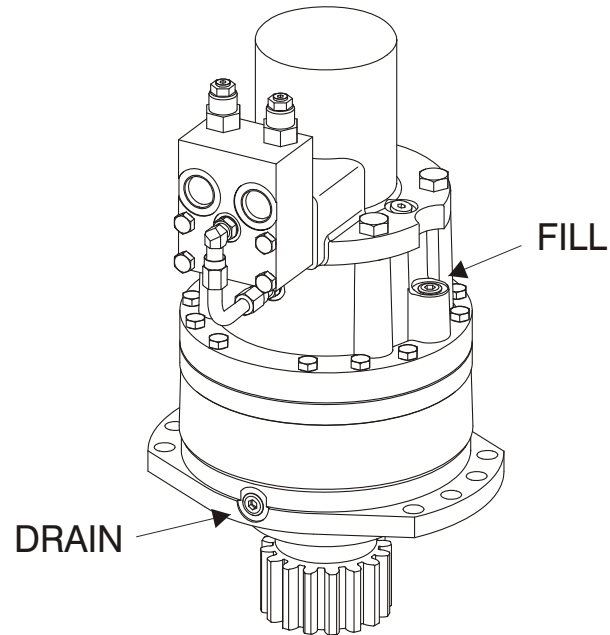

Lube Point(s) - Level/Fill Plug  
 Capacity - 24 oz. (0.7 L)  
 Lube - EPGL  
 Interval - Check level every 3 months or 150 hrs of operation; change every 2 years or 1200 hours of operation

### 6. Wheel Drive Hub



Lube Point(s) - Level/Fill Plug  
 Capacity - 0.4 gal. (1.5 L)  
 Lube - EPGL  
 Interval - Check level every 3 months or 150 hrs of operation; change every 2 years or 1200 hours of operation



## SECTION 6 - GENERAL SPECIFICATIONS & OPERATOR MAINTENANCE

### 6.4 OSCILLATING AXLE LOCKOUT TEST (IF EQUIPPED)

#### **NOTICE**

**LOCKOUT SYSTEM TEST MUST BE PERFORMED QUARTERLY, ANY TIME A SYSTEM COMPONENT IS REPLACED, OR WHEN IMPROPER SYSTEM OPERATION IS SUSPECTED.**

**NOTE:** *Ensure boom is fully retracted, lowered, and centered between drive wheels prior to beginning lockout cylinder test.*

1. Place a 6 inches (15.2 cm) high block with ascension ramp in front of left front wheel.
2. From platform control station, start engine
3. Place the Drive control lever to the forward position and carefully drive machine up ascension ramp until left front wheel is on top of block.
4. Carefully activate Swing control lever and position boom over right side of machine.
5. With boom over right side of machine, place Drive control lever to Reverse and drive machine off of block and ramp.
6. Have an assistant check to see that left front or right rear wheel remains elevated in position off of ground.
7. Carefully activate Swing control lever and return boom to stowed position (centered between drive wheels). When boom reaches center, stowed position, lockout cylinders should release and allow wheel to rest on ground, it may be necessary to activate Drive to release cylinders.
8. Place the 6 inches (15.2 cm) high block with ascension ramp in front of right front wheel.
9. Place Drive control lever to Forward and carefully drive machine up ascension ramp until right front wheel is on top of block.
10. With boom over left side of machine, place Drive control lever to Reverse and drive machine off of block and ramp.
11. Have an assistant check to see that right front or left rear wheel remains elevated in position off of ground.
12. Carefully activate Swing control lever and return boom to stowed position (centered between drive wheels). When boom reaches center, stowed position, lockout cylinders should release and allow wheel to rest on ground, it may be necessary activate Drive to release cylinders.
13. If lockout cylinders do not function properly, have qualified personnel correct the malfunction prior to any further operation.



## SECTION 6 - GENERAL SPECIFICATIONS & OPERATOR MAINTENANCE

### 6.5 TIRES & WHEELS

#### Tire Inflation

The air pressure for pneumatic tires must be equal to the air pressure that is stenciled on the side of the JLG product or rim decal for safe and proper operational characteristics.

#### Tire Damage

For pneumatic tires, JLG Industries, Inc. recommends that when any cut, rip, or tear is discovered that exposes sidewall or tread area cords in the tire, measures must be taken to remove the JLG product from service immediately. Arrangements must be made for replacement of the tire or tire assembly.

For polyurethane foam filled tires, JLG Industries, Inc. recommends that when any of the following are discovered, measures must be taken to remove the JLG product from service immediately and arrangements must be made for replacement of the tire or tire assembly.

- a smooth, even cut through the cord plies which exceeds 3 inches (7.5 cm) in total length
- any tears or rips (ragged edges) in the cord plies which exceeds 1 inch (2.5 cm) in any direction
- any punctures which exceed 1 inch in diameter

- any damage to the bead area cords of the tire

If a tire is damaged but is within the above noted criteria, the tire must be inspected on a daily basis to insure the damage has not propagated beyond the allowable criteria.

#### Tire Replacement

JLG recommends a replacement tire be the same size, ply and brand as originally installed on the machine. Please refer to the JLG Parts Manual for the part number of the approved tires for a particular machine model. If not using a JLG approved replacement tire, we recommend that replacement tires have the following characteristics:

- Equal or greater ply/load rating and size of original
- Tire tread contact width equal or greater than original
- Wheel diameter, width, and offset dimensions equal to the original
- Approved for the application by the tire manufacturer (including inflation pressure and maximum tire load)

Unless specifically approved by JLG Industries Inc. do not replace a foam filled or ballast filled tire assembly with a pneumatic tire. When selecting and installing a replacement tire, ensure that all tires are inflated to the pressure recommended

## SECTION 6 - GENERAL SPECIFICATIONS & OPERATOR MAINTENANCE

by JLG. Due to size variations between tire brands, both tires on the same axle should be the same.

### Wheel Replacement

The rims installed on each product model have been designed for stability requirements which consist of track width, tire pressure, and load capacity. Size changes such as rim width, center piece location, larger or smaller diameter, etc., without written factory recommendations, may result in an unsafe condition regarding stability.

### Wheel Installation

It is extremely important to apply and maintain proper wheel mounting torque.

#### **⚠ WARNING**

**WHEEL NUTS MUST BE INSTALLED AND MAINTAINED AT THE PROPER TORQUE TO PREVENT LOOSE WHEELS, BROKEN STUDS, AND POSSIBLE DANGEROUS SEPARATION OF WHEEL FROM THE AXLE. BE SURE TO USE ONLY THE NUTS MATCHED TO THE CONE ANGLE OF THE WHEEL.**

Tighten the lug nuts to the proper torque to prevent wheels from coming loose. Use a torque wrench to tighten the fasteners. If you do not have a torque wrench, tighten the fasteners with a

lug wrench, then immediately have a service garage or dealer tighten the lug nuts to the proper torque. Over-tightening will result in breaking the studs or permanently deforming the mounting stud holes in the wheels. The proper procedure for attaching wheels is as follows:

1. Start all nuts by hand to prevent cross threading. DO NOT use a lubricant on threads or nuts.
2. Tighten nuts in the following sequence:

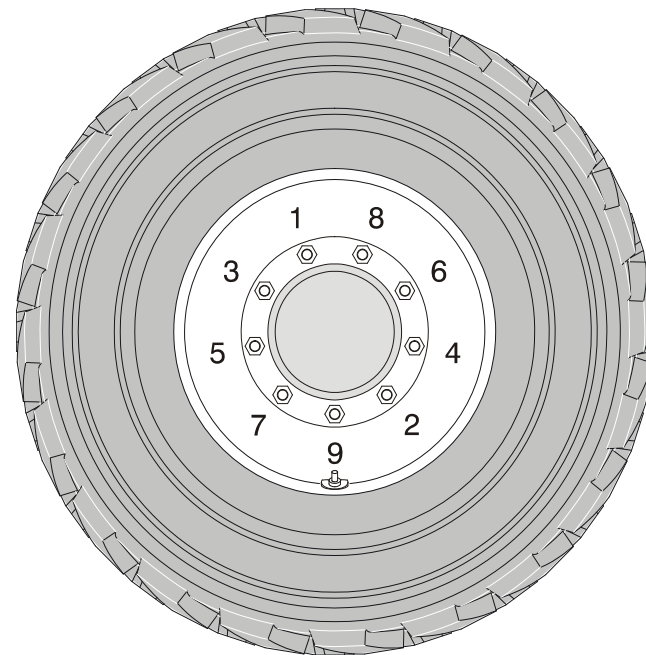



## SECTION 6 - GENERAL SPECIFICATIONS & OPERATOR MAINTENANCE

- The tightening of the nuts should be done in stages. Following the recommended sequence, tighten nuts per wheel torque chart.

**Table 6-9. Wheel Torque Chart**

TORQUE SEQUENCE		
1st Stage	2nd Stage	3rd Stage
40 ft. lbs. (55 Nm)	100 ft. lbs. (130 Nm)	170 ft. lbs. (255 Nm)

- Wheel nuts should be torqued after first 50 hours of operation and after each wheel removal. Check torque every 3 months or 150 hours of operation.

### 6.6 SUPPLEMENTAL INFORMATION

The following information is provided in accordance with the requirements of the European Machinery Directive 2006/42/EC and is only applicable to CE machines.

For electric powered machines, the equivalent continuous A-Weighted sound pressure level at the work platform is less than 70dB(A)

For combustion engine powered machines, guaranteed Sound Power Level (LWA) per European Directive 2000/14/EC (Noise Emission in the Environment by Equipment for Use Outdoors) based on test methods in accordance with Annex III, Part B, Method 1 and 0 of the directive, is 104 dB.

The vibration total value to which the hand-arm system is subjected does not exceed  $2,5 \text{ m/s}^2$ . The highest root mean square value of weighted acceleration to which the whole body is subjected does not exceed  $0,5 \text{ m/s}^2$ .



**SECTION 6 - GENERAL SPECIFICATIONS & OPERATOR MAINTENANCE**

---

 **NOTES:**

---

---

---

---

---

---

---

---

---

---

---

---

---

---

---

---

---

---

---

---

---

---

---

---

---

---

---





**SECTION 7 - INSPECTION AND REPAIR LOG**

**SECTION 7. INSPECTION AND REPAIR LOG**

Machine Serial Number \_\_\_\_\_

**Table 7-1. Inspection and Repair Log**

Date	Comments



**SECTION 7 - INSPECTION AND REPAIR LOG**

**Table 7-1. Inspection and Repair Log**

Date	Comments



An Oshkosh Corporation Company

# TRANSFER OF OWNERSHIP



www.duma-rent.com

**To Product Owner:**

If you now own but **ARE NOT** the original purchaser of the product covered by this manual, we would like to know who you are. For the purpose of receiving safety-related bulletins, it is very important to keep JLG Industries, Inc. updated with the current ownership of all JLG products. JLG maintains owner information for each JLG product and uses this information in cases where owner notification is necessary.

Please use this form to provide JLG with updated information with regard to the current ownership of JLG products. Please return completed form to the JLG Product Safety & Reliability Department via facsimile or mail to address as specified below.

Thank You,  
Product Safety & Reliability Department  
*JLG Industries, Inc.*  
13224 Fountainhead Plaza  
Hagerstown, MD 21742  
USA  
Telephone: +1-717-485-6591  
Fax: +1-301-745-3713

**NOTE:** Leased or rented units should not be included on this form.

**Mfg. Model:** \_\_\_\_\_

**Serial Number:** \_\_\_\_\_

**Previous Owner:** \_\_\_\_\_

**Address:** \_\_\_\_\_

**Country:** \_\_\_\_\_ **Telephone:** ( \_\_\_\_\_ ) \_\_\_\_\_

**Date of Transfer:** \_\_\_\_\_

**Current Owner:** \_\_\_\_\_

**Address:** \_\_\_\_\_

**Country:** \_\_\_\_\_ **Telephone:** ( \_\_\_\_\_ ) \_\_\_\_\_

**Who in your organization should we notify?**

**Name:** \_\_\_\_\_

**Title:** \_\_\_\_\_





 **WARNING:** 

**The engine exhaust from this product contains chemicals known to the State of California to cause cancer, birth defects, or other reproductive harm.**

1702961

**PROPOSITION 65  
WARNING**

- **Battery posts, terminals and related accessories contain lead and lead compounds, chemicals known to the State of California to cause cancer and reproductive harm.**
- **Batteries also contain other chemicals known to the State of California to cause cancer.**
- **Wash hands after handling.**



An Oshkosh Corporation Company

Corporate Office  
JLG Industries, Inc.  
1 JLG Drive  
McConnellsburg PA. 17233-9533  
USA

☎ (717) 485-5161

☎ (717) 485-6417

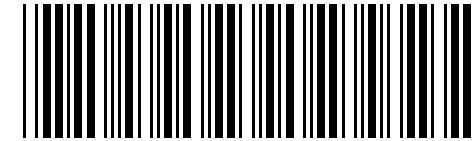

3121217

## JLG Worldwide Locations

JLG Industries (Australia)  
P.O. Box 5119  
11 Bolwarra Road  
Port Macquarie  
N.S.W. 2444  
Australia

☎ +61 2 65 811111

☎ +61 2 65 810122

JLG Latino Americana Ltda.  
Rua Eng. Carlos Stevenson,  
80-Suite 71  
13092-310 Campinas-SP  
Brazil

☎ +55 19 3295 0407

☎ +55 19 3295 1025

JLG Industries (UK) Ltd  
Bentley House  
Bentley Avenue  
Middleton  
Greater Manchester  
M24 2GP - England

☎ +44 (0)161 654 1000

☎ +44 (0)161 654 1001

JLG France SAS  
Z.I. de Baulieu  
47400 Fauillet  
France

☎ +33 (0)5 53 88 31 70

☎ +33 (0)5 53 88 31 79

JLG Deutschland GmbH  
Max-Planck-Str. 21  
D - 27721 Ritterhude - Ihlpohl  
Germany

☎ +49 (0)421 69 350 20

☎ +49 (0)421 69 350 45

JLG Equipment Services Ltd.  
Rm 1107 Landmark North  
39 Lung Sum Avenue  
Sheung Shui N. T.  
Hong Kong

☎ (852) 2639 5783

☎ (852) 2639 5797

JLG Industries (Italia) s.r.l.  
Via Po. 22  
20010 Pregnana Milanese - MI  
Italy

☎ +39 029 359 5210

☎ +39 029 359 5845

Oshkosh-JLG Singapore Technology  
Equipment Pte Ltd  
29 Tuas Ave 4,  
Jurong Industrial Estate  
Singapore, 639379

☎ +65-6591 9030

☎ +65-6591 9031

JLG Polska  
Ul. Krolewska  
00-060 Warszawa  
Poland

☎ +48 (0)914 320 245

☎ +48 (0)914 358 200

JLG Industries (Scotland)  
Wright Business Centre  
1 Lonmay Road  
Queenslie, Glasgow G33 4EL  
Scotland

☎ +44 (0)141 781 6700

☎ +44 (0)141 773 1907

Plataformas Elevadoras  
JLG Iberica, S.L.  
Trapadella, 2  
P.I. Castellbisbal Sur  
08755 Castellbisbal, Barcelona  
Spain

☎ +34 93 772 4700

☎ +34 93 771 1762

JLG Sverige AB  
Enkopingsvagen 150  
Box 704  
SE - 176 27 Jarfalla  
Sweden

☎ +46 (0)850 659 500

☎ +46 (0)850 659 534