



**CONFIDENCE AT ITS HIGHEST LEVEL**

# USER MANUAL

K38P / K42P Model

Type 1B elevator

**ORIGINAL MANUAL**





**Table of contents**

I.	INTRODUCTION .....	5
II.	GENERAL INFORMATION.....	6
A.	Included documentation.....	6
B.	Document data .....	6
C.	Recipient .....	6
D.	Information property .....	6
E.	Specific terms.....	7
F.	General Characteristics .....	8
➤	Size specifications .....	8
G.	Planned and unplanned uses .....	10
➤	Planned uses.....	10
➤	Unplanned uses.....	10
➤	Cases where the manufacturer cannot be held liable.....	10
➤	Load limiter .....	10
➤	Load selector (optional). .....	11
H.	MEPP identification data.....	11
I.	Declaration of compliance .....	12
J.	Warranty.....	13
➤	General terms and conditions .....	13
➤	Request for service under warranty and relative arrangements .....	13
K.	After-sales service .....	14
➤	Request for troubleshooting service.....	14
L.	Use of manual .....	14
III.	SAFETY INFORMATION .....	15
A.	Safety criteria .....	15
B.	Appointed staff aptitude.....	15
C.	Signaling.....	15
D.	General safety prescriptions and provisions .....	16
E.	Before starting to work.....	17
F.	Precautions while working .....	18
G.	Precautions when finishing or interrupting work.....	19
H.	Safety measures during servicing .....	19
IV.	TECHNICAL DESCRIPTION.....	21
A.	Description of elevator parts .....	21
V.	ACTIVATION .....	26
A.	Before use:.....	26



B.	Position and description of the main elements .....	28
C.	Elevator operation .....	32
D.	Stabilization outriggers .....	34
VI.	EMERGENCY MANEUVERING AND PROCEDURES.....	35
A.	Emergency shutdown .....	35
B.	Emergency pump .....	35
C.	Override (optional).....	35
D.	Hydraulic distributors .....	36
E.	Actuator control .....	37
VII.	MAINTENANCE .....	41
A.	Daily inspection .....	42
	Weekly inspection .....	43
	Bimonthly inspection .....	43
	Six monthly inspection.....	43
	Compulsory servicing after one year or 500 hours of use (whichever comes first).....	44
	Hydraulic oils / filters .....	45
	Greasing.....	45
➤	Slew ring.....	45
➤	Shafts .....	45
	Warranty cover .....	46
	Diagnostic .....	46
VIII.	ELIMINATION AND DEMOLITION .....	49
A.	Operator qualification.....	49
	Equipment deactivation .....	49
	Deactivation procedure.....	49
	Remaining risks after deactivation .....	49
IX.	HYDRAULIC AND ELECTRIC DIAGRAMS .....	50
A.	Hydraulic drawings .....	50
B.	Circuit drawings .....	51
A.	Writing instructions .....	52
B.	Delivery of platforms owner .....	52
C.	Successive ownership transfers .....	53
D.	Replacement of parts.....	54
E.	Safety replacement.....	57
F.	Checking / repairs / maintenance .....	59
G.	Notes.....	62



## I. INTRODUCTION

Thank you for choosing **KLUBB**. This elevator has been made to provide its users with the best equipment for work at a height. With the full control panel available in the bucket and the many possible movements of the boom, the product offers flexibility, high performance and especially efficiency at work.

Each user must always remember that this equipment requires regular upkeep that is very important to keep its efficiency, avoid deterioration and increase its life duration.

This manual is designed to give you practical and essential information so that you can use your elevator with optimal efficiency and safety. Using this elevator within the defined limits calls for clear understanding of its capabilities and is the liability of the user. We advise you to read the instructions carefully before you start to use the elevator.

### **WARNING:**

- **THIS MANUAL MUST BE CONSIDERED AS AN INTEGRAL PART OF THE ELEVATOR AND MUST BE AVAILABLE TO THE USER AT ALL TIMES.**
- **READ THIS MANUAL CAREFULLY BEFORE YOU START TO USE THE ELEVATOR.**

With a concern for constant improvement **KLUBB** reserves the right to modify the technical characteristics of its elevators without any obligation to upgrade any products it has already sold.

Your satisfaction is very important to **KLUBB** and special care has been taken to make this manual as complete and user-friendly as possible.



## II. GENERAL INFORMATION

### A. Included documentation

- User manual (this document)
- Circuit and hydraulic diagrams

### B. Document data

Elevator user manual

K38P / K42P Models

Note: Some of the pictures and drawings in this manual may not correspond exactly to the customer equipment. However, they supply all the information needed to allow clear understanding of the instructions.

### C. Recipient

- User
- Technician in charge of servicing

**Question:** Anybody receiving a copy of this manual, especially the technicians assigned to the assembly and disassembly of the equipment, must observe the instructions it contains and in particular not perform any operations stipulated as having to be performed by **KLUBB** or a company certified by it.

### D. Information property

This manual contains information representing reserved property. All rights reserved. These instructions may not be copied fully or partially without the prior written consent of the company. Only the customer who received this manual with the equipment may use it, and exclusively for the use and maintenance of the device it refers to. The company certifies that the information supplied in this manual is consistent with the equipment technical and safety instructions as described in it. The Manufacturer cannot be held liable for any injury to people or animals or any damage to property, direct or indirect, caused by the improper use of the equipment.

The company reserves the right to make unannounced changes or improvements to this manual and to the equipment even for equipment of the same model type as that which the document is designed, but having a different serial number.



## E. Specific terms

**Qualified staff:** Trained persons with required experience and knowledge of the standards and prescriptions relative to all accident prevention measures and service conditions, and who are specifically authorized by the Safety Manager for the performance of any necessary activities and who are capable of detecting and avoiding any possible danger.

**MEPP:** Mobile Elevator Platform for Persons (Vehicle + Lift).

**W.P:** Working Platform (Bucket).

**PTO;** Power Take Off.

**Danger:** Danger indications give warning of procedures that, if not followed, may result in serious injuries or even death, or that may endanger the health of the operator or exposed persons.

## F. General Characteristics

### ➤ Size specifications

#### 1. 14m (K38P) with stabilizers

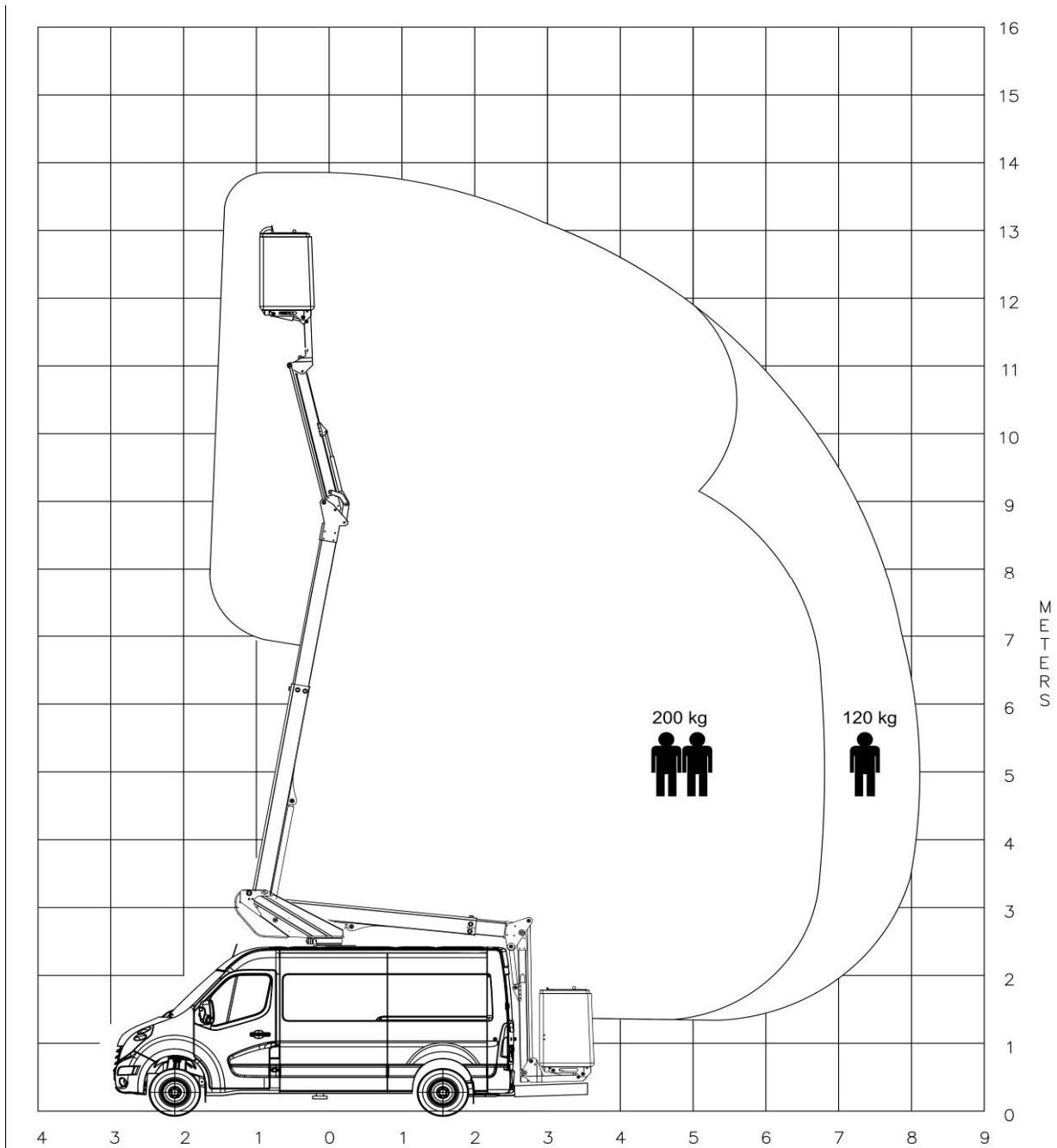

WITH A CONSTANT CONCERN FOR SAFETY AND QUALITY  
THE COMPANY RESERVES THE RIGHT TO CHANGE THESE CHARACTERISTICS





**2. 15m (K42P) with stabilizers**

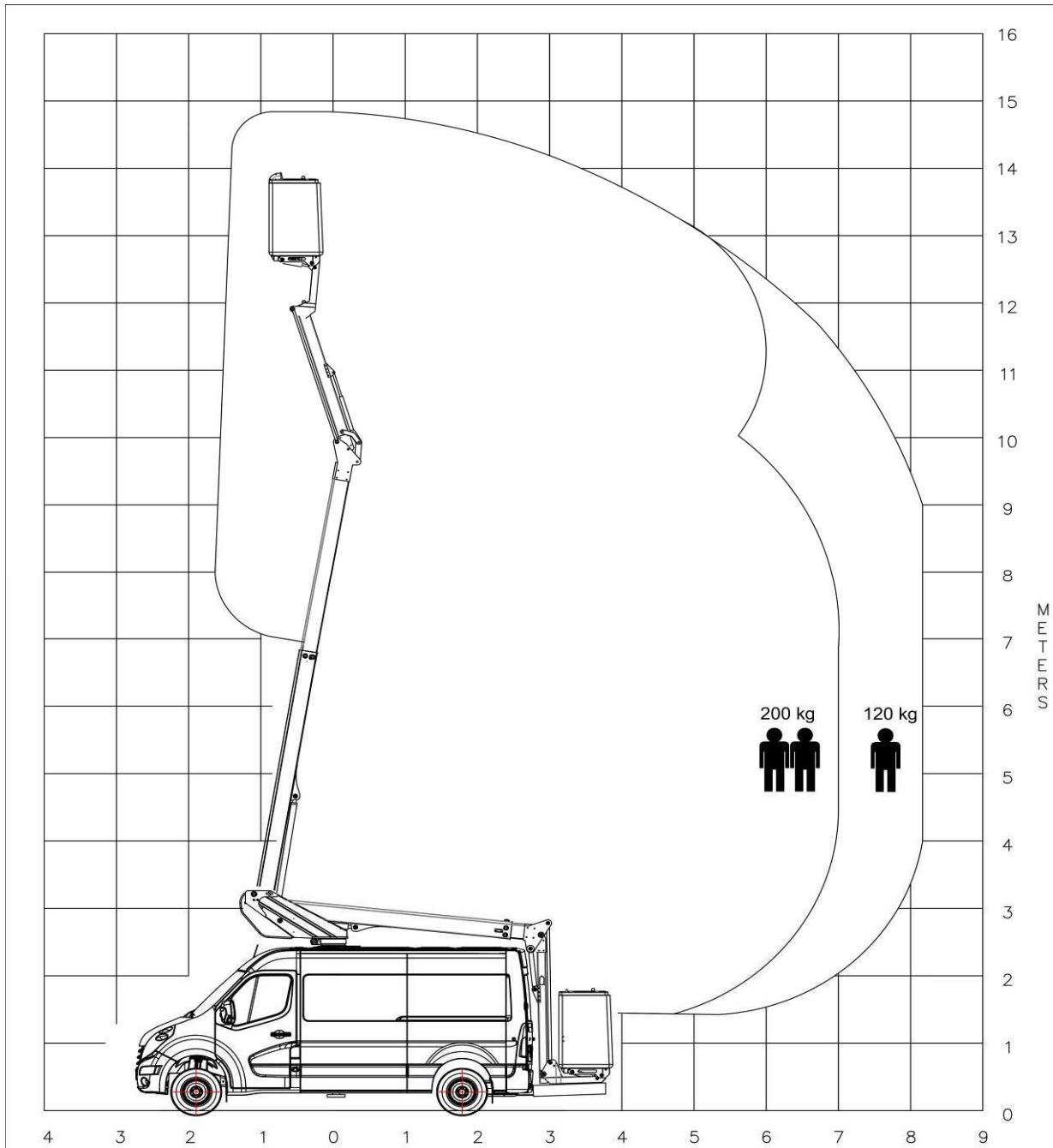

WITH A CONSTANT CONCERN FOR SAFETY AND QUALITY  
THE COMPANY RESERVES THE RIGHT TO CHANGE THESE CHARACTERISTICS



## G. Planned and unplanned uses

### ➤ Planned uses

The MEPP consists of a carrier vehicle and the elevator which is an integral part of this machine. It is designed for lifting people and tools according to indications; the maximum planned work cycle of the MEPP is 100,000 cycles. According to the EN 280 standard, the 100,000 work cycles, if executed on a regular basis for 10 years, should correspond to the following: use of machine for 50 weeks/year, 40 hours per week, 5 cycles per hour.

The machine must be used by suitably trained personnel to guarantee absolute safety and avoid any risks to third parties.

### ➤ Unplanned uses

Any different use, not explicitly covered in paragraph *II.L.1: Planned use*

### ➤ Cases where the manufacturer cannot be held liable

The Manufacturer is not liable in any of the following cases:

- Uses not provided for in this manual.
- Improper use of the machine or use by non-qualified persons.
- Uses not complying with standards.
- Lack of scheduled servicing.
- Unauthorized changes or operations.
- Removal of seals.
- Use of non-original spare parts.
- Failure to comply partly or fully with the instructions.
- Failure to fill in or sign the service sheet (See chapter XI. Inspection register).

### ➤ Load limiter

In standard form, our lifts are not equipped with load limiters, They correspond to the real for stability criteria of standard EN 280. I.e., stability tests with 150% of the nominal load (static) and 110% of the nominal load (dynamic) with a smaller size bucket.

➤ **Load selector (optional).**

Monitoring the loading condition of the bucket is by three indicator lights on the right-hand side of the upper station (see green box).

1. When the load in the bucket corresponds to conditions of use with 1 person, capacity less than 120 kg, the green indicator light (see 1) is on.
2. If the load exceeds this value, it is considered that there is a change to the 2-person mode and an audible alarm sounds for 5 seconds and the yellow indicator light (see 2) comes on and the green indicator light goes out.
3. If the load finally exceeds 200 kg, the light changes over to the red indicator light (see 3) and the supply to the upper station is cut off. Lowering can only be carried out using the lowering remote control, using the override feature.



**H. MEPP identification data**

See the information stamped into the manufacturer nameplate to correctly identify the MEPP. This plate is affixed on the column.

<b>KLUBB</b>		PLAQUE CONSTRUCTEUR BUILDER'S PLATE		<b>CE</b>
Modele de la nacelle / Designation - <i>Lift model</i>		Charge utile max en nacelle (personnes comprises) <i>Max payload inside the lift (people included)</i>		Nb de personne <i>Nb of person</i>
<input type="text" value="KLUBB /"/>		<input type="text"/> kg		<input type="text"/> pers
Numero de serie - <i>Serial number</i>		Hauteur max plancher - <i>Maximum floor height</i>		<input type="text"/> m
<input type="text"/>		Déport max bord panier - <i>Maximum basket edge offset</i>		<input type="text"/> m
Date de construction (MM/AAAA) - <i>Date of building (MM/YYYY)</i>		Inclinaison max du véhicule (Longitudinale / Transversale) <i>Vehicle maximum tilting (Longitudinal / Transversal)</i>		<input type="text"/> % / %
<input type="text"/>		Force horizontale max - <i>Maximum horizontal strength</i>		<input type="text"/> N
Puissance nominale - <i>Nominal power</i>		Vitesse max du vent - <i>Maximum wind speed</i>		<input type="text"/> m/s
<input type="text"/> kW		<input type="text"/>		
Masse du véhicule équipé - <i>Weight of equiped vehicle</i>				
<input type="text"/> kg				
KLUBB 12, avenue James de Rothschild 77164 Ferrières-en-Brie				



## I. Declaration of compliance

There follows a specimen of the CE compliance declaration:

### CE compliance declaration relating to machines

#### Manufacturer

Company; **KLUBB**  
 Address; 12, av. James de Rothschild 77164 Ferrières en Brie, France  
 Telephone; +33 (0)1 60 95 12 47  
 Fax; +33 (0)1 60 05 68 38

#### Product identification

Description; Mobile Elevator platform for persons (MEPP) type 1 B  
 Type; **KLUBB K32**  
 MEPP Serial Number: 150001  
 Vehicle; Renault Master L2H2  
 Vehicle Serial Number; VF6MFFESC53485528

#### Technical datasheet

Without prejudice to its intellectual property rights, the request for information duly motivated on the technical report is possible by letter to the following address:

Address : KLUBB - 12, av. James de Rothschild 77164 Ferrières en Brie, France

**Conformity** This product was designed, manufactured and validated in compliance with the Machines Directive of 17 May 2006 (2006/42/CE), the directive relating to *electromagnetic compatibility* of 15 December 2004 (2004/108/CE) and the directive relating to *noise emission into the environment by equipment used in open air* of 8 May 2000 (2000/14/CE).

The assembly of the top structure of the MEPP and installation on the vehicle were carried out in compliance with the methods defined by the manufacturer and the camber specifications given by the vehicle maker.

The results of all manufacturing inspections, examinations and qualification tests are registered in accordance to the manufacturer quality process.

No modification to the control units, the safety components or options concerning safety of the elevator will be authorized without explicit agreement by KLUBB.

#### CE Type review

This acceptance by type has been approved by the following notified organization:

Name; APAVE Parisienne SAS  
 Identification number; 0060  
 Address; 17 rue Salneuve – 75854 Paris CEDEX  
 CE type certificate No.; 0060/ 5536 / 760 / 11/15 / 0001

**Harmonized standards** Design, manufacturing, installation, protection and tests of the MEPP have been performed in compliance with European, international and national standards. The most important are mentioned on the following list:

- EN 280 MEPP – Design calculation – Stability criteria – Building – Security – Tests and reviews
- EN 349 Machines safety – Minimum distance to avoid risks of crushing human body parts
- EN 13849-1 Machine safety - Parts of control systems relative to safety - Part 1: general design principles
- EN 13849-2 Machine safety – Parts of control systems relative to safety - Part 2: validation
- EN 60204-1 Machine safety – Machine electrical equipment - Part 1: General rules
- ISO 20381 Mobile personnel elevators – Symbols used for operator controls and other indicators

**Declaration location:** Ferrières en Brie, France **Date;** 23/11/2015

Person authorized person to write this statement.

**Name:** Julien Bourrellis **Position;** CEO

**Signature:**



## **J. Warranty**

### **➤ General terms and conditions**

Warranty terms and conditions are specified in the following:

The company guarantees its equipment and undertakes to replace, free of charge and as quickly as possible any faulty part (manufacturing and material defects) for a period of 12 months starting from the date of delivery. Any action under warranty can be made only at the manufacturer's factory provided that the customer is up to date in its payments. The delivery of the equipment to be repaired and its collection are at the expense of the customer.

The above warranty will be void if the customer does not submit the equipment to be repaired within 30 days from the date of his claim which must be supplied in written form. Except in case of fraud or major cases of negligence, the company cannot be held responsible with respect to the customer for any damages concerning defects/damage to the sold equipment.

The guarantee is no longer applicable if the Customer makes changes to the equipment without the prior and written agreement of the company and/or if the equipment is not used correctly and suitably. Concerning the equipment and/or the vehicles used and built by the company, the warranty covering any defect/damage is limited to a term of 30 days from the date of delivery. In any case, any the defects/damage found in the term mentioned above shall be brought to the attention of the Seller within 8 days from their discovery; otherwise the warranty becomes void.

The material warranty is valid only if the inspection instructions and servicing described in this manual are complied with.

### **➤ Request for service under warranty and relative arrangements**

Spare parts orders or requests for troubleshooting under warranty must be sent to the company as soon as a defect is detected, included within the planned conditions. Always specify the type and serial number of the machine when ordering spare parts or requesting troubleshooting under warranty. This information is stamped into the equipment nameplate.



## K. After-sales service

For the optimal use of the equipment and for the servicing operations, this manual cannot replace the experience of the after sales service.

### ➤ Request for troubleshooting service

To contact our specialized technical staff, the Customer may contact the after sales service directly.

## L. Use of manual

Keep this manual in a place that is accessible and known to all users (operators and staff assigned to servicing)

It is very important to read this manual in full before using the MEPP. For use on any operation, for servicing or for elimination, see the corresponding chapter.

Looking for	Consulting
Instructions, advice and safety procedures.	<i>Chapter II: General Information Chapter III: Safety Information</i>
Identification and description of machine.	<i>Chapter II: General Information Chapter IV: Technical description</i>
After sales service, ordering spare parts.	<i>Chapter II: General Information</i>
Use of machine.	<i>Chapter V: Commissioning Chapter VI: Maneuvering and emergency procedures</i>
Prevention and servicing	<i>Chapter VII: Maintenance</i>
Final elimination or demolition	<i>Chapter VIII: Elimination and demolition</i>

**Question:** For other information about the truck, see the appropriate instructions and maintenance details.

This manual must be kept in a protected place in the driving cab of the vehicle so that it can be found easily if needed for consultation during the entire lifespan of the equipment.

If you lose or damage the manual, ask the manufacturer for a new copy, specifying the serial number of the equipment to be found on the specific nameplate. The Manufacturer is committed to supplying you with a new copy.

If the used equipment is sold, also hand over this manual and the relative attachments; also informed the Manufacturer of the name of the new owner (see para. IX.C: Successive transfer of ownership).



### **III. SAFETY INFORMATION**

#### **A. Safety criteria**

During the design and manufacture of this machine, the criteria and expedients aimed at fulfilling essential safety features provided for by the law were put into application, in particular:

In France:

- 2006/42/CE directive
- EN 280 Design calculations - Stability criteria - Engineering - Safety, testing and trials

#### **B. Appointed staff aptitude**

The operators appointed to the use of the elevator must be suitably trained, informed and skilled in using the machine safely and must have a suitable training certificate. Operators must be adults and considered as capable of performing these operations from the psychophysical standpoint.

In particular, the following requirements should be verified:

- Good eyesight and hearing,
- Not under the effect of the use of drugs or alcohol,
- Psychologically balanced with no evidence of depression or stress

The operators must be familiar with the legislation regarding the moment of the machine on the road and its use. In addition, they must hold a driver's license corresponding to the task.

Klubb cannot be held liable for any injury to person or damage to objects or for any other damages resulting from:

- Failing to comply with safety instructions.
- The machine being used by unqualified operators,
- Failing to comply with the recommendations made in the supplied documentation.

It is highly advisable for the user to have a CACES certificate.

In addition, the user must have been familiarized on this equipment, specifically by the manufacturer. When a new user is required, contact us immediately so that we can familiarize him with the equipment.

#### **C. Signaling**

The following plates are applied to the equipment:

- Identification (see Fig. 1-1- Identification plate)
- Instructions
- Obligations/Interdictions
- Caution
- Danger





**Caution:** Always observe safety instructions given on these plates. Any failure to comply with these instructions could lead to serious injuries, or even death, or in any case a danger to exposed operators and/or people. Always check that the plates are properly applied and legible. If not, apply them or replace them.

## D. General safety prescriptions and provisions

**Respecting safety instructions** and using safety devices properly enables operators to work productively and safely, not only for themselves but also for others.

**Check the trouble-free operation of the installations and protection and safety equipment.** Immediately report any malfunction to the person in charge in order to be able to perform the servicing needed to reestablish original safety and reliability conditions.

**It is prohibited to deactivate or modify any type of safety or protection equipment** In such cases, the warranty is voided and the company is relieved of any liability.

**Danger:** It is absolutely prohibited to disconnect any of the machine safety devices.

**Danger:** It is absolutely prohibited to use the machine when the safety devices are not activated.

According to the standards providing protection against accidents, when he is on the platform, **the operator must:**

- **wear a helmet**
- **wear and attach the safety harness** to the fixed ring in the bucket
- The operator on the ground must also wear a helmet.

Also wear suitable protective clothes of an approved type (nonskid safety shoes, vest with reflecting stripes ...). Further, the operators must not wear rings, watches, jewels, open or loose fitting clothes such as ties, torn clothing, scarves, unbuttoned jackets or unzipped shirts which could catch on the moving gears.

Always keep the operator compartment, the surfaces, the steps of the stairs, the handrails and the large supporting handles clean and free without there being any objects or marks left by oil, mud or snow, to minimize any risks of sliding or tripping.

Always use stepladders, ladders, handles and dedicated handrails and never use the controls and the flexible pipes as supports.

Clean the soles of your shoes before entering the MEPP.

Make sure that all the shelters and protections are correctly placed and that all the safety devices are in place and operate efficiently.

Before use, it is essential to check the performance of the machine and its components. The MEPP must be cared for and be in perfect condition according to the servicing program. Report any operational irregularities to the servicing operators.

Many parts of the machines are made of special highly elastic steel: never weld the machine without first obtaining the written authorization and instructions from **KLUBB**.





The machine must never be maneuvered by anybody without the necessary skill and familiarity as it would compromise the safety of the user and of other people.

**In any case**, every user or driver of the machine **must conform to the applicable Highway code** in the country where he is located.

Read this manual carefully before carrying out startup, use and servicing operations, and any other work on the machine.

The maximum noise level measured during the use of the MEPP is **90dB**. If necessary, wear suitable ear defenders.

This device is designed for **outdoor use**. If it is to be used indoors, as an exception, it is essential for the premises to be properly ventilated.

It is **FORBIDDEN** to use the MEPP during stormy weather.

## E. Before starting to work

Before starting the engine of the vehicle, always disconnect the Power Take Off (P.T.O).

Before driving off, check that the machine is in the operating position.

Always perform the specified daily checks.

Always ensure that the MEPP is level before beginning the work, by choosing the correct area where the installation is to be positioned, ensuring that the surface is level, compact and stable. Comply with the maximum inclination angles specified on the manufacturer's nameplate.

For vehicles equipped outriggers (option):

- 1: Apply the vehicle handbrake.
- 2: Pull the outriggers out, avoiding such items as manholes, drain networks or any similar systems (unless double acceptance by APAVE is carried out).

**Danger:** Always take care not to lower the outriggers on your feet or those of 1/3 party. There is a risk of serious injury.

For vehicles without outriggers:

- 1: Apply the vehicle handbrake.
- 2: Install the wheel chocks.

If the MEPP is required to work on the road, or if visibility is diminished, it is compulsory to signal its presence by signs bearing diagonal red and white stripes, constantly lighting the flashers on the cab of the truck (emergency warning lights, triple flashlight etc.).



## F. Precautions while working

**Always make sure** that no persons (or animals) are standing in the operating area of the MEPP. In general, avoid contact with permanent obstacles (constructions etc.) or removing obstacles (vehicles, lifting equipment, etc.).

**It is prohibited** to place ladders or any other device inside the platform increase the working height, or any other element that could increase the effect of the wind.

**It is prohibited** to work near overhead high-voltage electricity lines and in all cases, the platform must be at a minimum safety distance of 5 m from the cables.

**It is prohibited** to move the vehicle when the operator is on the platform (Type 1B elevator).

**It is prohibited** to use the MEPP as a crane.

**It is prohibited** to overload the MEPP (refer to the manufacturer nameplate to check the permissible maximum load of the platform).

**It is prohibited** to move the vehicle if the MEPP is not fully folded.

**Avoid allowing** any object or device to fall from the platform.

**It is prohibited** to get in or out the platform during overhead work.

**It is prohibited** to lean the platform on any other fixed or mobile structures.

**It is prohibited** to use the MEPP if the wind speed exceeds the values specified on the manufacturer nameplate.

**Do not use** the MEPP except within the permitted temperature range (-15°C to +50°C).

**Do not use** the MEPP if the visibility is insufficient.

**It is prohibited** to stay on the vehicle bed when the platform is being maneuvered.

**It is prohibited** to affix signs or banners to the elevator MEPP.

**All the movements** required to reach the desired service area must be carried out by the operator on the platform (P.T.). Maneuvering on the ground is only allowed in emergencies.

**When using the MEPP** in an emergency on the ground, the operator is inside the working zone of the MEPP, therefore incurring a **risk of being crushed** in case of an erroneous maneuver. Carry out all movements as slowly and carefully as possible.

### **In case of oil leakage from the hydraulic system:**

**Danger:** Do not move too close to the flow of oil because it is at high pressure in the hydraulic systems and splashing is liable to cause injury.

1 : Press the emergency shutdown button

2 : Disconnect the Power Take Off (P.T.O)

**It is prohibited** to use the platform if the mobile access protection (small gate) is lifted, or to stop it with the platform lifted.

**It is prohibited** to load/unload any object on the platform during overhead work. In the event of danger, press the emergency shutdown button.



**Do not press the bucket** of the MEPP platform on the ground.

**Do not use the MEPP** unless it complies with the permitted tilt angle as specified on the manufacturer nameplate.

**Ensure that the boom does not get in the way** of the vehicle cab and/or with other parts of the elevator.

**It is prohibited** to overload the MEPP. The lifting capacity of the MEPP corresponds to the service load for which it was designed and includes the weight of the operators and tools needed for the specified activities.

**Never insert** your body, appendages or fingers in the articulated openings which are sharp cutting and pointed in certain parts of the machines, unless they have been checked and without suitable protection, unless everything is very securely locked.

**Danger** When the machine is level, the following are **absolutely prohibited**

- 1 : Releasing the parking brake
- 2 : Engaging a gear

This prohibition is necessary to eliminate any risk of engaging a gear which could cause abnormal and uncontrolled performance of the structure, in particular if the boom is not as rest, possibly causing severe damage to the machine and injury to people located within the working zone of the platform.

To prevent any movement of the vehicle when there is an operator in a bucket or if the elevator has not been entirely folded away in the road running position, a **motor cutoff system** has been installed. Furthermore, **it is compulsory to use the wheel chocks** supplied to prevent any movement of the vehicle if it is parked on slope.

## G. Precautions when finishing or interrupting work

If possible, **take care** when pulling the outriggers up (option).

**It is prohibited** to leave the MEPP unattended and without ensuring that the motor is off, the parking brake engaged, the control panels blocked and the platform out of reach.

## H. Safety measures during servicing

**Any servicing not included in this manual** must be carried out only by people authorized by the company. Grease the MEPP while using suitable needs to guarantee absolute safety.

**No servicing operation** master be started until the emergency shutdown button has been pressed and the motor brought to a stop. The elevator must also be at rest during servicing (folded away or resting on a support).

**Think about the environment:** Prevent any oil from flowing out during filling or oil changing. Eliminate spent oil according to the applicable standards.



**Never insert** your body, appendages or fingers into articulated, sharp cutting and pointed openings of machine parts unless all the safety precautions have been implemented (complete shutdown, locking of machine movements ...)

When using the machine from a low position (emergencies only), with the operator on the platform, there is a constant **risk of crushing** in the event of a wrong maneuver. **Carry out all movements as slowly and carefully as possible.**

**Never use petrol or solvents** or other flammable liquids to replace detergent; preferred the use of authorized nonflammable and non-toxic off-the-shelf products.

**While using compressed air** to clean the parts, always wear safety glasses with lateral protections keep air pressure to a maximum of 2 atm (1.9bar) maximum.

**Never use bare flames** as a means of lighting during maintenance operations.

**Ensure that** all elements of the hydraulic system are safely closed.

**Before disassembling any part of the hydraulic system,** ensure that there is no oil or other liquid under pressure that could escape and cause serious injury. In the event of accidental injury or absorption, contact a doctor immediately. Oil projections can be almost invisible and be strong enough to penetrate through the skin. **Never disassemble with your hands.** In the event of the liquid coming into contact with the skin, contact a doctor immediately; the lack of first-aid can lead to serious infections and skin ailments.

KLUBB CANNOT BE HELD LIABLE FOR ANY ACCIDENTS OR FAILURE DUE TO FAILURE TO COMPLY WITH THE SAFETY WARNINGS AND INSTRUCTIONS.

#### IV. TECHNICAL DESCRIPTION

##### A. Description of elevator parts

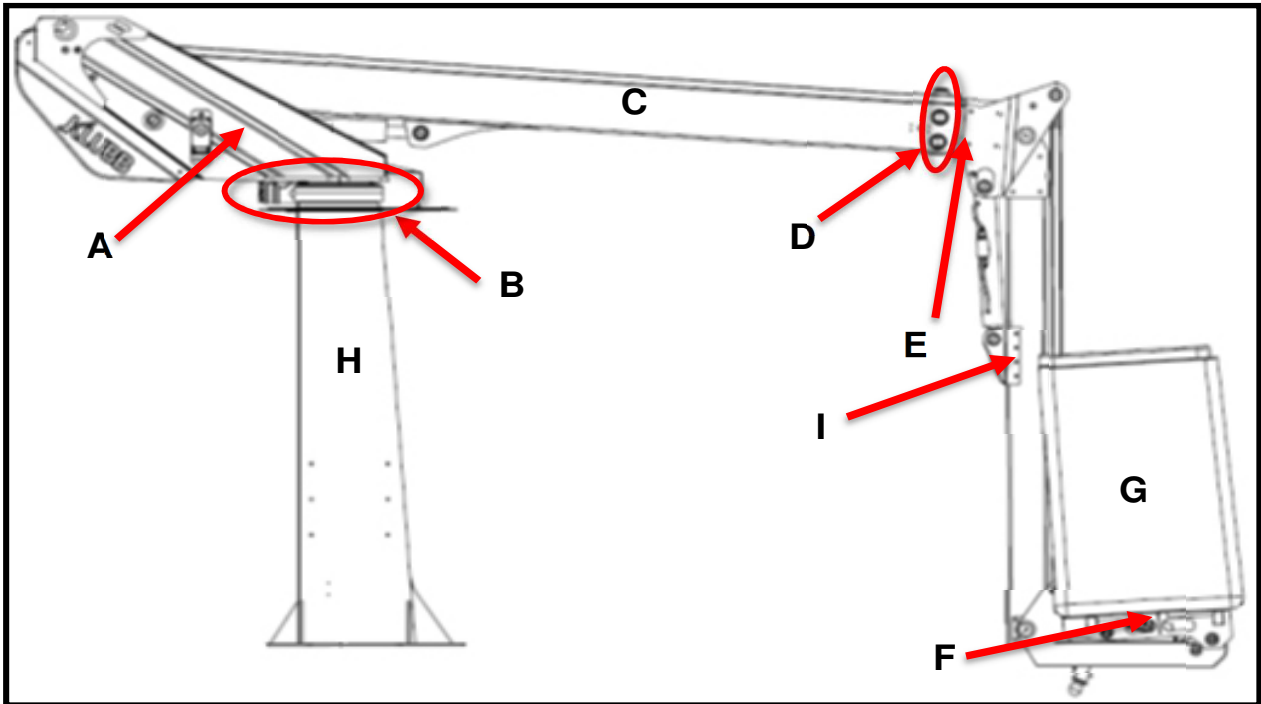

Index	Part
A	Turret
B	Hydraulic rotation motor
C	Main boom
D	Teflon bearings
E	Telescopic boom
F	Bucket holder
G	Bucket (1 or 2 persons)
H	Column
I	Boom / Pendular flyboom

## **BUCKET**

Fiberglass bucket, opening on sidewalk side / Aluminum bucket, opening on sidewalk side



## **HYDRAULIC LEVELING**

Automatic leveling bucket with master/slave hydraulic outriggers. Leveling can be manually controlled from the top or bottom control panels.

## **SAFETY HOOK**



There is a safety ring installed inside the elevator for attaching to the operator's safety harness.

## **TELESCOPIC BOOM**



Made of a tubular steel articulated on the turret and of an aluminum telescopic mast sliding on PTFE bearings.

All movements (up/down, extend/retract) are controlled by two double acting hydraulic outriggers provided with safety valves.

## **PENDULAR BOOM**



The pendular boom consists of an aluminum body reinforced by a steel boom. It hinges on self lubricating bearing shafts and is controlled by a dedicated hydraulic actuator.

It extends the telescopic boom in order to get to the out of reach zones with a fixed fly Bloom.





Rotation is made by a reducer mechanism drives by a hydraulic motor.

### **COLUMN**



The column is made of a tubular base with an oil tank and a deck assembled to the floor of the vehicle. Fastening is ensured by bolting directly around the cross members of the chassis frame.

The inside of the column receives the emergency electric pump and safety devices.

On the outside, the electrical main box, the time meter and the emergency control panel are installed.

### **TURRET**

360° non-continuous rotation The turret receives the hydraulic distributor and the rotation mechanism.

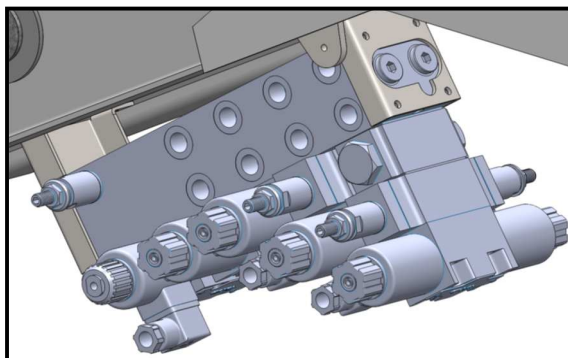

### **MAIN HYDRAULIC SYSTEM**

The main hydraulic power system is powered by a gear-type oil pump driven by a power take off mounted on the gearbox of the vehicle.

The pressure flow torque is 11 L/mn / 150 bars produced by the engine of the vehicle running at idle.

**AUXILIARY HYDRAULIC POWER SYSTEM**

The auxiliary hydraulic power system is powered by an electric oil pump powered by the vehicle battery.

**CONTROL PANELS**

In order to the need for multiple hydraulic pipes in the boom, controls from the cradle are electric: they consist of a series of joysticks and pushbuttons, grouped together and mounted on a control station attached to the cradle. The control station allows the use of the emergency circuit.



The emergency shutdown and engine starting controls are grouped together on this panel. The emergency controls on the ground take priority and are available through a remote control.

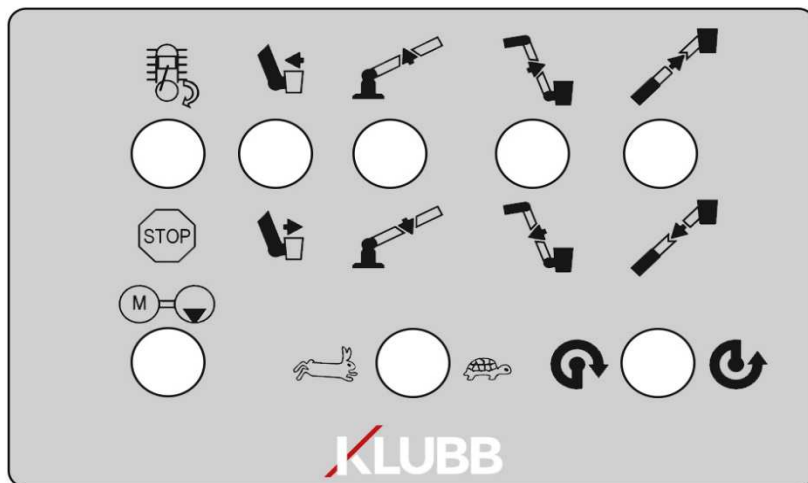
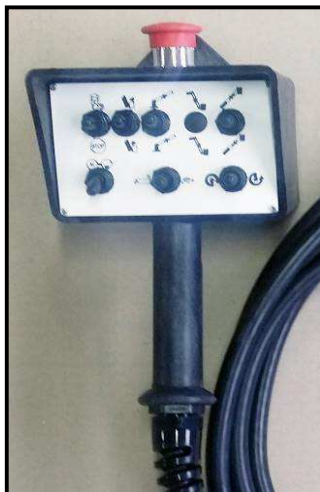





## SAFETY DEVICES

- Internal leaks are handled by controlled nonreturn valves which block the actuators in the event of the hydraulic system failing.
- The rotation torque is limited by a pressure limiter. A reducer (worm screw) of the self locking type prevents any racing in rotation.
- A pressure limit or shared by the various circuits maintains the service pressure at the recommended level in all cases.
- Manual control on the turret in case of system failure.
- Emergency power system supplied by an electric oil pump the top and bottom stations.
- Overriding of emergency shutdown or limitations from the bottom control station.
- Automatic return of control levers to the neutral position.
- Ring for safety harness in the bucket.
- Parking brake security system.



## V. ACTIVATION

Refer to the chapters entitled *SAFETY INFORMATION (chapter III)* and *TECHNICAL DESCRIPTION (chapter IV)*, before commissioning the cradle elevator.

Check that the safety labels are visible:

**DO NOT USE THIS ELEVATOR WITHOUT REQUIRED QUALIFICATION AND EXPERIENCE;**

**AN UNSKILLED OPERATOR COULD CAUSE SERIOUS INJURIES TO HIMSELF AND CLOSE PEOPLE**

### A. Before use:

Always Check:

- Oil level, water level, battery
- Tire pressure
- Warning lights
- Parking brake
- Emergency power system operation
- Revolving light, Triflash light operation

### VEHICLE TRAVELING:

- When the vehicle or carrying of the elevator is traveling, the boom must be placed in the support designed for the purpose.

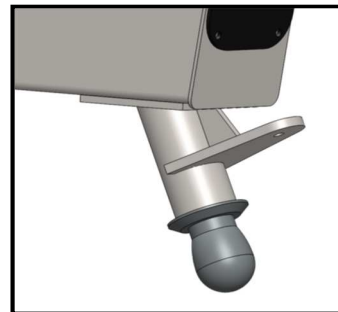

- Make sure the power take off is disengaged
- Check that the “Travel forbidden” red indicator light inside the cabin is off.

If it is lighted, there are several possibilities:

- Power take off is engaged
- The elevator is not fully folded into the traveling position.
- The hydraulic outriggers (option) are not fully retracted.





### **POSITIONING FOR WORK:**

The vehicle must be parked on a hard ground to guarantee stability, with large seasonal and transversal tilting complying with the maximum values given on the manufacturer nameplate.

If the elevator is equipped with hydraulic outriggers, avoid setting them down on the loose ground. This type of ground could move or collapse under the weight of the vehicle, at any time. In addition, during stabilization, it is essential not to lift the vehicle axles so that the wheels are always kept in contact with the ground or with the weight distribution chocks.

Keep the working space on the bed of the vehicle clean and clear.

Never work with any part of the elevator (bucket, boom, outriggers etc.) in an area that is not marked out. Use devices like cones or barriers to one drivers and pedestrians about your working space.

When using the MEPP, the bearing force induced by the wheels or outriggers (optional) is 15 kN.

### **POINTS TO COMPLY WITH BEFORE USE:**

Before using the elevator, check for oil leakages from the hydraulic power system: Oil spilled beneath the vehicle, on the floor or on the elevator boom.

With the vehicle suitably parked on the work site and before using the elevator.

If the elevator has not been used for a long time or if it has been recently serviced, put it through the various possible movements using the bottom remote control. This procedure will remove any pockets of air in the hydraulic system that could cause abrupt and unexpected movements.

The user MUST:

- Apply the parking brake
- Move the gear shift lever to neutral.
- Leave of the ignition turned on with the engine idling.
- Engage the power take off
- Turn on the lighted signaling ("Triflash" button and "Gyro" (revolving light) button).
- Mark out the working area
- Chock the wheels with the supplied chocks.
- Lock the cab doors of the vehicle.

### **ACCESS POSITION**

The platform must only be accessed when the MEPP is totally folded away in the traveling position (refer to the chapter on vehicle traveling).



## B. Position and description of the main elements

Elevator on van-body vehicle





Index	Function	
<b>A</b>	<b>Bottom remote control</b> (See bottom remote control part below)	
<b>B</b>	<b>Up or down control selection</b> To change from the bottom control station to the top control station, use the key switch on the side of the electric cabinet.	
<b>C</b>	<b>Hour meter</b> Number of operating hours of the machine (1 hour = 50 km)	
<b>D</b>	<b>Upper control panel (bucket)</b> (See upper remote control part below)	
	<b>D1</b>	<b>Movements joystick</b> These joysticks control the up and down movement of the elevator, the rotation and all the movements of the main, telescopic and fly booms. They may also control the hydraulic outriggers (optional). First, select the movement using the joystick and then push the green button at the same time.
<b>E</b>	<b>Controls and warning lights on control panel</b>	
	<b>E1</b>	<b>Power/bucket take off switch</b> This switch is used for engaging the power take off which powers the elevator.
	<b>E2</b>	<b>Revolving light button</b> This button operates the various flash lights. The flash lights work even if the elevator button or the ignition are not engaged and even if the ignition is not on.
	<b>E3</b>	<b>Red prohibited traveling indicator lights</b> When this indicator light is on it means that one of the outriggers is not in the traveling position or that the power takeoff is still engaged. <b>It is then prohibited to move off in the vehicle</b>



Downer remote control

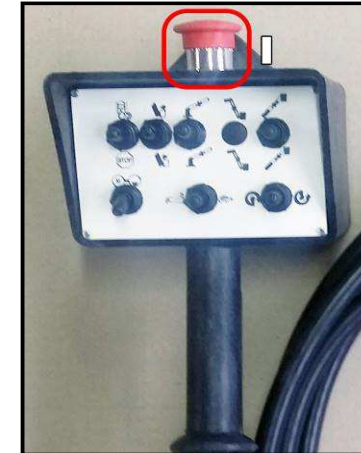
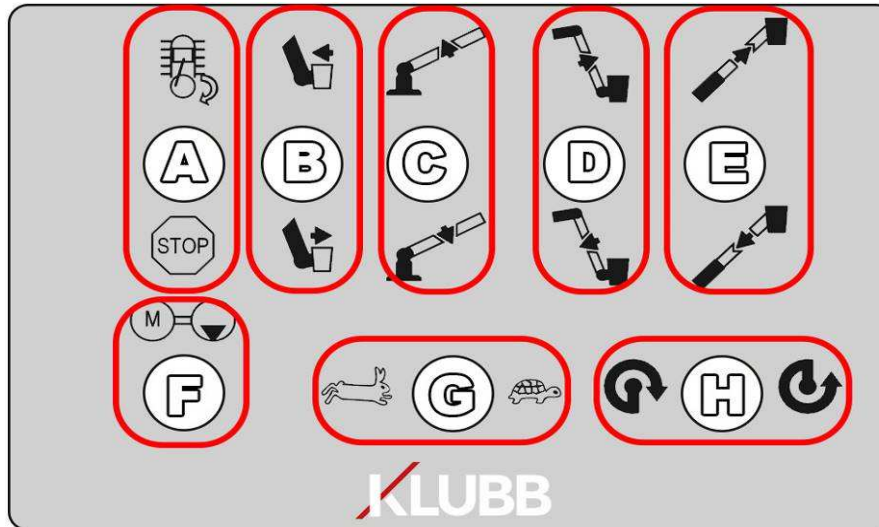

<b>A</b>	Carrier engine start/stop control
<b>B</b>	Working platform leveling
<b>C</b>	Main boom control
<b>D</b>	Extension/retraction of the fly boom (pendular boom)
<b>E</b>	Extension/retraction of the telescopic boom

<b>F</b>	Emergency pump: Holding the buttons down then moving them allows maneuvering running on the vehicle batteries. <b>Never use for more than 30 seconds continuously.</b>
<b>G</b>	Speed of movement: Choose the movement then engage the required speed.
<b>H</b>	Turret rotation
<b>I</b>	Emergency shutdown (on the remote box): Push the button for immediate shutdown of all controls. Turn clockwise to reactivate.



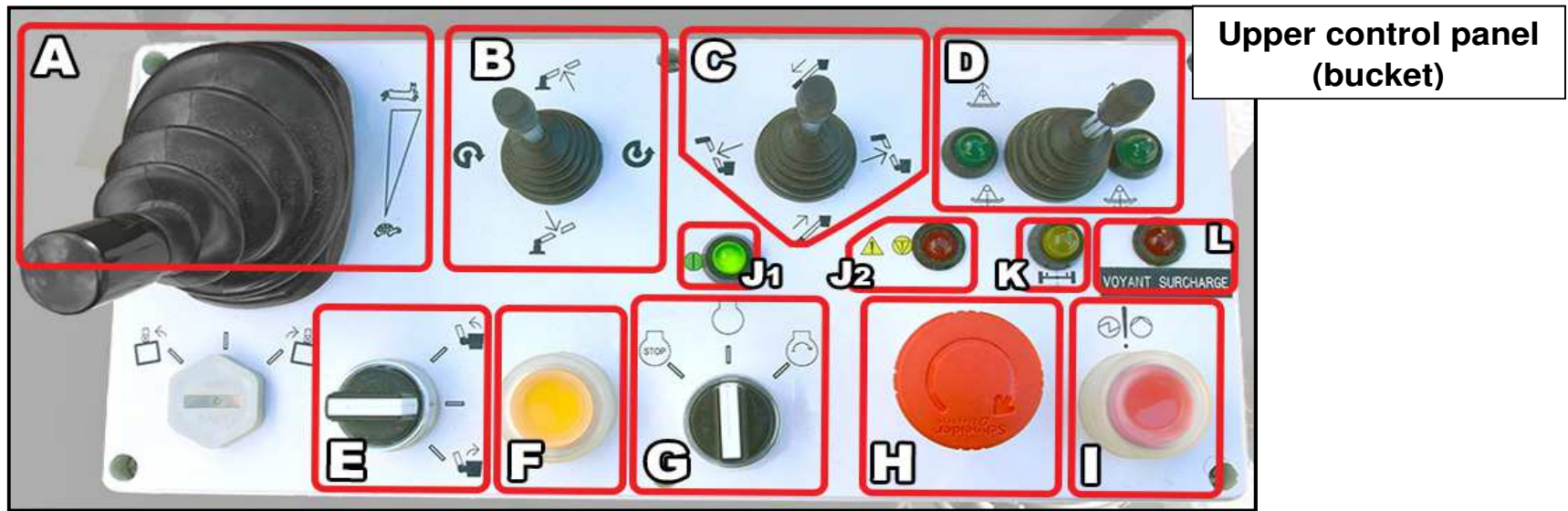

Upper control panel (bucket)

A	<b>Speed selector:</b> This control sets the speed of all the elevator movements. <b>Select the movement first, then the speed</b> <b>To stop, release the speed lever, then the movement joystick.</b>
B	<b>Up/Down:</b> Up/Down movement of the main boom. <b>Left/Right:</b> Turret rotation.
C	<b>Up/Down:</b> Extension/Retraction of the telescopic boom <b>Left/Right:</b> Extension/retraction of fly boom (pendular boom)
D	<b>Left/right up:</b> Outrigger retraction <b>Left/right down:</b> Outrigger extension
E	Working platform tilting (bucket)
F	<b>Outrigger validation:</b> Hold down while maneuvering the outriggers

G	Elevator vehicle engine start/stop control
H	<b>Emergency shutdown:</b> Emergency shutdown (turn to reset)
I	<b>Emergency pump:</b> Hold the movement with this button. Allows maneuvering running on vehicle batteries. <b>WARNING: The emergency pump must never be used more than 30 seconds continuously.</b>
J	<b>J1 (green):</b> Correct operation indicator light <b>J2 (red):</b> Fault indicator light (barrier open, etc.)
K	Outrigger extension indicator
L	Overload indicator



## C. Elevator operation

Now that you are familiar with the various controls of the **KLUBB** bucket elevator, here is the procedure to apply in using your tool:

### USING THE ELEVATOR FROM THE TOP STATION (BUCKET):

- Park on firm and stable ground with wheels pointing straight ahead
- Engage the parking brake to the maximum
- Put the gear shift in the neutral position
- Leave the ignition switch on, **engine running at idle**
- Declutch, engage the power take off, Engage the clutch
- Turn on the signal lights ("GYROS" and "TRIFLASH" buttons)
- Lock the cab doors of the vehicle.
- Mark out the working area (cones, AK5 panels etc.)
- Chock the rear wheels.
- Select the upper control panel using the switch on the main electric box.
- Open the bar, climb into the platform using the step at the rear of the vehicle on the right, close the bar.

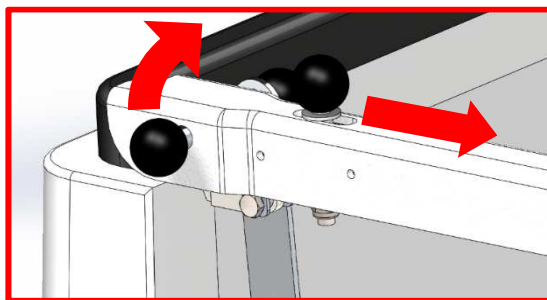

1. Pull the latch
2. Pull up the handle
3. Enter the bucket
4. Close the gate bar, the latch must lock

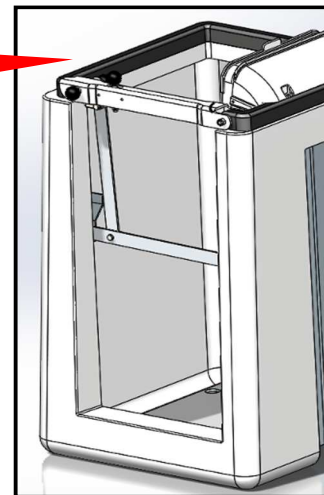

- Secure the safety harness to the hook provided for the purpose



**NEVER HOOK UP MORE THAN ONE PERSON TO A RING**

- Use the hydraulic outriggers for stabilisation (optional). (See "D. Outriggers").





**BEFORE USING THE OUTRIGGERS** always check the area where they will be set (choose a firm and stable ground, avoid manholes, make sure not to crush anybody's feet), use spreader plates.

- Actuate the elevator boom lifting control (**it must always be the first maneuver carried out with the elevator**) to remove the boom from the base (at low speed and to a minimum elevation of 0.5m).

*Once all these steps have been taken, you can carry out the movements needed for the work to be done while keeping at a safe distance from electricity lines and any obstacles around you.*

- Before lowering the main boom onto its support, you must check that:
  - The telescopic boom is fully retracted.
  - The pendular boom is retracted as far as possible.
  - The platform is exactly horizontal.
  - The boom is in line with the vehicle.
- **For a carrier chassis:** Use the two triangular marks, one on the column and the other on the turret, for alignment. These two marks must be properly aligned.

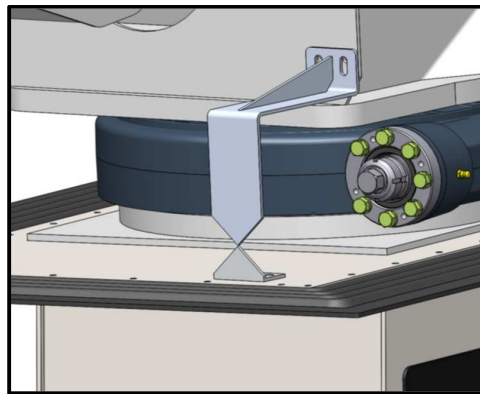

- Once these points have been checked, you can lower the main boom until it abuts. (If the two triangles are properly aligned, there is no need to look at the receptacle at the bottom of the platform).

### **USING THE ELEVATOR FROM THE GROUND:**

- The necessary procedure is the same as the one used for use from the upper control panel except that instead of selecting the upper control panel you must select the bottom remote control panel using the key switch on the main electric box.
- the bottom remote control panel is mounted to the column.

## D. Stabilization outriggers



2 outriggers on either side of the vehicle, level with the column, increase the stability of the carrier.

The outriggers are controlled from the platform control station.

The green indicator lights either side of the control joystick come on when the corresponding outrigger is extended sufficiently. It must then not be extended any further in any circumstances.

**In no case must the wheels of the carrier vehicle lift off the ground**



Under the control joystick, a yellow indicator light indicates when at least one of the outriggers is not totally withdrawn.

On the fly boom, directly facing the operator, there is a spirit level. Operate the outriggers so that the bubble is as close as possible to the 0° mark.





## VI. EMERGENCY MANEUVERING AND PROCEDURES

Emergency procedures may be necessary in the event of the operator becoming incapacitated or the equipment malfunctioning.

This chapter is designed to help operators in emergency control operations and procedures.

**IN AN EMERGENCY, PRIORITY ALWAYS GOES TO PERSONAL SAFETY.**

**BEFORE ANY EMERGENCY ACTION, CHECK THAT THE ELEVATOR IS NOT CONNECTED TO ANY ENERGIZED EQUIPMENT. TOUCHING AN ENERGIZED VEHICLE FROM THE GROUND CAN CAUSE SERIOUS INJURIES OR DEATH.**

### A. Emergency shutdown

Red “emergency” type button on the control panel in the bucket and on the bottom control panel.

#### TO ACTIVATE THE EMERGENCY SHUTDOWN, PUSH THE BUTTON



This will immediately stop the engine of the vehicle and all the functions of the elevator. To use the elevator again, turn the shutdown button counterclockwise to reactivate the machine.

### B. Emergency pump

In the event of the main source of energy (vehicle engine) failing, an emergency pump (electric pump powered by the vehicle batteries) is provided.



To activate this device, hold the movement control down then press the emergency pump button.

- **Only use the emergency pump if the vehicle engine is off.**
- **This device must never be used continuously for more than 30s.**

The emergency pump can be activated from the top station or the bottom station. When the emergency pump is activated, there is no need to use the speed selected.

### C. Override (optional)

In an emergency, pressing the emergency shutdown and movement safety limit controls can be dispensed with to bring up the elevator back down.



- Overriding the emergency shutdown: Hold the button to the right
- Overriding the limitations: Hold the button to the left

Then use the movement controls normally to bring the elevator back into the traveling position.

**IMPORTANT; OVERRIDING MUST BE USED ONLY IN EMERGENCIES**

## D. Hydraulic distributors

If the top (bucket) and bottom (pedestal and remote control). If both of the control panels are out of order, the lift can be operated using the hydraulic distributors on the turret if the hydraulic power system is enabled. Remove the protective housing for access to the hydraulic distributors.

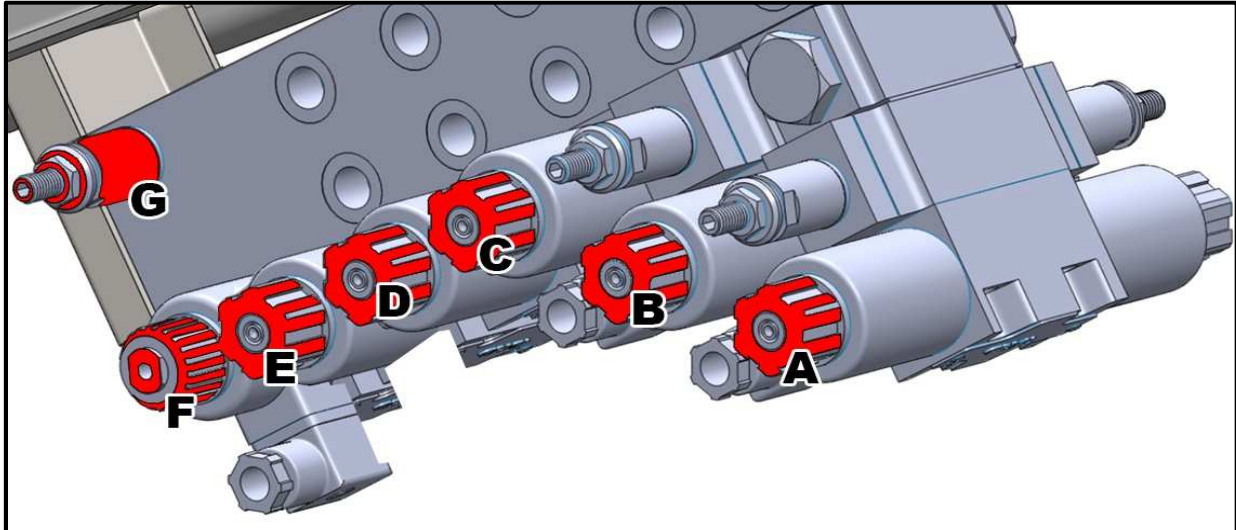

Index	Function	Passenger side	Driver's side
A	Horizontality management (Bucket levelling)	Forward tilting	Rearward tilting
B	Turret rotation	Clockwise rotation	Counterclockwise rotation
C	Extension/retraction of the telescopic boom	Retraction	Extension
D	Pendular boom lifting/lowering	Lowering	Lifting
E	Main boom lifting/lowering	Lowering	Lifting
F	Flow regulator	-	-
G	Main pressure relief valve	-	-



Unscrew the locking cap of the distributor to be actuated.

Screw the pushing clamp (provided with the elevator) on the distributor instead of the cap and turn the head to push or release the distributor (otherwise, without removing the locking cap, use a screwdriver to push the central piston and trigger the movement). Increase or decrease the speed of movement using the flow regulating wheel (See "E" in the above diagram).

## E. Actuator control

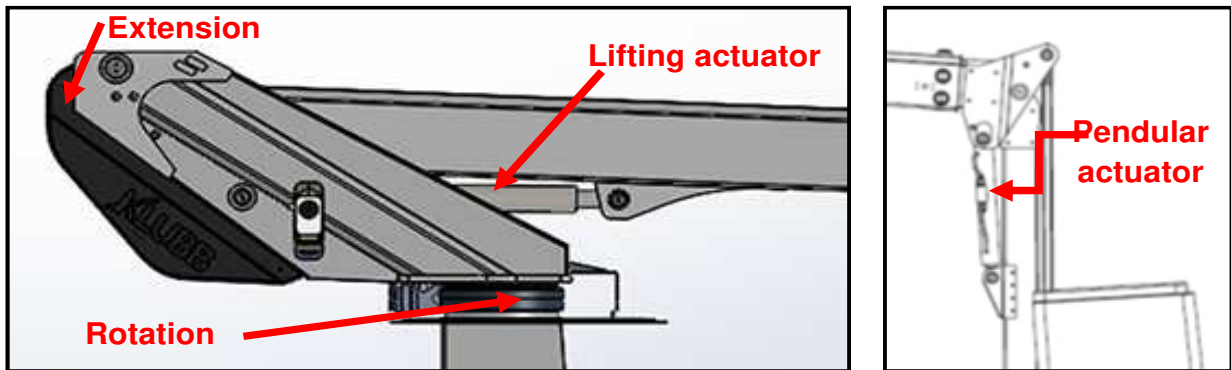

### ➤ Extension actuator:

**WARNING; DO NOT USE THIS METHOD WITHOUT MANUFACTURER'S AUTHORIZATION.**

If all of the hydraulic power sources are out of order, the telescope can be retracted using the actuator control screws.

The telescope will retract as soon as the hydraulic oil has passed through the control system. The more vertical the telescope, the more effective this maneuver will be, because of the effect of gravity.

The rate of descent increases according to the releasing of the screw.

To retract the telescopic boom, detach the locknut with a 17mm open-end wrench, turning the screw by 1/4 turns (counterclockwise) using a 5mm Allen wrench. Then push on the "RETRACTION" distributor (See Chapter VI D).

Release the distributor to stop the movement.

**AFTER USING THIS PROCEDURE, IT IS ESSENTIAL TO HAVE THE ACTUATOR CONTROLS ADJUSTED BY A QUALIFIED OPERATOR BEFORE USING THE ELEVATOR AGAIN.**

**Make sure that there are no obstacles in the way when the lift is returning.**

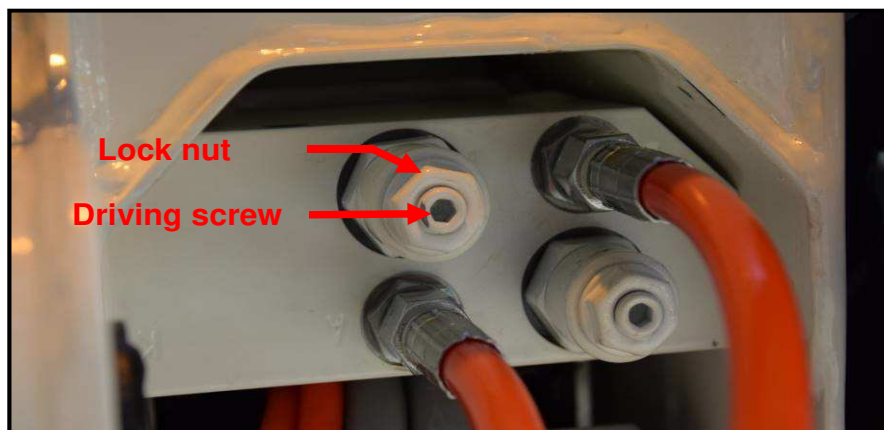



➤ **Lifting actuator:**

**WARNING: NOT TO BE CARRIED OUT WITHOUT MANUFACTURER'S AGREEMENT**

If all of the hydraulic power sources are out of order, the elevator mast can be lowered using the actuator control screws.

The mast will descend as soon as hydraulic oil has passed through the control system.

**CAUTION: THE GREATER THE UNSCREWING ACTION, THE GREATER THE RATE OF DESCENT. UNCONTROLLED UNSCREWING OF THE SCREW CAN LEAD TO THE ABRUPT LOWERING OF THE BOOM, CAUSING SERIOUS INJURIES OR EVEN DEATH.**

**THIS CAN BE A DANGEROUS OPERATION AND THE OPERATOR PERFORMING THE MANEUVER MUST MAKE SURE THERE IS NO OBSTACLE IN THE DESCENT CURVE OF THE BOOM, AND UNSCREW THE CONTROL SCREW SLOWLY.**

To lower the main mast onto the lifting actuator, unlock the lock nut using a 17 mm open end wrench, turning the screw by 1/4 turn (counterclockwise) using a 5 mm hexagon head wrench and actuating the "DOWN" distributor.

Release the distributor to stop the movement.

**AFTER USING THIS PROCEDURE, BE SURE TO HAVE QUALIFIED PERSONNEL ADJUST THE ACTUATOR CONTROLS BEFORE THE LIFT IS USED AGAIN.**

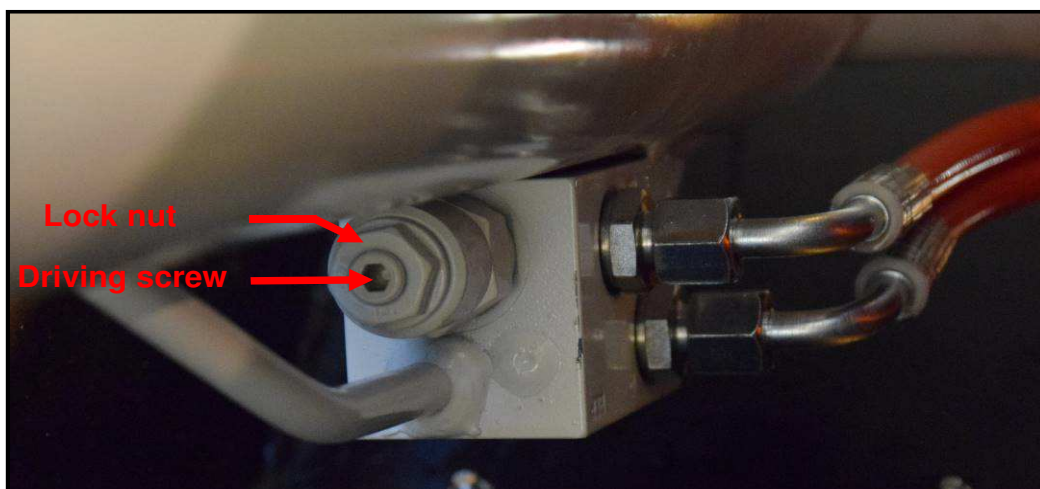

➤ **Pendular actuator :**

**WARNING: NOT TO BE CARRIED OUT WITHOUT MANUFACTURER'S AGREEMENT**

If all of the hydraulic power sources are out of order, the elevator mast can be lowered using the actuator control screws.

The mast will descend as soon as hydraulic oil has passed through the control system.

**CAUTION: THE GREATER THE UNSCREWING ACTION, THE GREATER THE RATE OF DESCENT. UNCONTROLLED UNSCREWING OF THE SCREW CAN LEAD TO THE ABRUPT LOWERING OF THE BOOM, CAUSING SERIOUS INJURIES OR EVEN DEATH.**

**THIS CAN BE A DANGEROUS OPERATION AND THE OPERATOR PERFORMING THE MANEUVER MUST MAKE SURE THERE IS NO OBSTACLE IN THE DESCENT CURVE OF THE BOOM, AND UNSCREW THE CONTROL SCREW SLOWLY.**

To lower the pendular boom onto the pendular actuator, unlock the lock nut using a 17 mm open end wrench, turning the screw by 1/4 turn (counterclockwise) using a 5 mm hexagon head wrench and actuating the "DOWN" distributor.

Release the distributor to stop the movement.

**AFTER USING THIS PROCEDURE, BE SURE TO HAVE QUALIFIED PERSONNEL ADJUST THE ACTUATOR CONTROLS BEFORE THE ELEVATOR IS USED AGAIN.**



➤ **Driving screw**

If all the hydraulic sources become inoperative, the mast will have to be turned by hand.

To avoid damage to the rotation slew gear, it is essential to release the pressure by unscrewing slightly the 2 flexible hoses connected to the slew gear with a 17 mm wrench. Place a recovery pan under the flexible hoses and let the oil flow out.

Use a 5 mm Allen key to remove the protective cover, then a ratchet wrench with a 19 mm socket to operate the hexagon. Turning clockwise will cause counterclockwise rotation of the turret and vice versa.

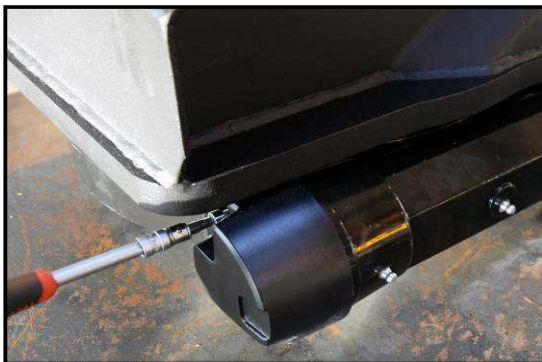

**Circuit breaker (available with optional GreenPack);**

Our boosting batteries comes with a circuit breaker allowing isolation if needed (battery failure, overheating, breakout of fire...).

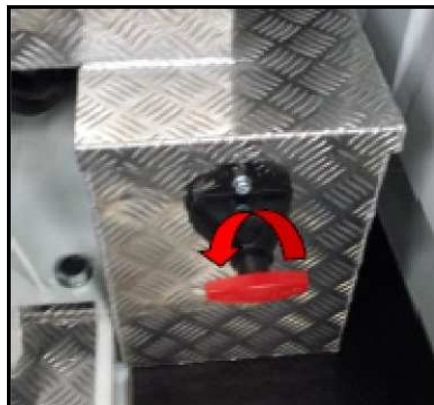

To activate the circuit breaker, turn the red lever counterclockwise.





## VII. MAINTENANCE

**Caution:** Any maintenance operation non covered in this manual must be authorized by KLUBB and made by its authorized operators.

**Caution:** Using spare parts that are not original or authorized by the manufacturer voids the warranty and relieves the company of all responsibility.

**Caution:** As far as components having a bearing on operator safety and health are concerned, it is essential to use only spare parts supplied by KLUBB.

**Caution:** It is prohibited to modify the MEPP except if prior authorization of the manufacturer is obtained.

All maintenance operations must be carried out in accordance with the specifications of Chapter III especially before performing servicing operations:

- Push the emergency shutdown button.
- Turn off the engine.
- Put on personal protective equipment.
- Isolate the machine from any energy supply sources.

**For maintenance, all MEPP movements must be controlled from the bottom remote control and without any person in the bucket.**

Concerning operation control from the elevated top control panel, perform the required movements while holding the bucket as close to the ground as possible.

When using the emergency ground station to control the MEPP, the operator is inside the MEPP working zone meaning that there is a constant risk of crushing in the event of a wrong maneuver. Carry out all movements as slowly and carefully as possible.

## A. Daily inspection

Every day, visual inspection of the elevator is necessary to detect any problems before they become serious. Special attention must be given to the following details:

- Hydraulic leaks: revealed by hydraulic oil spillage under the vehicle, on the floor and on the mast.
- Tires: check for appropriate inflation and any signs of damage
- Hydraulic oil level
- In winter, pay attention to protection from freezing by drainage or adding anti-freeze products.
- Bucket: check that the bucket is free of damage or cracking on the sides or in the bottom. If there is a problem, have the bucket repaired by a qualified repairer before use.
- Hydraulic pipes: check for for cracks and other damage.
- Electric cables (check that the protection sheathing is undamaged).
- Cradle boom (damage to paint, dented bodywork).
- Outrigger plates (check they are free of damage).
- Bolts: Examine all the bolts for any signs of loosening. Pay special attention to bolts holding the ratchet locking tabs or the ratchet lock washers, bearing assembly bolts and rotation supports.

Examine the retaining rings, the bolts of the barrels and the torsion bar.

Some critical bolts are marked with torque safety lead seals in order to provide a fast way of detecting any loosening. Do not use the elevator if a torque safety seal has been broken. Replace the bolts by a new bolt of the same grade, installed in the specified position by qualified personnel.



The photo opposite shows a torque safety lead seal in the unbroken condition.

- Welds: All the welds must be examined for signs of fatigue. Incipient cracks in a weld are serious signs of weld fatigue. A few critical welds, calling for special attention, are situated at the points where the flanges of the turrets are welded to the base, where the cylinder armatures are welded to the boom and the cylinder armatures are welded to the turret, and the platform support welds.



## **B. Weekly inspection**

In addition to daily inspection, check the following every week:

- Check the operation of the bottom remote control by using all of its functions. In particular, check the operation of the emergency pump.
- Emergency shutdown: test the operation of the 2 emergency shutdowns (PT and column)

## **C. Bimonthly inspection**

In addition to daily and weekly inspection, every 2 months, check:

- Emergency power system: check that the switch operates.
- Lubrication of rotation system.

## **D. Six monthly inspection**

In addition to the checks listed above:

- Replace the hydraulic filter element.
- Check the cleanliness and quality of the hydraulic oil: if it has emulsified or if it is dirty, drain and replace it.
- Check the pressure calibration (150 bars)



**E. Compulsory servicing after one year or 500 hours of use (whichever comes first)**



Fill in the following checklist during the inspection. Other copies of this checklist can be obtained on simple request to **KLUBB**.

Servicing every year or 500 hours (whichever comes first)								
Points to be checked	1 year or 500h		2 years or 1000h		3 years or 1500h		4 years or 2000h	
	Date	Hours	Date	Hours	Date	Hours	Date	Hours
Hydraulic leakage								
Oil filter change								
Oil change								
Operating pressure								
Condition of hydraulic unions								
Slew ring condition and greasing								
Rotation motor condition and greasing								
Greasing								
Actuator condition								
Bucket condition								
Fastening torque loads								
Electrical wiring condition								
Corrosion and distortion								
Emergency power system performance								
Power take off performance								
Elevator performance								
<b>Signature:</b>								

**Observations:**



## F. Hydraulic oils / filters

The elevator is supplied with hydraulic oil (TITAN FUCH H32 oil). This oil is made for use in "temperate climates" and provides good service at regular temperatures. H46 oil is also suitable but its compulsory to use an HV type oil

The oil filter must be changed after the first 30 days of use and then after 1 year or 500h of use (whichever comes first) depending on how often the elevators is used.

Pump cavitation denoted by noisy operation is due to a clogged filter, a low oil level or weather conditions there are too cold for the type of oil being used.

To change the oil filter, unscrew the filter block and replace it with a new one, carefully and slightly oiling the gasket.

## G. Greasing

### ➤ Slew ring

The slew ring is supplied correctly lubricated.

- Greece to be used: VANGUARD SILEX PLS/3
- Operating temperature: -35/+130°C

Compliant greases:

- |                             |                         |
|-----------------------------|-------------------------|
| - TOTAL CALORIS M/3         | - FUCHS RENOLIT FLM/2   |
| - FINA BENTEX 5M            | - BP GREASE LTX/2M      |
| - SHELL RETINAX HDX         | - AGIP GREASE SM/2      |
| - MOBIL MOBILGREASE SPECIAL | - CASTROL MOLY GREASE/2 |

Lubricating frequency:

Machine conditions of use	Greasing intervals (1 <sup>st</sup> completed term)
Clean and dry environment, mild climate.	Every 300h of use Or every 6 months
Dirty, dusty or sandy environment, coastal locations.	Every 200h of use Or every 4 months
Extreme conditions	Every 70h of use Or every 2 months

**Note:** The slew gear consists of 4 greasers: 3 along the hydraulic motor/worm screw assembly and one 45° angle greaser inside the fixed ring near the turret tube in the column. The latter is more critical and increasing recommendations must be complied with to the letter.

### ➤ Shafts

All the shafts of the machine are mounted on self-lubricating bearings and therefore do not require lubrication.



## H. Warranty cover

Warranty cover depends on compliance with these maintenance procedures.

At the end of this document, space is left for traceability to cover these maintenance operations.

## I. Diagnostic

This chapter contains a description of simple problems that can occur during the operation of the system.

For any issue not appearing in the following, or if the trouble continues after the action of the operator, get in touch with the after sales service.

### **User**

Operations that can be carried out by the user can only be done safely after carefully reading and understanding all the instructions given in this document.

### **Technician in charge of servicing**

The operations that can be performed by the technician assigned to maintenance can only be carried out safely by trained, qualified and authorized personnel who must have read all the instructions in this manual.



Problem	Cause	Solution	Operator
<b>General</b>			
No movement	No electrical power	Activate	User
	Vehicle door open	Close the door	User
<b>Power take off/pump</b>			
No movement of P.T.E.	Power Take Off does not operate	Activate	User
		Check the mechanical activation installation of the power take off	Maintenance operator
	Hydraulic pump discrepancy	Check the pressure	Maintenance operator
	Oil-hydraulic installation rubber pipes broken	After-sales service	Maintenance operator
	Pressure relief valve badly wrongly calibrated	Calibration	Maintenance operator
	No hydraulic oil	Find the causes and fill the tank	Maintenance operator
	No electric energy to solenoid valves	Check the electric installation and fuses	Maintenance operator
<b>Stabilizers</b>			
Stabilizers fail to retract	The PTE is not in the rest position (the boom is not at rest on the strut and/or ladder is extended for versions with an extending ladder)	Position it correctly	User
No movement	No electrical power	Inspect	Maintenance operator
No movement	Mini contact breaker on boom/outrigger locking system defective	Inspect	Maintenance operator
Intermittent operation of the outriggers	Irregular operation of hydraulic pump	Check the pressure and replace if necessary	User for inspection Maintenance technician in charge of replacement
	Excessive actuator seal where	Replace part	Maintenance operator
	Blocked valves		



<b>No movement of elevator bucket</b>			
No movement	Incorrect leveling of elevator bucket	Position it correctly	User
	Emergency shutdown not released	Disengage	
	Movement limiter out of order	After-sales service	After-sales service
	Travel end devices defective		
	Incorrect calibration of pressure relief valve	Calibration	Maintenance operator
No movement	Mini contact breaker on boom/outriggers locking system defective	Reactivate	Maintenance operator
	Limiter deactivated	Re-activated by pressing appropriate button and checking mini circuit breakers (see "emergency procedures" chapter).	Users
	Bucket gate opened (lifted)	Close the gate correctly	Users
	Bucket gate mobile access protection micro-switch defective (small gate)	Reactivate	Maintenance operator
	<b>Elevator moving irregularly</b>		
Irregular movements	Air in hydraulic power system	After-sales service	After-sales service
	Incorrect setting of the electronic card		
	Cylinder rod seized		
	Internal oil leaks		
	Faulty valves		
	Defective installation electric contacts		





## VIII. ELIMINATION AND DEMOLITION

### A. Operator qualification

Qualified mechanics who have read and understood chapter III *Safety information* and the chapter IX *Elimination and demolition*.

### B. Equipment deactivation

As soon as the lifetime has been reached, it must be dismantled. Decommissioning must guarantee that the equipment cannot be used for the purpose for which it was designed and built; it must also allow the recovery of the raw materials.

The company cannot be held liable for any injuries to people or animals or any damage to property caused by the reuse of equipment parts for purposes or assembly situations differing from the original conditions.

### C. Deactivation procedure

**DEACTIVATION AND REMOVAL PROCEDURES MUST BE CARRIED OUT BY SUITABLY TRAINED AND EQUIPPED PERSONNEL.**

Deactivation procedure:

- Set up the machine in the rest position
- Turn off the engine.
- Collect oil from the tank, pipes and cylinders
- Remove all the flexible rubber pipes
- Remove the electric cables

**Caution:** Hand the oils over to the appointed organizations for the elimination of spent oil.

**Caution:** Flexible rubber pipes must be handed over to authorized collection and recycling centers

**Caution:** Electric cables must be handed over to specific recycling centers

**Caution:** Parts of steel, light alloy etc. must be handed over to the specific centers for recovering these materials, as specified by the applicable standards.

### D. Remaining risks after deactivation

By correctly accomplishing the instructions of paragraph IX.C: *Deactivation procedure*, there is no use residual risk after deactivation



## IX. HYDRAULIC AND ELECTRIC DIAGRAMS

### A. Hydraulic drawings

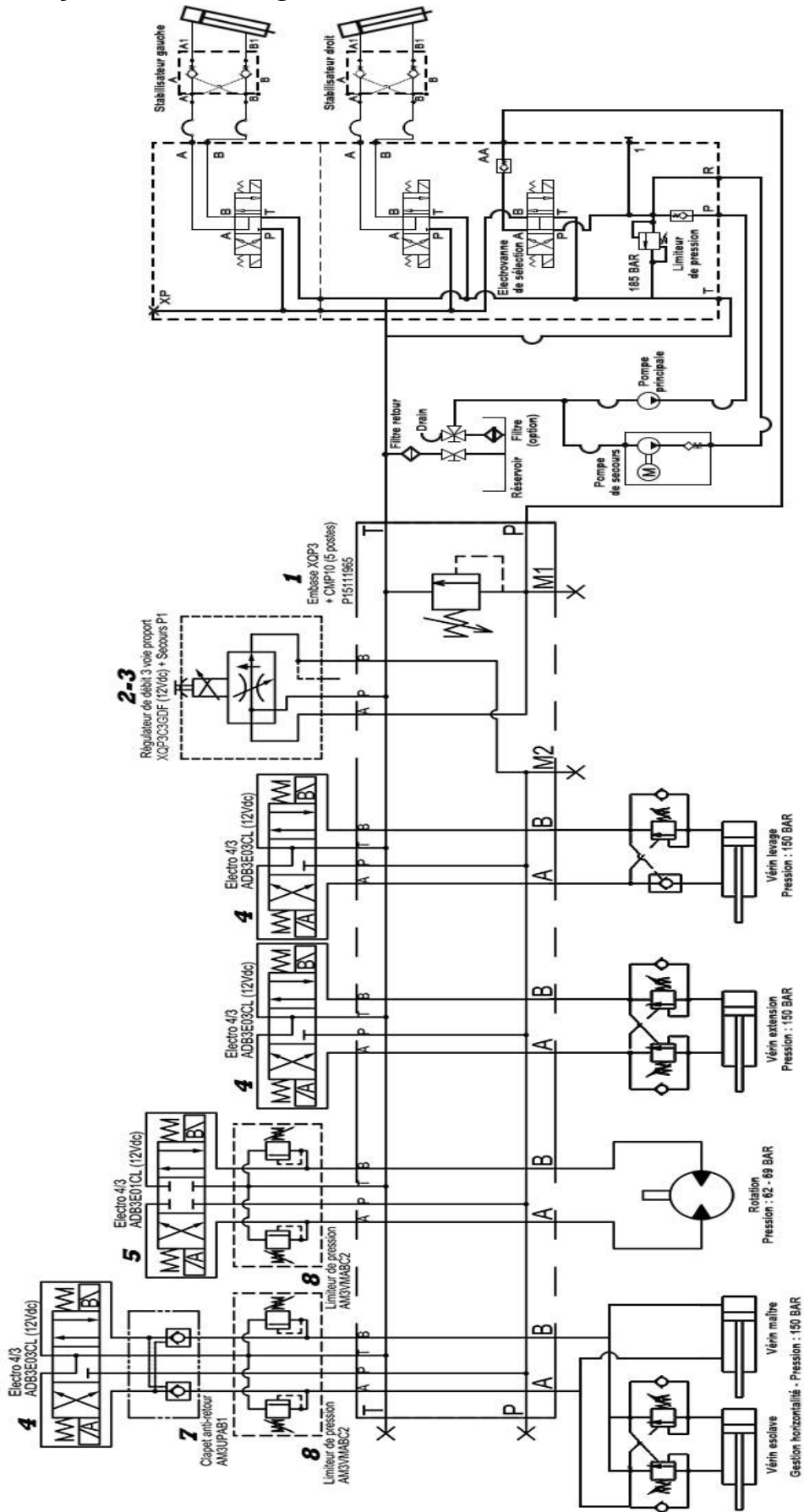



## B. Circuit drawings



## CONTROL REGISTER

This control register is distributed by **KLUBB** to the user of the elevator.

### A. Writing instructions

This record is part of the MEPP and must be kept with the machine until the end of its lifetime. The instructions in this manual are given according to known elements on the date of the first marketing of the elevator. Other arrangements may mean a change to the obligations of the user.

This record is designed for keeping track, according to the proposed diagrams, of the following events concerning the life of the elevator:

- Transfers of ownership
- Change and renewal of parts and safety devices
- Servicing checks

### B. Delivery of platforms owner

Elevator platform:

Serial ..... number:

Year of manufacture: .....

Was delivered with this control record by KLUBB

On (date) .....

At: .....

In accordance with the conditions of the contract, with the technical properties, sizes and specific functions described in the manual and the summary of this record.

KLUBB official

Owner

.....

.....



### C. Successive ownership transfers

**Copy to be preserved:**

Date: ..... ownership of the MEPP:

Serial ..... number:

Year of manufacture: .....

Was transferred to: .....

It is confirmed that on the aforementioned date, the technical, dimensional and functional properties of the platform in question conform to those originally provided for and that any changes have been specified in this record.

Company name of seller: .....

Seller

Buyer

---

**Copy to be sent to KLUBB**

Date: ..... ownership of the MEPP:

Serial ..... number:

Year of manufacture: .....

Was transferred to: .....

It is confirmed that on the aforementioned date, the technical, dimensional and functional properties of the platform in question conform to those originally provided for and that any changes have been specified in this record.

Company name of seller: .....

Seller

Buyer



### D. Replacement of parts

Serial number: .....

Description of the parts: .....

.....

Description of manufacturer: .....

.....

Supplier: .....

Reason for replacement: .....

.....

Responsible for replacement

User

.....

---

Date: .....Replacement of: .....

Serial number: .....

Description of part: .....

.....

Description of manufacturer: .....

.....

Supplier: .....

Reason for replacement: .....

.....

Responsible for replacement

User

.....

---

Date: .....Replacement of: .....

Serial number: .....

Description of part: .....

.....

Description of manufacturer: .....

.....

Supplier: .....

Reason for replacement: .....

.....

Responsible for replacement

User

.....



Date: .....Replacement of: .....  
Serial number: .....  
Description of part: .....  
.....  
Description of manufacturer: .....  
.....  
Supplier: .....  
Reason for replacement: .....  
.....

Responsible for replacement

User

.....

.....

---

Date: .....Replacement of: .....  
Serial number: .....  
Description of part: .....  
.....  
Description of manufacturer: .....  
.....  
Supplier: .....  
Reason for replacement: .....  
.....

Responsible for replacement

User

.....

.....

---

Date: .....Replacement of: .....  
Serial number: .....  
Description of part: .....  
.....  
Description of manufacturer: .....  
.....  
Supplier: .....  
Reason for replacement: .....  
.....

Responsible for replacement

User

.....

.....





Serial number: .....

Description of the parts: .....

Description of manufacturer: .....

Supplier: .....

Reason for replacement: .....

Responsible for replacement

User

---

Date: ..... Replacement of: .....

Serial number: .....

Description of part: .....

Description of manufacturer: .....

Supplier: .....

Reason for replacement: .....

Responsible for replacement

User

---

Date: ..... Replacement of: .....

Serial number: .....

Description of part: .....

Description of manufacturer: .....

Supplier: .....

Reason for replacement: .....

Responsible for replacement

User



### E. Safety replacement

Date: .....

Checked elements; .....

.....

.....

.....

Person in charge of maintenance; .....

---

Date: .....

Checked elements; .....

.....

.....

.....

Person in charge of maintenance; .....

---

Date: .....

Checked elements; .....

.....

.....

.....

Person in charge of maintenance; .....



Date: .....

Checked elements; .....

.....

.....

.....

Person in charge of maintenance; .....

---

Date: .....

Checked elements; .....

.....

.....

.....

Person in charge of maintenance; .....

---

Date: .....

Checked elements; .....

.....

.....

.....

Person in charge of maintenance; .....



## F. Checking / repairs / maintenance

Date: .....

Checked elements; .....

.....

.....

.....

Person in charge of maintenance; .....

---

Date: .....

Checked elements; .....

.....

.....

.....

Person in charge of maintenance; .....

---

Date: .....

Checked elements; .....

.....

.....

.....

Person in charge of maintenance; .....



Date: .....

Checked elements; .....

.....

.....

.....

Person in charge of maintenance; .....

---

Date: .....

Checked elements; .....

.....

.....

.....

Person in charge of maintenance; .....

---

Date: .....

Checked elements; .....

.....

.....

.....

Person in charge of maintenance; .....



Date: .....

Checked elements; .....

.....

.....

.....

Person in charge of maintenance; .....

---

Date: .....

Checked elements; .....

.....

.....

.....

Person in charge of maintenance; .....

---

Date: .....

Checked elements; .....

.....

.....

.....

Person in charge of maintenance; .....



## G. Notes

A series of 25 horizontal dotted lines for taking notes.





A large area of the page consisting of numerous horizontal dotted lines, intended for handwritten notes or a checklist.



A large area of the page consisting of 25 horizontal dotted lines, intended for handwritten notes or a checklist.