



647884 EN-USM1 (C-02/2024)

M70-2 H D ST5 S1 EU

OPERATOR'S MANUAL
(ORIGINAL INSTRUCTIONS)

**IMPORTANT**

Carefully read and understand this instruction manual before using this machine.

It contains all information relating to operation, handling and equipment, as well as important recommendations to be followed.

This document also contains precautions for use, as well as information on the service and routine maintenance required to ensure the machine's continued reliability and safety of use.

WHENEVER YOU SEE THIS SYMBOL, IT MEANS:



NOTE! BE CAREFUL! YOUR SAFETY, THAT OF OTHERS, OR THE SAFETY OF THE MACHINE IS AT RISK.

- This manual has been produced based on the equipment list and technical characteristics given at the time of its design.
- The machine's equipment level depends on the options chosen and the country of sale.
- Depending on the machine's options and the date of sale, certain equipment or functions described in this manual may not be present on this machine.
- Descriptions and figures are nonbinding.
- MANITOU reserves the right to change its models and their equipment without being required to update this manual.
- The MANITOU network, consisting exclusively of qualified professionals, is available to answer all your questions.
- This manual is an integral part of the machine.
- It is to be kept in its storage location at all times for ease of reference.
- Give this manual to the new owner if the machine is resold.



1 st EDITION	A-11/2020	
UPDATE	B-00/2023	1-1 – 1-20 2-6 – 2-46 3-4 ; 3-5 ; 3-9 ; 3-11 ; 3-14
	C-02/2024	1-1 – 1-18 2-1 – 2-40 3-1 – 3-42



The brochure and all its contents, including diagrams, are the proprietary and confidential intellectual property of Manitou BF and / or its subsidiaries ("Manitou Group"). Any reproduction, publication or dissemination of any part of the brochure without the express written authorization of Manitou Group is strictly prohibited. Any violation of this provision will subject the offending party to prosecution by Manitou Group to the fullest extent of the law. The logos and the company's visual identity are the property of Manitou Group and may not be used without the express written authorization of Manitou Group.

All trademarks, registered and unregistered, is and shall remain the property of Manitou BF or its respective owner.

Any reproduction, source code access, decompilation, modification, copy (other than backup copies), correction of errors, transmission or distribution of any software built into Manitou Group machines is strictly prohibited.

In the event that the measures above nevertheless prove essential to enable use of the software, in accordance with its destination, or to obtain the information required for interoperability with other software created independently, the user should contact Manitou Group in advance and Manitou may, at its sole discretion, take the necessary measures or give access to only the information strictly necessary for interoperability.

Any breach of these requirements is likely to constitute a counterfeiting offense subject to legal action by Manitou Group.

Connected Manitou Group machines are equipped with boxes that collect technical data on the machines (such as geo-tracking data or data on component operation). This data, which is organized, processed and enhanced by algorithms and expertise proprietary to Manitou Group, constitutes, in combination with other elements, independent or not, a protected database according to laws & regulations on IP purposes.

It is strictly forbidden to have access to all or part of this database and to use the data (including in the event of accidental access) without explicit prior authorization from Manitou Group. In the event that Manitou Group authorizes a Manitou Group machine user to access all or part of this database, Manitou Group, as producer of this database, cedes to the user only a right to personal, non-exclusive, non transferable use of the database, and only by access to an information technology platform hosted by a server owned or controlled by Manitou Group.

In any case, the following are strictly prohibited:

- any extraction, reproduction, representation, reuse through provision to the public, distribution, transfer, permanent or temporary, on any medium, by any means, and in any form whatsoever, of all or of a qualitatively or quantitatively substantial part of the contents of this database,*
- any extraction, reproduction, representation, reuse through provision to the public, distribution, transfer, repeated or systematic of qualitatively or quantitatively insubstantial parts of the content of the database during operations manifestly exceeding normal use of the database by the user of the machine for his own needs,*
- any use of means to bypass technical protection measures for databases or software source code embedded in the boxes, in keeping according to laws & regulations on IP purposes.*

*The latest updated version in force and binding of this document is the version available on demand.
Only the electronic version is maintained.*

MANITOU BF S.A. Public limited company with a board of directors.

Head office: 430 rue de l'Aubinière - 44150 Ancenis - France

Share capital: €39,548,949

Entered in the Nantes Trade and Companies Register under number 857 802 508.

Tel.: +33 (0) 2 40 09 10 11

1 - OPERATING AND SAFETY INSTRUCTIONS

2 - DESCRIPTION

3 - MAINTENANCE

4 - ATTACHMENTS







1 - OPERATING AND SAFETY INSTRUCTIONS



1 - OPERATING AND SAFETY INSTRUCTIONS

INSTRUCTIONS TO THE COMPANY MANAGER

1-4

THE SITE	1-4
THE OPERATOR	1-4
THE MACHINE	1-4
A - SUITABILITY OF THE MACHINE FOR THE TASK	1-4
B - ADAPTING THE MACHINE TO USUAL ENVIRONMENTAL CONDITIONS	1-4
C - MODIFYING THE MACHINE	1-5
D - FRENCH ROAD TRAFFIC RULES	1-5
INSTRUCTIONS	1-5
MAINTENANCE	1-5

INSTRUCTIONS TO THE OPERATOR

1-6

FOREWORD	1-6
GENERAL INSTRUCTIONS	1-6
A - OPERATOR'S MANUAL	1-6
B - AUTHORIZATION FOR USE IN FRANCE	1-6
C - MAINTENANCE	1-6
D - MODIFYING THE MACHINE	1-6
E - LIFTING PEOPLE	1-6
OPERATING INSTRUCTIONS UNLADEN AND LADEN	1-7
A - BEFORE STARTING UP THE MACHINE	1-7
B - DRIVER'S OPERATING INSTRUCTIONS	1-7
C - ENVIRONMENT	1-7
D - VISIBILITY	1-8
E - STARTING THE MACHINE	1-8
F - OPERATING THE MACHINE	1-9
G - STOPPING THE MACHINE	1-10
H - DRIVING THE MACHINE ON THE PUBLIC HIGHWAY	1-10
INSTRUCTIONS FOR HANDLING A LOAD	1-11
A - CHOICE OF ATTACHMENTS	1-11
B - WEIGHT OF LOAD AND CENTRE OF GRAVITY	1-11
C - TRANSVERSE ATTITUDE OF THE MACHINE	1-11
D - PICKING UP A LOAD ON THE GROUND	1-12
PICKING UP AND LAYING DOWN A HIGH LOAD ON TIRES	1-12

MACHINE MAINTENANCE INSTRUCTIONS

1-14

GENERAL INSTRUCTIONS	1-14
MAINTENANCE	1-14
LUBRICANT AND FUEL LEVELS	1-14
HYDRAULICS	1-14
ELECTRICITY	1-14
WELDING	1-15
WASHING THE MACHINE	1-15
TRANSPORTING THE MACHINE	1-15



PROLONGED MACHINE SHUTDOWN

1-16

INTRODUCTION	1-16
PREPARATION OF THE MACHINE	1-16
DEF (Diesel Exhaust Fluid) TANK	1-16
PROTECTING THE ENGINE	1-16
MACHINE PROTECTION	1-16
RETURNING THE MACHINE TO SERVICE	1-17

DISPOSING OF THE MACHINE

1-18

RECYCLING OF MATERIALS	1-18
METALS	1-18
PLASTICS	1-18
RUBBER	1-18
GLASS	1-18
ENVIRONMENTAL PROTECTION	1-18
WORN OR DAMAGED PARTS	1-18
USED OIL	1-18
USED BATTERIES.	1-18



INSTRUCTIONS TO THE COMPANY MANAGER

THE SITE

- Proper management of the machine's area of travel will reduce the risk of accidents:
 - Ground not unnecessarily uneven or obstructed,
 - No excessive slopes,
 - Pedestrian traffic controlled, etc.

THE OPERATOR

- Only qualified, authorized personnel can use the machine. This authorization is given in writing by the appropriate person in the establishment where the machine is to be used and must be carried permanently by the operator.

⚠ IMPORTANT ⚠

Experience has shown that there are a number of inappropriate ways in which the machine might be used. Such foreseeable misuse, of which the main examples are listed below, are strictly forbidden.

- *The foreseeable abnormal behavior resulting from ordinary negligence, but not from any intentional misuse of the equipment.*
- *The reflex reactions of a person in the event of a malfunction, incident, fault, etc. during operation of the machine.*
- *Behavior resulting from application of the "principle of least effort" when performing a task.*

- *For certain machines, the foreseeable behavior of such persons as: apprentices, teenagers, handicapped persons, trainees tempted to drive a machine, operators tempted to operate a machine to win a bet, in competition or for their own personal experience.*

The person in charge of the equipment must take these criteria into account when assessing whether or not a person will make a suitable driver.

THE MACHINE

A - SUITABILITY OF THE MACHINE FOR THE TASK

- This machine is a lift truck designed for handling (moving, storing or transporting) a load.
- MANITOU has ensured that this machine is suitable for use under the standard operating conditions defined in this operator's manual, with a **STATIC TEST COEFFICIENT OF 1.33** and a **DYNAMIC TEST COEFFICIENT OF 1**, as specified in harmonized standard **ISO 3691-1** for masted forklift trucks.
- Before commissioning, the company manager must make sure that the machine is appropriate for the work to be done, and perform certain tests (in accordance with current legislation).

B - ADAPTING THE MACHINE TO USUAL ENVIRONMENTAL CONDITIONS

- In addition to the standard equipment mounted on your machine, many options are available, such as: road lighting, stop lights, revolving light, reverse lights, reverse buzzer alarm, front light, rear light, etc.
- The operator must take into account the operating conditions to specify the machine's signaling and lighting equipment. Consult your dealer.
- Take into account the climatic and atmospheric conditions of the site of utilization.
 - Protection against frost (≤ 3 - MAINTENANCE).
 - Adaptation of lubricants (ask your dealer for information).
 - Engine filtration (≤ 3 - MAINTENANCE).

⚠ IMPORTANT ⚠

For operation under average climatic conditions, i.e. between -15 °C and +35 °C, correct levels of lubricants in all the circuits are checked in production. -15 °C to +35 °C.

For operation under more severe climatic conditions, before starting up, drain all circuits, then fill using lubricants suitable for the ambient temperatures.

The same applies to the coolant.

- Preventing fire risks associated with use in dusty and flammable conditions (e.g. straw, flour, sawdust, organic waste, etc.).
- A machine operating in an area without fire extinguishing equipment must be equipped with an individual extinguisher. Solutions exist, consult your dealer.

⚠ IMPORTANT ⚠

Your machine is designed for outdoor use under normal atmospheric conditions and indoor use in suitably aerated and ventilated premises.

It is prohibited to use the machine in areas where there is a risk of fire or which are potentially explosive (e.g. refineries, fuel or gas depots, stores of inflammable products, etc.).

Special equipment is available for use in such areas (ask your dealer for information).



- Our machines comply with Directive 2004/108/EC concerning electromagnetic compatibility (EMC) (UK: Electromagnetic Compatibility Regulations 2016), and with the corresponding harmonized standard EN 12895. Their correct operation is no longer guaranteed if they are used within areas in which the electromagnetic fields exceed the limit specified by this standard (10 V/m).

⚠ IMPORTANT ⚠

After commissioning, any machine equipped with devices that are likely to emit non-ionizing radiation (e.g. radio transmitter, radiofrequency ID reader, data collection system, etc.) can cause injury, especially to people with active or inactive medical devices or implants.

- Directive 2002/44/EC requires company managers to not expose their employees to excessive vibration doses. There is no recognized code of measurement for comparing the machines of different manufacturers. The actual doses received cannot therefore be measured under actual operating conditions at the user's premises.
- The following are some tips for minimising these vibration doses:
 - Select the most suitable machine and attachment for the intended use.
 - Adapt the seat adjustment to the operator's weight (depending on machine model) and maintain it in good condition, as well as the cab suspensions. Inflate the tires in accordance with recommendations.
 - Ensure that the operators adapt their operating speed to suit the conditions on site.
 - As far as possible, arrange the site in such a way as to provide a flat running surface and remove obstacles and harmful potholes.

C - MODIFYING THE MACHINE

- For your own safety and that of others, you must not change the structure and settings of the various components of your machine by yourself (hydraulic pressure, limiter calibration, engine speed, addition of extra equipment, addition of counterweights, unapproved attachments, alarm systems, etc.). In this case, the manufacturer cannot be held responsible.

D - FRENCH ROAD TRAFFIC RULES

- Only one certificate of conformity is issued. It must be kept in a safe place.
- The driving of non-approved machines on the public highway is subject to the provisions of the highway code relating to special machines, defined in Article R311-1 of the French Highway Code (*Code de la route*), in category B of the Equipment Order of 20 November 1969 that determines the procedures applicable to special machines. The machine must be fitted with an operating license plate.

INSTRUCTIONS

- The operator's manual must always be in good condition and kept in the place provided in the machine and in the language used by the operator.
- Operator's manuals and any plates or stickers which are no longer legible or are damaged, must be replaced.

MAINTENANCE

- Maintenance or repairs other than those detailed in Part: 3 - MAINTENANCE must be carried out by qualified personnel (consult your dealer) and under the necessary safety conditions to maintain the health of the operator and any third party.

⚠ IMPORTANT ⚠

Your machine must be periodically inspected to ensure its continued compliance.

The frequency of this inspection is defined by the legislation in force in the country in which the machine is used.

- Example for France "The manager in charge of the establishment using a machine must open and maintain a maintenance log for each machine (order of March 2, 2004) and undergo a general periodic inspection every 6 months (order of March 1, 2004)".



INSTRUCTIONS TO THE OPERATOR

FOREWORD

⚠ IMPORTANT ⚠

The risk of accident while using, servicing or repairing your machine can be reduced if you follow the safety instructions and preventive measures detailed in this manual. Failure to respect the safety and operating instructions, or the instructions for repairing or servicing your machine, may lead to serious, even fatal accidents. In order to reduce or prevent any danger with a MANITOU-approved attachment, follow the instructions in paragraph: 4 - ADAPTABLE ATTACHMENTS AVAILABLE ON THE RANGE: INTRODUCTION.

- Only the operations and manoeuvres described in this operator's manual must be performed. The manufacturer cannot predict all possible risky situations. Consequently, the safety instructions given in the operator's manual and on the machine itself are not exhaustive.
- As the operator, you must anticipate at all times the potential risks for yourself, for others and for the machine.

GENERAL INSTRUCTIONS

A - OPERATOR'S MANUAL

- Read the operator's manual carefully.
- The operator's manual must always be in good condition and in the place provided for it on the machine.
- You must report any plates and stickers which are no longer legible or which are damaged.

B - AUTHORIZATION FOR USE IN FRANCE

(or see current legislation in other countries)

- Only qualified, authorized personnel can use the machine. This authorization is given in writing by the appropriate person in the establishment where the machine is to be used and must be carried permanently by the operator.
- The operator is not cleared to authorize the driving of the machine by another person.

C - MAINTENANCE

- If the operator observes that his machine is not in good working order or does not comply with the safety instructions must inform his manager of this immediately.
- The operator is prohibited from carrying out any repairs or adjustments himself, unless he has been trained for this purpose. He must keep his machine perfectly clean if he is responsible for this task.
- The operator must carry out daily and weekly maintenance (↪ 3 - MAINTENANCE).
- For the safety of the operator, maintenance must be carried out with the engine off and the ignition key removed.
- The operator must ensure tyres are appropriate for the type of ground (↪ 2 - DESCRIPTION). Optional solutions are available, please consult your dealer.
 - SAND tires.
 - FARM tires.
 - Snow chains.

⚠ IMPORTANT ⚠

Do not use the machine if the tires are damaged or excessively worn, because this could put your own safety or that of others at risk, or cause damage to the machine itself. The fitting of foam inflated tires is prohibited and is not guaranteed by the manufacturer unless with prior authorization.

- The operator is responsible for adjusting the frequency of cleaning needed to prevent the risk of fire ensuing from the build-up of flammable material(s).
- The operator should pay special attention to all the areas of the machine where these high-risk materials are likely to accumulate.

D - MODIFYING THE MACHINE

- For your own safety and that of others, you must not change the structure and settings of the various components of your machine by yourself (hydraulic pressure, limiter calibration, engine speed, addition of extra equipment, addition of counterweights, unapproved attachments, alarm systems, etc.). In this case, the manufacturer cannot be held responsible.

E - LIFTING PEOPLE

- It is forbidden to lift or carry people.



OPERATING INSTRUCTIONS UNLADEN AND LADEN

A - BEFORE STARTING UP THE MACHINE

- Perform the daily maintenance operations (↩ 3 - MAINTENANCE).
- Make sure that the driver's cab is clean, particularly the floor and floor mat. Check that no movable objects may hinder operation of the machine.
- Make sure the lights, turn signals and windshield wipers are working properly.
- Make sure the rear-view mirrors are in good condition, clean and properly adjusted.
- Make sure the audible alarm works.

B - DRIVER'S OPERATING INSTRUCTIONS

⚠ IMPORTANT ⚠

Under no circumstances must the seat be adjusted while the machine is moving.

For cabs with a heating system, check the temperature setting to prevent any risk of burns from the heating vents.

- Whatever his experience, the operator is advised to familiarize himself with the position and operation of all the controls and instruments before operating the machine.
- Wear clothes suitable for driving the machine, avoid loose clothing.
- Make sure you have the appropriate protective equipment for the task to be performed.
- Prolonged exposure to high noise levels may cause hearing problems. It is recommended to wear ear muffs to protect against excessive noise.
- Always face the machine when getting into and out of the driver's cab:
 - Use the handle(s) provided for this purpose.
 - Use the step(s).
 - Do not jump out of the machine.
- Remain alert at all times when using the machine. Do not listen to the radio or music using headphones or earphones.
- Never operate the lift truck when hands or feet are wet or soiled with greasy substances.
- For increased comfort, adjust the seat to your requirements and adopt the correct position in the driver's cab.
- The operator must always be in the normal operator's position. Arms and legs, and generally any part of the body, should be kept inside the driver's cab of the machine.
- The safety belt must be worn and adjusted to the operator's size.
- The control units must never be used for any other than their intended purposes (e.g. Climbing onto or down from the machine, coat hanger, etc.).
- If the control components are fitted with a forced operation (lever lock) device, it is forbidden to leave the cab without first putting these controls in neutral.
- It is prohibited to carry passengers either on the machine or in the cab.

C - ENVIRONMENT

- Comply with site safety regulations.
- If you have to use the machine in a dark area or work at night, make sure it is equipped with work lights.
- During handling operations, make sure that no one is in the way of the machine and its load.
- Do not allow anybody to come near the working area of the machine or pass beneath an elevated load.
- The maximum slope on which the machine can be used in relation to the capacity of the service brake is 20%.
- When using the lift truck on a transverse slope, before lifting the mast, follow the instructions given in the paragraph: INSTRUCTIONS FOR HANDLING A LOAD.

- Traveling on a longitudinal slope:

- Drive and brake gently.

- Moving without load: Forks or attachment facing downhill.



- Moving with load: Forks or attachment facing uphill.



- Take into account the machine's dimensions and its load before trying to negotiate a narrow or low passageway.
- Never move onto a load bridge without having first checked:
 - That it is suitably positioned and made fast.
 - That the unit to which it is connected (wagon, truck, etc.) will not shift.
 - That this bridge is prescribed for the total weight of the machine, laden or unladen.
 - That this bridge is prescribed for the size of the machine.
- Never move onto a foot bridge, floor or freight lift, without being certain that they are suitable for the weight and size of the machine, laden or otherwise, and without having checked that they are in sound working order.
- Be careful in the area of loading bays, trenches, scaffolding, soft ground and manholes.
- Make sure the ground is stable and firm under the wheels before lifting the load.
- Make sure that the scaffolding, loading platform, pilings or ground is capable of bearing the load.



- Never stack loads on uneven ground, they may tip over.
- The load or the attachment must not be left just above a structure for long periods at a time because of the descending mast. In such a case, a constant watch must be kept and the height of the forks or the attachment readjusted if necessary.
- In the case of work near to overhead lines, ensure that the safety distance is sufficient between the machine's working area and the overhead line.

⚠ IMPORTANT ⚠

You must consult your local electrical agency.

You could be electrocuted or seriously injured if you operate or park the machine too close to power cables.

In the event of high winds, do not carry out handling work that jeopardizes the stability of the machine and its load, particularly if the load catches the wind badly.

- Prevent fire risks associated with use in dusty and flammable conditions (e.g. straw, flour, sawdust, organic waste, etc.).

D - VISIBILITY

- The safety of people within the machine's working area, as well as that of the machine itself and the operator, are dependent on good operator visibility of the machine's immediate surroundings in all situations and at all times.
- This machine has been designed to allow good operator visibility (direct or indirect by means of rear-view mirrors) of the immediate surroundings of the machine while driving with no load and with the mast in the transport position.
- Special precautions must be taken if the size of the load restricts visibility towards the front:
 - Moving in reverse,
 - Site layout,
 - Assisted by a person directing the operation (while standing outside the machine's area of travel), making sure to keep this person clearly in view at all times,
 - At all events, avoid reversing long distances.
- If visibility of your road is inadequate, ask someone to assist by directing the operation (while standing outside the machine's area of travel), making sure to keep this person clearly in view at all times.
- Keep all components affecting visibility in a clean, properly adjusted state and in good working order (e.g. windshields, windows, windshield wipers, windshield washers, driving lights and worklights, rear-view mirrors).

E - STARTING THE MACHINE

SAFETY INSTRUCTIONS

⚠ IMPORTANT ⚠

The machine must only be started up or maneuvered when the operator is sitting in the driver's cab with seat belt fastened and adjusted.

- Never try to start the machine by pushing or towing it. Such an operation may cause severe damage to the transmission. If necessary, towing requires the transmission to be put in neutral (< 3 - MAINTENANCE).
- If using an emergency battery for start-up, use a battery with the same characteristics and respect battery polarity when connecting it. Connect at first the positive terminals before the negative terminals.

⚠ IMPORTANT ⚠

Failure to respect polarity between batteries can cause serious damage to the electrical circuit.

The electrolyte in the battery may produce an explosive gas. Avoid flames and generation of sparks close to the batteries.

Never disconnect a battery while it is being charged.

INSTRUCTIONS

- Check the closing and locking of the hood(s).
- For machines operating on gas carburization, open the gas bottle.
- Ensure that the forward/reverse selector is set to neutral.
- Turn the ignition key to the position I to activate the electrical and preheat system.
- Check the fuel level on the indicator.
- Turn the ignition key fully, the engine should then start. Release the ignition key and let the engine run at idling speed.
- Do not engage the starter motor for more than 15 seconds and carry out the preheating between unsuccessful attempts.
- Make sure all the signal lights on the control instrument panel are off.
- Check all control instruments when the engine is warm and at regular intervals during use, so as to quickly detect any faults and to be able to correct them without any delay.
- If an instrument does not show the correct display, stop the engine and immediately carry out the necessary operations.



F - OPERATING THE MACHINE

SAFETY INSTRUCTIONS

⚠ IMPORTANT ⚠

We would like to draw the operators' attention to the risks involved in using the machine, in particular:

- Risk of losing control.

- Risk of loss of lateral and frontal stability of the machine.

The operator must remain in control of the machine.

In the event of the machine overturning, do not try to leave the cab during the incident.

YOUR BEST PROTECTION IS TO STAY FASTENED IN THE CAB.

- Observe the company's traffic regulations or, by default, the public highway code.
- Do not carry out operations which exceed the capacities of your machine or attachment.
- Always drive the machine with the forks or attachment in the transport position, i.e. 300 mm from the ground and with the carriage sloping backward.
- Only carry loads which are balanced and properly anchored to avoid any risk of a load falling off.
- Ensure that pallets, cases, etc. are in good order and suitable for the load to be lifted.
- Familiarize yourself with the machine on the terrain where it will be used.
- Ensure that the service brakes are working properly.
- The engine speed during movement of the machine when loaded must not exceed the maximum value indicated in the machine's technical data.
- Drive smoothly at an appropriate speed for the operating conditions (land configuration, load on the machine).
- Reduce the lift truck's moving speed when transporting loads.
- Do not use the hydraulic mast controls when the machine is moving.
- Do not maneuver the machine with the mast in the raised position unless under exceptional circumstances and then with extreme caution, at very low speed and using gentle braking. Ensure that there is sufficient visibility.
- Take bends slowly.
- In all circumstances make sure you are in control of your speed.
- On damp, slippery or uneven terrain, drive slowly.
- Brake gently, never abruptly.
- Only use the machine's forward/reverse selector from a stationary position and never do so abruptly.
- Do not drive with your foot on the brake pedal.
- Always remember that hydrostatic type steering is extremely sensitive to movement of the steering wheel, so turn it gently and not jerkily.
- Never leave the engine running when the lift truck is unattended.
- Do not leave the cab when the machine has a raised load.
- Look where you are going and always make sure you have good visibility along the route.
- Use the rear-view mirrors frequently.
- Drive round obstacles.
- Never drive on the edge of a ditch or steep slope.
- It is dangerous to use two machines simultaneously to handle heavy or bulky loads, since this operation requires particular precautions to be taken. It must only be used exceptionally and after risk analysis.
- The ignition switch has an emergency stop mechanism in case of an operating anomaly occurring in the case of machines not fitted with a punch-operated cut-out.

INSTRUCTIONS

- Always drive the machine with the forks or attachment in the transport position, i.e. 300 mm from the ground and with the carriage sloping backward.
- For machines with gearboxes, use the selected gear (⚙ 2 - DESCRIPTION).
- Release the hand brake.
- Shift the forward/reverse selector to the selected direction of travel and accelerate gradually until the machine moves off.



G - STOPPING THE MACHINE

SAFETY INSTRUCTIONS

- Never leave the ignition key in the machine during the operator's absence.
- When the machine is stationary, or if the operator has to leave his cab (even for a moment), place the forks or attachment on the ground, apply the parking brake and place the forward/reverse selector in neutral.
- Make sure that the machine is not stopped in any position that will interfere with the traffic flow and at less than one meter from the track of a railway.
- In the event of prolonged parking on a site, protect the machine from bad weather, particularly from frost (check the level of antifreeze), and close and lock all the machine accesses (doors, windows, cowls, etc.).

INSTRUCTIONS

- Park the machine on flat ground or on an incline lower than 15%.
- Set the forward/reverse selector to neutral.
- Apply the parking brake.
- For machines with gearboxes, place the gear lever in neutral.
- Lower the forks or attachment to rest on the ground.
- When using an attachment with a grab or jaws, or a bucket with hydraulic opening, close the attachment fully.
- Before stopping the machine after intensive work, leave the engine idling for a few moments to allow the coolant and oil to lower the temperature of the engine and transmission. Do not forget this precaution, in the event of frequent stops or warm stalling of the engine, or else the temperature of certain parts will rise significantly due to the stopping of the cooling system, with the risk of badly damaging such parts.
- Stop the engine with the ignition switch.
- Remove the ignition key.
- At the end of the day, activate the battery cut-off, and if the machine is being shut down from more than 20 days, disconnect the battery.
- Lock all the accesses to the machine (doors, windows, cowls, etc.).
- For machines operating on gas carburization, close the gas bottle. For a long lasting stop, let the engine stop naturally by shutting the LPG bottle before switching off the ignition, so as to eliminate all the fuel in the feed tube.

H - DRIVING THE MACHINE ON THE PUBLIC HIGHWAY

FRENCH ROAD TRAFFIC RULES

- The driving of non-approved machines on the public highway is subject to the provisions of the highway code relating to special machines, defined in Article R311-1 of the French Highway Code (*Code de la route*), in category B of the Equipment Order of 20 November 1969 that determines the procedures applicable to special machines. The machine must be fitted with an operating license plate.

SAFETY INSTRUCTIONS

- Operators driving on the public highway must comply with current highway code legislation.
- The machine must comply with current road legislation. If necessary, there are optional solutions. Contact your dealer.

INSTRUCTIONS

- Make sure the revolving light is in place, switch it on and verify its operation.
- Make sure the lights, turn signals and windshield wipers are working properly.
- Switch off the worklights if the machine is fitted with them.
- Place the attachment 300mm from the ground.

⚠ IMPORTANT ⚠

Never coast in neutral (forward/reverse selector or gear lever in neutral or transmission cut-off button pressed) to preserve the machine's engine brake. Failure to observe this instruction on a slope will lead to excessive speed, which may make the machine uncontrollable (steering, brakes) and cause serious mechanical damage.

DRIVING THE MACHINE WITH A FRONT-MOUNTED ATTACHMENT

- You must comply with current regulations in your country, covering the possibility of driving on the public highway with a front-mounted attachment on your machine.
- If road legislation in your country authorises circulation with a front-mounted attachment, you must at least:
 - Protect and report any sharp and/or dangerous edges on the attachment (≠ 4 - ADAPTABLE ATTACHMENTS AVAILABLE ON THE RANGE).
 - The attachment must not be loaded.
 - Make sure that the attachment does not mask the lighting range of the forward lights.
 - Make sure that current legislation in your country does not require other obligations.

For machines equipped with a towing system

OPERATING THE MACHINE WITH A TRAILER

- For using a trailer, observe the regulations in force in your country (maximum travel speed, braking, maximum weight of trailer, etc.).
- Do not forget to connect the trailer's electrical equipment to that of the machine.
- The trailer's braking system must comply with current legislation.
- If pulling a trailer with assisted braking, the tractor machine must be equipped with a trailer braking mechanism. In this case, do not forget to connect the trailer braking equipment to that of the machine.
- The vertical force on the towing hook must not exceed the maximum authorized by the manufacturer (consult the manufacturer's plate on your machine).
- The authorized gross vehicle weight must not exceed the maximum weight authorized by the manufacturer (consult the manufacturer's plate on your machine).

IF NECESSARY, CONSULT YOUR DEALER.

INSTRUCTIONS FOR HANDLING A LOAD

A - CHOICE OF ATTACHMENTS

- Only attachments approved by MANITOU can be used on its machines.
- Make sure the attachment is appropriate for the work to be done (◀ 4 - ADAPTABLE ATTACHMENTS AVAILABLE ON THE RANGE).
- Make sure the attachment is correctly installed and locked onto the machine carriage.
- Make sure that your machine attachments are working properly.
- Comply with the load chart limits for the machine for the attachment used.
- Do not exceed the rated capacity of the attachment.
- Never lift a load in a sling without the attachment provided for the purpose. Optional solutions are available, please consult your dealer.

B - WEIGHT OF LOAD AND CENTRE OF GRAVITY

- Before picking up a load, you must know its weight and its center of gravity.
- The load chart for your machine is valid for a load in which the longitudinal position of the center of gravity is 500 mm or 600 mm from the base of the forks (depending on the model) (Fig. B1). For loads with center of gravity exceeding this distance, contact your dealer.
- For irregular loads, determine the transverse center of gravity before any handling (Fig. B2) and set it in the longitudinal axis of the machine.

⚠ IMPORTANT ⚠

*It is forbidden to handle a load heavier than the effective capacity defined on the machine load chart.
For loads with a moving center of gravity (e.g. liquids), take account of the variations in the center of gravity in order to determine the load to be handled and be extra vigilant and careful to limit these variations as far as possible.*

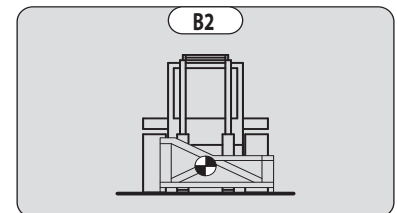
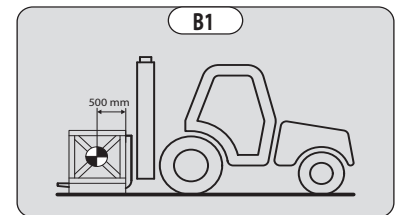

C - TRANSVERSE ATTITUDE OF THE MACHINE

- The transverse attitude is the lateral tilt of the chassis in relation to the floor.
- Raising the mast reduces the machine's lateral stability.
- The transverse attitude of the machine must be horizontal with the mast in the down position:
 - Depending on model
 - Position the machine so that the bubble in the level is between the two lines (◀ 2 - DESCRIPTION).

D - PICKING UP A LOAD ON THE GROUND

- Advance the machine perpendicular to the load, with the forks in a horizontal position (Fig. D1).
- Adjust the fork spread and centring in connection with the load (fig. D2) (optional solutions exist, consult your dealer).
- Never lift a load with a single fork.

⚠ IMPORTANT ⚠

Beware of the risks of trapping or crushing limbs when manually adjusting the forks.

- Move the machine forward slowly (1) and bring the forks up to the stop in front of the load (Fig. D3). If necessary, lift the mast slightly (2) while picking up the load.
- Bring the load into the transport position.
- Tilt the load far enough backwards to ensure stability (loss of load on braking or going downhill).

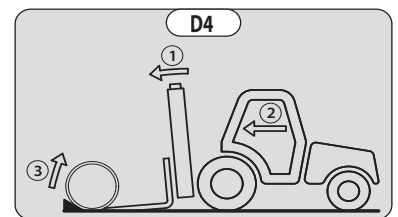
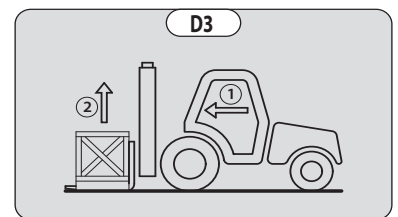
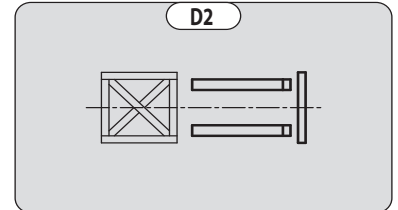
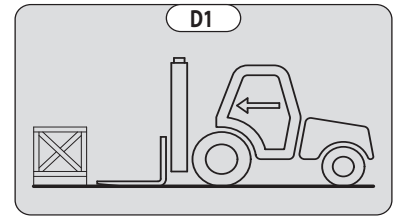

FOR A NON-PALLETIZED LOAD

- Tilt the carriage (1) forward and move the machine slowly forward (2) to insert the fork under the load (Fig. D4) (chock the load if necessary).
- Continue to move the machine (2) forward, tilting the carriage (3) (fig. D4) backward to position the load on the forks and check the load's longitudinal and lateral stability.

PICKING UP AND LAYING DOWN A HIGH LOAD ON TIRES

⚠ IMPORTANT ⚠

You must not raise the mast if you have not checked the transverse attitude of the machine (← INSTRUCTIONS FOR HANDLING A LOAD).

REMINDER: Make sure that the following operations can be performed with good visibility (← OPERATION INSTRUCTIONS UNLADEN AND LADEN).

PICKING UP A HIGH LOAD ON TIRES

- Ensure that the forks will easily pass under the load.
- Keeping the mast vertical (1), advance the machine and raise the forks to level with the load (2) (Fig. E1).
- Manoeuvre carefully and gently to bring the forks to the stop in front of the load (fig. E2). Apply the parking brake and place the forward/reverse selector in neutral.

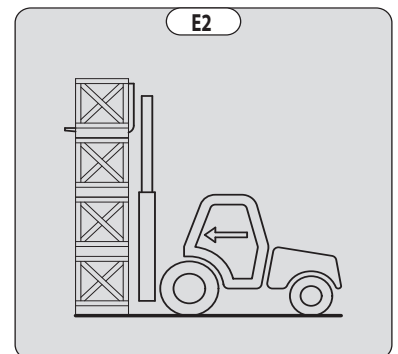
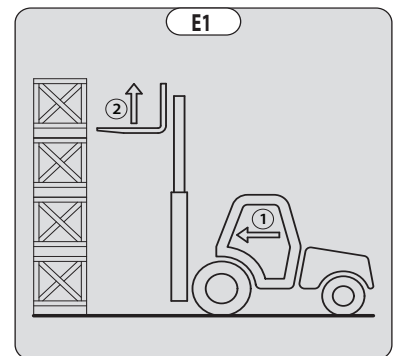

- Lift the load slightly (1) and tilt the carriage (2) backward to stabilize the load (Fig. E3).
- Tilt the load sufficiently backwards to ensure its stability.
- Reverse the machine (1) very carefully and gently to free the load. Lower the mast (2) to bring the load into transport position (fig. E4).

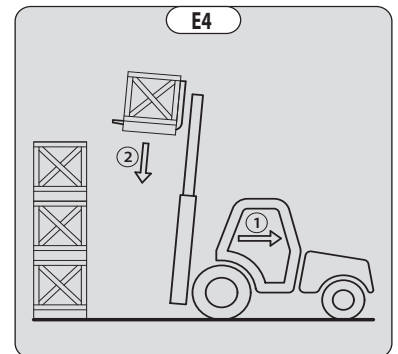
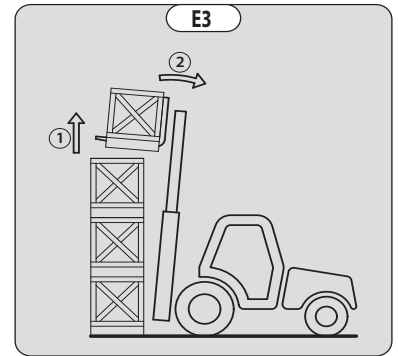

SETTING DOWN A HIGH LOAD ON TIRES

- Approach the load in the transport position in front of the pile (fig. E5).
- Raise the mast (1) until the load is higher than the pile and move the machine forward (2) (Fig. E6) very carefully and gently, until the load is over the pile. Apply the parking brake and place the forward/reverse selector in neutral.
- Place the load in a horizontal position by tilting the mast forwards (1) and lay it down on the pile (2) while checking the correct positioning of the load (fig. E7).
- Reverse the machine (1) very slowly and carefully to free the forks (Fig. E8). Then set the forks into transport position.

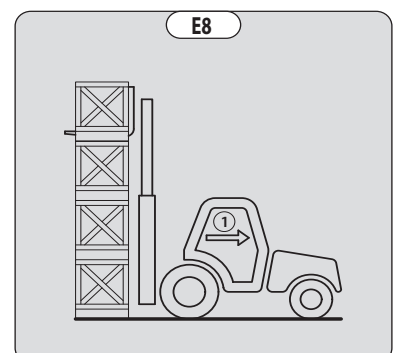
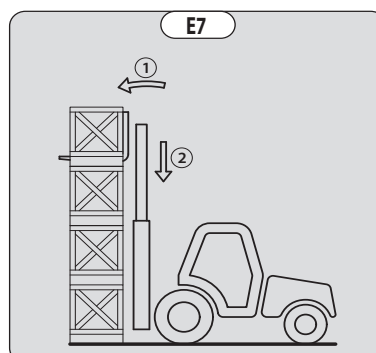
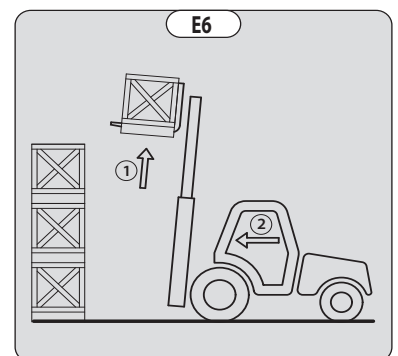
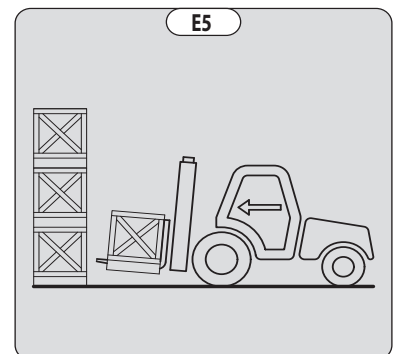



MACHINE MAINTENANCE INSTRUCTIONS

GENERAL INSTRUCTIONS

- Make sure the area is adequately ventilated before starting up the machine.
- Wear clothes suitable for the maintenance of the machine. Avoid wearing jewelry and loose clothes. Tie back and protect your hair, if necessary.
- Before doing any work on the machine:
 - Switch off the engine
 - Apply the parking brake.
 - Remove the ignition key.
- Read the operator's manual carefully.
- Carry out all repairs immediately, even if the repairs concerned are minor.
- Repair all leaks immediately, even if the leak concerned is minor.
- Ensure that process materials and of spare parts are disposed in all safely and in an ecological manner.
- Be careful of the risk of burning and splashing:
 - Exhaust
 - Radiator
 - Engine
 - Cab heating vents
 - Etc.

MAINTENANCE

- Perform the periodic service (↖ 3 - MAINTENANCE) to keep your machine in good working order. Failure to perform periodic maintenance may invalidate the contractual warranty.

MAINTENANCE LOGBOOK

- The maintenance operations carried out in accordance with the recommendations given in Part: 3 - MAINTENANCE and the other inspection, servicing or repair operations or modifications performed on the machine or its attachments should be recorded in a maintenance logbook. The entry for each operation should include the date of the work, the names of the individuals or companies having performed them, the type of operation and its frequency, if applicable. If machine elements are replaced, the part numbers of these elements shall be indicated.

LUBRICANT AND FUEL LEVELS

- Use the recommended lubricants (never use contaminated lubricants).
- Do not fill the fuel tank when the engine is running.
- Only fill up the fuel tank in areas specified for this purpose.
- Do not fill the fuel tank to the maximum level.
- Do not smoke or approach the machine with a flame when the fuel tank is open or is being filled.

HYDRAULICS

- Any work on the load handling hydraulic circuit is forbidden except for the operations described in chapter: 3 - MAINTENANCE.
- Do not attempt to loosen unions, hoses or any hydraulic component with the circuit under pressure.



*It is dangerous to change the setting or remove the **BALANCING VALVES** or **SAFETY VALVES** that may be fitted to your machine cylinders.*

*The **HYDRAULIC ACCUMULATORS** that may be fitted on your machine are pressurized units.*

Removing these accumulators and their pipework is dangerous.

Such operations must only be performed by approved personnel (consult your dealer).

ELECTRICITY

- Do not short-circuit the starter relay to start the engine. If the forward/reverse selector is not in neutral and the parking brake is not applied, the machine may suddenly start to move.
- Do not place metal items on the battery.
- Disconnect the battery before working on the electrical circuit.



WELDING

- Disconnect the battery before any welding operations on the machine.
- When carrying out electric welding work on the machine, connect the negative cable from the equipment directly to the part being welded so as to avoid very high current passing through the alternator.
- Never carry out welding or work which gives off heat on an assembled tire. The heat would increase the pressure which could cause the tire to explode.
- If the machine is equipped with an electronic control unit, disconnect it before starting to weld so as to avoid the risk of causing irreparable damage to electronic components.

WASHING THE MACHINE

- Clean the machine or at least the area concerned before any intervention.
- Remember to close and lock all accesses to the machine (doors, windows, cowls, etc.).
- During washing, avoid the articulations and electrical components and connections.
- If necessary, protect against penetration of water, steam or cleaning agents, components susceptible of being damaged, particularly electrical components and connections and the injection pump.
- Clean the machine of any traces of fuel, oil or grease.

TRANSPORTING THE MACHINE

⚠ IMPORTANT ⚠

Transporting the machine involves real risks for the operator and others involved.

- Towing, slinging or transporting the machine (< 3 - MAINTENANCE).



PROLONGED MACHINE SHUTDOWN

INTRODUCTION

⚠ IMPORTANT ⚠

Procedures to follow for long duration standstill and for bringing back the machine into service must be performed by your dealership.

This period of long duration standstill must not exceed 12 months.

After 12 months, repeat the procedures for putting the machine back into service and long-term shutdown.

The recommendations below are intended to prevent the machine from being damaged when it is not used for a period of more than 3 months.

PREPARATION OF THE MACHINE

- Clean the machine thoroughly.
- Check and repair any leakage of fuel, oil, water or air.
- Replace or repair any worn or damaged parts.
- Wash the painted surfaces of the machine in clear and cold water and wipe them.
- Touch up the paintwork if necessary.
- Shut down the machine (↩ OPERATING INSTRUCTIONS UNLADEN AND LADEN).
- Make sure the mast cylinder rods are all in retracted position.
- Release the pressure in the hydraulic circuits.

DEF (Diesel Exhaust Fluid) TANK

Depending on machine model

- Empty and rinse the "DEF" tank.
- Replace the "DEF" (Diesel Exhaust Fluid) feed pump filter (↩ 3 - MAINTENANCE).
- Fill up with new "DEF" (Diesel Exhaust Fluid) (↩ 2 - DESCRIPTION).
- Start up the machine to pressurize the circuit and bring it up to working temperature.
- Stop the engine.
- Check the "DEF" level and top up if required.

PROTECTING THE ENGINE

- Contact your dealer to obtain the procedure for protecting the inside of the engine (use of protection product).
- Fill the tank with fuel (↩ 3 - MAINTENANCE).
- Replace the coolant (↩ 3 - MAINTENANCE).
- Leave the engine running at idling speed for a few minutes, then switch off.
- Replace the engine oil and oil filter (↩ 3 - MAINTENANCE).
- Run the engine for a short time so that the oil and coolant circulate inside.
- Disconnect the battery and store it in a safe place away from the cold, after charging it to a maximum.
- Block the outlet with waterproof adhesive tape.
- Remove the drive belts and store them in a safe place.
- Disconnect the engine cut-off solenoid on the injection pump and carefully insulate the connection.

MACHINE PROTECTION

- Place the machine on level ground.
- Set the machine on axle stands so that the tires are not in contact with the ground and release the parking brake.
- Protect cylinder rods which will not be retracted from corrosion.
- Wrap the tires.

N.B.: If the machine is to be stored outdoors, cover it with a waterproof tarpaulin.



RETURNING THE MACHINE TO SERVICE

- Remove the waterproof adhesive tape from all the orifices.
- Refit and reconnect the battery.
- Remove the protection from the cylinder rods.
- Perform the daily maintenance operations (↩ 3 - MAINTENANCE).
- Perform the weekly maintenance operations (↩ 3 - MAINTENANCE).
- Put the handbrake on and remove the axle stands.
- Drain and clean the fuel tank (↩ 3 - MAINTENANCE).
- Fill the fuel tank with clean diesel filtered through the filler port.
- Replace the fuel filter (↩ 3 - MAINTENANCE).
- Replace the fuel pre-filter (↩ 3 - MAINTENANCE). (depending on machine model)
- Empty and rinse the DEF tank. (depending on machine model)
- Slowly fill the tank with new "DEF" (Diesel Exhaust Fluid) up to the bottom of the filler neck. (depending on machine model)
- Refit the drive belts and adjust the tension (↩ 3 - MAINTENANCE).
- Turn the engine over with the starter, to allow the oil pressure to rise.
- Reconnect the engine cut-off solenoid.
- Lubricate the machine completely (↩ 3 - MAINTENANCE).

⚠ IMPORTANT ⚠

Make sure the area is adequately ventilated before starting up the machine.

- Start up the machine, following the operating and safety instructions (↩ OPERATING INSTRUCTIONS UNLADEN AND LADEN).
- Carry out all the boom hydraulic movements, concentrating on the ends of travel for each cylinder.



DISPOSING OF THE MACHINE

⚠ IMPORTANT ⚠

Consult your dealer before disposing of the machine.

RECYCLING OF MATERIALS

METALS

- Metals are 100% recoverable and recyclable.

PLASTICS

- Plastic parts are identified with a marking in accordance with current regulations.
- A limited range of materials is used to simplify the recycling process.
- The majority of the plastic components are made of "thermoplastic" plastics, which are easily recycled by melting, granulating or grinding.

RUBBER

- Tires and seals can be ground for use in cement manufacture or to obtain reusable granules.

GLASS

- Glass items can be removed and collected for processing by glaziers.

ENVIRONMENTAL PROTECTION

By entrusting the maintenance of your machine to the MANITOU network, the risk of pollution is limited and the contribution to environmental protection is made.

WORN OR DAMAGED PARTS

- Do not dump them in the countryside.
- MANITOU and its network have signed-up to a scheme of environmental protection through recycling.

USED OIL

- The MANITOU network organizes the collection and processing of used oil.
- By handing over your waste oil to MANITOU, the risk of pollution is limited.

USED BATTERIES

- Do not throw away batteries, as they contain metals that are harmful for the environment.
- Return them to the MANITOU network or any other approved collection point.

N.B.: MANITOU aims to manufacture machines that provide the best performance and limit polluting emissions.



2 - DESCRIPTION





2 - DESCRIPTION

<u>"CE" DECLARATION OF CONFORMITY</u>	<u>2-4</u>
<u>UKCA DECLARATION OF CONFORMITY</u>	<u>2-6</u>
<u>SAFETY PLATES AND STICKERS</u>	<u>2-8</u>
<u>IDENTIFICATION OF THE LIFT TRUCK</u>	<u>2-12</u>
<u>SPECIFICATIONS</u>	<u>2-14</u>
<u>MAST SPECIFICATIONS AND LOAD CHARTS</u>	<u>2-16</u>
<u>TYRES</u>	<u>2-18</u>
<u>INSTRUMENTS AND CONTROLS</u>	<u>2-20</u>
<u>SLINGING PIN</u>	<u>2-40</u>



"CE" DECLARATION OF CONFORMITY

This document is a specimen of the EC declaration of conformity incorporating the contents of the original declaration supplied with the lift truck.

This specimen and the original document may contain fields that are not applicable to your lift truck. These fields are left empty if not applicable.

Refer to the original declaration of conformity for all the data applicable to your lift truck.

1) **DÉCLARATION «CE» DE CONFORMITÉ (originale)** **«EC» DECLARATION OF CONFORMITY (original)**

2) Constructeur, *Manufacturer* : **MANITOU BF**

3) Adresse, *Address* : **430, RUE DE L'AUBINIÈRE - B.P 10249
44158 - ANCENIS - CEDEX - FRANCE**

4) Titulaire du dossier technique, *Holder of the technical file* : **MANITOU BF**

3) Adresse, *Address* : **430, RUE DE L'AUBINIÈRE - B.P 10249
44158 - ANCENIS - CEDEX - FRANCE**

5) Le constructeur déclare que la machine décrite ci-après, *The manufacturer declares that the machine described below* :

Rough Terrain Counterbalanced Forklift

M70-2 H D ST5 S1 EU

6) Est conforme aux directives suivantes et à leurs transpositions en droit national (si applicables), *Complies with the following directives and their transpositions into national law (if applicable)* :

2006/42/CE

7) Pour les machines annexe IV, *For annex IV machines* : Non applicable

8) Numéro d'attestation, *Certificate number* : Non applicable

9) Organisme notifié, *Notified body* : Non applicable

2000/14/CE + 2005/88/CE

10) Procédure appliquée, *Applied procedure* : ANNEXE VIII

9) Organisme notifié, *Notified body* : TÜV SÜD INDUSTRIE SERVICE GMBH
WESTENDSTRASSE 199
80686 MUNICH - GERMANY

11) Niveau de puissance acoustique, *Sound power level* :

12) Mesuré, *Measured* : dB (A)

13) Garanti, *Guaranteed* : dB (A)

2014/30/UE

14) Normes harmonisées utilisées, *Harmonised standards used* :

EN 12895

15) Normes ou dispositions techniques utilisées, *Standards or technical provisions used* :

EN ISO 3691 + EN 16307

16) Fait à, *Done at* :

17) Date, *Date* :

18) Nom du signataire, *Name of signatory* :

19) Fonction, *Function* :

20) Société, *Company* :

21) Signature, *Signature* :



bg : 1) удостоверение за « CE » съответствие (оригинална), 2) Фирмата, 3) Адрес, 4) Техническо досие, 5) Фабрикант на описаната по-долу машина, 6) Обявява, че тази машина, 7) товара на следните директиви и на тяхното съответствие национално право, 8) За машините към допълнение IV, 9) Номер на удостоверениеето, 10) Наименувана фирма, 15) хармонизирани стандарти използвани, 16) стандарти или технически правила, използвани, 17) Изработено в, 18) Дата, 19) Име на разпсалния се, 20) Функция, 21) Функция.

cs : 1) ES prohlášení o shodě (původní), 2) Název společnosti, 3) Adresa, 4) Technická dokumentace, 5) Výrobce níže uvedeného stroje, 6) Prohlašuje, že tento stroj, 7) Je v souladu s následujícími směrnici a směrnici transponovanými do vnitrostátního práva, 8) Pro stroje v příloze IV, 9) Číslo certifikátu, 10) Notifikační orgán, 15) harmonizované normy použity, 16) Norem a technických pravidel používaných, 17) Místo vydání, 18) Datum vydání, 19) Jméno podepsaného, 20) Funkce, 21) Podpis.

da : 1) EF Overensstemmelseserklæring (original), 2) Firmaet, 3) Adresse, 4) tekniske dossier, 5) Konstruktør af nedenfor beskrevne maskine, 6) Erklærer, at denne maskine, 7) Overholder nedennævnte direktiver og disses gennemførelse til national ret, 8) For maskiner under bilag IV, 9) Certifikat nummer, 10) Bemyndigede organ, 15) harmoniserede standarder, der anvendes, 16) standarder eller tekniske regler, 17) Udfærdiget i, 18) Dato, 19) Underskrivers navn, 20) Funktion, 21) Underskrift.

de : 1) EG-Konformitätserklärung (original), 2) Die Firma, 3) Adresse, 4) Technischen Unterlagen, 5) Hersteller der nachfolgend beschriebenen Maschine, 6) Erklärt, dass diese Maschine, 7) den folgenden Richtlinien und deren Umsetzung in die nationale Gesetzgebung entspricht, 8) Für die Maschinen laut Anhang IV, 9) Bescheinigungsnummer, 10) Benannte Stelle, 15) angewandten harmonisierten Normen, 16) angewandten sonstigen technischen Normen und Spezifikationen, 17) Ausgestellt in, 18) Datum, 19) Name des Unterzeichners, 20) Funktion, 21) Unterschrift.

el : 1) Δήλωση συμμόρφωσης CE (πρωτότυπο), 2) Η εταιρεία, 3) Διεύθυνση, 4) τεχνικό φάκελο, 5) Κατασκευάστρια του εξής περιγραφόμενου μηχανήματος, 6) Δηλώνει ότι αυτό το μηχάνημα, 7) Είναι σύμφωνο με τις εξής οδηγίες και τις προσαρμογές τους στο εθνικό δίκαιο, 8) Για τα μηχανήματα παραρτήματος IV, 9) Αριθμός δήλωσης, 10) Κοινοποιημένος φορέας, 15) εναρμονισμένα πρότυπα που χρησιμοποιούνται, 16) Πρότυπα ή τεχνικούς κανόνες που χρησιμοποιούνται, 16) Είναι σύμφωνο με τα εξής πρότυπα και τεχνικές διατάξεις, 17) Έν, 18) Ημερομηνία, 19) Όνομα του υπογράφοντος, 20) Οέση, 21) Υπογραφή.

es : Declaración DE de conformidad (original), 2) La sociedad, 3) Dirección, 4) expediente técnico, 5) Constructor de la máquina descrita a continuación, 6) Declara que esta máquina, 7) Está conforme a las siguientes directivas y a sus transposiciones en derecho nacional, 8) Para las máquinas anexo IV, 9) Número de certificación, 10) Organismo notificador, 15) normas armonizadas utilizadas, 16) Otras normas o especificaciones técnicas utilizadas, 17) Hecho en, 18) Fecha, 19) Nombre del signatario, 20) Función, 21) Firma.

et : 1) EÜ vastavusdeklaratsioon (algupärane), 2) Äriühing, 3) Aadress, 4) Tehniline dokumentatsioon, 5) Seadme tööaja, 6) Kinnitab, et see toode, 7) On vastavuses järgmistele direktiivide ja nende riiigisisese õigusesse ülevõtmiseks vastuvõetud õigusaktidega, 8) IV lisa loetletud seadmete puhul, 9) Tunnistuse number, 10) Sertifitseerimisasutus, 15) kasutatud ühtlustatud standardite, 16) Muud standardites või spetsifikatsioonides kasutatakse, 17) Väljaandmise koht, 18) Väljaandmise aeg, 19) Allkirjastaja nimi, 20) Amet, 21) Allkiri.

fi : 1) EY-vaatimustenmukaisuusvakuutus (alkuperäiset), 2) Yritys, 3) Osoite, 4) teknisen eritelmän, 5) Jäljessä kuvattu koneen valmistaja, 6) Vakuuttaa, että tämä kone, 7) Täyttää seuraavien direktiivien sekä niitä vastaavien kansallisten säännösten vaatimukset, 8) Liitteen IV koneiden osalta, 9) Todistuksen numero, 10) Ilmoitettu laitos, 15) yhdenmukaistettuja standardeja käytetään, 16) muita standardeja tai eritelmiä, 17) Paikka, 18) Aika, 19) Allekirjoittajan nimi, 20) Toimi, 21) Allekirjoitus.

ga : 1) « EC »dearbhu comhréireacht (bunaidh), 2) An comhlacht, 3) Seoladh, 4) comhad teicniúil, 5) Déantóir an innill a thairiscítear thíos, 6) Dearbhaionn sé go bhfuil an t-inneall, 7) Go gclonóin sé le na teoracha seo a leanas agus a trasuimh isteach i ndlí náisiúnta, 8) Le haghaidh innill an aghuisín IV, 9) Uimhir teastais, 10) Comhlacht a chuireadh i bhfios, 15) caighdeán comchuibhithe a úsáidtear, 16) caighdeán eile nó sonraíochtaí teicniúla a úsáidtear, 17) Déanta ag, 18) Dáta, 19) Ainm an tsinitheora, 20) Feidhm, 21) Síniú.

hu : 1) CE megfelelősegi nyilatkozat (eredeti), 2) A vállalat, 3) Cím, 4) műszaki dokumentáció, 5) Az alábbi gép gyártója, 6) Kijelenti, hogy a gép, 7) Megfelel az alábbi irányelveknek valamint azok honosított előírásainak, 8) A IV. melléklet gőpeinek, 9) Bizonylati szám, 10) Ertesített szervezet, 15) felhasznált harmonizált szabványok, 16) egyéb felhasznált műszaki szabványok és előírások hivatkozásai, 17) Kelt (hely), 18) Dátum, 19) Aláíró neve, 20) Funkció, 21) Aláírás.

is : 1) Samræmisvottorð ESB (upprunalega), 2) Fyrirtækið, 3) Aðsetur, 4) Tæknilegar skrá, 5) Smiður tækisins sem lýst er hér á eftir, 6) Staðfestir að tækið, 7) Samræmist eftirfarandi stöðlum og staðfarlu þeirra með hljóðun af þjóðarrétti, 8) Fyrir tækin í aukakafli IV, 9) Staðfestingarnúmer, 10) Tilkynnt til, 15) samhæfða staða sem notaðir, 16) önnur staðlar eða forskriftir notað, 17) Staður, 18) Dagsetning, 19) Nafn undirritaðs, 20) Staða, 21) Undirskrift.

it : 1) Dichiarazione CE di conformità (originale), 2) La società, 3) Indirizzo, 4) fascicolo tecnico, 5) Costruttore della macchina descritta di seguito, 6) Dichiara che questa macchina, 7) È conforme alle direttive seguenti e alle relative trasposizioni nel diritto nazionale, 8) Per le macchine Allegato IV, 9) Numero di Attestazione, 10) Organismo notificato, 15) norme armonizzate applicate, 16) altre norme e specifiche tecniche applicate, 17) Stabilità a, 18) Data, 19) Nome del firmatario, 20) Funzione, 21) Firma.

lt : 1) CE atitikties deklaracija (originalas), 2) Bendrovė, 3) Adresas, 4) Techninė byla, 5) Žemiau nurodytas įrenginio gamintojas, 6) Pareiškia, kad šis įrenginys, 7) Atitinka toliau nurodytas direktyvas ir į nacionalinius teisės aktus perkeltas jų nuostatas, 8) IV priedas dėl mašinų, 9) Certifikato Nr., 10) Paskelbtoji įstaiga, 15) suderintus standartus naudojamus, 16) Kiti standartai ir techninės specifikacijos, 17) Pasirašyta, 18) Data, 19) Pasirašiusio asmens vardas ir pavardė, 20) Pareigos, 21) Parašas.

lv : 1) EK atbilstības deklarācija (oriģināls), 2) Uzņēmums, 3) Adrese, 4) Tehniskās lietas, 5) Tālāk aprakstītās iekārtas ražotājs, 6) Apliecinā, ka šī iekārta, 7) Ir atbilstoša tālāk norādītajām direktīvām un to transpozīcijai nacionālajā likumdošanā, 8) Iekārtām IV pielikumā, 9) Apliecināš numurs, 10) Reģistrētā organizācija, 15) lietotajiem saskaņotajiem standartiem, 16) lietotajiem tehniskajiem standartiem un specifikācijām, 17) Sastādīts, 18) Datums, 19) Parakstītāja vārds, 20) Amats, 21) Paraksts.

mt : 1) Dikjarazzjoni ta' Konformità KE (oriġinali), 2) Il-kumpanija, 3) Indirizz, 4) fajl tekniku, 5) Manifattriċi tal-magna deskritta hawn isfel, 6) Tiddikjara li din il-magna, 7) Hija konformi hija konformi mad-Direttivi segwenti u l-Igijiet li jimplimentawhom fil-Igji nazzjonali, 8) Għall-magni fl-Anness IV, 9) Numru taċ-certifikat, 10) Entità notifikata, 15) l-istandards armonizzati użati, 16) standards tekniċi u specifikazzjonijiet oħra użati, 17) Magħmul f', 18) Data, 19) Isem il-firmatarju, 20) Kariga, 21) Firma.

nl : 1) EG-verklaring van overeenstemming (oorspronkelijke), 2) Het bedrijf, 3) Adres, 4) technisch dossier, 5) Constructeur van de hierna genoemde machine, 6) Verklaart dat deze machine, 7) In overeenstemming is met de volgende richtlijnen en hun omzettingen in het nationale recht, 8) Voor machines van bijlage IV, 9) Goedgekeuringsnummer, 10) Aangezegde instelling, 15) gehanteerde geharmoniseerde normen, 16) andere gehanteerde technische normen en specificaties, 17) Opgemaakt te, 18) Datum, 19) Naam van ondergetekende, 20) Functie, 21) Handtekening.

no : 1) CE-samsvarserklæring (original), 2) Selskapet, 3) Adresse, 4) tekniske arkiv, 5) Fabrikant av følgende maskin, 6) Erklærer at denne maskinen, 7) Oppfyller kravene i følgende direktiver, med nasjonale gjennomføringsbestemmelser, 8) For maskinene i tillegg IV, 9) Attestnummer, 10) Notifisert organ, 15) harmoniserede standarder som brukes, 16) Andre standarder og spesifikasjoner brukt, 17) Utstedt i, 18) Dato, 19) Underskrivers navn, 20) Stilling, 21) Underskrift.

pl : 1) Deklaracja zgodności CE (oryginalne), 2) Spółka, 3) Adres, 4) dokumentacja techniczna, 5) Wykonawca maszyny opisanej poniżej, 6) Oświadczca, że ta maszyna, 7) Jest zgodna z następującymi dyrektywami i odpowiedziami przepisami prawa krajowego, 8) Dla maszyn załącznik IV, 9) Numer certyfikatu, 10) Jednostka certyfikująca, 15) zastosowanych norm zharmonizowanych, 16) innych zastosowanych norm technicznych i specyfikacji, 17) Sporządzono w, 18) Data, 19) Nazwisko podpisującego, 20) Stanowisko, 21) Podpis.

pt : 1) Declaração de conformidade CE (original), 2) A empresa, 3) Morada, 4) processo técnico, 5) Fabricante da máquina descrita abaixo, 6) Declara que esta máquina, 7) Está em conformidade às diretivas seguintes e às suas transposições para o direito nacional, 8) Para as máquinas no anexo IV, 9) Número de certificado, 10) Entidade notificada, 15) normas harmonizadas utilizadas, 16) outras normas e especificações técnicas utilizadas, 17) Elaborado em, 18) Data, 19) Nome do signatário, 20) Cargo, 21) Assinatura.

ro : 1) Declarație de conformitate CE (originală), 2) Societatea, 3) Adresa, 4) cărți tehnice, 5) Constructor al mașinii descrise mai jos, 6) Declară că prezenta mașină, 7) Este conformă cu directivele următoare și cu transpunerea lor în dreptul național, 8) Pentru mașinile din anexa IV, 9) Număr de atestare, 10) Organism notificat, 15) standardele armonizate utilizate, 16) alte standarde și specificații tehnice utilizate, 17) Intocmit la, 18) Data, 19) Numele persoanei care semnează, 20) Funcția, 21) Semnătura.

sk : 1) ES vyhlásenie o zhode (pôvodný), 2) Názov spoločnosti, 3) Adresa, 4) technickej dokumentácie, 5) Výrobca nižšie opísaného stroja, 6) Vyhlasuje, že tento stroj, 7) Je v súlade s nasledujúcimi smernicami a smernicami transponovanými do vnútroštátneho práva, 8) Pre stroje v prílohe IV, 9) Číslo certifikátu, 10) Notifikačný orgán, 15) použité harmonizované normy, 16) použité iné technické normy a predpisy, 17) Miesto vydania, 18) Dátum vydania, 19) Meno podpisujúceho, 20) Funkcia, 21) Podpis.

sl : 1) ES Izjava o ustreznosti (izvirna), 2) Družba, 3) Naslov, 4) tehnične dokumentacije, 5) Proizvajalec tukaj opisanega stroja, 6) Izjavlja, da je ta stroj, 7) Ustreza naslednjim direktivam in njihovi transpoziciji v državno pravo, 8) Za stroje priloga IV, 9) Številka potrdila, 10) Obvestilo organu, 15) uporabljene harmonizirane standarde, 16) druge uporabljene tehnične standarde in zahteve, 17) V, 18) Datum, 19) Ime podpisnika, 20) Funkcija, 21) Podpis.

sv : 1) CE-försäkran om överensstämmelse (original), 2) Företaget, 3) Adress, 4) tekniska dokumentationen, 5) Konstruktör av nedan beskrivna maskin, 6) Försäkrar att denna maskin, 7) Överensstämmer med nedanstående direktiv och införlivandet av dem i nationellt rätt, 8) För maskinerna i bilaga IV, 9) Nummer för godkännande, 10) Organism som underrättats, 15) Harmoniserade standarder som använts, 16) andra tekniska standarder och specifikationer som använts, 17) Upprättat i, 18) Datum, 19) Namn på den som undertecknat, 20) Befattning, 21) Namnteckning.



UKCA DECLARATION OF CONFORMITY

This document is a specimen of the UKCA Declaration of Conformity incorporating the contents of the original declaration supplied with the lift truck.

This specimen and the original document may contain fields that are not applicable to your lift truck. These fields are left empty if not applicable.

Refer to the original declaration of conformity for all the data applicable to your lift truck.

UKCA DECLARATION OF CONFORMITY

Manufacturer: **MANITOU BF**
 Address: **430, RUE DE L'AUBINIÈRE - BP 10249
 44158 ANCENIS CEDEX - FRANCE**
 Authorized representative: **MANITOU UK
 Ebblake Industrial Estate - Dorset BH 31 6BB
 Verwood - United Kingdom**

The manufacturer declares that the below described machinery:

**Rough Terrain Counterbalanced Forklift
 M70-2 H D ST5 S1 EU**

Complies with the following legislation:

The supply of Machinery (Safety) Regulations 2008, as amended

The machine is designed for the lifting of persons:

Applied procedure: Non applicable
 Certificate number: Non applicable
 Dated:
 Approved body: Non applicable

**Noise Emission in the Environment by Equipment
 for use Outdoors Regulations 2001, as amended**

Applied procedure: Schedule 11
 Approved body: TÜV SÜD INDUSTRIE SERVICE GMBH
 WESTENDSTRASSE 199
 80686 MUNICH - GERMANY

Sound power level:

Measured: dB (A)
 Guaranteed: dB (A)

Electromagnetic Compatibility Regulations 2016, as amended

The following designated standards have been addressed:

EN 12895

The following standards or technical guidance have been addressed:

EN ISO 3691 + EN 16307

At: Date:

Name of signatory:

Position:

Company:

Signature:





SAFETY PLATES AND STICKERS

⚠ IMPORTANT ⚠

Clean all stickers and safety plates so that they are legible.
Any safety plates and stickers which are illegible or damaged must be replaced.
Check that stickers and safety plates are present after replacing any spare parts.

EXTERNAL PLATES AND STICKERS

ITEM	PART NO.	DESCRIPTION
1	288174	- Accumulator Instructions
2	24653	- Slings point
3	52563320	- Anchorage point
4	305405	- Fuel instruction
5	307508	- Battery cut-off instruction
6	52596451	- Overall height (Option)
7	52669553	- Air conditioning (Option)
8	233088	- Engine block heater (Option)

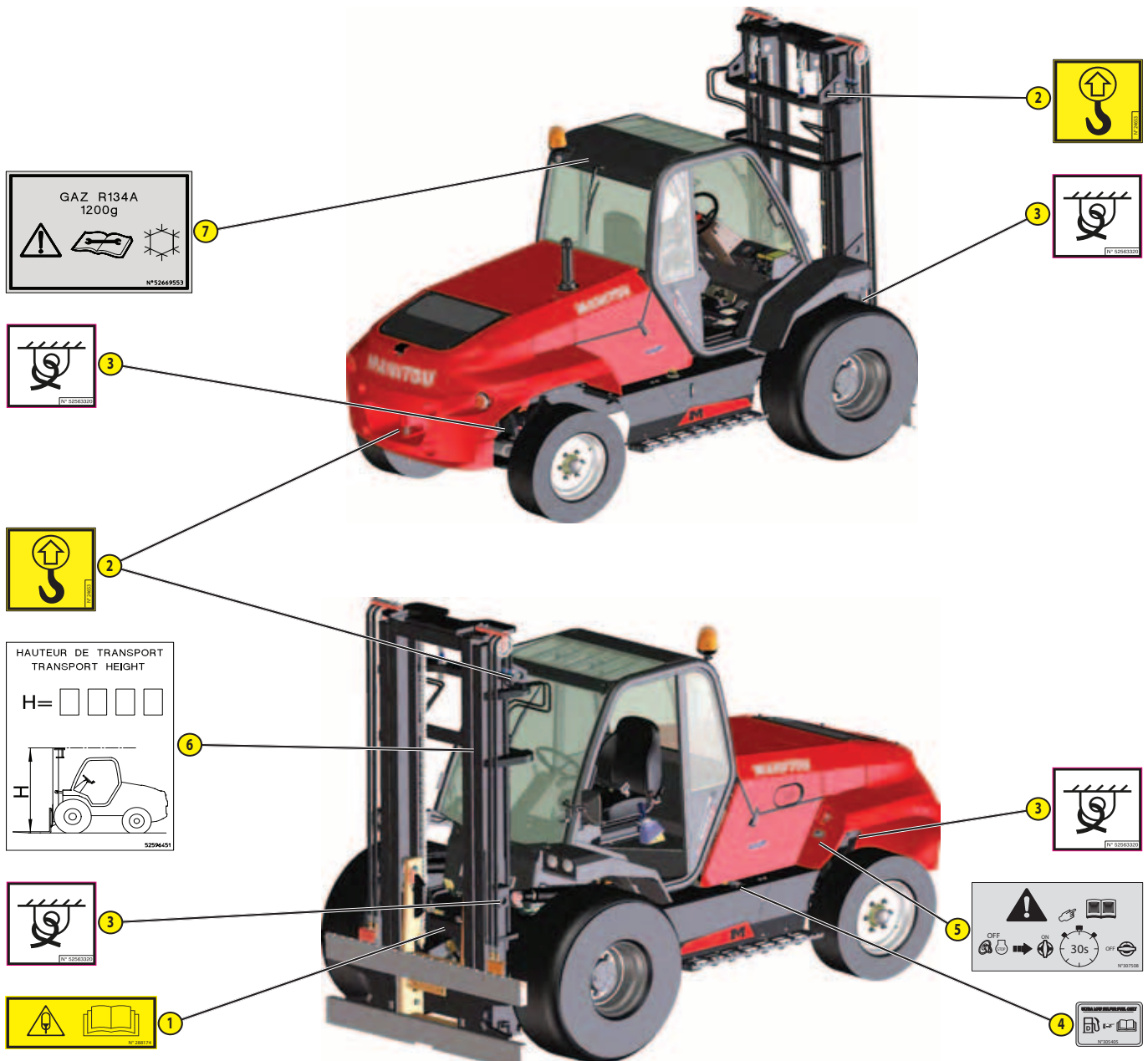



STICKERS AND PLATES IN THE CAB

ITEM	PART NO.	DESCRIPTION
1	300681	- Safety instruction
2	234806	- Differential lock instruction
3	239594	- Sound power 104 dB
4	172385	- Towing forbidden
5	76571	- Reversing shift (first version)
6	200042	- Joystick function (first version)
7	52776144	- Joystick function + reversing shift (second version)
8	52691835	- Attachment line AUX.1/AUX.2 (Option) M26-2 ... / M26-4 ... / M30-2 ... / M30-4 ...
9	203792	- Joystick function (Option)
10	203791	- Joystick function (Option)
11	203928	- Joystick function (Option)
12	203929	- Joystick function (Option)
13	268491	- Brake fluid instruction
14	52549319	- Safety instruction "DPF"
15	52678586	- Regeneration instructions
16	52533151	- Door unlocking instruction (Option)
17	304478	- Lubrication instructions
18	309444	- Fuses and relays in cab (first version)
	52807017	- Fuses and relays in cab (second version)
20	52759172	- WARNING risk of incorrect use (United Kingdom only)

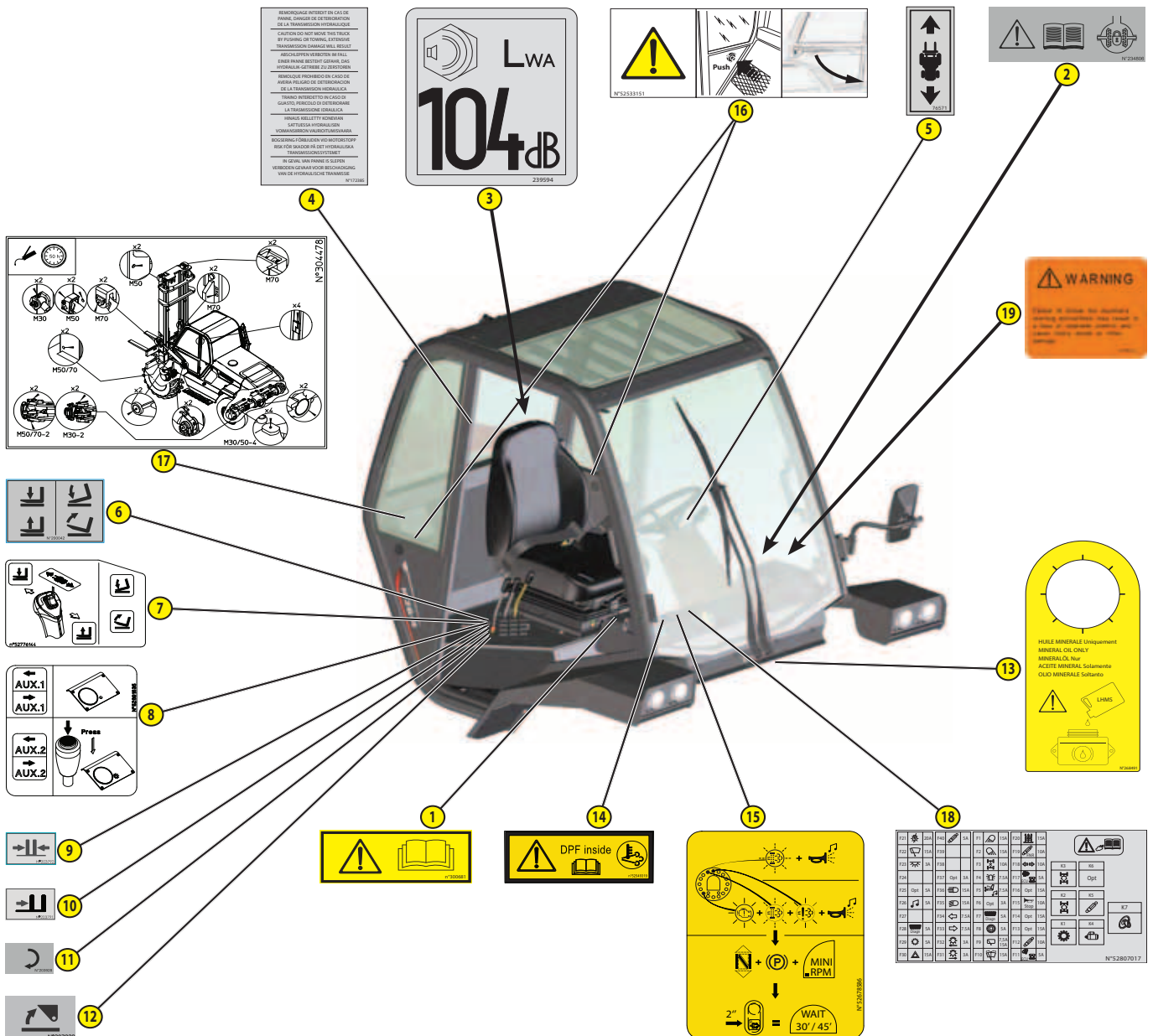



STICKERS AND PLATES UNDER THE ENGINE HOOD

ITEM	PART NO.	DESCRIPTION
1	293887	- Anti-freeze
2	259398	- Water / diesel separator
3	716906	- Fan hazard
4	233088	- Engine block heater (Option) (first version)
5	52806826	- Fuses and relays under engine cover

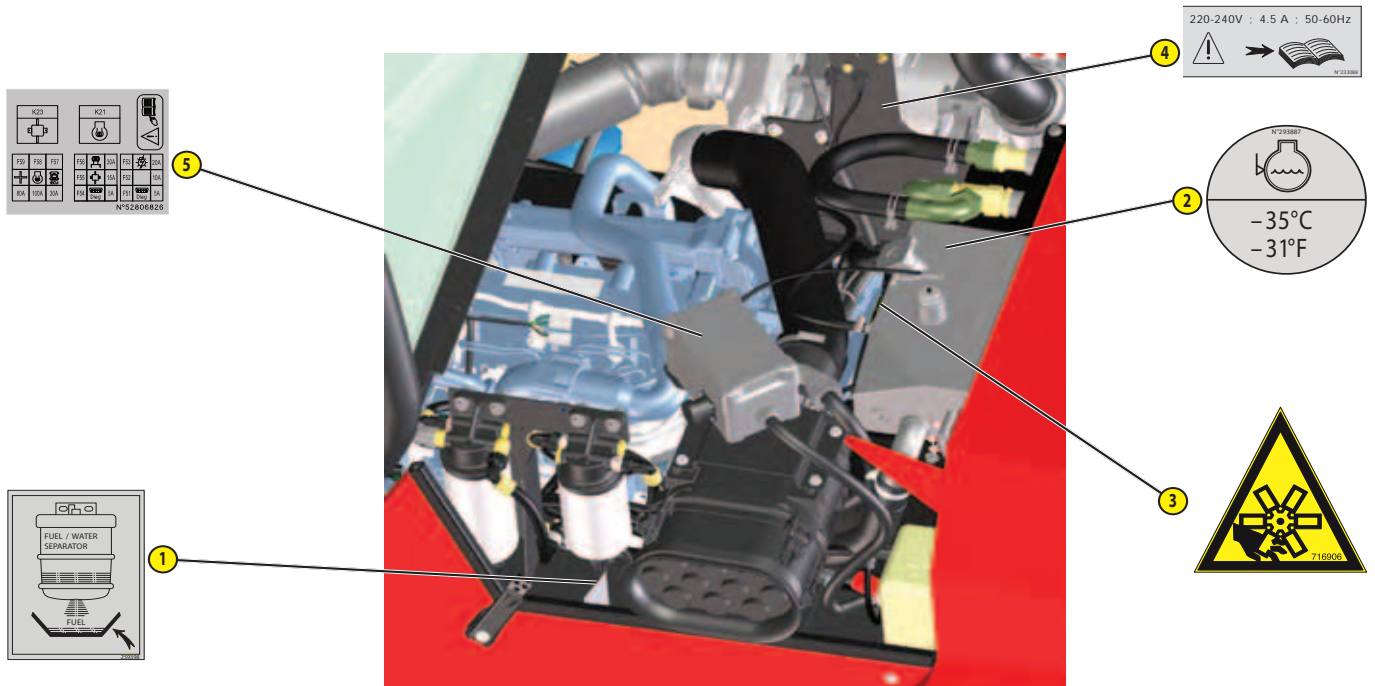





IDENTIFICATION OF THE LIFT TRUCK

As our policy is to promote a constant improvement in our products, our range of lift trucks may undergo certain modifications, without any obligation for us to advise our customers.

When you order parts, or when you require any technical information, always specify the following information.

NB: To be able to communicate these numbers more easily, we recommend writing them in the places provided upon receipt of the lift truck.

For any further technical information regarding your lift truck refer to: SPECIFICATIONS.

LIFT TRUCK MANUFACTURER'S PLATE

"Designation" Designation	
"Series" Series	
"Year of manufacture" Year of manufacture	
"Model year" Model year	
"Serial Number / Product Identification Number" Serial number/Product identification number	
"Unladen mass" Unladen weight	
"Power" Power	
"Authorized gross vehicle weight" Authorised gross vehicle weight	
"Rated capacity" Rated capacity	
"Max vertical force (on trailer hook)" Maximum vertical force (on trailer hook)	
"Drag strain" Pulling force	



VENTILATION FILTER

"MODEL" Model	
"SER.NO" Serial number	
"CODE" Supplier code	
"SPEC" Specification	
"CSPEC" Specification code	

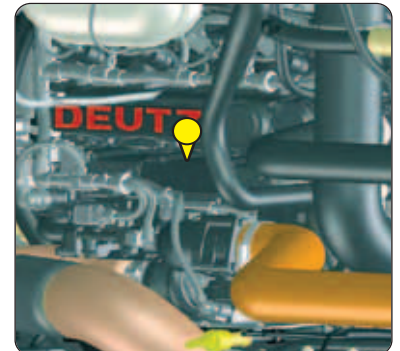

REDUCTION GEARBOX

Type	
Serial number	
Part no. MANITOU	



HYDROSTATIC PUMP

"CNR" MANITOU Part No.	
"TYP" Codification	
"MNR" Manufacturing number	
"SN" Serial number	
"FD" Date of manufacture	





HYDROSTATIC MOTOR

"CNR" MANITOU Part No.	
"TYP" Codification	
"MNR" Manufacturing number	
"SN" Serial number	
"FD" Date of manufacture	



FRONT AXLE

Type	
Serial number	
Part no. MANITOU	



OVERHEAD GUARD

CAB (OPTION)

"Constructeur" Manufacturer	
"Type Cabine" Cab type	
"N° de série" Serial number	

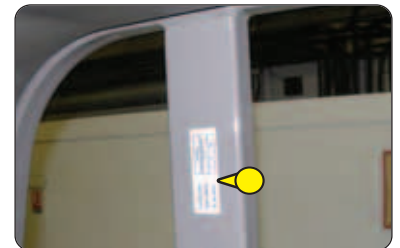

MASTS WITH ROLLERS

Part no. MANITOU	
------------------	--



CHASSIS

Serial number/Product identification number	
---	--

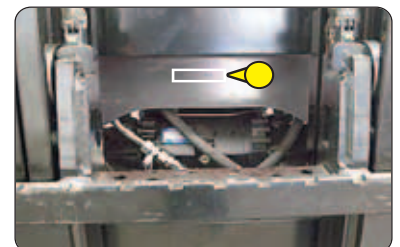

ATTACHMENT MANUFACTURER'S PLATE

"MODELE" Model	
"N° série" Serial number	
"Année Fabrication" Year of manufacture	
"Masse à vide" Unladen weight	
"Centre de gravité" Centre of gravity	
"Capacité Nominale" Rated capacity	
"Pression service" Working pressure	

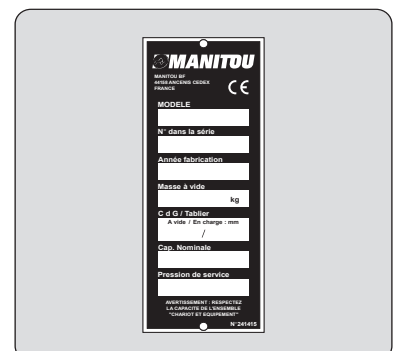



SPECIFICATIONS

NB: The specifications given are not binding on the manufacturer and can be modified without prior notification.

DESIGNATION	1.1	-Manufacturer		MANITOU
	1.2	-Model type		M70-2 HD ST5 S1 EU
	1.3	-Propulsion: battery, diesel, petrol, LPG, mains		Diesel
	1.4	-Type of operation: manual, pedestrian, standing, seated		Seated
	1.5	-Rated capacity/load on forks (basic capacity)	Q (t)	7
	1.6	-Centre of gravity of load	c (mm)	600
	1.8	-Distance from the load bearing surface to the centre of the front axle	x (mm)	803
	1.9	-Wheelbase	y (mm)	2493
	WEIGHT	2.1	-Weight of truck in working order	kg
2.2		-Front axle load laden	kg	14954
2.2.1		-Rear axle load laden	kg	1926
2.3		-Front axle load unladen	kg	4040
2.3.1		-Rear axle load unladen	kg	5840
RUNNING CARRIAGE	3.1	-Tyre equipment (bandage "V", super-elastic "SE", pneumatic "L")		L
	3.2	-Size of front wheels	" or mm	18R19,5 8T N 20 XF
	3.3	-Size of rear wheels	" or mm	265/70R19.5 6T P30 HT3
	3.5	-Number of front wheels (x = drive wheel)		2
	3.5.1	-Number of rear wheels (x = drive wheel)		2
	3.6	-Front track (middle of wheels)	b10 (mm)	1700
	3.7	-Rear track (middle of wheels)	b11 (mm)	1545
DIMENSIONS	4.1	-Tilt of mast forward	α (°)	15
	4.1.1	-Tilt of mast backward	β (°)	15
	4.2	-Height of mast lowered	h1 (mm)	3345
	4.3	-Normal free lift	h2 (mm)	0
	4.4	-Lift height	h3 (mm)	4000
	4.5	-Height of extended mast	h4 (mm)	5360
	4.7	-Height of standard/cab overhead guard	h6 (mm)	2475
	4.7	-Height of lowered overhead guard (OPTION)	h6 *(mm)	-
	4.7	-Height of air-conditioned cab (OPTION)	h6 **(mm)	2475
	4.8	-Height of seat	h7 (mm)	1485
	4.12	-Height of towing coupling	h10 (mm)	690
	4.19	-Total length	l1 (mm)	5700
	4.20	-Length of forks at heel	l2 (mm)	4200
	4.21	-Overall width	b1 (mm)	2155
	4.22	-Section of fork arms	s (mm)	70
	4.22.1	-Width of fork arms	e (mm)	150
	4.22.2	-Length of fork arms	l (mm)	1500
	4.23	-Forks carriage (in accordance with standard DIN 15173 A/B)		FEM 4
	4.24	-Width of forks carriage (with load backrest)	b3 (mm)	1750
	4.31	-Ground clearance of mast unladen	m1 (mm)	300
4.32	-Ground clearance at centre of wheel-base unladen	m2 (mm)	410	
4.33	-Aisle width for 1000x1200 pallet widthways	Ast (mm)	6703	
4.34	-Aisle width for 800x1200 pallet widthways	Ast (mm)	6703	
4.35	-Turning radius	Wa (mm)	4200	
4.36	-Inner turning radius	b13 (mm)	1000	
PERFORMANCE	5.1	-Speed of travel laden	km/h	11
	5.1.1	-Speed of travel unladen	km/h	23
	5.2	-Speed of rise laden	m/s	0,32
	5.2.1	-Speed of rise unladen	m/s	0,32
	5.3	-Speed of lowering laden	m/s	0,4
	5.3.1	-Speed of lowering unladen	m/s	0,34
	5.5	-Nominal towing power laden	daN	8700
	5.7	-Slope laden	%	45
	5.7.1	-Slope unladen	%	27
	5.9	-Acceleration time laden	s	-
	5.9.1	-Acceleration time unladen	s	-
5.10	-Service brake		Hydraulic power brake	



ENGINE	7.1	-Engine manufacturer/Type		DEUTZ TD 3,6
	7.2	-Engine power (standard ISO 1585)	kW	55,4
	7.3	-Rated speed	rpm	2500
	7.3.1	-Maximum speed	rpm	3200
	7.4	-Number of pistons/Capacity	cm ³	4
	7.5	-Fuel consumption (according to VDI cycle)	L/h	7,3
	7.6	-CO ₂ emissions	kg/h	19,1
MISCELLANEOUS	8.1	-Speed control		Electric
	8.2	-Working hydraulic pressure for attachments	Bar	230
	8.3	-Oil flow rate for attachments	L/min	80
	8.4	-Sound level in driver's ears (standard DIN 12053)	dB (A)	78
	8.4	-Sound pressure level ensured in the LwA environment (according to Directive 2000/14/EC modified by Directive 2005/88/EC)	dB (A)	104

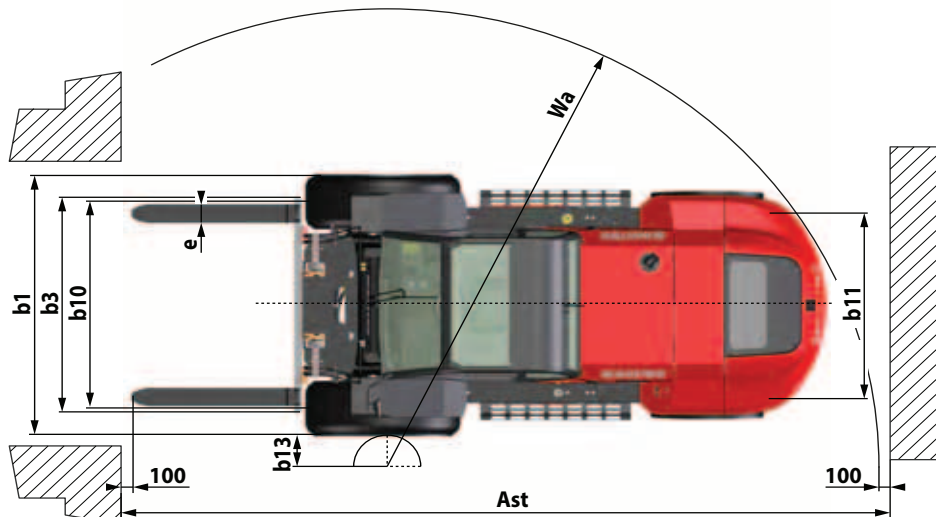
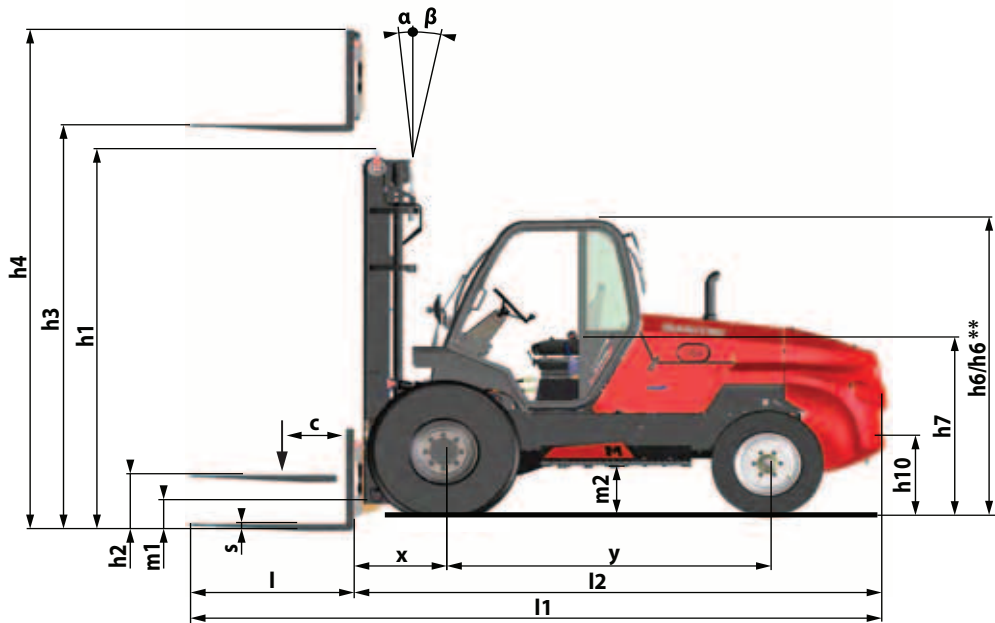

MAST SPECIFICATIONS AND LOAD CHARTS

	MAST	LIFT HEIGHT h3 (mm)	FREE LIFT h2 (mm)	HEIGHT OF MAST		TILTING			
						STANDARD		OPTION	
						α (°)	β (°)	α (°)	β (°)
DUPLEX TOTAL VISIBILITY	3M60	3600	-	3145	4960	15	15	-	-
	4M00	4000	-	3345	5360	15	15	-	-
	4M50	4500	-	3595	5860	15	15	-	-

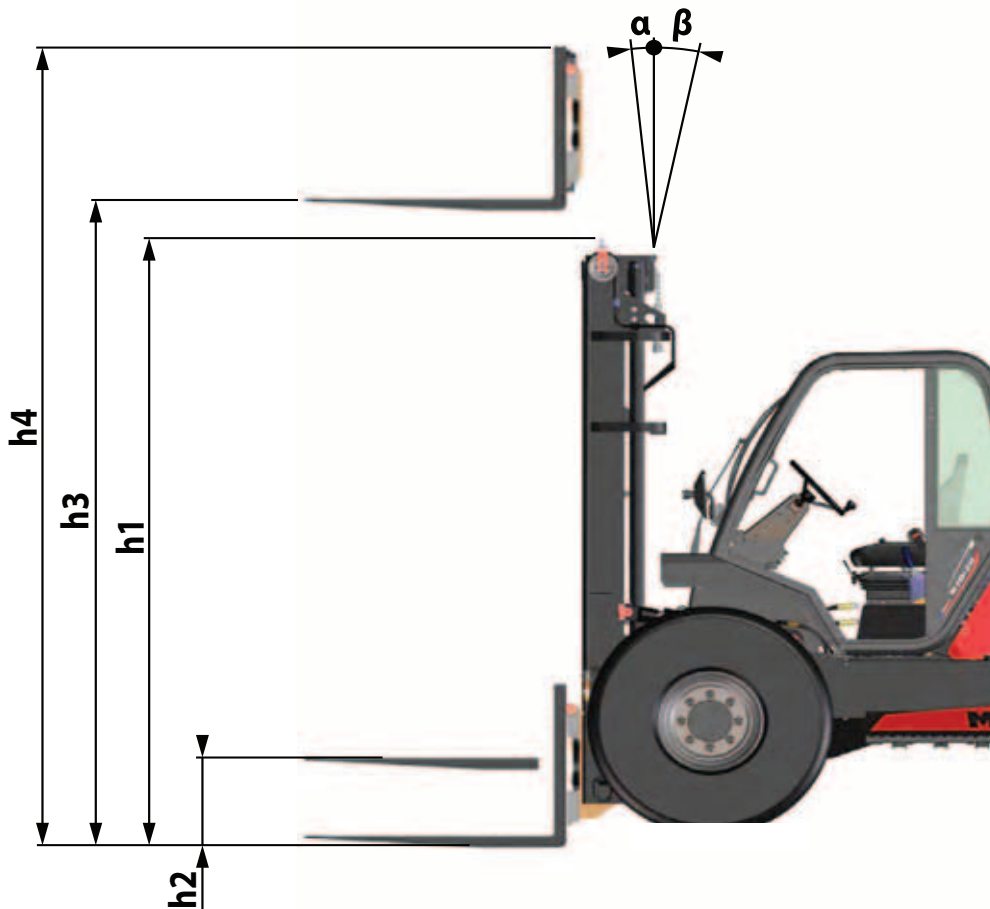



	VALUES ON FORKS		VALUES WITH INTEGRATED SIDE-SHIFT CARRIAGE	
	Height at max. capacity (mm)	Capacity at maximum height D = 600mm (kg)	Height at max. capacity (mm)	Capacity at maximum height D = 600mm (kg)
	3600	7000	-	-
	4000	7000	-	6350
	4000	5000	-	3850

RATED CAPACITY →

CAPACITE NOMINALE
RATED CAPACITY
NENNKAPAZITÄT
CAPACIDAD NOMINAL
CAPACITÀ NOMINALE

kg

ACTUAL CAPACITIES (according to standard ISO 3691-1 / ISO 22915-13) →

CAPACITES EFFECTIVES
ACTUAL CAPACITIES
EFFEKTIVE KAPAZITÄT
CAPACIDAD EFECTIVA
CAPACITÀ EFFETTIVA

SUIVANT NORME ISO 3691-1

Up to lift height →

1 - Jusqu'à hauteur de levée
Up to height of
Bis zur hubhöhe
Hasta altura de elevación
Sino ad altezza di sollevamento

mm

For maximum height of →

2 - Pour hauteur maximale de
For maximum height of
Für maximale Höhe
Para altura máxima de
Per altezza massima di

mm

VERTICAL MAST →

MAT VERTICAL
VERTIKALER MAST
MASTIL VERTICAL
RAMPA VERTICALE

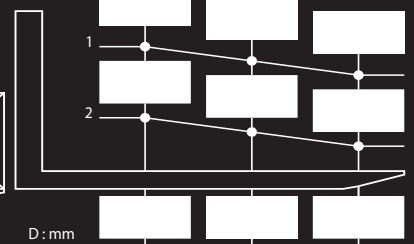
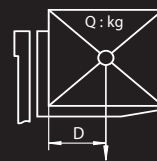

EQUIPMENT →

EQUIPEMENT
ATTACHMENT
ZUBEHÖR
EQUIPO
ATTREZZATURA

<input type="text"/>
<input type="text"/>
<input type="text"/>

ACTUAL CAPACITIES →

CAPACITES EFFECTIVES
ACTUAL CAPACITIES
EFFEKTIVE KAPAZITÄT
CAPACIDAD EFECTIVA
CAPACITÀ EFFETTIVA

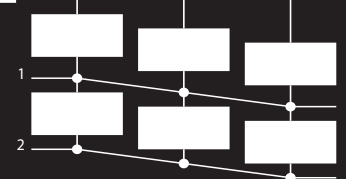

n°:



TYRES

		PRESSURE (bar)	LOAD PER TYRE (kg)			
			FRONT UNLADEN	FRONT LADEN	REAR UNLADEN	REAR LADEN
MICHELIN	18R19,5 XF TL	7	2000	7500		
	18R22,5 XF TL	7,5				
CONTINENTAL	265/70R19,5 HT3 143/141K	8			2900	950

		PRESSURE (bar)	LOAD (kg)	GROUND CONTACT PRESSURE (kg/cm ²)		GROUND CONTACT AREA (cm ²)	
				HARD GROUND	SOFT GROUND	HARD GROUND	SOFT GROUND
MICHELIN	18R19,5 XF TL	7	2000				
			7500				
	18R22,5 XF TL	7,5	2000				
			7500				
CONTINENTAL	265/70R19,5 HT3 143/141K	8	950				
			2900				





INSTRUMENTS AND CONTROLS

NB: All the terms such as: RIGHT, LEFT, FRONT, REAR are as seen by an observer occupying the driver's seat and looking straight ahead.

1 - DRIVER'S CAB ACCESS	2-22
2 - DRIVER'S SEAT	2-22
3 - SEAT BELT	2-23
4 - IGNITION SWITCH	2-24
5 - EMERGENCY STOP (Option)	2-24
6 - BATTERY CUT-OFF	2-25
7 - IDENTIFICATION KEYPAD "EasyMANAGER" (Option)	2-25
8 - DASHBOARD HANDSET	2-26
9 - SWITCHES	2-30
10 - LIGHTING, HORN AND INDICATOR SWITCH (Depending on model)	2-31
11 - DIAGNOSTIC PLUG	2-31
12 - ACCELERATOR PEDAL	2-32
13 - SERVICE BRAKE PEDAL AND TRANSMISSION CUT-OFF	2-32
14 - DIFFERENTIAL LOCK PUSHBUTTON	2-32
15 - GEAR SELECTOR	2-32
16 - PARKING BRAKE	2-32
17 - FORWARD/NEUTRAL/REVERSE GEAR SELECTION	2-33
18 - HYDRAULIC CONTROLS	2-34
19 - LOAD CHARTS	2-34
20 - LEVEL INDICATOR	2-34
21 - HEATER CONTROL (Option)	2-35
22 - WINDSCREEN DEMISTER AND HEATING VENTS (Option)	2-35
23 - AIR CONDITIONING CONTROL (Option)	2-35
24 - AIR CONDITIONING VENTS (Option)	2-35
25 - STEERING WHEEL ADJUSTMENT LEVER (Option)	2-35
26 - DOOR OPENING HANDLES (Option)	2-36
27 - DOOR UNLOCKING SWITCHES (Option)	2-36
28 - STORAGE NET	2-36
29 - WATERPROOF DOCUMENT-HOLDER (Option)	2-36
30 - ROOF LIGHT	2-36
31 - SUN VISOR (Option)	2-37
32 - INTERNAL REAR-VIEW MIRROR (Option)	2-37
33 - EXTERIOR REAR-VIEW MIRRORS	2-37
34 - FRONT HEADLIGHTS	2-37
35 - REAR LIGHTS	2-37
36 - FRONT WORKLIGHTS (Option)	2-38
37 - REAR WORKLIGHTS (Option)	2-38
38 - ROTATING BEACON LIGHT (Option)	2-38
39 - FLASHING LIGHT (Option)	2-38
40 - ENGINE BLOCK HEATER (Option)	2-39
41 - FUEL TANK	2-39
42 - FUSES AND RELAYS	2-39

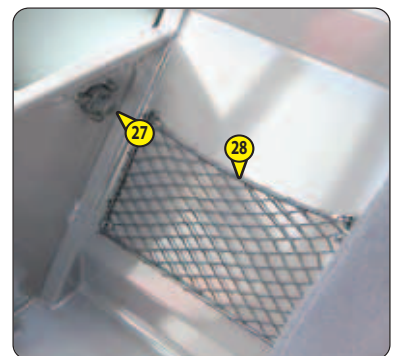
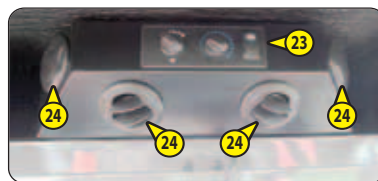
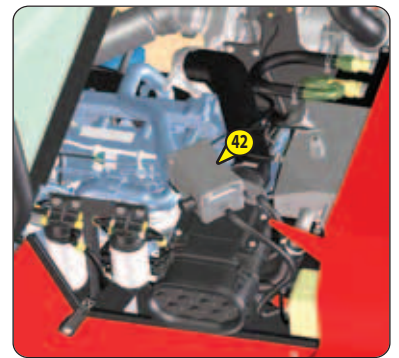
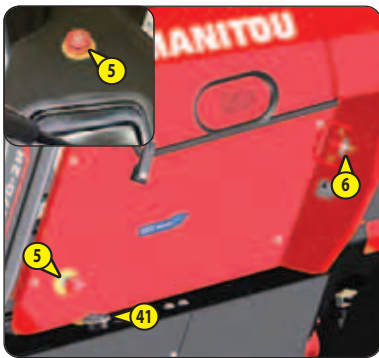
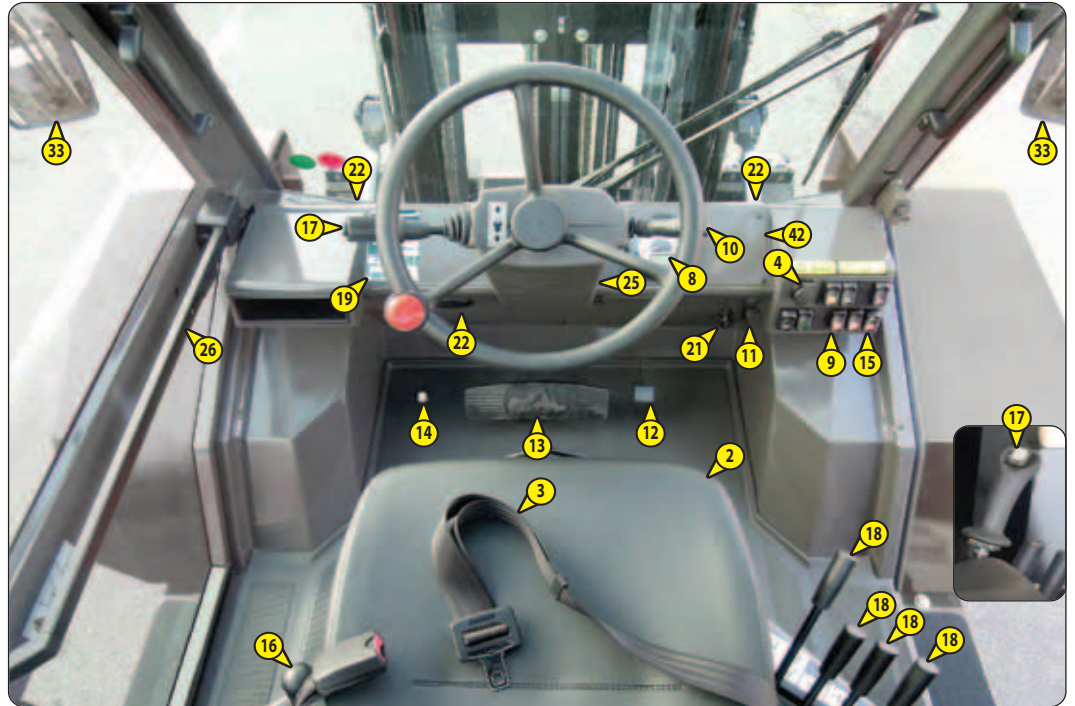
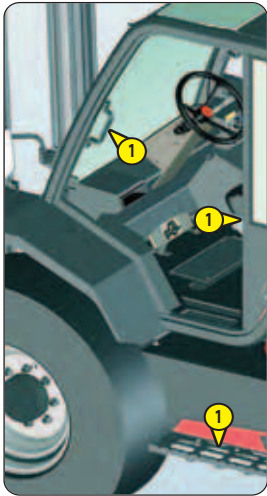

1 - DRIVER'S CAB ACCESS

- Face the driver's cab access to get in and out, and always use the three support points provided for this purpose.
 - 1 - Left handle.
 - 2 - Driver's cab pillar.
 - 3 - Step.

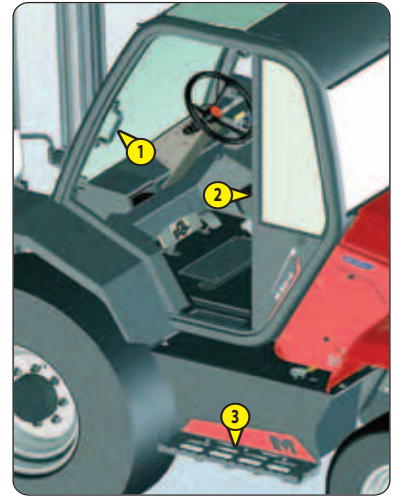

2 - DRIVER'S SEAT

DRIVER'S SEAT IN SKAI (Standard)

DRIVER'S SEAT IN FABRIC (Option)

For increased comfort, adjust the seat to your requirements for the correct position in the driver's cab.

LONGITUDINAL ADJUSTMENT

- Pull the lever 1, then slide the seat to the desired position.
- Release the lever and be sure it returns to the lock position.

SEAT HEIGHT ADJUSTMENT (first version only)

- Sit down correctly in the seat.
- Turn the knob 2 according to the desired height, clockwise to raise, anti-clockwise to lower.

SOFTNESS ADJUSTMENT (first version)

- Make sure that the indicator 3 is in the green zone.

SOFTNESS ADJUSTMENT (second version)

- Set the operator's weight using knob 2.

BACKREST ANGLE ADJUSTMENT (first version)

- Hold the backrest, push the lever 4 backwards and tilt the backrest to the desired position.

BACKREST ANGLE ADJUSTMENT (second version)

- Support the backrest, pull the lever 4 and tilt the backrest to the desired position.

⚠ IMPORTANT ⚠

If you do not support the backrest when making adjustments, it swings completely forwards.

MAINTENANCE

- Keep your seat clean to ensure it operates efficiently
- Clean the cushions using a suitable product.
- Apply to a small hidden area first, to check the colour-fastness of covering.
- Avoid wetting the cushions.



PNEUMATIC DRIVER'S SEAT (Option)

DESIGNED FOR MAXIMUM COMFORT, THIS SEAT CAN BE ADJUSTED AS FOLLOWS.

SEAT WEIGHT AND HEIGHT ADJUSTMENT

Adjust the weight when the driver is sitting on the seat.

- Switch on the lift truck.
- Move the weight adjustment lever 1 upwards to increase the weight or downwards to reduce it.
- The min. and max. weight can be set by engaging the upper or lower limit switch.
- The driver's weight is correctly adjusted when the arrow is in the centre of indicator lamp 2.
- The seat height can be adjusted within this zone.

NB: To avoid any health problems, it is recommended that the weight adjustment is checked and adjusted before starting the lift truck.

⚠ IMPORTANT ⚠

To avoid causing any damage, do not activate the compressor for over 1 minute.



LONGITUDINAL ADJUSTMENT

- Unlock the locking lever 3.
- Slide the seat to the desired position.
- Release the lever and be sure it returns to the lock position.

LUMBAR ADJUSTMENT

This increases the comfort of the seat and the driver's freedom of movement.

- Turn the handle 4 upwards to adjust the height and depth of the lumbar support of the upper part of the backrest.
- Turn the handle 4 downwards to adjust the height and depth of the lumbar support of the lower part of the backrest.

BACKREST ANGLE ADJUSTMENT

- Support the backrest, pull the lever 5 and tilt the backrest to the desired position.

⚠ IMPORTANT ⚠

If you do not support the backrest when making adjustments, it swings completely forwards.

MAINTENANCE

Dirt may adversely affect the correct functioning of the seat. For this reason, make sure your seat is always clean.

- The cushions do not require to be removed from the seat frame for cleaning.

⚠ IMPORTANT ⚠

A moving backrest increases the risk of an accident!

First check the resistance of the fabric on a small concealed area before using any fabric and plastic cleaner.

3 - SEAT BELT

⚠ IMPORTANT ⚠

*Under no circumstances must the lift truck be used if the seat belt is defective (fixing, locking, cuts, tears, etc.).
Immediately repair or replace the seat belt.*

- Sit correctly on the seat.
- Check that seat belt is not twisted.
- Place the seat belt at hip level.
- Attach the seat belt and check that it locks.
- Adjust the seat belt to your body shape without compressing your pelvis and without excessive slack.

4 - IGNITION SWITCH

This switch has 5 positions:

- P - Not used.
- O - Ignition cut-off and engine stop.
- I - Ignition + preheat.
- II - Not used.
- III - Start-up and returns to position I as soon as the key is released.

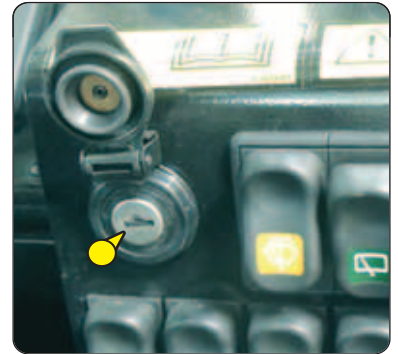

5 - EMERGENCY STOP (Option)

⚠ IMPORTANT ⚠

Be ready for hydraulic movements suddenly stopping when you press this button.

If possible stop the lift truck before using the emergency stop button.

- OFF (locked): Press the button to stop the engine.
- ON (unlocked): Pull the button or turn it a quarter turn clockwise and release it.





6 - BATTERY CUT-OFF

For quickly disconnecting the battery when working on the electric circuit or when soldering, for example.

⚠ IMPORTANT ⚠

Operate the battery cut-off no less than 30 seconds after turning off the ignition with the ignition key.

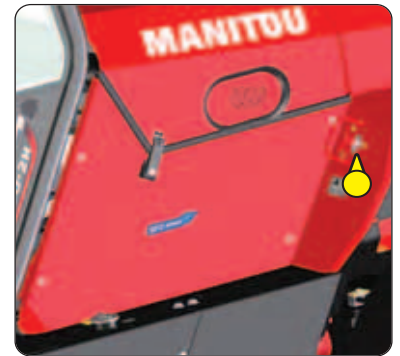

7 - IDENTIFICATION KEYPAD "EasyMANAGER" (Option)

Requires the creation of an identifier for the operator via the portal "EasyMANAGER", for more information contact your dealer.

OPERATION

BY IDENTIFICATION CODE

- Switch on the lift truck, LED 1 lights up.
- Type your identification code and confirm by pressing the key "V".
- The LED 2 lights in green to confirm operator identification.
- Start the lift truck immediately. If you do not start the lift truck immediately, the identification is cancelled and the LED 2 becomes red.

NB: If there is an entry error, the LED 2 lights up red, press the key "X", and wait 10 seconds before entering the correct identification code.

BY IDENTIFICATION CARD

- Switch on the lift truck, LED 1 lights up.
- Present your identification card, a beep will confirm the card has been read.
- The LED 2 lights in green to confirm operator identification.
- Start the lift truck immediately. If you do not start the lift truck immediately, the identification is cancelled and the LED 2 becomes red.



8 - DASHBOARD HANDSET

SIGNAL LIGHTS

⚠ IMPORTANT ⚠

A permanently lit or flashing warning lamp, with the engine running, is the sign of an operating fault.

The lighting of some lamps may be accompanied by an audible signal. Do not ignore this warning, consult your dealer without delay.

If one of the warning lamps comes on while the lift truck is in motion, stop the lift truck under the safest possible conditions.

After the lift truck has been powered on, all the red and orange indicator lamps and the buzzer on the dashboard should come on to indicate that they are working correctly. If any of the red indicator lamps or the buzzer is not working, carry out the necessary repairs.

BATTERY CHARGE FAULT INDICATOR LAMP

If the indicator lamp and buzzer come on when the lift truck is running, stop the engine immediately and determine the cause (electric circuit, alternator belt, alternator, etc.).

PARKING BRAKE INDICATOR LAMP

This indicator lamp comes on when the parking brake is applied.

ENGINE FAULT INDICATOR LAMP

If this lamp comes on while the lift truck is in operation, a diagnostic fault has been detected. The lift truck operates in degraded mode. Contact your dealer as soon as possible.

SEAT BELT INDICATOR LAMP

The light accompanied by a buzzer indicates that the operator has not fastened the seat belt.

ENGINE STOPPED WARNING INDICATOR LAMP

If the indicator lamp lights up or flashes when the lift truck is running, stop the engine immediately and consult your dealer.

HYDRAULIC RETURN FILTER CLOGGING FAULT INDICATOR LAMP

The indicator lamp and the buzzer come on when the hydraulic return oil filter cartridge is clogged. Turn off the engine and carry out the necessary repairs (↖ 3 - MAINTENANCE: FILTER ELEMENTS AND BELTS).

NB: This lamp may come on when starting the lift truck, and it should go off when the hydraulic oil reaches its operating temperature.

AIR FILTER CLOGGING FAULT INDICATOR LAMP

The indicator lamp and the buzzer come on when the air filter cartridge is clogged. Turn off the engine and carry out the necessary repairs (↖ 3 - MAINTENANCE: FILTER ELEMENTS AND BELTS).

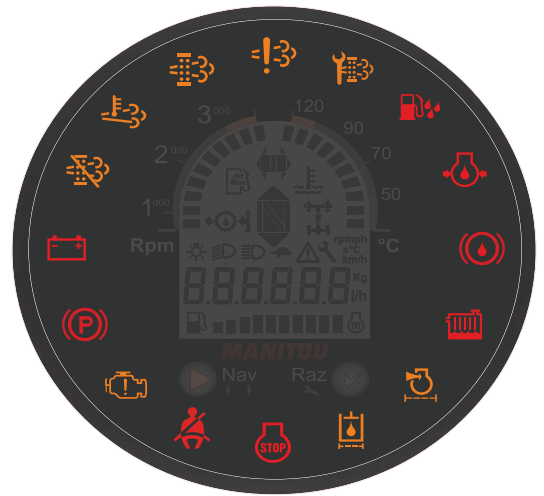



ENGINE WATER LEVEL FAULT INDICATOR LAMP

If the indicator lamp and buzzer come on when the lift truck is running, stop the engine immediately and determine the cause (coolant level, possible leak, radiator, etc.).



BRAKE FLUID LEVEL FAULT INDICATOR LAMP

If the lamp and the buzzer come on when the lift truck is running, stop the engine immediately and look for the cause (brake oil level, possible leak, etc.). If the brake fluid level is abnormal, contact your dealer.



ENGINE OIL PRESSURE FAULT INDICATOR LAMP

If the indicator lamp comes on when the forklift truck is operating, stop the engine immediately and look for the cause (oil level in engine crankcase).

NB: After starting the engine, the indicator lamp remains lit for a few seconds then goes out when the correct engine oil pressure is reached. The full engine power is then available.



WATER IN FUEL PRE-FILTER WARNING INDICATOR LAMP

This light will come on when there is water in the fuel pre-filter. Stop the lift truck and carry out the necessary repairs.



EXHAUST PARTICLE FILTER MAINTENANCE INDICATOR LAMP



EXHAUST PARTICLE FILTER FAULT INDICATOR LAMP



SOOT FOULING LEVEL INDICATOR LAMP



HIGH EXHAUST GAS TEMPERATURE INDICATOR LAMP

The lit indicator lamp indicates a "STATIONARY LIFT TRUCK" EXHAUST REGENERATION in progress (3 - MAINTENANCE: OCCASIONAL MAINTENANCE).



NOT USED

MULTIFUNCTION SCREEN



FORWARD/NEUTRAL/REVERSE PICTOGRAM

◀ FORWARD/NEUTRAL/REVERSE GEAR SELECTION

NB: When the lift truck is switched on, the pictograms flash alternately when the operator engages forward or reverse gear and if:

- The parking brake is applied.
- The operator is not sitting correctly in his seat.



INDICATOR LIGHTS PICTOGRAM

- ◀ LIGHTING, INDICATOR AND HORN SWITCH
- ◀ SWITCHES



MAIN BEAM HEADLIGHTS PICTOGRAM

- ◀ SWITCHES



GENERAL FAULT PICTOGRAM

It is accompanied by an error code on the display. Consult your dealer.



500H MAINTENANCE PICTOGRAM

It is accompanied by the time remaining or the time elapsed on the display (◀ 3 - MAINTENANCE).

NB: The maintenance key appears 50 hours before the deadline and generates an audible signal when the lift truck is started.

To display this time again, use the validation button .



ENGINE PREHEAT PICTOGRAM

Preheating is necessary. After the lift truck has been powered on, the pictogram is displayed, indicating that preheating is in progress. When it disappears, start the engine.

NB: The pictogram flashes when the engine block heater is not connected to the safety socket. ◀ DESCRIPTION (option): ENGINE BLOCK HEATER



NOT USED



NOT USED

A - REV COUNTER

IMPORTANT

Do not exceed the maximum engine speed (◀ SPECIFICATIONS [7.3.1]).

B - ENGINE WATER TEMPERATURE

If the pictogram appears and the buzzer sounds when the lift truck is running, stop the engine immediately and determine the cause (coolant level, possible leak, radiator, etc.).

NB: The intermittent lighting of all the LEDs, appearance of the pictogram and activation of the buzzer indicate a malfunction. Consult your dealer.

C - FUEL LEVEL

If the pictogram appears and the buzzer comes on when the lift truck is running, you are on the reserve tank and your operating time is limited.

NB: The intermittent lighting of all the LEDs, appearance of the pictogram and activation of the buzzer indicate a malfunction. Consult your dealer.

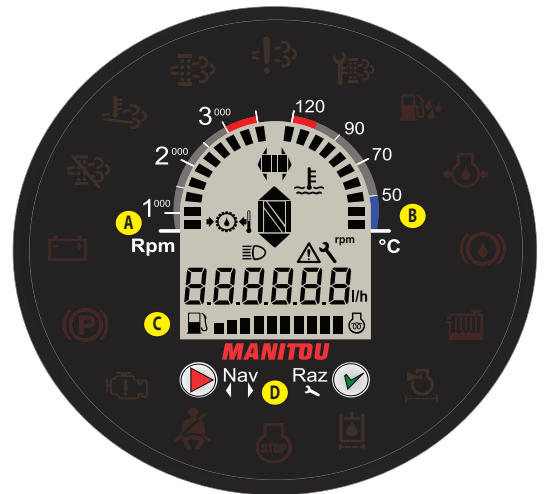

D - NAVIGATION



MENU SCROLL BUTTON

NB: By default, when the lift truck is started, the screen displays the last selection made by the operator.

- 1 - Hour meter (h)
- 2 - Rev counter (rpm)
- 3 - Current fuel consumption (l/h)
- 4 - Forward/reverse -> Rev counter (rpm)
- Neutral -> Hour meter (h)

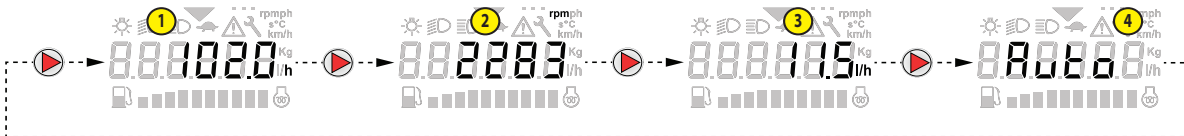

VALIDATION, MAINTENANCE, ERROR CODES AND RESET BUTTON

- 1 - Menu selected by the operator displayed

NO ERROR CODE

- 2 a - Time to 500H maintenance (h)
- To reset this maintenance, carry out the 500-hour maintenance (◀ 3 - MAINTENANCE).
- 3 a - Time to stationary regeneration of the particle filter (h)
- To reset this regeneration, carry out the occasional maintenance (◀ 3 - MAINTENANCE).
- 4 a - No error

WITH ERROR CODE(S)

- 2 b - Error (scroll through error codes in a loop or press ⏴)
- Before contacting your dealer, check the fuses.



In order to resolve the problems with the lift truck, communicate the error code(s) to your dealer.

- 3 b - Time to 500H maintenance (h)
- To reset this maintenance, carry out the 500-hour maintenance (◀ 3 - MAINTENANCE).
- 4 b - Time to stationary regeneration of the particle filter (h)
- To reset this regeneration, carry out the occasional maintenance (◀ 3 - MAINTENANCE).

NB: The countdown from 700 hours to 301 hours displays "dpf ---", and from 300 hours to 0 hours the actual time.

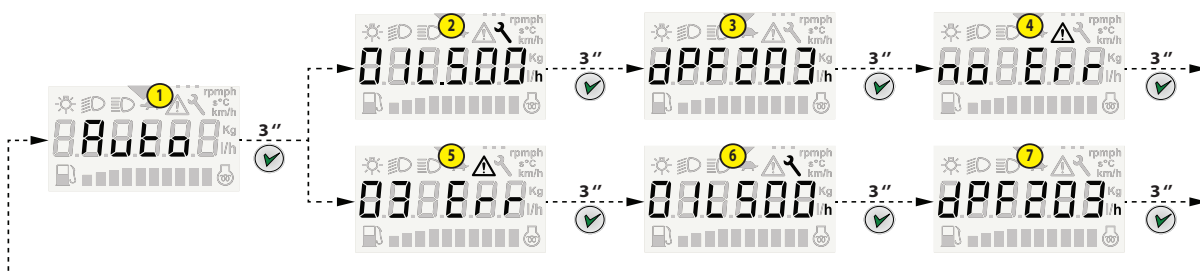



9 - SWITCHES

The location of the switches may vary depending on the options.



HAZARD WARNING LIGHTS

- 0 - Stop
- II - On (indicator lamp on)



HYDRAULIC MOVEMENT NEUTRALISATION

- 0 - Stop
- II - On (indicator lamp on)



HYDRAULIC CIRCUIT DECOMPRESSION MODE

NB: The engine must be stopped and the switch in the off position.

- Sit down correctly in the driver's seat,
- Switch on the lift truck,
- Press the on/off switch (x3) in succession.

It is therefore possible to use certain hydraulic controls, for example:

- Lowering the mast carriage
- Changing attachments













GEAR SELECTOR

- 0 - Stop
- II - Low speed  / High speed  (pulse)

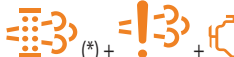

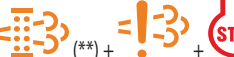
EXHAUST REGENERATION

- 0 - Stop
- II - On (indicator lamp on)

MANAGEMENT OF EXHAUST PARTICLE FILTER REGENERATION	
SIGNALS	ACTIONS
 Normal soot level	- The idling speed is higher, indicating that automatic regeneration is in progress. - the fault indicator  may come on. NB: Preferably wait until automatic regeneration is completed before switching off the ignition.
 (*) + 1 short beep Moderate soot level	- Perform "lift truck stationary" regeneration (< MAINTENANCE). - the fault indicator  may come on.
 (*) + (!) + + 1 long beep High soot level	- Lift truck efficiency is reduced. - Perform "lift truck stationary" regeneration (< MAINTENANCE). - the fault indicator  may come on.
 (**) + (!) + (STOP) (*) + 1 long beep Very high soot level	- Lift truck efficiency is reduced. <div style="text-align: center;">  Stop the lift truck and contact your dealer. </div>
 (**) + (!) + (!) + (STOP) (*) + 1 long beep Particulate filter clogged	- The exhaust particle filter must be replaced. <div style="text-align: center;">  Stop the lift truck and contact your dealer. </div>

(*) Slow flashing

(**) Rapid flashing



FRONT WINDSCREEN WIPER AND WINDSCREEN WASHER

- 0 - Stop
- I - Front windscreen wiper (indicator lamp on)
- II - Windscreen washer (push).

 **REAR WINDSCREEN WIPER + ROOF WINDSCREEN WIPER (Option)**

- 0 - Stop
- I - Rear windscreen wiper (indicator lamp on)
- II - Roof windscreen wiper (pulse)

 **ROTATING BEACON LIGHT OR FLASHING LIGHT (Option)**

- 0 - Stop
- II - On (indicator lamp on)

 **FRONT WORKING LIGHTS (Option)**

- 0 - Stop
- II - On (indicator lamp on)

 **REAR WORKING LIGHTS (Option)**

- 0 - Stop
- II - On (indicator lamp on)

 **HEATING FAN (Option)**

- 0 - Stop
- I - Speed 1 (indicator lamp on)
- II - Speed 2 (indicator lamp on)

10 - LIGHTING, HORN AND INDICATOR SWITCH (Depending on model)

The road lights can be used without the ignition key.

- A - Main beam off
- B - Front and rear side lights
- C - Dipped beam headlights
- D - Main beam headlights
- E - Headlight flasher (push)
- F - Indicators off
- G - Right indicator lights
- H - Left indicator lights
- I - Horn (push)

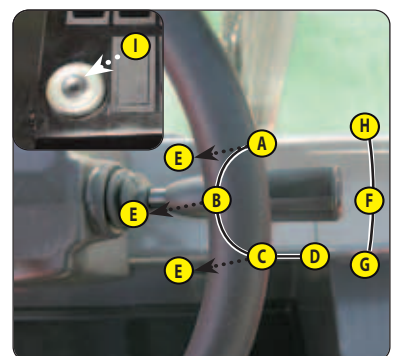
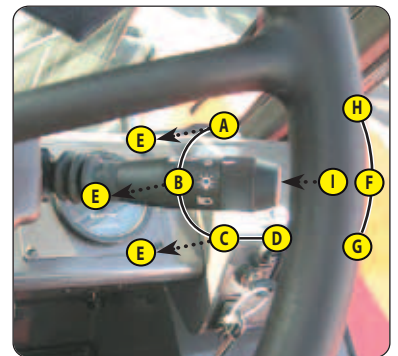

11 - DIAGNOSTIC PLUG

- Remove the protective cover to gain access to the plug (Depending on the model).



12 - ACCELERATOR PEDAL

13 - SERVICE BRAKE PEDAL AND TRANSMISSION CUT-OFF

The pedal acts on the front and rear wheels by a hydraulic system, allowing the lift truck to be slowed down and stopped.

This allows the transmission to be gradually cut off during the free travel range to enable a gradual approach (delicate handling) with full engine power.

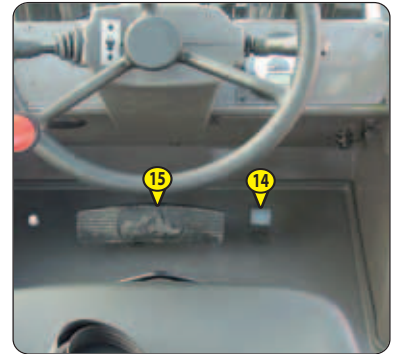

14 - DIFFERENTIAL LOCK PUSHBUTTON

⚠ IMPORTANT ⚠

While the differential lock is engaged, always drive in a straight line in first gear.

The differential lock allows the driving wheels to turn at the same speed regardless of the terrain.



- Press the pushbutton and hold this position for as long as locking is necessary.
- To disengage, simply remove the foot from the pushbutton which will automatically return to its initial position.



15 - GEAR SELECTOR

When starting the lift truck, low speed is automatically selected.

The speed should only be selected when stopped, in neutral gear and with the brake pedal pressed down.

- Press and release the gear selector switch 1 to shift from low speed to high speed.
 -  SLOW SPEED: Use for handling work.
 -  HIGH SPEED: Use on the road.



16 - PARKING BRAKE

To prevent accidental loosening or release, the lever is fitted with safety locking.

- To apply the parking brake, pull the lever backwards (position A).
- To loosen the parking brake, release and push the lever forwards (position B).

NB: If the parking brake is released with the engine off, the audible alarm sounds.

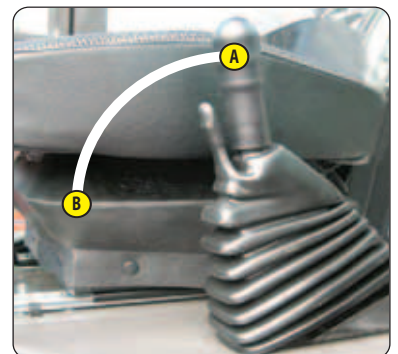

17 - FORWARD/NEUTRAL/REVERSE GEAR SELECTION

FIRST VERSION

When changing the direction of travel, the lift truck should be travelling at slow speed and not accelerating. When the reverser is in the neutral position a mechanical lock prevents accidental engagement of forward or reverse gear.

- A - FORWARD GEAR: Lift slightly and push the lever forwards.
- B - REVERSE GEAR: Lift slightly and pull the lever backwards.
- C - NEUTRAL: To start the lift truck, the lever must be in neutral.

NB: As an option, reversing lights and a reversing sound alarm indicate that the lift truck is running in reverse.

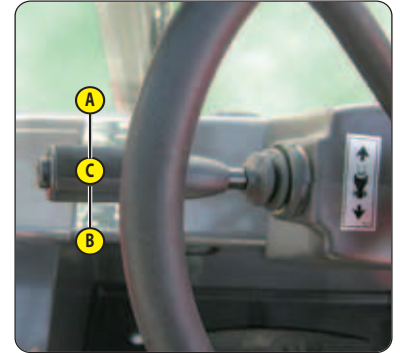

SAFETY FOR MOVING THE LIFT TRUCK

The operator must observe the following sequence to move the truck forwards or backwards:

- sit down correctly in the driver's seat,
- release the hand brake,
- engage forward or reverse gear.

To stop the forklift truck, the following sequence must be observed:

- Set the forward/reverse selector to neutral,
- Apply the parking brake,
- Get out of the lift truck.

If the operator leaves the driver's cab with forward or reverse gear engaged, a sound alarm will be heard.

- Continuously, the operator may sit down again and continue moving forwards or backwards.
- Discontinuously, the operator must sit down again, put the gear selector in neutral and select forward or reverse.

SECOND VERSION

When changing the direction of travel, the lift truck should be travelling at slow speed and not accelerating.

To start the lift truck, the forward/reverse selector must be in neutral.

A - FORWARD GEAR

- Press the front of the switch.

B - REVERSE GEAR

- Press the back of the switch.

NB: A reversing alarm and a reversing light are available as an option.

C - NEUTRAL

- Lightly press the front or back of the switch.

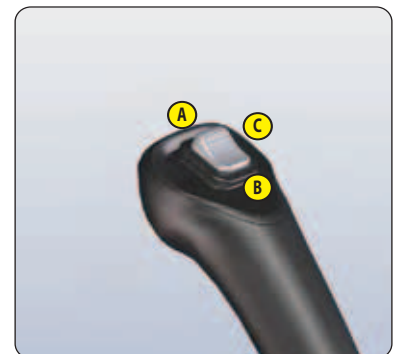

SAFETY FOR MOVING THE LIFT TRUCK

Movement of the lift truck is only authorised if the operator is present and seated in the seat with the seatbelt fastened.

To move the lift truck, the operator must observe the following sequence:

- 1 - Sit down correctly in the driver's seat,
- 2 - Buckle the seat belt,
- 3 - Release the hand brake,
- 4 - Engage forward or reverse gear.

To stop the lift truck, the operator must observe the following sequence:

- 1 - Put the gear selector in neutral,
- 2 - Apply the parking brake,
- 3 - Undo the seat belt,
- 4 - Get out of the lift truck.

If the operator leaves the driver's cab with forward or reverse gear in operation:

- If the alarm emits 1 beep, the operator may sit back in the seat and continue moving.
- If the alarm beeps twice, the operator must sit back in the seat and reset the forward/reverse selector to neutral before continuing to move.

NOTE 1: Depending on the model, a safety device on the seat belt fastener prevents movement. A beep signals it is in operation.



18 - HYDRAULIC CONTROLS

⚠ IMPORTANT ⚠

In the event of a malfunction, contact your dealer.

Do not try to modify the hydraulic pressure of the system.

ANY MODIFICATIONS INVALIDATE THE WARRANTY AND YOU MAY BE HELD LIABLE IN THE EVENT OF AN ACCIDENT.

Use the hydraulic controls gently without jerking, to avoid incidents caused by shaking the lift truck.

NB: Hydraulic control protection is available as an option.

A - LOAD LIFTING CONTROL LEVER

- Lever backwards to lift
- Lever forwards to lower

B - MAST TILTING CONTROL LEVER

- Lever backwards to tilt backwards
- Lever forwards to tilt forwards

NB: As an option, an adaptation of the counter-balance valve on the tilting circuit is available.

C - OPTION CONTROL LEVER

MAST TRAVEL OPTION

⚠ IMPORTANT ⚠

Do not use the travel when the mast is tilted forwards or backwards, as this could damage the mast.

- Lever backwards for travel to the left
- Lever forwards for travel to the right

OPTIONAL ATTACHMENT

- Lever forwards or backwards

D - OPTION CONTROL LEVER

ADDITIONAL ATTACHMENT OPTION

- Lever forwards or backwards



19 - LOAD CHARTS

For your safety, and before handling any load, consult the load charts in the driver's cab.

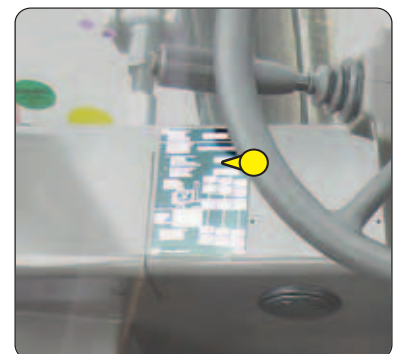

20 - LEVEL INDICATOR

Enables the operator to check that the lift truck is in the horizontal position.



21 - HEATER CONTROL (Option)

A - FAN CONTROL

This 2-speed control allows the air to be ventilated through the air vents.

B - TEMPERATURE CONTROL

Adjusts the temperature inside the cab.

- B1 - The fan pumps in the air at ambient temperature.
- B2 - The fan pumps in warm air.

The intermediate positions allow the temperature to be adjusted.



22 - WINDSCREEN DEMISTER AND HEATING VENTS (Option)

These swivelling heating vents, which can be shut off, allow you to direct and adjust the flow inside the cab.

23 - AIR CONDITIONING CONTROL (Option)

24 - AIR CONDITIONING VENTS (Option)

⚠ IMPORTANT ⚠

*In winter, once a week, operate the air conditioning from time to time to guarantee it is operating correctly.
In cold weather, start and warm up the engine before starting the air conditioning to avoid damaging the air conditioning circuit.*

*If the air conditioning seems to operate irregularly carry out a service (⚠ MAINTENANCE) or consult your dealer.
Never try to repair possible faults in the circuit, consult your dealer.*

- A - On/Off for the air conditioning with indicator lamp
- B - Temperature setting
- C - Ventilation speed adjustment

CONDITIONS OF USE:

- The air conditioning only works:
 - If the engine is running.
 - If the ventilation is working
- The doors and windows must be closed.
- The air intakes must not be obstructed (frost, snow, leaves, etc.).
- As a minimum, one cab heating vent 1 must be open to avoid the risk of the air conditioning circuit freezing.
- To demist, the air conditioning must be on.

NB: Possible water loss under the lift truck are due to the dehumidifying effect of the unit. These losses may vary depending on the exterior temperature and humidity.

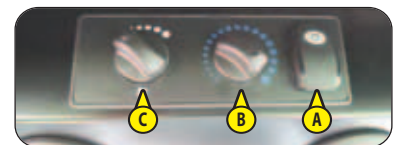
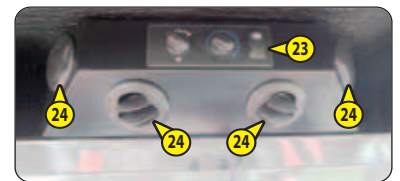

25 - STEERING WHEEL ADJUSTMENT LEVER (Option)

This handle enables the angle and height of the steering wheel to be adjusted.

- Turn the handle 1 towards A to loosen and adjust the steering wheel.
- Turn the handle 1 towards B to lock the steering wheel in the required position.

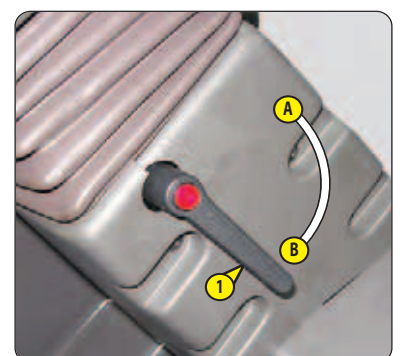

26 - DOOR OPENING HANDLES (Option)

Two keys are provided with the lift truck to enable the cab to be locked.



27 - DOOR UNLOCKING SWITCHES (Option)

- Open the door fully and make sure it is locked in the open position.

28 - STORAGE NET

Ensure that the operator's manual is in its place in the storage net.

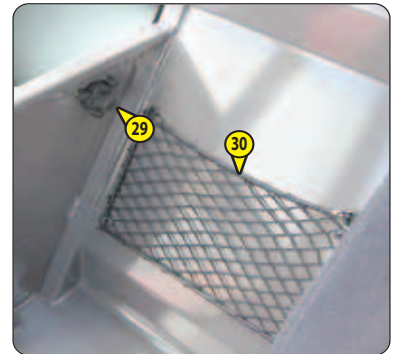

29 - WATERPROOF DOCUMENT-HOLDER (Option)



30 - ROOF LIGHT



31 - SUN VISOR (Option)

32 - INTERNAL REAR-VIEW MIRROR (Option)

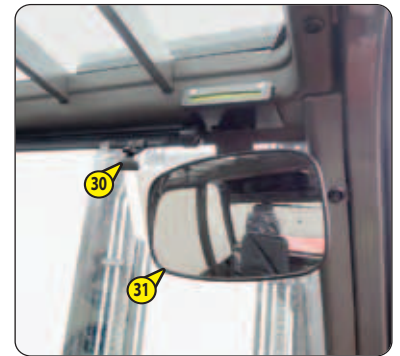

33 - EXTERIOR REAR-VIEW MIRRORS

- A - Left-hand exterior rear-view mirror.
- B - Right-hand external rear-view mirror (Option).



34 - FRONT HEADLIGHTS

- A - Front right headlight and indicator light.
- B - Front right sidelight and dipped headlight.
- C - Front left sidelight and dipped headlight.
- D - Front left headlight and indicator light.



35 - REAR LIGHTS

- A - Left rear light (rear light, brake light and indicator light).
- B - Right rear light (rear light, brake light and indicator light).



36 - FRONT WORKLIGHTS (Option)



37 - REAR WORKLIGHTS (Option)

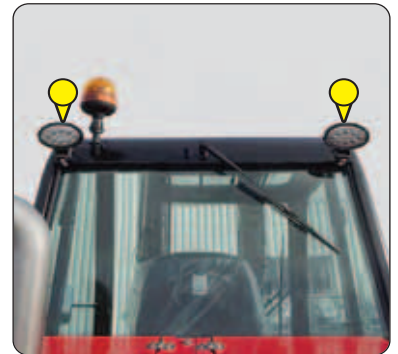

38 - ROTATING BEACON LIGHT (Option)

The rotating beacon light can be removed, for example to reduce the bulkiness of the lift truck or to avoid it being stolen.

- Loosen the nut 1 and remove the rotating beacon light.
- Protect mounting 2 with the cap 3.

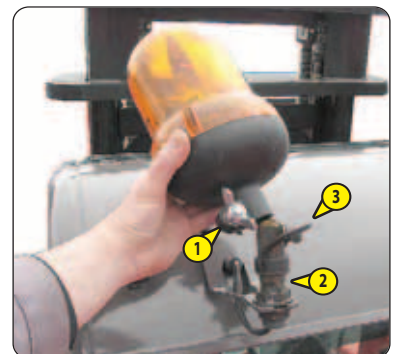

39 - FLASHING LIGHT (Option)

The flashing light can be removed, for example to reduce the bulkiness of the lift truck or to avoid theft.

- Loosen nut 1 and remove the flashing light.
- Protect mounting 2 with the cap 3.

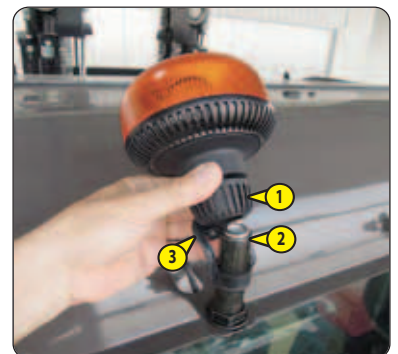

40 - ENGINE BLOCK HEATER (Option)

Enables the engine block to be kept warm during prolonged periods of stoppage and thus improves engine starting.

PREHEATING SYSTEM POWER SUPPLY CHARACTERISTICS:

- Rated power supply voltage range:
 - 220-240V; 50-60Hz; Current consumed: 4.5 A
 - 110-120V; Current consumed: 10 A
- Class 1 equipment
- Equipment connectable only to TT or TN supply systems
- Installation category 2

ENVIRONMENTAL CONDITIONS FOR USE:

- Maximum ambient temperature for using preheat: + 25 °C
- Pollution level 2

CONDITIONS FOR CONNECTION AND USE OF PREHEATING:

- The preheat system should not be used for an external ambient temperature higher than +25 °C.
- It is essential that the power supply to the preheating system:
 - Is effected with a cable that conforms to the installation standards in force and contains a protective earth conductor.
 - Contains an appropriate sectioning system.
 - Incorporates an appropriate safety system against short circuits (fuses or circuit breaker) and a differential circuit breaker with 30 mA sensitivity.
- Only connect to and disconnect from the power supply while the unit is switched off and the engine is stopped.

SAFETY FOR MOVING THE MACHINE:

⚠ IMPORTANT ⚠

To use the machine, plug A on the engine block heater must be connected to safety socket B.

If the engine block heater plug is not connected to the safety socket:

- the machine's movement controls are deactivated
- When the forward/reverse selector is in forward or reverse:
 - The engine preheating symbol flashes on the multifunction display.
 - The pictogram for the required direction is displayed alternately with neutral on the multifunction display.
 - The alarm sounds intermittently.

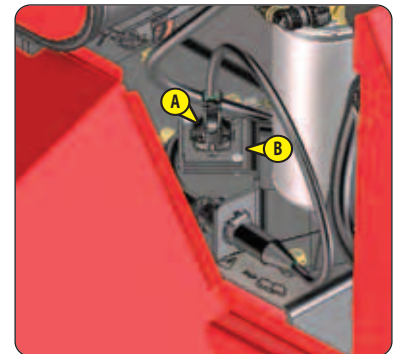

41 - FUEL TANK

As far as possible, keep the fuel tank well filled in order to minimise condensation due to the atmospheric conditions.

⚠ IMPORTANT ⚠

Never smoke or approach with a flame during filling operations or when the tank is open.

Never refill while engine is running.

- If necessary, add diesel (↩ 3 - MAINTENANCE: LUBRICANTS AND FUEL).
- Remove the cap 1.
- Fill the fuel tank with clean diesel filtered through the filler port.
- Refit the cap.
- Check visually that there is no leakage in the tank and pipes.

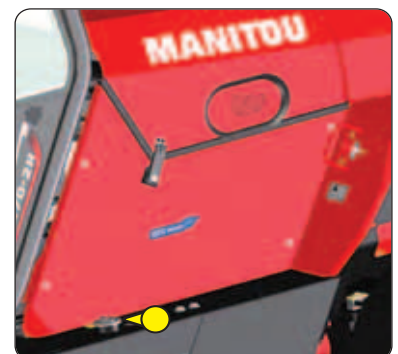

42 - FUSES AND RELAYS

To replace a faulty fuse (↩ 3 - MAINTENANCE: OCCASIONAL MAINTENANCE).



SLINGING PIN

⚠ IMPORTANT ⚠

*This lift truck is not intended for use with a trailer.
IF NECESSARY, CONTACT YOUR DEALER.*

This device is used only for slinging the lift truck (≤ 3 - MAINTENANCE: OCCASIONAL OPERATION).





3 - MAINTENANCE



3 - MAINTENANCE

ORIGINAL MANITOU SPARE PARTS AND EQUIPMENT	3-3
FORKLIFT TRUCK MAINTENANCE	3-4
DAILY AND WEEKLY MAINTENANCE	3-4
MANDATORY FIRST 500 HOURS OR 6 MONTHS SERVICE	3-5
PERIODIC SERVICE	3-6
OCCASIONAL MAINTENANCE AND OPERATION	3-8
FILTER CARTRIDGES AND BELTS	3-9
LUBRICANTS AND FUEL	3-10
➔ 10H - DAILY SERVICE OR EVERY 10 HOURS OF SERVICE	3-12
➔ 50H - WEEKLY SERVICE OR EVERY 50 HOURS OF SERVICE	3-14
➔ ① 500H - PERIODIC SERVICE - EVERY 500 HOURS OF SERVICE OR 1 YEAR	3-20
➔ ② 1000H - PERIODIC SERVICE - EVERY 1,000 HOURS OF SERVICE OR 2 YEARS	3-26
➔ ③ 2000H - PERIODIC SERVICE - EVERY 2,000 HOURS OF SERVICE OR 4 YEARS	3-30
➔ ④ 3000H - PERIODIC SERVICE - EVERY 3,000 HOURS OF SERVICE OR 6 YEARS	3-32
➔ OCCASIONAL SERVICING	3-34
➔ OCCASIONAL OPERATION	3-40



ORIGINAL MANITOU SPARE PARTS AND EQUIPMENT

OUR LIFT TRUCKS MUST BE SERVICED USING ORIGINAL MANITOU PARTS.

BY ALLOWING THE USE OF NON ORIGINAL MANITOU PARTS, YOU RISK:

⚠ IMPORTANT ⚠

THE USE OF COUNTERFEIT PARTS OR COMPONENTS NOT APPROVED BY THE MANUFACTURER, MEANS YOU LOSE THE BENEFIT OF THE CONTRACTUAL GUARANTEE.

- Legally, being held responsible in the event of an accident.
- Technically, causing operating malfunctions or shortening the life of the lift truck.

USING ORIGINAL MANITOU PARTS FOR MAINTENANCE OPERATIONS MEANS THAT YOU BENEFIT FROM OUR KNOW-HOW

Through its network, MANITOU provides the user with,

- Know-how and competence.
- The guarantee of high-quality work.
- Original replacement parts.
- Help with preventive maintenance.
- Efficient help with diagnosis.
- Improvements due to experience feedback.
- Operator training.
- Only the MANITOU network has detailed knowledge of the design of the lift truck and therefore the best technical ability to provide maintenance.

⚠ IMPORTANT ⚠

ORIGINAL REPLACEMENT PARTS ARE DISTRIBUTED EXCLUSIVELY BY MANITOU AND ITS DEALER NETWORK.

The list of dealers is available on the MANITOU website www.manitou.com



FORKLIFT TRUCK MAINTENANCE

DAILY AND WEEKLY MAINTENANCE



THE OPERATOR IS AUTHORISED TO CARRY OUT THIS MAINTENANCE.

These maintenance operations enable the operator to maintain the lift truck in a clean and safe condition.

MANDATORY FIRST 500 HOURS OR 6 MONTHS SERVICE



THIS SERVICE MUST BE CARRIED OUT AFTER THE FIRST 500 HOURS OF SERVICE OR WITHIN THE 6 MONTHS FOLLOWING PUTTING THE MACHINE INTO SERVICE (WHICHEVER OCCURS FIRST).

PERIODIC SERVICE



THE PERIODIC MAINTENANCE MUST BE CARRIED OUT BY AN APPROVED PROFESSIONAL FROM THE MANITOU NETWORK.

MAINTENANCE SCHEDULE

This schedule enables the operator to keep up with the periodic service of the lift truck by notifying the total number of hours of operation and the date of the service performed by the professional approved by the MANITOU network.

OCCASIONAL MAINTENANCE AND OPERATION

These maintenance tasks and operations are to be performed as required for the safety and upkeep of the lift truck.

DAILY AND WEEKLY MAINTENANCE

🔄 10H - DAILY SERVICE OR EVERY 10 HOURS OF SERVICE

- CHECK	Lift truck environment	3-12
- CHECK	Engine oil level.....	3-12
- CHECK	Coolant level.....	3-12
- CHECK	Fuel pre-filter	3-13

🔄 50H - WEEKLY SERVICE OR EVERY 50 HOURS OF SERVICE

- CHECK	Electrical connection protection.....	3-14
- CHECK	Tyre pressures	3-14
- CHECK	Wheel nut tightening	3-14
- CHECK	Front axle differential seal	3-14
- CHECK	Reduction gearbox seal	3-14
- CHECK	Front wheel reducer seals	3-14
- CHECK	Brake fluid level.....	3-15
- CHECK	Tension and alignment of mast lifting chains.....	3-15
- CHECK	Hydraulic oil level	3-16
- CHECK	Windscreen washer liquid level.....	3-16
- CLEAN	Radiator cores	3-16
- CLEAN	Condenser harness (Air conditioning OPTION)	3-17
- LUBRICATE	General lubrication	3-18



MANDATORY FIRST 500 HOURS OR 6 MONTHS SERVICE

FIRST 500 HOURS BEFORE THE FIRST 6 MONTHS

- If the lift truck has reached the first 500 hours of service before the first 6 months have expired, perform both the mandatory service and routine 500 H service (◀ ➡ ⓘ 500H - PERIODIC SERVICE - EVERY 500 HOURS OF SERVICE OR 1 YEAR).

FIRST 6 MONTHS BEFORE THE FIRST 500 HOURS

- If the lift truck has not completed 500 hours of service in the first 6 months, just carry out the mandatory service.

➡ MANDATORY SERVICE

- CHECK	Electrical connection protection	3-14
- CHECK	Tyre pressures	3-14
- CHECK	Wheel nut tightening	3-14
- CHECK	Front axle differential seal	3-14
- CHECK	Reduction gearbox seal	3-14
- CHECK	Front wheel reducer seals	3-14
- CHECK	Brake fluid level	3-15
- CHECK	Tension and alignment of mast lifting chains	3-15
- CHECK	Hydraulic oil level	3-16
- CHECK	Windscreen washer liquid level	3-16
- CLEAN	Radiator cores	3-16
- CLEAN	Condenser harness (Air conditioning OPTION)	3-17
- LUBRICATE	General lubrication	3-18
- CHECK	Countdown before "stationary lift truck" exhaust regeneration	3-20
- CHECK	Parking brake	3-20
- CHECK	Hydraulic oil	3-21
- LUBRICATE	Parking brake lever mechanism	3-21
- GREASE	Mast lifting chains	3-21
- CHECK	Fork wear *	3-24
- CHECK	Seat belt	3-26
- CLEAN	Fuel tank	3-27
- CHECK	Engine silent blocks *	3-29
- CHECK	Brake system pressure *	3-29
- CHECK	Condition of wiring harnesses and cables *	3-29
- CHECK	Lights and signals *	3-29
- CHECK	Warning indicators *	3-29
- CHECK	Condition of the rear-view mirrors *	3-29
- CHECK	Overhead guard structure *	3-29
- CHECK	Cab structure (OPTION) *	3-29
- CHECK	Frame structure *	3-29
- CHECK	Attachment carriage *	3-29
- CHECK	Condition of attachments *	3-29

** Consult your dealer.*



PERIODIC SERVICE

MAINTENANCE SCHEDULE

DUE ➡	OR		500 H or 1 YEAR	1000 H or 2 YEARS	1500 H or 3 YEARS	2000 H or 4 YEARS
	FIRST 6 MONTHS	FIRST 500 HOURS				
PERIODIC SERVICE ➡	MANDATORY SERVICE	MANDATORY SERVICE + ①	①	①+②	①	①+②+③
MACHINE COUNTER ➡						
DATE OF SERVICING ➡						

DUE ➡	2500 H or 5 YEARS	3000 H or 6 YEARS	3500 H or 7 YEARS	4000 H or 8 YEARS	4500 H or 9 YEARS	5000 H or 10 YEARS	5500 H or 11 YEARS
PERIODIC SERVICE ➡	①	①+②	①	①+②+③	①	①+②	①
MACHINE COUNTER ➡							
DATE OF SERVICING ➡							

DUE ➡	6000 H or 12 YEARS	6500 H or 13 YEARS	7000 H or 14 YEARS	7500 H or 15 YEARS	8000 H or 16 YEARS	8500 H or 17 YEARS	9000 H or 18 YEARS
PERIODIC SERVICE ➡	①+②+③	①	①+②	①	①+②+③	①	①+②
MACHINE COUNTER ➡							
DATE OF SERVICING ➡							

➡ ① 500H - PERIODIC SERVICE - EVERY 500 HOURS OF SERVICE OR 1 YEAR

- CHECK	Countdown before "stationary lift truck" exhaust regeneration	3-20
- CHECK	Parking brake	3-20
- CHECK	Hydraulic oil	3-21
- LUBRICATE	Parking brake lever mechanism	3-21
- GREASE	Mast lifting chains	3-21
- REPLACE	Engine oil	3-22
- REPLACE	Engine oil filter	3-22
- REPLACE	Front axle differential oil	3-23
- REPLACE	Hydraulic return oil filter cartridge	3-23
- REPLACE	Hydraulic oil tank filter cap	3-23
- REPLACE	Cab fan filter (OPTION)	3-24
- REPLACE	Air conditioning fan filter (OPTION)	3-24
- CHECK	Fork wear *	3-24

** Consult your dealer.*



➔ ② 1000H - PERIODIC SERVICE - EVERY 1,000 HOURS OF SERVICE OR 2 YEARS

ALSO PERFORM THE 500 HOUR PERIODIC MAINTENANCE OPERATIONS.

- CHECK	Seat belt	3-26
- REPLACE	Dry air filter cartridge	3-26
- CLEAN	Fuel tank	3-27
- REPLACE	Fuel tank breather	3-27
- REPLACE	Fuel pre-filter	3-27
- REPLACE	Fuel filter	3-28
- REPLACE	Coolant	3-28
- REPLACE	Reduction gearbox oil	3-28
- REPLACE	Front wheel reducer oil	3-29
- CHECK	Engine silent blocks *	3-29
- CHECK	Brake system pressure *	3-29
- CHECK	Condition of wiring harnesses and cables *	3-29
- CHECK	Lights and signals *	3-29
- CHECK	Warning indicators *	3-29
- CHECK	Condition of the rear-view mirrors *	3-29
- CHECK	Overhead guard structure *	3-29
- CHECK	Cab structure (OPTION) *	3-29
- CHECK	Frame structure *	3-29
- CHECK	Attachment carriage *	3-29
- CHECK	Condition of attachments *	3-29
- REPLACE	Brake fluid *	3-29
- BLEED	Brake circuit *	3-29
- ADJUST	Brake *	3-29

** Consult your dealer.*

➔ ③ 2000H - PERIODIC SERVICE - EVERY 2,000 HOURS OF SERVICE OR 4 YEARS

ALSO PERFORM THE 500 HOUR AND 1000 HOUR PERIODIC MAINTENANCE OPERATIONS.

- CHECK	Wheel nut tightening torques	3-30
- REPLACE	Hydraulic oil	3-30
- CLEAN	Hydraulic oil tank suction strainer	3-30
- REPLACE	Breather for the hydraulic oil tank	3-30
- CHECK	Radiator *	3-31
- CHECK	Transmission pressures *	3-31
- CHECK	Steering *	3-31
- CHECK	Steering swivel joints *	3-31
- CHECK	Steering swivel joints *	3-31
- CHECK	Condition of mast assembly *	3-31
- CHECK	Mast lifting chains *	3-31
- CHECK	Mast rollers *	3-31
- CHECK	Condition of hoses and flexible pipes *	3-31
- CHECK	Condition of cylinders (leakage, rods) *	3-31
- CHECK	Hydraulic circuit pressures *	3-31
- CHECK	Bearings and bushings of the frame*	3-31
- REPLACE	Alternator belt *	3-31
- CLEAN	Air conditioning (OPTION) *	3-31

** Consult your dealer.*

➔ ④ 3000H - PERIODIC SERVICE - EVERY 3,000 HOURS OF SERVICE OR 6 YEARS

ALSO PERFORM THE 500 HOUR AND 1000 HOUR PERIODIC MAINTENANCE OPERATIONS.

- REPLACE	Dry air filter safety cartridge	3-32
-----------	---------------------------------------	------



OCCASIONAL MAINTENANCE AND OPERATION

↪ OCCASIONAL SERVICING

- CLEAN	"Stationary lift truck" exhaust regeneration	3-34
- CLEAN	Driver's cab	3-34
- CLEAN	Engine compartment	3-35
- CLEAN	Inside of the frame	3-35
- REPLACE	Wheels	3-35
- REPLACE	Fuses and relays in the cab	3-36
- REPLACE	Fuses and relays under engine cover	3-38
- REPLACE	Battery	3-38

↪ OCCASIONAL OPERATION

- TOW OR WINCH	Lift truck	3-40
- SLING	Lift truck	3-41
- TRANSPORT	Lift truck	3-42

FILTER CARTRIDGES AND BELTS

➔ ① 500H - PERIODIC SERVICE - EVERY 500 HOURS OF SERVICE OR 1 YEAR

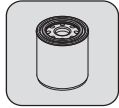

ENGINE OIL FILTER

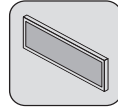

CAB VENTILATION FILTER (OPTION)

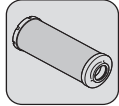

HYDRAULIC RETURN OIL FILTER CARTRIDGE

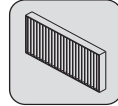

AIR CONDITIONING VENTILATION FILTER (OPTION)

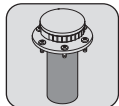

FILTER CAP FOR HYDRAULIC FLUID TANK

➔ ② 1000H - PERIODIC SERVICE - EVERY 1,000 HOURS OF SERVICE OR 2 YEARS

ALSO ADD FILTER CARTRIDGES FOR PERIODIC MAINTENANCE AFTER 500 HOURS OF SERVICE.

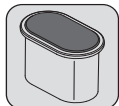

DRY AIR FILTER CARTRIDGE

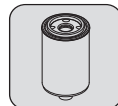

FUEL PRE-FILTER



FUEL TANK BREATHER

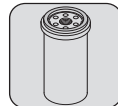

FUEL FILTER

➔ ③ 2000H - PERIODIC SERVICE - EVERY 2,000 HOURS OF SERVICE OR 4 YEARS

ALSO ADD FILTER ELEMENTS FOR PERIODIC MAINTENANCE AT 500 HOURS AND 1,000 HOURS OF SERVICE.

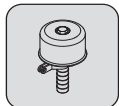

BREATHER FOR THE HYDRAULIC OIL TANK

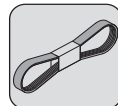

ALTERNATOR BELT

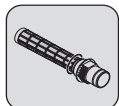

SUCTION STRAINER FOR HYDRAULIC OIL TANK

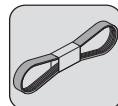

ALTERNATOR BELT
(AIR CONDITIONING OPTION)

➔ ④ 3000H - PERIODIC SERVICE - EVERY 3,000 HOURS OF SERVICE OR 6 YEARS

ALSO ADD FILTER ELEMENTS FOR PERIODIC MAINTENANCE AT 500 HOURS AND 1,000 HOURS OF SERVICE.



SAFETY DRY AIR FILTER CARTRIDGE



BRAKES		
DESCRIPTION	CAPACITY	RECOMMENDATION
BRAKE SYSTEM	1,5 ℓ	MANITOU MINERAL BRAKE FLUID

MAST										
DESCRIPTION	RECOMMENDATION									
	-40 °C	-30	-20	-10	0	+10	+20	+30	+40	+50 °C
MAST LIFTING CHAINS										MANITOU SPECIAL CHAINS LUBRICANT
GREASING OF THE MAST										MANITOU BLACK MULTI-PURPOSE LUBRICANT

HYDRAULIC											
DESCRIPTION	CAPACITY	RECOMMENDATION									
		-40 °C	-30	-20	-10	0	+10	+20	+30	+40	+50 °C
HYDRAULIC OIL TANK	80 ℓ										
											ISO VG 100
											ISO VG 68
											MANITOU ISO VG 46 HYDRAULIC OIL
											ISO VG 37
										ISO VG 68	

OVERHEAD GUARD		
DESCRIPTION	CAPACITY	RECOMMENDATION
WINDSCREEN WASHER TANK	1,5 ℓ	WINDSCREEN WASHER LIQUID

CAB (OPTION)										
DESCRIPTION	CAPACITY	RECOMMENDATION								
		-40 °C	-30	-20	-10	0	+10	+20	+30	+40
CAB DOOR										MANITOU BLUE MULTI-PURPOSE LUBRICANT
WINDSCREEN WASHER TANK	1,5 ℓ									WINDSCREEN WASHER LIQUID

➔ 10H - DAILY SERVICE OR EVERY 10 HOURS OF SERVICE

CHECK

Lift truck environment

⚠ IMPORTANT ⚠

Follow the operator instructions (↖ 1 - OPERATING AND SAFETY INSTRUCTIONS: OPERATOR INSTRUCTIONS).

- Carry out a general inspection of the lift truck:
 - Fluid leaks or stains on the ground.
 - Additional object on the lift truck or in the overhead guard or the cab.
 - Mounting and adjustment of lights and rear view mirrors.
 - Mounting and locking of the attachment.
 - Condition of the tyres, to detect cuts, blisters, wear, etc.
- According to the conditions of use and the environment, ensure that the lift truck is clean:
 - Lights, rear view mirrors, windows, bodywork.
 - Driver's cab (↖ OCCASIONAL MAINTENANCE).
 - Engine housing and inside the frame (↖ OCCASIONAL MAINTENANCE) to prevent leaks and build-up of materials (e.g. straw, flour, sawdust, organic waste, etc.).

⚠ IMPORTANT ⚠

Particular attention should be paid to accumulations of flammable materials and fuel or lubricant leaks. These significantly increase the risk of fire.

CHECK

Engine oil level

Place the lift truck on level ground with the engine stopped, and let the oil settle in the sump.

- Open the left engine cover.
- Pull out dipstick 1.
- Clean the dipstick and check the correct level between the two notches.
- If necessary, add oil (↖ LUBRICANTS AND FUEL) through the filler hole 2.
- Check for leaks.

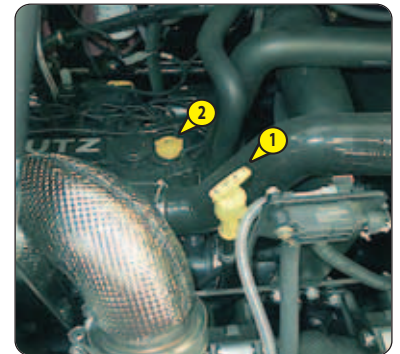

CHECK

Coolant level

Place the lift truck on level ground with the engine stopped, and allow the engine to cool.

⚠ IMPORTANT ⚠

To avoid any risk of spraying or scalding, wait until the engine has cooled down before removing the cooling system filler plug.

In the event of an emergency, it is possible to use water as the coolant, but then proceed to drain the coolant circuit as quickly as possible.

- Open the engine cover.
- Check dipstick 1, the correct level must be at the level of the red dot.
- If necessary, add coolant (↖ LUBRICANTS AND FUEL) through the filler hole 2.
- Visually check that there is no leakage or seepage.

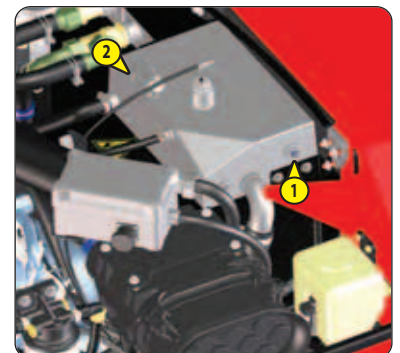

CHECK

Fuel pre-filter

⚠ IMPORTANT ⚠

Carefully clean the outside of the pre-filter and its holder, to prevent dust from getting into the system.

- Open the engine cover.
- Disconnect the electrical wiring harness from the fuel pre-filter.
- Place a hose on the drain plug 1 and the other end in a container.
- Unscrew the drain plug 1 by two turns.
- Allow the diesel fuel to flow out until it is free from impurities and water.
- Retighten the drain plug 1 and reconnect the wiring harness.

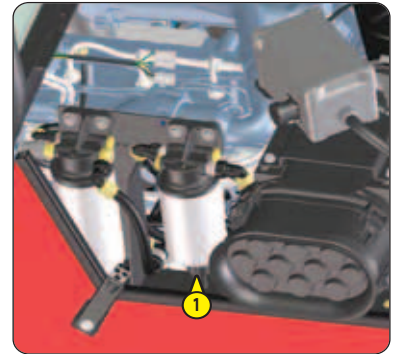

➔ 50H - WEEKLY SERVICE OR EVERY 50 HOURS OF SERVICE

CHECK

Electrical connection protection

⚠ IMPORTANT ⚠

In case of technical faults, consult your dealer.

- Check the presence and condition of all the electrical connection protections.

CHECK

Tyre pressures

CHECK

Wheel nut tightening

⚠ IMPORTANT ⚠

Check that the air hose is correctly connected to the tyre valve before inflating and keep all persons at a distance during inflation. Follow the recommended tyre pressures.

- Check the wheel nut tightening torques. Non-compliance with this instruction can lead to deterioration and breakage of the wheel bolts and distortion of the wheels.
- Check and restore tyre pressures if necessary (↩ 2 - DESCRIPTION: TYRES).

CHECK

Front axle differential seal

Place the lift truck on level ground with the engine stopped.

- Visually check that there is no leakage or seepage.
- If there is any leakage or seepage, check the level:
 - Remove the level plug 1, the oil should be flush with the edge of the hole.
 - If necessary, add oil (↩ LUBRICANTS AND FUEL) by the same hole.
 - Refit and tighten the level plug (tightening torque 34 - 49 N.m).



CHECK

Reduction gearbox seal

Place the lift truck on level ground with the engine stopped.

- Visually check that there is no leakage or seepage.
- If there is any leakage or seepage, check the level:
 - Remove the level plug 1, the oil should be flush with the edge of the hole.
 - If necessary, add oil (↩ LUBRICANTS AND FUEL) by the same hole.
 - Refit and tighten the level plug (tightening torque 34 - 49 N.m).



CHECK

Front wheel reducer seals

Place the lift truck on level ground with the engine stopped.

- Visually check that there is no leakage or seepage.
- If there is any leakage or seepage, check the level:
 - Place level plug 1 in a horizontal position.
 - Remove the level plug; the oil should be flush with the edge of the opening.
 - If necessary, add oil (↩ LUBRICANTS AND FUEL) by the same hole.
 - Refit and tighten the level plug (tightening torque 34 - 49 N.m).



CHECK

Brake fluid level

Place the lift truck on level ground.

⚠ IMPORTANT ⚠

If the brake fluid level is abnormal, contact your dealer.

- Remove the front casing 1.
- Check tank 2. The level is correct when it is situated at the MAX level on the tank.
- Visually check that there is no leakage or seepage.
- If necessary, add oil (↖ LUBRICANTS AND FUEL) through the filler hole 2.
- Refit the front casing 1.



CHECK

Tension and alignment of mast lifting chains

Place the lift truck on level ground with the mast in a vertical position and the forks raised approximately 200 mm.

⚠ IMPORTANT ⚠

These checks are important to ensure correct mast operation.

In case of technical faults, consult your dealer.

- Check the alignment of the mast lifting chains between the carriage chain fasteners and the chain rollers.
- Manually inspect the chain tension and, if necessary, adjust as indicated below while ensuring that the carriage is perpendicular to the mast.
- Loosen the chain tensioner locknut 1.
- Adjust the tension by tightening or loosening the nut 2 while checking the alignment of the lifting chains.
- Then tighten the lock nut 1.
- Retighten the nut 2.

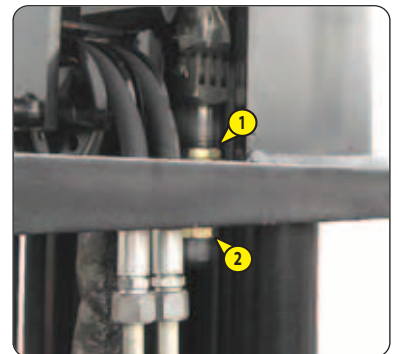

CHECK

Hydraulic oil level

Place the lift truck on level ground with the engine stopped, the mast tilted backwards and lowered as far as possible.

⚠ IMPORTANT ⚠

Use a very clean funnel and clean the top of the oil can before filling.

- Check the dipstick 1, the correct level must be between the two marked lines.
- If necessary, add oil (⚠ LUBRICANTS AND FUEL).
- Remove the lock 2.
- Remove the cap 3.
- Add oil through filler port.
- Refit the cap and the lock.
- Check for leaks.

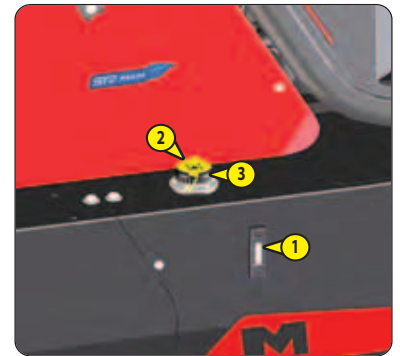

CHECK

Windscreen washer liquid level

Place the lift truck on level ground.

- Open the engine cover.
- Visually check the level in the tank.
- If necessary add windscreen washer fluid (⚠ LUBRICANTS AND FUEL).
- Remove the cap 1.
- Add windscreen washer liquid through filler port.
- Refit the cap.
- Close the engine bonnet.

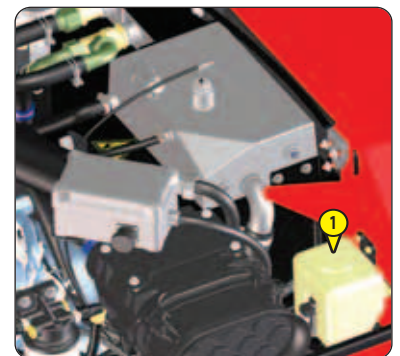

CLEAN

Radiator cores

⚠ IMPORTANT ⚠

In a polluting atmosphere, clean the radiator cores every day.

Do not use a water jet or high pressure steam as this could damage the fins.

- Open the engine cover.
- Remove the suction grille 1 and clean it.
- Using a soft cloth, clean the radiator cores in order to remove as much dirt as possible.
- Clean the radiator with a compressed air jet directed from the radiator towards the engine.

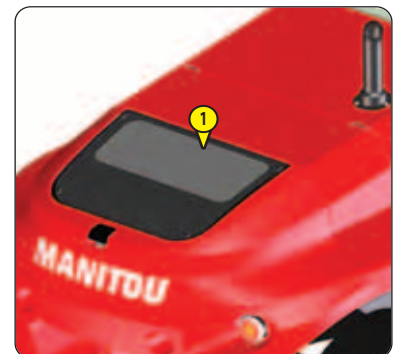



CLEAN

Condenser harness (Air conditioning OPTION)

⚠ IMPORTANT ⚠

In a polluting atmosphere, clean the radiator harness every day. Do not use a water jet or high-pressure steam as this could damage the condenser fins.

- Remove the protective grid 1 and clean it if necessary.
- Visually check whether the condenser is clean and clean it if necessary.
- Clean the condenser using a compressed air jet aimed in the same direction as the air flow.
- Clean with the fans running for best results.

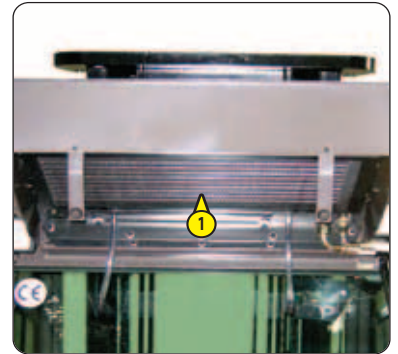



LUBRICATE

General lubrication

To be carried out weekly, if the lift truck has been operated for less than 50 hours during the week.

⚠ IMPORTANT ⚠

In the event of prolonged use in an extremely dusty or oxidising atmosphere, reduce this interval to every 10 hours of service or every day.

- Clean, then lubricate the following points with grease (↙ LUBRICANTS AND FUEL) and remove the surplus.

REAR AXLE

- 1 - Lubricators of the swivel pins (4 lubricators)
- 2 - Rear axle oscillation lubricators (2 lubricators)

MAST

- 3 - Mast foot hinge pins (2 lubricators)
- 4 - Tilt cylinder foot axles (2 lubricators)
- 5 - Tilt cylinder head axles (2 lubricators)
- 6 - Lubricators of upper guide rollers on mast (2 lubricators)
- 7 - Lubricators for mast lower guide rollers (2 lubricators)
- 8 - Lubricators of carriage guide rollers (4 lubricators)

CAB (OPTION)

- 9 - Cab door lubricators (4 lubricators)

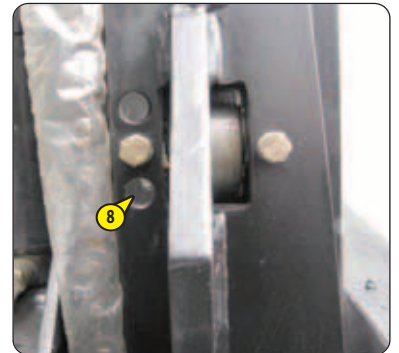
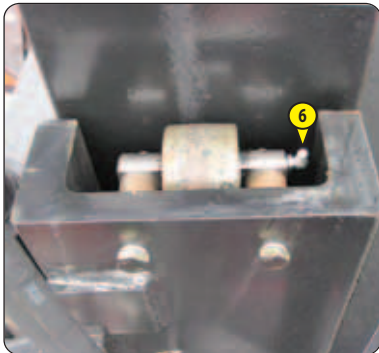
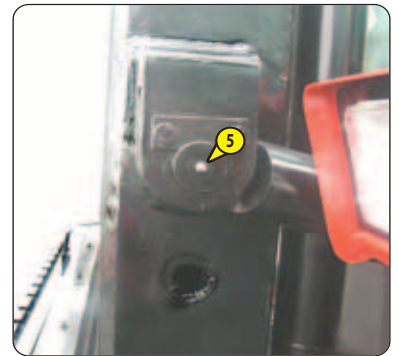
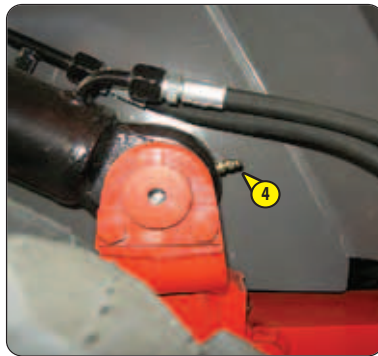
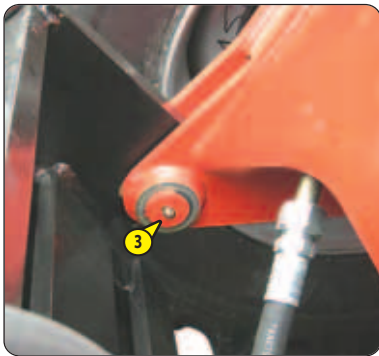
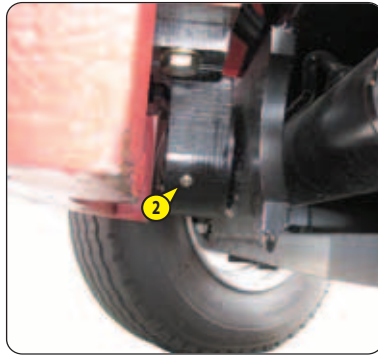
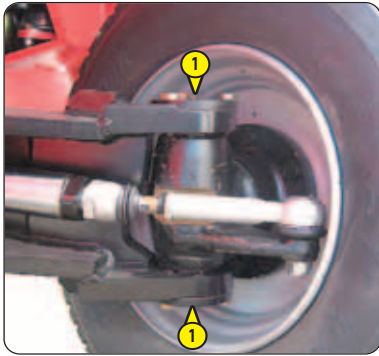

➔ 500H - PERIODIC SERVICE - EVERY 500 HOURS OF SERVICE OR 1 YEAR

CHECK *Countdown before "stationary lift truck" exhaust regeneration*

Depending on the countdown before the next regeneration, you can evaluate and, if necessary, perform a regeneration during the periodic 500-hour service (3 - MAINTENANCE: OCCASIONAL MAINTENANCE).

- Short press button A to move from one screen to the next until the countdown before next regeneration screen is displayed (700h => 0h).



CHECK

Parking brake

⚠ IMPORTANT ⚠

The manufacturer's stop settings must not be changed under any circumstances.

BRAKE SYSTEM CHECK

Place the lift truck on level ground with the engine stopped.

- Remove the cover plate 1.

NB: When removing cover plates and hatches, clean the surrounding area and remove any accumulations of flammable materials.

- If necessary, correctly clean the environment of the connecting rods and setting stops.
- Release then apply the parking brake several times, checking that the connecting rods 2 return to the stops 3.
- In the event of a malfunction, contact your dealer.



BRAKE CHECK

Place the lift truck on a slope of 15% with the rated load in the transport position.

- Immobilise the lift truck using the service brake pedal.
- Firmly apply the parking brake in position A (400 N.m).
- Release the service brake pedal.
- Braking is working correctly if the lift truck remains stationary on the slope.
- In the event of poor braking, contact your dealer.

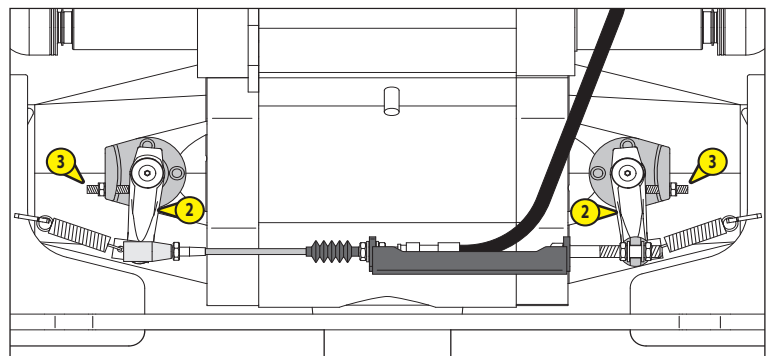

CHECK

Hydraulic oil

MANITOU offers a hydraulic oil analysis kit which makes it possible to extend the recommended interval for routine servicing from 1,000 to 2,000 hours.

In this case, hydraulic oil analyses should be carried out every 500 hours of service.

These analyses make it possible to confirm the oil quality to reach the deadline of 2,000 hours.

NB: This kit is highly recommended for specific uses causing stresses on the hydraulic circuit:

- Extreme environmental conditions
- Use of attachments with a very high hydraulic flow rate (sweepers, mixers, etc.)

ANALYSIS PROCEDURE

- Order an oil analysis kit from your dealer (Part No. MANITOU 958162).
- On receipt of the kit, take a sample and follow the detailed instructions.
- According to the results, keep the analysis report or replace the hydraulic oil.



LUBRICATE

Parking brake lever mechanism

- Clean and lubricate the articulation pins 1 with grease (☞ LUBRICANTS AND FUEL).

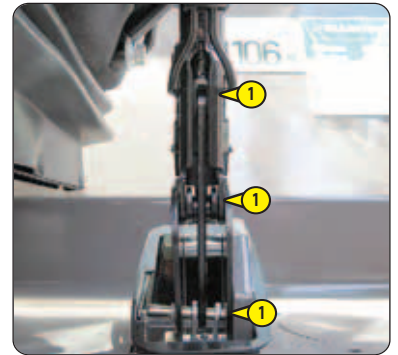

GREASE

Mast lifting chains

- Wipe the mast lifting chains with a clean, lint-free cloth
- Vigorously brush the chains to get rid of any foreign matter, with a hard nylon brush and clean diesel fuel.
- Rinse the chains by means of a paint brush impregnated with clean diesel fuel and dry them with a compressed air jet.
- Carefully check each chain for any signs of wear.

⚠ IMPORTANT ⚠

In case of technical faults, consult your dealer.

- Grease the chains sparingly (☞ LUBRICANTS AND FUEL).

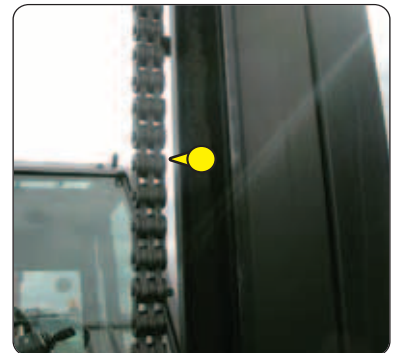

REPLACE

Engine oil

REPLACE

Engine oil filter

Place the lift truck on level ground, let the engine run at idling speed for a few minutes, then stop the engine.

⚠ IMPORTANT ⚠

Dispose of the drain oil in an ecological manner.

Tighten the oil filter by hand pressure only and lock the filter in place by a quarter turn.

DRAINING THE OIL

- Remove the access panel 1.
- NB: When removing the access panel, clean the surrounding area and remove any accumulations of flammable materials.
- Place a container under the drain hole and unscrew the drain plug 2.
- Open the engine cover.
- Take drain hose 3.
- Place the end of the drain hose in the container and screw the hose fully to the drain connector 2.
- Remove the filler plug 4 to ensure correct drainage.

REPLACEMENT OF THE FILTER

- Unscrew and discard the engine oil filter 5, together with its seal.
- Clean the filter bracket with a clean, lint-free cloth.
- Lightly oil the seal before refitting the new oil filter (\leq FILTER CARTRIDGES AND BELTS) on its bracket (tightening torque 15 - 17 N.m).

FILLING WITH OIL

- Remove, clean and refit drain hose 3.
- Refit and tighten the drain plug 2.
- Fill up with oil (\leq LUBRICANTS AND FUEL) through filler hole 4.
- NB: For this operation, we recommend you use a funnel fitted with a hose.
- Wait a few minutes to allow the oil to flow into the sump.
- Start the engine and let it run for a few minutes.
- Check for possible leaks from the drain plug and the oil filter.
- Stop the engine, wait a few minutes and check the correct level between the two marks on the dipstick 6.
- Top up the level if necessary.
- Refit the closing plates 1 (3 closing plates).

INITIALISATION OF 500-HOUR MAINTENANCE

- Contact your agent or dealer.

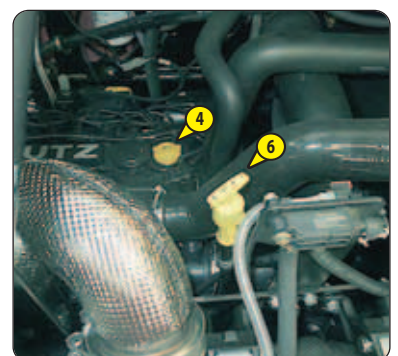
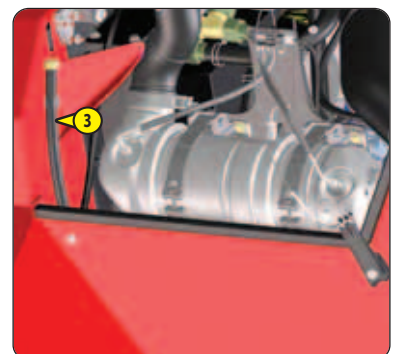
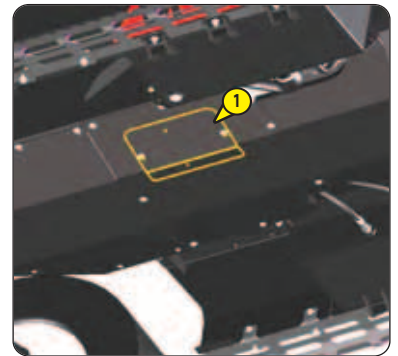

REPLACE

Front axle differential oil

Place the lift truck on level ground with the engine stopped and the still warm differential oil.

⚠ IMPORTANT ⚠

Dispose of the drain oil in an ecological manner.

DRAINING THE OIL

- Place a container under drain plugs 1 and unscrew them.
- Remove level plug 2 and filling plug 3 to ensure that the oil is drained properly.
- Refit and tighten the drain plugs 1 (tightening torque 34 - 49 N.m).
- Fill up with oil (↖ LUBRICANTS AND FUEL) through filler hole 3.
- The level is correct when the oil is flush with the level opening 2.
- Check for any possible leaks at the drain plugs.
- Refit and tighten level plug 2 (tightening torque 34 - 49 N.m) and filler plug 3 (tightening torque 34 - 49 N.m).

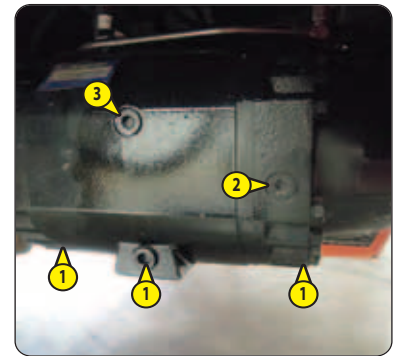

REPLACE

Hydraulic return oil filter cartridge

Stop the engine and release the pressure from the systems by operating the hydraulic controls.

⚠ IMPORTANT ⚠

Thoroughly clean the outside of the filter and its surroundings before any operation to prevent any risk of polluting the hydraulic system.

- Open the engine cover.
- Unscrew the cover 2 by two or three thread turns.
- Wait a few moments while the oil flows into the tank.
- Remove the cover and slowly take out the filter cartridge assembly 3.
- Place the assembly in a clean container and empty the bowl.
- Separate the housing 4 and the head 5 from the filter cartridge 6 with a twisting motion.
- Refit the tank and head onto a new cartridge (↖ FILTER CARTRIDGES AND BELTS).
- Put back the assembly then retighten the cover 2.

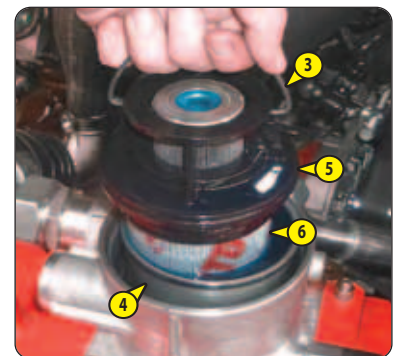
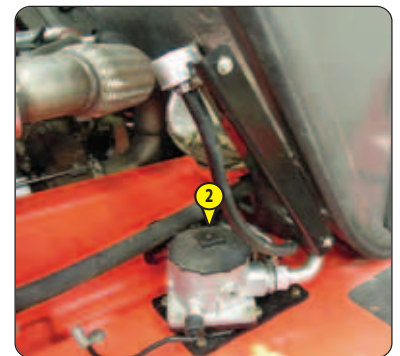

REPLACE

Hydraulic oil tank filter cap

- Remove the filler cap lock 1.
- Unscrew the fixing screws 2, remove and replace the cap filter 2 with a new one (↖ FILTER CARTRIDGES AND BELTS).
- Refit the filler cap lock 1.

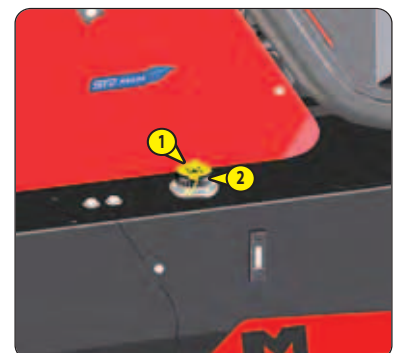

REPLACE

Cab fan filter (OPTION)

- Remove the protective casing 1.
- Take out the ventilation filter 2 and replace it with a new one (⇐ FILTER CARTRIDGES AND BELTS).
- Refit the protective casing.



REPLACE

Air conditioning fan filter (OPTION)

- Remove the protective casing 1.
- Take out the ventilation filter 2 and replace it with a new one (⇐ FILTER CARTRIDGES AND BELTS).
- Refit the protective casing.

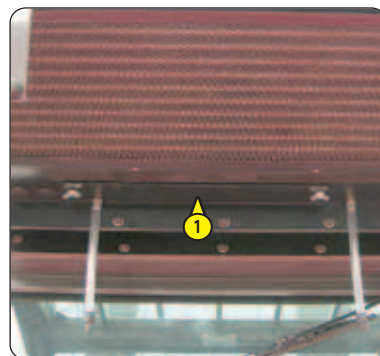

CHECK

Fork wear*

* Consult your dealer.



» 1000H - PERIODIC SERVICE - EVERY 1,000 HOURS OF SERVICE OR 2 YEARS

ALSO PERFORM THE 500 HOUR PERIODIC MAINTENANCE OPERATIONS.

CHECK

Seat belt

⚠ IMPORTANT ⚠

*Under no circumstances must the lift truck be used if the seat belt is defective (fixing, locking, cuts, tears, etc.).
Immediately repair or replace the seat belt.*

SEAT BELT WITH TWO ANCHORING POINTS

- Check the following points:
 - Fixing of the anchoring points on the seat
 - Cleanness of the strap and the locking mechanism
 - Triggering of the locking mechanism
 - Condition of the strap (cuts, curled edges)

REELED SEAT BELT WITH TWO ANCHORING POINTS

- Check the points listed above together with the following points:
 - The correct winding of the belt
 - Condition of the reel guards
 - Roller locking mechanism by giving the strap a sharp tug

NB: After an accident, replace the seat belt.

REPLACE

Dry air filter cartridge

In case of use in a heavily dust-laden atmosphere, the cartridge replacement interval must be reduced (to 250 hours in a heavily dust laden atmosphere).

⚠ IMPORTANT ⚠

*Change the cartridge in a clean location, with the engine stopped.
Never wash a dry air filter cartridge.
Never operate the lift truck with the air filter removed or damaged.*

If the air filter clogging indicator light comes on  replace the cartridge as soon as possible (maximum 1 hour).

- Open the engine cover.
- Loosen the locks and remove cover 1.
- Pivot the cartridge 2 towards the front and carefully remove it to avoid spilling dust as far as possible.
- Leave the safety cartridge in place.
- Carefully clean the following parts with a damp, clean lint-free cloth.
 - The inside of the filter and cover
 - The inside of the filter inlet hose
 - The gasket surfaces in the filter and in the cover
- Check pipes and connections between the air filter and the engine and the connection and state of the clogging indicator on the filter.
- Check the condition of the new filter cartridge before fitting (⇐ FILTER CARTRIDGES AND BELTS).
- Introduce the cartridge into the filter and position it by pressing on the rim, not the middle.
- Refit the cover and ensure that the clips are properly secured. The cover should fit on easily, if this is not the case, check the position of the cartridges in the filter.

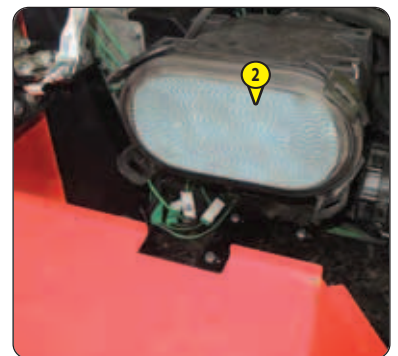
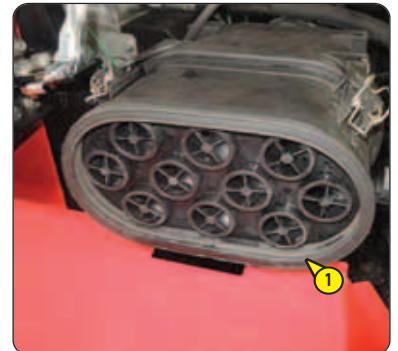

CLEAN

REPLACE

Fuel tank

Fuel tank breather

Place the lift truck on level ground with the engine stopped.

⚠ IMPORTANT ⚠

While carrying out these operations, do not smoke or work near a flame.

Never try to carry out a weld or any other operation by yourself, this could provoke an explosion or a fire.

- Inspect the parts of the fuel circuit and the tank liable to leak, both visually and by touch.
- In the event of a leak, contact your dealer.
- Place a container under drain plug 1 and unscrew the plug.
- Remove the filler plug 2 to ensure correct drainage.
- Rinse with ten litres of clean diesel through filler hole 2.
- Refit and tighten the drain plug 1 (tightening torque 29 - 39 N.m).
- Open the engine cover.
- Unscrew the breather 3 and replace with a new one (⇐ FILTER CARTRIDGES AND BELTS) (tightening torque 3 - 7 N.m).
- Fill the fuel tank with clean diesel filtered through the filler port.
- Refit the filler plug.

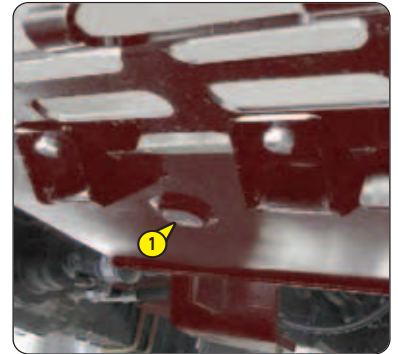

REPLACE

Fuel pre-filter

⚠ IMPORTANT ⚠

Carefully clean the outside of the pre-filter and its holder, to prevent dust from getting into the system.

Tighten the fuel filter by hand only and lock in place by a quarter turn.

- Switch off the lift truck's ignition.
- Open the engine cover.
- Disconnect the electrical wiring harness from the fuel pre-filter.
- Place a hose on the drain plug 1 and the other end in a container.
- Unscrew the drain plug 1 by two turns.
- Open bleed screw 2 to ensure proper emptying.
- Re-tighten bleed screw 2 once the pre-filter is emptied.
- Loosen pre-filter 3 and discard it, together with its seal.
- Clean the inside of the pre-filter head using a brush immersed in clean diesel oil.
- Refit a pre-filter and a new seal lubricated with clean diesel beforehand (⇐ FILTER CARTRIDGES AND BELTS).
- Reconnect the wiring harness on the fuel pre-filter.
- Replace the fuel filter.

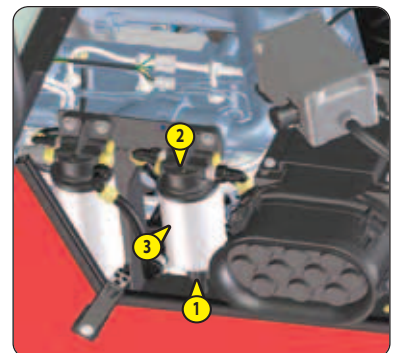

REPLACE

Fuel filter

⚠ IMPORTANT ⚠

Carefully clean the outside of the filter and its holder, to prevent dust from getting into the system.

- Unscrew and discard the fuel filter 1.
- Clean the inside of the filter head using a brush immersed in clean diesel oil.
- Refit a filter and a new seal lubricated with clean diesel beforehand (⇐ FILTER CARTRIDGES AND BELTS).
- Tighten the filter, making sure that the seal is correctly positioned (tightening torque 10 - 12 N.m).
- Open the bleed screw 3 of the fuel pre-filter and the bleed screw 2 of the fuel filter.
- Switch on the lift truck's ignition, and close the bleed screw as soon as the diesel flows with no air.

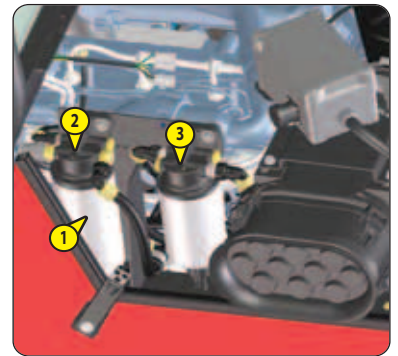

REPLACE

Coolant

These operations are to be carried out as necessary or every 2 years at the beginning of winter. Place the lift truck on level ground, with the engine off and cold.

⚠ IMPORTANT ⚠

The engine does not contain any anti-corrosion elements and must be filled throughout the year with a mixture containing 25% ethylene glycol-based antifreeze.

- Open the engine cover.

DRAINING THE LIQUID

- Place a container under hose 1 of the radiator.
- Remove the hose.
- Remove the filler plug 2 from the expansion tank to ensure correct drainage.
- Let the cooling circuit drain entirely while ensuring that the ports do not get clogged.
- Check the condition of the hoses and their fixings, and change the hoses if necessary.
- Rinse the circuit with clean water, or use a cleaning agent if necessary.

FILLING WITH COOLANT

- Refit and tighten the hose 1.
- Slowly fill the circuit with coolant (⇐ LUBRICANTS AND FUEL) up to the MAX level on the dipstick 3 through the filler hole.
- Refit the filler plug 2.
- Run the engine at idle for a few minutes.
- Check for any possible leaks.
- Check the level and refill if necessary.

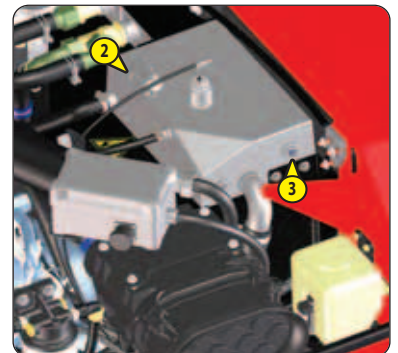
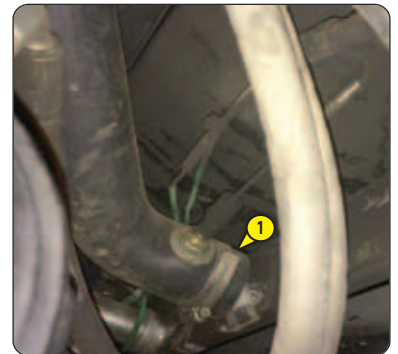

REPLACE

Reduction gearbox oil

Place the lift truck on level ground with the engine stopped and the reduction gearbox oil still warm.

⚠ IMPORTANT ⚠

Dispose of the drain oil in an ecological manner.

DRAINING THE OIL

- Place a container under drain plug 1 and unscrew the plug.
- Remove level and filling plug 2 to ensure correct drainage.
- Refit and tighten the level plug 1 (tightening torque 34 - 49 N.m).
- Fill up with oil (⇐ LUBRICANTS AND FUEL) through filler hole 2.
- The level is correct when the oil level is flush with the edge of the hole.
- Check for any possible leaks at the drain plug.
- Refit and tighten the level and filling plug 2 (tightening torque 34 - 49 N.m).

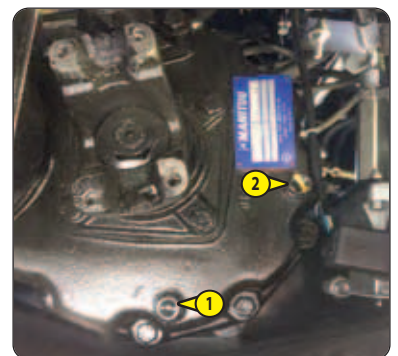

REPLACE

Front wheel reducer oil

Place the lift truck on level ground with the engine stopped and the reducers' oil still warm.

⚠ IMPORTANT ⚠

Dispose of the drain oil in an ecological manner.

- Drain and change the oil of each wheel reduction gear.
- Place drain plug 1 in position A.
- Place a container under the drain plug and unscrew the plug.
- Let the oil drain fully.
- Place the drain port in position B, i.e. in a level port.
- Top up with oil (↔ LUBRICANTS AND FUEL) through level hole 1.
- The level is correct when the oil level is flush with the edge of the hole.
- Refit and tighten the drain plug (tightening torque 34 - 49 N.m).

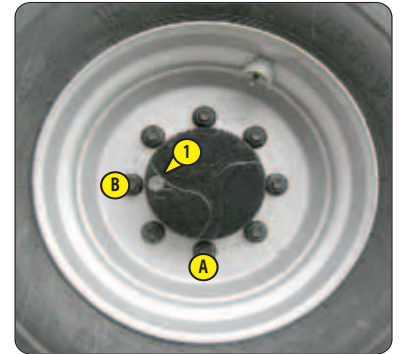

CHECK

Engine silent blocks *

CHECK

Brake system pressure *

CHECK

Condition of wiring harnesses and cables *

CHECK

Lights and signals *

CHECK

Warning indicators *

CHECK

Condition of the rear-view mirrors *

CHECK

Overhead guard structure *

CHECK

Cab structure (OPTION) *

CHECK

Frame structure *

CHECK

Attachment carriage *

CHECK

Condition of attachments *

REPLACE

Brake fluid *

BLEED

Brake circuit *

ADJUST

Brake *

** Consult your dealer.*

🔧 2000H - PERIODIC SERVICE - EVERY 2,000 HOURS OF SERVICE OR 4 YEARS

ALSO PERFORM THE 500 HOUR AND 1000 HOUR PERIODIC MAINTENANCE OPERATIONS.

CHECK

- Check the condition of the tyres to detect cuts, blisters, wear, etc.
- Check the tightening torque of the wheel nuts with a torque wrench:
 - Front wheels = 630 N.m ± 94 N.m
 - Rear wheels = 340 N.m ± 51 N.m

Wheel nut tightening torques

REPLACE

Hydraulic oil

CLEAN

Hydraulic oil tank suction strainer

REPLACE

Breather for the hydraulic oil tank

Place the lift truck on level ground with the engine stopped, the mast tilted backward and lowered as far as possible.

⚠️ IMPORTANT ⚠️

Before any intervention, thoroughly clean the area surrounding the filler plug and the filter, the drain plug and the suction strainer on the hydraulic tank.

Dispose of the drain oil in an ecological manner.

Use a very clean container and funnel and clean the underside of the oil drum before filling.

- Open the engine cover.

DRAINING THE OIL

- Place a container under drain plug 1 and unscrew the plug.
- Remove the filler cap lock 2.
- Remove the filler plug 3 to ensure correct drainage.
- Allow the hydraulic tank to empty completely.

CLEANING THE SUCTION STRAINER

- Remove the suction hose 4.
- Remove and clean the suction strainer 5 using a compressed air jet, check its condition and replace if necessary (⇐ FILTER CARTRIDGES AND BELTS).
- Refit the strainer and the hose.

REPLACING THE BREATHER

- Unscrew the breather 6 and replace it with a new one (⇐ FILTER CARTRIDGES AND BELTS).

FILLING WITH OIL

- Clean and refit the drain plug 1 (tightening torque 73 - 97 N.m).
- Fill up with oil (⇐ LUBRICANTS AND FUEL) through filler hole 3.
- Observe the oil level on the dipstick 7; the oil level should be between the two marked lines.
- Check for any possible leaks at the drain plug.
- Refit the cap and the lock.

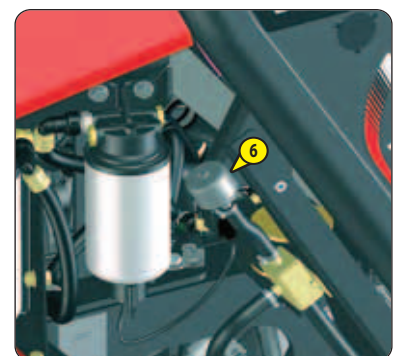
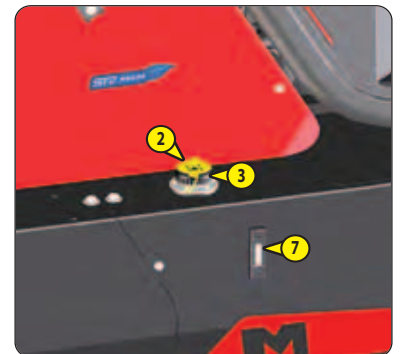



CHECK	Radiator *
CHECK	Transmission pressures *
CHECK	Steering *
CHECK	Steering swivel joints *
CHECK	Steering swivel joints *
CHECK	Condition of mast assembly *
CHECK	Mast lifting chains *
CHECK	Mast rollers *
CHECK	Condition of hoses and flexible pipes *
CHECK	Condition of cylinders (leakage, rods) *
CHECK	Hydraulic circuit pressures *
CHECK	Bearings and bushings of the frame *
REPLACE	Alternator belt *
CLEAN	Air conditioning (OPTION) *

** Consult your dealer.*

➔ ④ 3000H - PERIODIC SERVICE - EVERY 3,000 HOURS OF SERVICE OR 6 YEARS

ALSO PERFORM THE 500 HOUR AND 1000 HOUR PERIODIC MAINTENANCE OPERATIONS.

REPLACE

Dry air filter safety cartridge

⚠ IMPORTANT ⚠

The frequency of changing the safety cartridge is given as an example. It must be changed every second time the dry air filter cartridge is changed.

- For the dismantling and refitting of the cartridge (≪ 2,000 HOURS: REPLACE Air filter cartridge).
- Remove the dry air filter safety cartridge 1 carefully, to minimise dust fall.
- Clean the gasket surface on the filter with a damp, clean lint-free cloth.
- Check the condition of the new safety cartridge before fitting (≪ FILTER CARTRIDGES AND BELTS).
- Insert the cartridge in the filter axis and push the cartridge pressing against the outer edge and not the centre.





➔ OCCASIONAL SERVICING

CLEAN

"Stationary lift truck" exhaust regeneration

⚠ IMPORTANT ⚠

If the indicator lamp  comes on, contact your dealer.



If you carry out a regeneration during the periodic 500-hour service, perform this regeneration before replacing the engine oil.



Exhaust regeneration is an automated procedure to be performed by the operator when the following indicator lamps are displayed:

-  (flashing) + 1 short beep.
-  (flashing) +  +  + 1 long beep.

- Park the lift truck in a safe and adequately ventilated place.
- Check the following points:
 - forward/reverse selector in neutral
 - parking brake applied
 - forks resting on the ground
 - idling speed
- Check that the fuel level is sufficient.
- Start the lift truck and run the engine for a few minutes to bring it up to its normal operating temperature.
- Press down on the bottom of switch 1 for more than two seconds to begin exhaust regeneration. Indicator lamp  coming on fixed and the engine speed increasing confirm the start of regeneration.

- The indicator lamp  comes on and confirms the start of the regeneration procedure.
- The indicator lamp  comes on as soon as the particulate filter temperature is high enough.

⚠ IMPORTANT ⚠



The regeneration procedure must only be stopped if absolutely necessary.

The procedure stops automatically if the operator:

- engages forward or reverse gear,
- releases the parking brake.
- presses on the accelerator pedal,
- switches off the engine,
- presses switch 1.

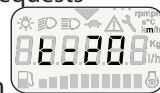
- The duration of the regeneration procedure varies between 30 and 40 minutes according to various criteria, such as:
 - the level of clogging of the filter
 - the ambient temperature
 - the fuel quality and type of engine oil
 - the number of automatic regeneration cancellation requests



- The time remaining appears on the multifunction screen .
- At the end of the regeneration procedure, the indicator lamp  goes out and the time remaining before stationary exhaust particle regeneration is reset.

CLEAN

Driver's cab

NB: The frequency of cleaning is given as an example.

⚠ IMPORTANT ⚠

Do not use a high pressure cleaner or water jet.

Take precautions with electrical and electronic components.

- Clean the inside of the overhead guard or the cab using a small brush, vacuum cleaner and a cloth.

CLEAN

Engine compartment

CLEAN

Inside of the frame

⚠ IMPORTANT ⚠

Do not use a water jet or high-pressure steam.

- Open the engine cover.
- Remove the side panels.
- Clean the engine compartment and the inside of the frame using a compressed air jet.

REPLACE

Wheels

⚠ IMPORTANT ⚠

In the event of a wheel being changed on the public highway, secure the lift truck vicinity:

- Stop the lift truck, if possible on firm, level ground.
- Stop the lift truck (⚠ 1 - OPERATING AND SAFETY INSTRUCTIONS: OPERATING INSTRUCTIONS WITH AND WITHOUT LOAD).
- Switch on the hazard warning lights.
- Immobilise the lift truck in both directions on the axle opposite to the wheel to be changed.
- Undo the nuts of the wheel to be changed until they can be removed easily.

REAR WHEEL

For this operation, we advise you to use the hydraulic jack (MANITOU Part No.: 505507).

- Place and adjust the jack under the rear axle, as near as possible to the wheel.
- Lift the wheel until it comes off the ground and put in place the safety block under the axle.
- Completely unscrew the wheel nuts and remove them.
- Free the wheel using back and forth movements and roll it to the side.
- Slip the new wheel on the wheel hub.
- Hand-tighten the nuts, grease them if necessary.
- Remove the security block and lower the lift truck with the jack.
- Tighten the wheel nuts with a torque wrench (⚠ 2000H - PERIODIC SERVICE - EVERY 2,000 HOURS OF SERVICE OR EVERY 4 YEARS) for the tightening torque.

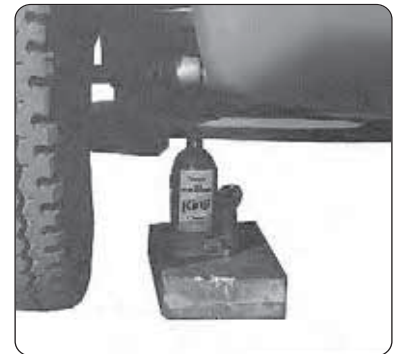

FRONT WHEEL

For this operation, we advise you to use the hydraulic jack (MANITOU Part No.: 505507) and the safety support prop (MANITOU Part No.: 554772).

- Place and adjust the jack under the flared axle tube, as near as possible to the wheel.
- Lift the wheel until it comes off the ground and put in place the safety support under the frame.
- Loosen the wheel nuts and remove them completely.
- Free the wheel using back and forth movements and roll it to the side.
- Place the new wheel on the wheel hub.
- Hand-tighten the nuts, grease them if necessary.
- Remove the security block and lower the lift truck with the jack.
- Tighten the wheel nuts with a torque wrench (⚠ 2000H - PERIODIC SERVICE - EVERY 2,000 HOURS OF SERVICE OR EVERY 4 YEARS) for the tightening torque.

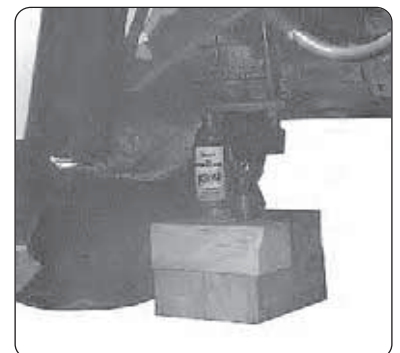



REPLACE

Fuses and relays in the cab

⚠ IMPORTANT ⚠

Replace a faulty fuse with a new one of equivalent rating.
Never use a repaired fuse.

- Remove the access panel 1 to gain access to the fuses and relays.

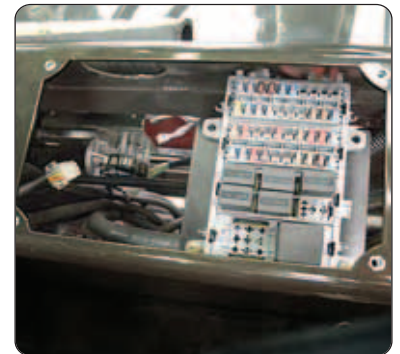
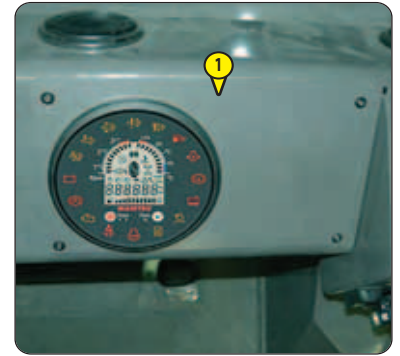

FIRST VERSION

MINIFUSE

F1	15 A	Front worklights (Option)
F2	15 A	Rear worklights (Option)
F3	10 A	Rear axle clutch
F4	7,5 A	Rotating beacon light (Option)
F5	7,5 A	Car radio (Option)
	15 A	Car radio (Option) Pneumatic seat (Option)
F6	3 A	Identification keypad "EasyMANAGER" (Option)
F7	5 A	Diagnostics plug
F8	5 A	Control instruments panel
F9	7,5 A	Rear windscreen wiper
	15 A	Rear windscreen wiper Roof windscreen wiper (Option)
F10	15 A	Front windscreen wiper
		Front windscreen washer
F11	5 A	Engine ECU
F12	10 A	Movement cut-off
F13	15 A	Air conditioning (Option)
F14	15 A	Free
F15	10 A	Horn
		Stop switch
F16	15 A	Free
F17	5 A	Regeneration information
		Transmission cut-off
F18	10 A	Flashing light unit
F19	10 A	Forward/neutral/reverse gear selection
		Forward/neutral/reverse power relay
F20	15 A	Ventilation/heating (Option)
F21	20 A	Lighting, horn and indicator switch
F22	15 A	Front windscreen wiper
F23	3 A	Roof light (Option)
F25	5 A	Free
F26	5 A	Free
F28	5 A	Diagnostics plug
F29	5 A	Transmission cut-off
F30	15 A	Hazard warning lights
F31	3 A	Sidelights
		Sidelights indicator lamp Control panel illumination
F32	3 A	Air conditioning lighting (Option)
F33	7,5 A	Right indicator lights
F34	7,5 A	Left indicator lights
F35	15 A	Dipped beam headlights
F36	15 A	Main beam headlights
F37	3 A	Anti-start

RELAYS

K1	Forward/neutral/reverse power relay
K2	Forward gear control
K3	Reverse gear control
	Reversing sound alarm (Option)
K4	Neutral position control
	Movement cut-off Start safety
K5	Movement cut-off
K7	General power supply
	Air conditioning (Option)
K8	Air conditioning (Option)
K9	Hydrostatic pump
K10	Hydrostatic pump
K11	Flashing light unit
K12	Hydrostatic pump

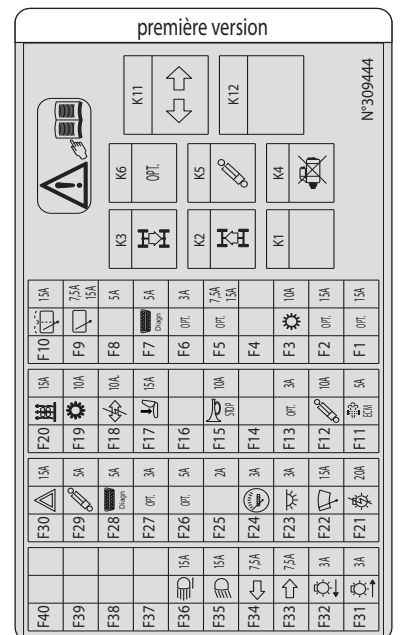



SECOND VERSION

MINIFUSE

F1	15 A	Front worklights (Option)
F2	15 A	Rear worklights (Option)
F3	10 A	Rear axle clutch (Option)
F4	7,5 A	Rotating beacon light (Option)
F5	7,5 A	Car radio (Option)
F6	3 A	Identification keypad "EasyMANAGER" (Option) + 12V primary ignition supply
F7	5 A	Diagnostics plug
F8	5 A	Control instruments panel
F9	15 A	Free
F10	15 A	Front windscreen wiper
F11	5 A	Fuel preheat Diagnostics plug
F12	3 A	Relay power supply K2
F13	15 A	Free
F14	15 A	Free
F15	10 A	Horn Stop switch
F16	15 A	Free
F17	5 A	Transmission cut-off switch Regeneration information
F18	10 A	Hazard warning lights
F19	10 A	Forward/neutral/reverse gear selection
F20	15 A	Ventilation/heating (Option)
F21	20 A	Lighting, horn and indicator switch
F22	15 A	Front windscreen wiper automatic return
F23	3 A	Roof light
F24	5 A	SPU ECU +12V permanent
F25	5 A	Free
F26	5 A	Car radio (Option)
F27	3 A	Hazard warning lights
F28	5 A	Diagnostics plug
F29	5 A	Transmission cut-off on gear lever (Option)
F30	20 A	SPU ECU +12V permanent
F31	3 A	right sidelights Sidelights indicator lamp Control panel illumination
F32	3 A	left sidelights Air conditioning lighting (Option)
F33	7,5 A	Right indicator lights
F34	7,5 A	Left indicator lights
F35	15 A	Dipped beam headlights
F36	15 A	Main beam headlights
F37	3 A	Identification keypad "EasyMANAGER" (Option) +12V permanent
F38	5 A	Engine immobiliser shunt
F39	7,5 A	SPU ECU +12V primary ignition supply
F40	7,5 A	SPU ECU +12V primary ignition supply
F100	30 A	Air conditioning (Option)

RELAYS

K1	SPU ECU +12V permanent
K2	Hydraulic ground
K6	Air conditioning (Option)
K7	+12V primary ignition supply
K11	Flashing light unit

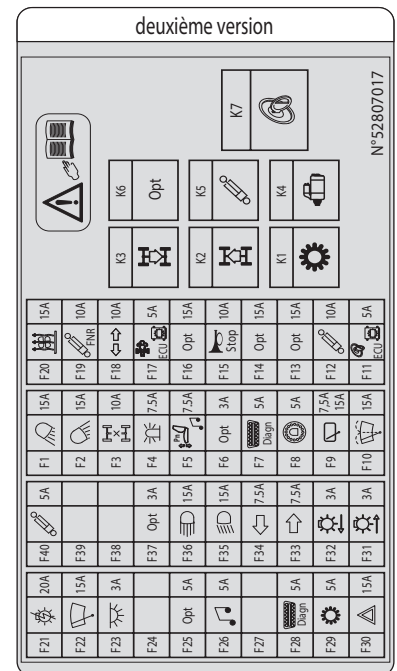

REPLACE

Fuses and relays under engine cover

⚠ IMPORTANT ⚠

Replace a faulty fuse with a new one of equivalent rating.
Never use a repaired fuse.

- Open the engine cover.
- Remove the cover 1 in order to gain access to the fuses and relays.

MINIFUSE

F51	5A	Engine diagnostics plug
F52		Free
F53		Free
F54		Free
F55	15A	Fuel pump
F56	30A	Fuel pre-heating (Option)

MAXIFUSE

F57	30A	Engine ECU
F58	100A	Engine preheat (Option)
F59	80A	Overhead guard power supply / Cab

RELAYS

K21	Engine preheat (Option)
K23	Fuel pump

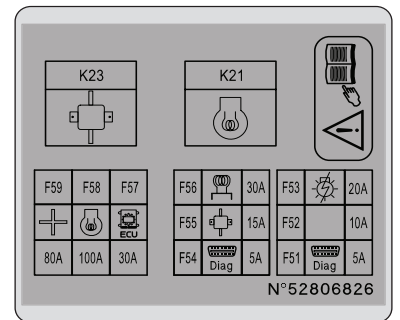
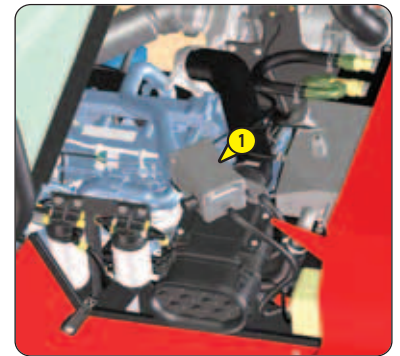

REPLACE

Battery

⚠ IMPORTANT ⚠

Operate the battery cut-off for a minimum of 30 seconds after having switched off the ignition with the ignition key.
Handling and servicing a battery can be dangerous. Take the following precautions:

- Wear protective goggles.
- Keep the battery horizontal.
- Never smoke or work near a naked flame.
- Work in a well-ventilated area.

- In the event of electrolyte being spilled onto the skin or splashed in the eyes, rinse thoroughly with cold water for 15 minutes and call a doctor.

REPLACING THE BATTERY

- Remove the protective grid 1.
- Remove the screws from the battery 2.
- Replace the battery.

CONNECTION OF A BACKUP BATTERY

- Remove the protective grid 1.
- Bring a backup battery of the same type as the one used for the lift truck, together with battery cables.
- Connect the backup battery, respecting the polarity (-) and (+).
- Start the lift truck and remove the cables as soon as the engine is running.

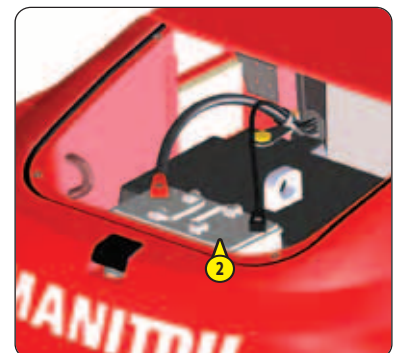
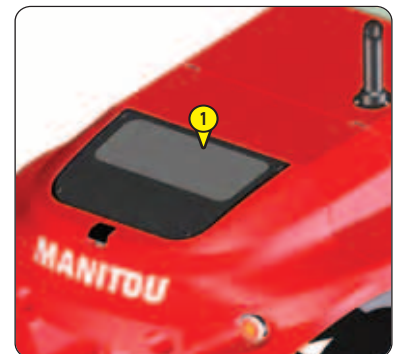



➔ OCCASIONAL OPERATION

TOW OR WINCH

Lift truck

⚠ IMPORTANT ⚠

The lift truck must be towed very slowly (less than 5 km/h) and for as short a distance as possible (less than 100 m).

Before towing, the high pressure limiters 2 must be unlocked to avoid damaging the hydrostatic transmission.

- Remove the inspection panel 1.
- Loosen the locknuts 3.
- Loosen the screws HC 4 by three turns.
- Release the hand brake.
- Switch on the hazard warning lights.
- After towing, proceed in the reverse order to lock the high pressure limiters.

Since there will be no steering or braking hydraulic assistance, operate the steering and pedal slowly. Avoid sudden or jerky movements.

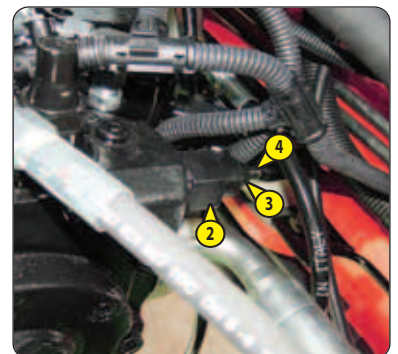
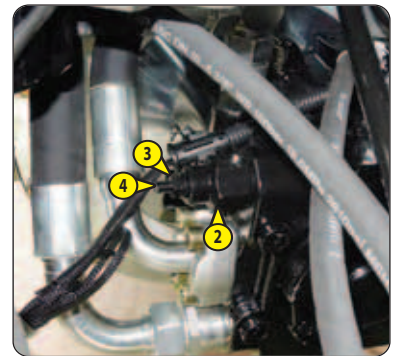

SLING

Lift truck

- Take into account the position of the lift truck centre of gravity for lifting.
- A = 1474 mm B = 1019 mm
- Place the slinging hooks in the anchorage points provided.

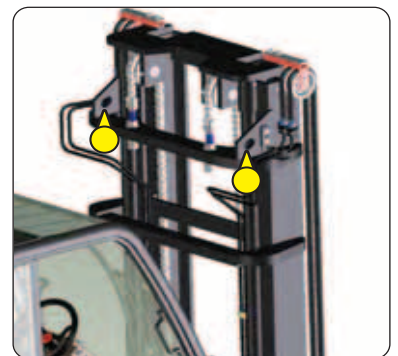
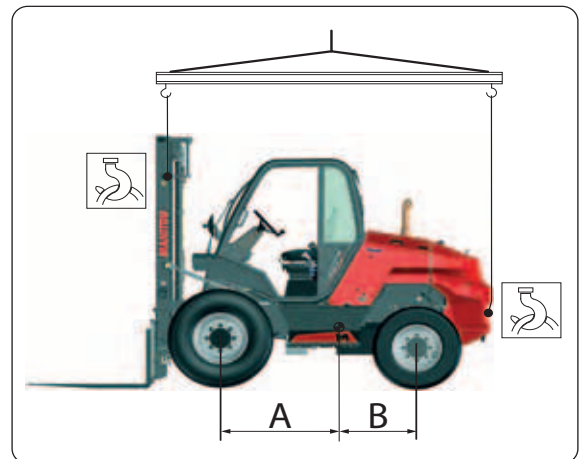

TRANSPORT

Lift truck

⚠ IMPORTANT ⚠

Check that the safety instructions relating to the flatbed have been correctly applied before loading the lift truck and that the transport company is informed about the dimensions and the weight of the lift truck (⚠ 2 - DESCRIPTION: SPECIFICATIONS).

Ensure that the flatbed is of sufficient size and load capacity for transporting the lift truck.
Also check the allowable ground contact pressure of the platform relative to the lift truck.

LOADING THE LIFT TRUCK

- Block the wheels of the platform.
- Attach the loading ramps to the platform in such a way as to give the shallowest possible ramp angle for the lift truck.
- Load the lift truck parallel to the platform.
- Stop the lift truck (⚠ 1 - OPERATING AND SAFETY INSTRUCTIONS: OPERATING INSTRUCTIONS WITH AND WITHOUT LOAD).

STOWING THE LIFT TRUCK

- Fix the chocks to the flatbed at the front and at the back of each tyre.
- Also fix the chocks to the flatbed on the inside of each tyre.
- Secure the lift truck to the platform with sufficiently strong straps:
 - At the front, at the foot of the mast, to the anchorage points 1
 - At the rear, to the anchorage points 2
 - Tighten the straps

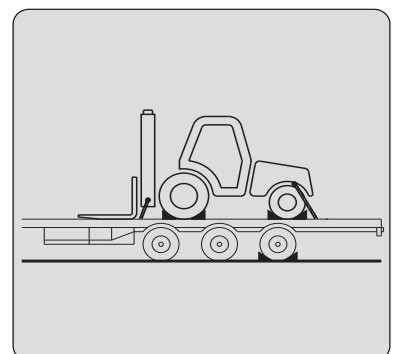
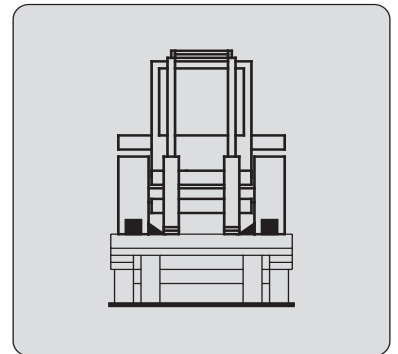
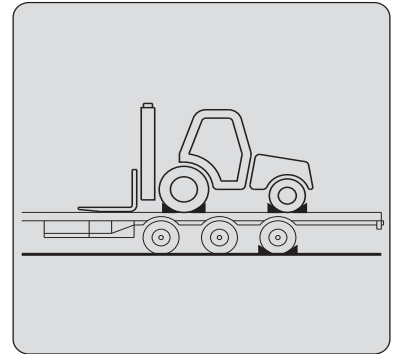



4 - ATTACHMENTS





4 - ATTACHMENTS

<u>INTRODUCTION</u>	4-3
<u>TECHNICAL SPECIFICATIONS OF ATTACHMENTS</u>	4-4
<u>ATTACHMENT GUARDS</u>	4-5

INTRODUCTION

Your lift truck must be used with interchangeable equipment. These items are called: ATTACHMENTS.

A wide range of attachments is available, guaranteed by MANITOU and designed to fit your lift truck perfectly.

⚠ IMPORTANT ⚠

Only attachments approved by MANITOU can be used on its lift trucks (↪ TECHNICAL SPECIFICATIONS OF ATTACHMENTS).

The manufacturer cannot be held responsible for any modifications or adaptations to attachments without its knowledge.

- The attachments are delivered with a load chart concerning your lift truck. The operator's manual and the load chart should be kept in the places provided in the lift truck. For standard attachments, their use is governed by the instructions contained on this notice.

⚠ IMPORTANT ⚠

Maximum loads are defined by the capacity of a lift truck taking account of the attachment's weight and center of gravity.

Should the attachment have a lower capacity than the lift truck, never exceed this limit.

- Some particular uses require the adaptation of the attachment which is not provided in the price-listed options. Solutions exist, consult your dealer.

SUSPENDED LOAD

⚠ IMPORTANT ⚠

*Suspended loads **MUST** be handled with a lift truck designed for this purpose.*

TECHNICAL SPECIFICATIONS OF ATTACHMENTS

STANDARDIZED FORK

	PART NO.	415522	415568
Section		150 x 70 x 1500 mm	150 x 70 x 1200 mm
Weight		156 kg	128 kg
	PART NO.	415978	415977
Section		200 x 60 x 1500 mm	200 x 60 x 1200 mm
Weight		202 kg	174 kg

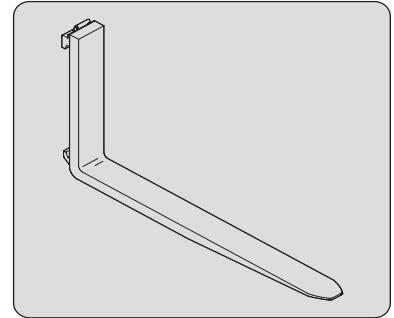

LOAD BACK REST

	PART NO.	252108	252109	252110
Width		1750 mm	2000 mm	2400 mm
Weight		206 kg	220 kg	256 kg

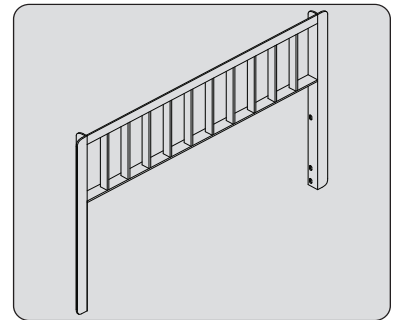

STANDARDISED SIDE-SHIFT CARRIAGE

	PART NO.	TDL 6T151P2 L1800	TDL 6T151P2 L2000
Rated capacity		8000 kg	8000 kg
Side-shift		2 x 160 mm	2 x 160 mm
Width		1800 mm	2000 mm
Weight		395 kg	425 kg

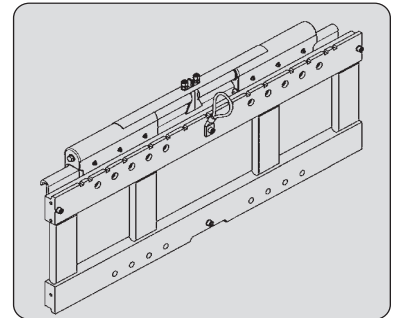

TILTING FORK CARRIAGE

	PART NO.	PFB 60 N TI L1750	PFB 60 N TI L2000
Width		1750 mm	2000 mm
Weight		388 kg	435 kg

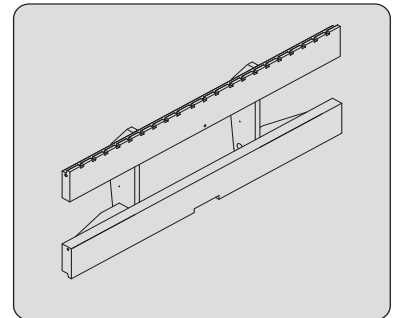



ATTACHMENT GUARDS

FORK GUARD

PART NO.

227801

