



Original instructions

Electric trucks

RX60-35/600

RX60-40

RX60-40/600

RX60-45

RX60-45/600

RX60-50

RX60-50/600



6327 6328 6329 6330 6367
6368 6369

171533 EN - 02/2019 - 19

first in intralogistics



Preface

Address of manufacturer and contact details ▷

STILL GmbH
Berzeliusstraße 10
22113 Hamburg, Germany
Tel. +49 (0) 40 7339-0
Fax: +49 (0) 40 7339-1622
Email: info@still.de
Website: <http://www.still.de>



Rules for the operating company of industrial trucks

In addition to these operating instructions, a code of practice containing additional information for the operating companies of industrial trucks is also available.

This guide provides information for handling industrial trucks:

- Information on how to select suitable industrial trucks for a particular area of application
- Prerequisites for the safe operation of industrial trucks
- Information on the use of industrial trucks
- Information on transport, initial commissioning and storage of industrial trucks

Internet address and QR code ▷

The information can be accessed at any time by pasting the address <https://m.still.de/vdma> in a web browser or by scanning the QR code.

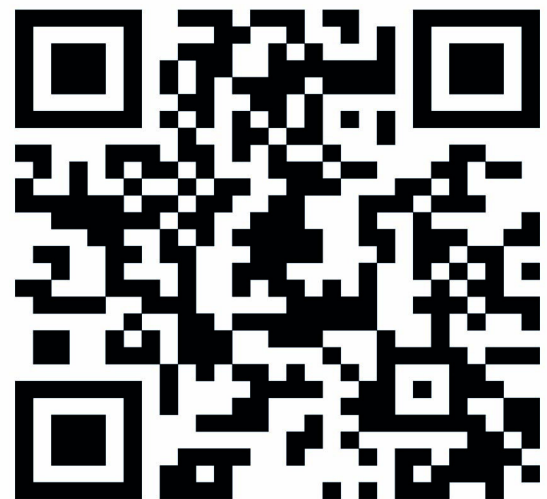





Table of contents

1 Foreword

Your truck	2
Description of the truck	2
General	4
CE labelling	5
EC declaration of conformity in accordance with Machinery Directive	6
Accessories	7
Labelling points	8
Nameplate	10
Production number	10
StVZO (Road Traffic Licensing Regulations) information	11
Nameplate of a lithium-ion battery	11
Using the truck	11
Commissioning	11
Proper usage	12
Proper use during towing	12
Impermissible use	13
Place of use	13
Parking in temperatures below -10°C	14
Using working platforms	15
Information about the documentation	16
Documentation scope	16
Supplementary documentation	17
Issue date and topicality of the operating instructions	18
Copyright and trademark rights	18
Explanation of information symbols used	18
List of abbreviations	19
Definition of directions	21
Schematic views	21
Environmental considerations	23
Packaging	23
Disposal of components and batteries	23

2 Safety

Definition of responsible persons	26
Operating company	26
Specialist	26
Drivers	27
Basic principles for safe operation	29
Insurance cover on company premises	29



Table of contents

Special features when using lithium-ion batteries (variant)	30
Changes and retrofitting	33
Changes to the overhead guard and roof loads	36
Warning regarding non-original parts	36
Damage, defects and misuse of safety systems	37
Tyres	37
Medical equipment	38
Exercise caution when handling gas springs and accumulators	39
Length of the fork arms	39
Residual risk	41
Residual dangers, residual risks	41
Special risks associated with using the truck and attachments	42
Overview of hazards and countermeasures	44
Danger to employees	47
Safety tests	48
Regular safety inspection of the truck	48
Insulation testing	48
Safety regulations for handling consumables	50
Permissible consumables	50
Oils	50
Hydraulic fluid	51
Battery acid	52
Disposal of consumables	53
Emissions	54
3 Overviews	
General view	58
General view of driver's compartment	60
Shelves and cup holders	61
Operating devices and display elements	62
Display operating unit	62
Lithium-ion battery display	63
Operating devices for hydraulic and traction functions	64
Multi-lever	65
Double mini-lever	66
Three-way mini-lever	67
Four-way mini-lever	68
Joystick 4Plus	69
Fingertip	70



Table of contents

Mini console	71
4 Operation	
Checks and tasks before daily use	74
Visual inspections and function checking	74
Climbing into and out of the truck	77
Adjusting the MSG 65/MSG 75 driver's seat	78
Seat belt	82
Adjusting the armrest	85
Adjusting the steering column	86
Unlocking the emergency off switch	87
Operating the signal horn	88
Driver's cab	89
Checking the brake system for correct function	90
Checking the steering system for correct function	93
Checking the emergency off function	94
Checking the vertical lift mast position (variant) for correct function	95
Zero adjustment of the load measurement (variant)	95
Switching on	97
Switching on the key switch	97
Access authorisation with PIN code (variant)	99
Display-operating unit	109
Indicators	109
Adjusting the displays	111
Symbols in the display	113
Setting the date or time	118
Resetting the daily kilometres and daily operating hours	118
Setting the language	119
Softkeys for operating various equipment variants	119
Blue-Q efficiency mode	121
Functional description	121
Switching off additional consumers	122
Switching efficiency mode Blue-Q on and off	122
Configuring Blue-Q efficiency mode	123
Driving	125
Safety regulations when driving	125
Driveways	127
Setting the drive programs	130
Sprint mode (variant)	132
Selecting the drive direction	133



Table of contents

Actuating the drive direction switch, multiple-lever version	134
Actuating the drive direction switch, mini-lever version	134
Actuating the vertical rocker switch for the "drive direction", joystick 4Plus version	135
Actuate the drive direction switch, fingertip version	135
Actuating the drive direction switch, mini-console version	136
Starting drive mode	136
Starting drive mode, dual-pedal version (variant)	138
Operating the service brake	141
Parking brake	142
Actuating the mechanical parking brake	142
Actuate the electric parking brake	144
Malfunctions in the electric parking brake	150
Steering	157
Reducing speed when turning (Curve Speed Control)	158
Reducing speed with a raised load (variant)	159
Parking	160
Parking the truck securely and switching it off	160
Wheel chock (variant)	161
Lifting	162
Lifting system variants	162
Types of lift mast	162
Lifting system operating devices	163
Multi-lever lifting system	164
Controlling the lifting system using a double mini-lever	165
Controlling the lifting system using a triple mini-lever	166
Controlling the lifting system using a quadruple mini-lever	167
Controlling the lifting system using the joystick 4Plus	168
Controlling the lifting system with the fingertip console	170
Changing the fork arms	171
Fork extension (variant)	173
Operation with reversible fork arms (variant)	175
Malfunctions during lifting mode	176
Hydraulic blocking function	177
Automatic lift cut out (variant)	178
Lift mast vertical position (variant)	179
Handling loads	184
Safety regulations when handling loads	184
Before taking up load	185
Load measurement (variant)	186
Picking up loads	189
Danger area	190



Table of contents

Transporting pallets	191
Transporting suspended loads	191
Load pick up	192
Transporting loads	196
Setting down loads	197
Driving on ascending and descending gradients	199
Driving on lifts	200
Driving on loading bridges	201
Attachments	202
Fitting attachments	202
Releasing the pressure from the hydraulic system	204
General instructions for controlling attachments	208
Controlling attachments using multi-lever operation	210
Operating attachments using multi-lever controls and the 5th function	211
Controlling attachments using a double mini-lever	213
Controlling attachments using the double mini-lever and the 5th function	215
Controlling attachments using a triple mini-lever	217
Controlling attachments using the triple mini-lever and the 5th function	219
Controlling attachments using a quadruple mini-lever	221
Controlling attachments using the quadruple mini-lever and the 5th function	223
Controlling attachments using the Joystick 4Plus	225
Controlling attachments with Joystick 4Plus and the 5th function	227
Controlling the attachments with fingertip	229
Controlling attachments with fingertip and the 5th function	230
Clamp locking mechanism (variant)	232
Taking up a load using attachments	236
Auxiliary equipment	237
Switching the lighting on and off	237
Switching the working spotlight for reverse travel on and off	238
Switching the rotating beacon on and off	238
Switching the hazard warning system on and off	239
Switching the turn indicators on and off	239
Switching the double working spotlights on and off.	242
STILL SafetyLight (variant)	244
Operating the windscreen wiper/washer	245
Filling the washer system	245
FleetManager (variant)	246
Shock recognition (variant)	246
Driver restraint systems (variants)	246
Ceiling sensor (variant)	247



Table of contents

Cab	253
Opening the cab door	253
Closing the cab door	254
Opening the side windows	254
Closing the side windows	254
Operating the interior lighting	255
Operating the rear window heating	256
Radio (variant)	256
Heating system (variant)	257
Push-up roof window (variant)	259
Clipboard (variant)	260
Trailer operation	261
Towed load	261
Coupling pin in the counterweight	262
Automatic tow coupling	264
Towing trailers	272
Cold store application	274
Display messages	277
Display content	277
Error code table	277
General messages	282
Drive-specific messages	291
Procedure in emergencies	295
Emergency shutdown	295
Procedure if truck tips over	296
Emergency hammer	297
Emergency lowering	297
Emergency operation of the electric parking brake	299
Towing	300
Connecting and disconnecting the battery male connector	303
Connecting the battery male connector	303
Disconnecting the battery male connector	304
Handling the lead-acid battery	305
Safety regulations for handling the battery	305
Maintaining the battery	308
Checking the battery condition, acid level and acid density	310
Checking the battery charge status	311
Charging the battery	311
Charging the battery with the battery charging flap	314
Equalising charging to preserve the battery capacity	318

Table of contents

Handling the lithium-ion battery	321
Safety regulations for handling the lithium-ion battery	321
Lithium-ion batteries "GGS Li-Ion 80 V BG 7"36.2 kWh and 118.4 kWh	324
Display messages on the display-operating unit	325
Regulations for storing lithium-ion batteries	325
Checking the battery charge state	328
Charging the battery	331
Replacing and transporting the battery	333
General information on replacing the battery	333
Changing to a different battery type	334
Opening/closing the battery cover	334
Special notes for installing the lithium-ion battery	337
Replacing the battery using forklift truck or pallet truck	338
Replacing the battery using a change frame (variant)	341
Replacing the battery with the hydraulic battery carrier	345
Transporting the lead-acid battery by crane	353
Transporting the lithium-ion battery by crane	354
Cleaning the truck	355
Cleaning the truck	355
Cleaning the electrical system	357
Clean load chains	357
Cleaning the windows	358
After cleaning	358
Transporting the truck	360
Transport	360
Crane loading	362
Decommissioning	366
Decommissioning and storing the truck	366
Returning to service after decommissioning	368
5 Maintenance	
Safety regulations for maintenance	372
General information	372
Working on the hydraulic equipment	372
Working on the electrical equipment	372
Safety devices	373
Set values	373
Lifting and jacking up	373
Working at the front of the truck	374



Table of contents

General maintenance information	376
Personnel qualifications	376
Information for carrying out maintenance	376
Maintenance — 1000 hours/annually	379
Maintenance - 3000 hours/every two years	383
Ordering spare parts and wearing parts	383
Quality and quantity of the required operating materials	383
Lubrication plan	385
Maintenance data table	387
Providing access to maintenance points	390
Removing and installing the valve cover	390
Opening the fuse box	390
Preserving operational readiness	392
Lubricating the joints and controls	392
Checking the battery interlock and battery cover	392
Maintaining the seat belt	394
Checking the driver's seat	395
Maintaining wheels and tyres	396
Servicing the steering axle	398
Checking the battery	400
Checking the fuses	400
Replacing fuses	402
Checking the hydraulic oil level	404
Checking the hydraulic system for leak tightness	405
Lubricating the lift mast and roller track	406
Greasing the automatic tow coupling	406
Preserving operational readiness for cold store application	409
Maintaining the heater	409
1000-hour maintenance/yearly maintenance	411
Other tasks	411
Checking the cable connections	411
Checking the hydraulic oil level of the hydraulic battery carrier	411
Lubricating the slide elements	413
Oiling the catch rails	413
Checking the lift cylinders and connections for leaks	415
Checking fork arms	416
Checking the reversible fork arms	416
Checking the double pedal	417
Checking the battery changeover frame	417



Table of contents

6 Technical data

Dimensions	420
VDI datasheet RX60-35/600	422
VDI datasheet RX60-40 and RX60-40/600	426
VDI datasheet RX60-45 and RX60-45/600	430
VDI datasheet RX60-50 and RX60-50/600	434
Ergonomic dimensions	438
Information about the lead-acid battery	439
Information about the lithium-ion battery	441
Fuse assignment	442
Fuse assignment standard equipment	442
Fuse assignment equipment variants	443





1

Foreword



Your truck

Your truck

Description of the truck

General

The STILL RX60 35-50 is an electrically driven counterbalanced truck with a rear swing axle. The truck has a load capacity of up to 5.0 tonnes. Alternatively, a load capacity of up to 3.0 tonnes, 4.0 tonnes, 4.5 tonnes or 5.0 tonnes with a load centre of gravity of 600 mm is available. The truck can reach driving speeds of up to 20 km/h without a load.

It is suitable for interior use and for outdoor use.

The display-operating unit manages all functions that are not called up by the operating devices for drive functions and hydraulic functions. All messages and driving condition information are issued via the display. The display-operating unit uses the current battery charge state and the selected drive program to calculate the remaining available time until the battery has to be recharged and displays this information.

The truck supports all functions of FleetManager 4.0 (variant).

Brake system

The brake system of the truck is comprised of three different brakes:

- Service brake
- Regenerative brake
- Mechanically actuated parking brake
- Electrically actuated parking brake (variant)

The service brake is based on a wear-free, oil-immersed multi-disc brake. This multi-disc brake is used as the service brake for heavy braking or emergency braking with the brake pedal. In the normal working mode, the regenerative brake of the electric traction motors takes effect. The regenerative brake converts the acceleration energy of the truck into electrical energy. This causes the truck to decelerate as soon as the accelerator pedal is released. Completely removing your foot from the accelerator pedal causes the truck to



brake until it comes to a standstill. A parking brake ensures that the truck remains securely in place when parked.

Hydraulic system

The steering system, the lift cylinders and the tilt cylinders in the lift mast are supplied with power via a hydraulic pump operated by an electric motor.

The proportional valve technology provides particularly sensitive movements and safe handling of the load. The hydraulic functions can be parameterised individually by the authorised service centre.

Up to three hydraulic circuits can be used to activate attachments (variant). Depending on the equipment, a hydraulic accumulator is also available in the lifting circuit for the purpose of damping pressure peaks in the hydraulic system.

Drive

The STILL RX60 35-50 is driven via both front wheels by maintenance-free three-phase drives in the front axle with 80 volt technology.

Power is supplied by lead-acid batteries or lithium-ion batteries. The batteries are located at the side of the truck to enable easy replacement. In both cases, the trucks can be supplied as a cold store variant.

The driver can help to influence the energy consumption and performance of the truck using the "Blue-Q" efficiency mode, which allows the required setting for each current application to be called up via the display-operating unit.

Steering

The kickback-free, hydraulic rear-wheel steering with "Curve Speed Control" (CSC) ensures driving stability when cornering, allowing the truck to achieve a small turning circle and negotiate narrow aisle widths.



Your truck

Operation

A multi-lever, Fingertip, mini-lever and the Joystick 4Plus are available as operating devices for the hydraulic functions. These operating devices enable precise operation and smooth control of the lifting speed thanks to directly controlled valves and proportional valve technology.

For drive mode, the truck features either single-pedal or dual-pedal operation. The accelerator pedal is used to accelerate and brake (electric brake) the truck. In emergency situations or when carrying heavy loads, the driver can also brake the truck using the service brake by pressing the brake pedal. In dual-pedal operation, the truck has one pedal for the "Forwards" drive direction and one pedal for the "Reverse" drive direction. Acceleration and braking behaviour can be individually selected from five different drive programmes.

The display-operating unit monitors the truck functions, including each individual cell in the lithium-ion battery.

General

The truck described in these operating instructions corresponds to the applicable standards and safety regulations.

If the truck is to be operated on public roads, it must conform to the existing national regulations for the country in which it is being used. The driving permit must be obtained from the appropriate office.

The truck has been fitted with state-of-the-art technology. Following these operating instructions will allow the truck to be handled safely. By complying with the specifications in these operating instructions, the functionality and the approved features of the truck will be retained.

Get to know the technology, understand it and use it safely - these operating instructions provide the necessary information and help to avoid accidents and to keep the truck ready for operation beyond the warranty period.

Therefore:

- Before commissioning the truck, read the operating instructions and follow the instructions.
- Always follow all of the safety information contained in the operating instructions and on the truck.

CE labelling

The manufacturer uses CE labelling to indicate that the truck complies with the standards and regulations valid at the time of marketing. This is confirmed by the issued EC declaration of conformity. The CE labelling is attached to the nameplate.

An independent structural change or addition to the truck can compromise safety, thus invalidating the EC declaration of conformity.

The EC declaration of conformity must be carefully stored and made available to the responsible authorities.

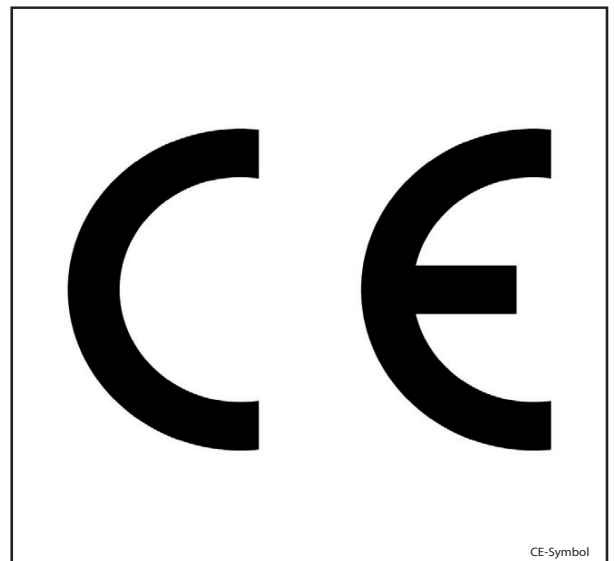

EC declaration of conformity in accordance with Machinery Directive

Declaration

STILL GmbH
Berzeliusstraße 10
D-22113 Hamburg Germany

We declare that the

Industrial truck	according to these operating instructions
Model	according to these operating instructions

conforms to the latest version of the Machinery Directive 2006/42/EC.

Personnel authorised to compile the technical documents:

See EC compliance declaration

STILL GmbH



Accessories

- Key for key switch (2 pieces)
- Key for cab (variant)
- Hexagon socket wrench for emergency lowering
- Battery replacement frame

1 Foreword

Your truck

Labelling points

1 Forklift operation symbol (forward and reverse arrows)

2 Warning symbol (exclamation mark) and manual symbol (open book)

3 DANGER symbol: No entry

4 DANGER symbol: No hand

5 DANGER symbol: No hand

6 DANGER symbol: No person

7 DANGER symbol: No person

8 DANGER symbol: No person

9 DANGER symbol: No person

10 Parking symbol (P in a circle with arrows)

11 Parking symbol (P in a circle with arrows)

12 STOP symbol (STOP in a circle with arrows)

13 DANGER symbol: No hand

14 Hook symbol

15 Hook symbol

16 Oil symbol (oil drop)

17 STILL GmbH Hamburg logo and inspection details

18 Inspection details: Leergewicht-StVZO, Zul. Gesamtgewicht, Zul. Achslasten, Nutzlast

19 Inspection details: 20xx

20 Forklift operation symbol (forward and reverse arrows)

21 Forklift operation symbol (forward and reverse arrows)

22 Arrow symbol (right)

23 CE mark and technical specifications table

24 Technical specifications table

25 Technical specifications table

26 Inspection details: STVZO-Angaben

27 Inspection details: Nächste Prüfung

28 Warning symbol (exclamation mark) and manual symbol (open book)



1	Decal information: Fasten the seat belt	16	Decal information: Hydraulic oil tank
2	Decal information: Caution / Read the operating instructions	17	Decal information: FEM audit
3	Warning sign: Passengers are not allowed	18	Manufacturer's label text
4	Warning sign: Danger due to shearing	19	Manufacturer's label text
5	Warning sign: Danger due to high fluid pressure	20	Decal information: Ceiling sensor (next to the display-operating unit)
6	Warning sign: Do not stand underneath the fork	21	Manufacturer's label text
7	Warning sign: Do not stand on the fork	22	Decal information: Unlocking
8	Warning sign: Risk of short circuit due to shearing	23	Nameplate
9	Decal information: Do not jump off if the truck is tipping over / Lean in the opposite direction to which the truck is tipping	24	Capacity rating plate
10	Decal information: Parking brake released	25	Production number
11	Decal information: Parking brake applied	26	Decal information: StVZO (German Road Traffic Licensing Regulations) information
12	Decal information: "Dual-pedal operation"	27	Decal information: Battery service
13	Warning sign: Danger due to shearing	28	Decal information: Caution / Read the operating instructions / Fasten the seat belt / Apply parking brake when leaving the truck / Passengers are not allowed / Do not jump off if the truck is tipping over / Lean in the opposite direction to which the truck is tipping
14	Decal information: Lifting gear attachment point		
15	Decal information: Lifting gear attachment point		

1

Foreword

Your truck

Nameplate

The truck can be identified from the information on the nameplate.

The information for the battery weights (5, 6) and the ballast weight (7) only applies to electric forklift trucks.

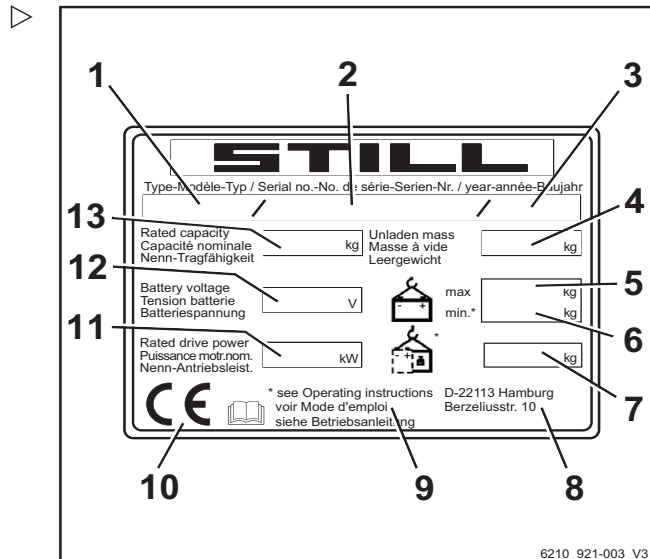

- 1 Type
- 2 Production number
- 3 Year of manufacture
- 4 Tare weight in kg
- 5 Max. permissible battery weight in kg
- 6 Min. permissible battery weight in kg
- 7 Ballast weight in kg
- 8 Address of manufacturer
- 9 Refer to the technical data listed in these operating instructions for more detailed information
- 10 CE labelling
- 11 Nominal drive power in kW
- 12 Battery voltage in V
- 13 Rated capacity in kg

Production number

i NOTE

The production number is used to identify the truck. It can be found on the nameplate and must be referred to in all technical questions.

The production number contains the following coded information:

- (1) Production location
- (2) Model
- (3) Year of manufacture
- (4) Sequential number

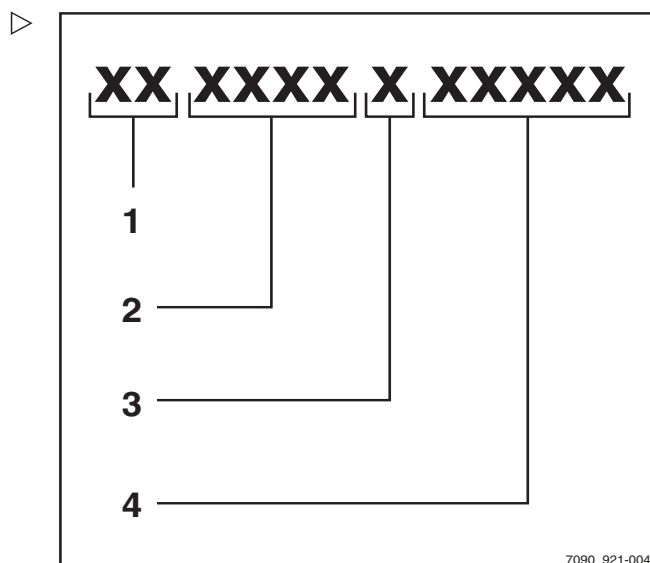



Using the truck

The necessary steps for the commissioning vary depending on the model and equipment of the truck. These steps require preparatory work and adjustment work that cannot be performed by the operating company. See also the chapter entitled "Definition of responsible persons".

- To commission the truck, contact the authorised service centre.

Proper usage

The truck described in these operating instructions is suitable for lifting, transporting and stacking loads.

The truck may only be used for its proper purpose as set out and described in these operating instructions.

If the truck is to be used for purposes other than those specified in the operating instructions, the approval of the manufacturer and, if applicable, the relevant regulatory authorities must be obtained beforehand to prevent hazards.

The maximum load to be lifted is specified on the capacity rating plate (load diagram) and must not be exceeded; see also the chapter entitled "Before picking up a load".

Proper use during towing

This truck is suitable for the occasional towing of trailers and is equipped with a towing device for this purpose. This occasional towing may not exceed 2% of the daily operating time. If the truck is to be used for towing on a more regular basis, the manufacturer should be consulted.

The regulations regarding trailer operation must be observed; see chapter "Trailer operation".

Impermissible use

The operating company or driver, and not the manufacturer, is liable for any hazards caused by improper use.

NOTE

Please observe the definition of the following responsible persons: "operating company" and "driver".

Use for purposes other than those described in these operating instructions is prohibited.



DANGER

There is a risk of fatal injury from falling off the truck while it is moving!

- It is prohibited to carry passengers on the truck.

The truck may not be operated in areas where there is a risk of fire, explosion or corrosion, or in areas that are particularly dusty.

Stacking or unstacking is not permissible on inclined surfaces or ramps.

Place of use

The truck can be used both outside and in buildings. Operation on public roads is only permitted if the "StVZO" (German Road Traffic Licensing Regulations) equipment variant is installed.

If the truck is to be operated on public roads, the truck must conform to the national regulations for the country in which it is being used.

The ground must have an adequate load capacity (concrete, asphalt) and a rough surface. Roadways, working areas and aisle widths must conform to the specifications in these operating instructions; see the chapter entitled "Roadways".

Driving on upward and downward gradients is permitted provided the specified data and specifications are observed, see the "Routes" chapter.

Using the truck

The truck is suitable for indoor and outdoor use in countries ranging from the Tropics to Nordic regions (temperature range: -20°C to +40°C).

If the truck is to be used in a cold store, it must be configured accordingly and, if necessary, approved for such an environment; see the chapter entitled "Cold store application".

⚠ CAUTION

Batteries can freeze!

If the truck is parked in an ambient temperature of below -10°C for an extended period, the batteries will cool down. The electrolyte may freeze and damage the batteries. The truck is then not ready for operation.

- At ambient temperatures of below -10°C, only park the truck for short periods of time.

The operating company must ensure suitable fire protection for the relevant application in the truck's surroundings. Depending on the application, additional fire protection must be provided on the truck. If in doubt, contact the relevant authorities.

i NOTE

Please observe the definition of the following responsible person: "operating company".

Parking in temperatures below -10°C

⚠ CAUTION

Batteries can freeze!

If the truck is parked in an ambient temperature below -10°C for an extended period, the batteries will cool down. The electrolyte may freeze and damage the batteries. The truck is then not ready for operation.

- When the ambient temperature is below -10°C, only park the truck for short periods of time.



Using working platforms

WARNING

The use of working platforms is regulated by national law. The use of working platforms is only permitted by virtue of the jurisdiction in the country of use.

- Observe national legislation.
 - Before using working platforms, consult the national regulatory authorities.
-

Information about the documentation

Information about the documentation

Documentation scope

- Original operating instructions
- Original operating instructions for attachments (variant)
- Spare parts list
- Depending on the truck equipment, "UPA" operating instructions may also be provided

NOTE

Refer to the additional information in the section entitled "Rules for the operating company of industrial trucks".

These operating instructions describe all measures necessary for the safe operation and proper maintenance of the truck in all possible variants available at the time of printing. Special versions to meet customer requirements (UPA) are documented in separate operating instructions. If you have any questions, please contact your authorised service centre.

Enter the production number and year of manufacture from the nameplate in the space provided:

Production number:

Year of manufacture:

Please quote the production number in all technical enquiries.

Each truck comes with a set of operating instructions. These instructions must be stored carefully and must be available to the driver and operating company at all times. The storage location is specified in the chapter entitled "Overviews".

If the operating instructions are lost, the operating company must obtain a replacement from the manufacturer immediately.

The operating instructions are included in the spare parts list and can be reordered as a spare part.

The personnel responsible for operating and maintaining the equipment must be familiar with these operating instructions.

The operating company must ensure that all users have received, read and understood these operating instructions.

Safely store the complete documentation and pass on to the subsequent operating company when transferring or selling the truck.

 **NOTE**

Please observe the definition of the following responsible persons: "operating company" and "driver".

Thank you for reading and complying with these operating instructions. If you have any questions or suggestions for improvements, or if you have found any errors, please contact the authorised service centre.

Supplementary documentation

This industrial truck can be fitted with un-planned equipment (UPA) that deviates from the standard equipment and/or the variants.

The UPA may be, for example:

- Special sensors
- Special attachments
- Towing devices
- Customised attachments

In this case, the industrial truck has additional documentation. This may be in the form of an insert or separate operating instructions.

The original operating instructions for this industrial truck are valid for the operation of standard equipment and variants without restriction. The operational and safety information in the original operating instructions continues to be valid in its entirety unless it is countermanded in this additional documentation.

The requirements for the qualification of personnel as well as the time for maintenance

Information about the documentation

may vary. This is defined in the additional documentation.

- If you have any questions, please contact your authorised service centre.

Issue date and topicality of the operating instructions

The issue date of these operating instructions can be found on the title page.

STILL is constantly engaged in the further development of trucks. These operating instructions are subject to change, and any claims based on the information and/or illustrations contained in them cannot be asserted.

Please contact your authorised service centre for technical support relating to your truck.

Copyright and trademark rights

These instructions must not be reproduced, translated or made accessible to third parties—including as excerpts—except with the express written approval of the manufacturer.

Explanation of information symbols used

DANGER

Indicates procedures that must be strictly adhered to in order to prevent the risk of fatalities.

WARNING

Indicates procedures that must be strictly adhered to in order to prevent the risk of injuries.

CAUTION

Indicates procedures that must be strictly adhered to in order to prevent material damage and/or destruction.

 **NOTE**

For technical requirements that require special attention.

 **ENVIRONMENT NOTE**

To prevent environmental damage.

List of abbreviations

 **NOTE**

This list of abbreviations applies to all types of operating instructions. Not all of the abbreviations that are listed here will necessarily appear in these operating instructions.

Abbreviation	Meaning	Explanation
ABE	Display operating unit	
ArbSchG	Arbeitsschutzgesetz	German implementation of EU occupational health and safety directives
BetrSichV	Betriebssicherheitsverordnung	German implementation of the EU working equipment directive
BG	Berufsgenossenschaft	German insurance company for the company and employees
BGG	Berufsgenossenschaftlicher Grundsatz	German principles and test specifications for occupational health and safety
BGR	Berufsgenossenschaftliche Regel	German rules and recommendations for occupational health and safety
DGUV	Berufsgenossenschaftliche Vorschrift	German accident prevention regulations
CE	Communauté Européenne	Confirms conformity with product-specific European directives (CE mark)
CEE	Commission on the Rules for the Approval of the Electrical Equipment	International commission on the rules for the approval of electrical equipment
DC	Direct Current	Direct current
DFÜ	Datenfernübertragung	Remote data transmission
DIN	Deutsches Institut für Normung	German standardisation organisation
EG	European Community	
EN	European standard	
FEM	Fédération Européenne de la Manutention	European Federation of Materials Handling and Storage Equipment
F _{max}	maximum Force	Maximum power



1 Foreword

Information about the documentation

Abbreviation	Meaning	Explanation
GAA	Gewerbeaufsichtsamt	German authority for monitoring/issuing regulations for worker protection, environmental protection, and consumer protection
GPRS	General Packet Radio Service	Transfer of data packets in wireless networks
ID no.	ID number	
ISO	International Organization for Standardization	International standardisation organisation
LAN	Local Area Network	Local area network
K _{pA}	Uncertainty of measurement of sound pressure levels	
LED	Light Emitting Diode	Light emitting diode
L _p	Sound pressure level at the workplace	
L _{pAZ}	Average continuous sound pressure level in the driver's compartment	
LSP	Load centre of gravity	Distance of the centre of gravity of the load from the front face of the fork backs
MAK	Maximum workplace concentration	Maximum permissible air concentrations of a substance at the workplace
Max.	Maximum	Highest value of an amount
Min.	Minimum	Lowest value of an amount
PIN	Personal Identification Number	Personal identification number
PPE	Personal protective equipment	
SE	Super-Elastic	Superelastic tyres (solid rubber tyres)
SIT	Snap-In Tyre	Tyres for simplified assembly, without loose rim parts
StVZO	Straßenverkehrs-Zulassungs-Ordnung	German regulations for approval of vehicles on public roads
TRGS	Technische Regel für Gefahrstoffe	Ordinance on hazardous materials applicable in the Federal Republic of Germany
VDE	Verband der Elektrotechnik Elektronik Informationstechnik	German technical/scientific association
VDI	Verein Deutscher Ingenieure	German technical/scientific association
VDMA	Verband Deutscher Maschinen- und Anlagenbau e.V.	German Mechanical Engineering Industry Association
WLAN	Wireless LAN	Wireless local area network

Definition of directions

The directions "forwards" (1), "backwards" (3), "right" (2) and "left" (4) refer to the installation position of the parts as seen from the driver's compartment; the load is to the front.

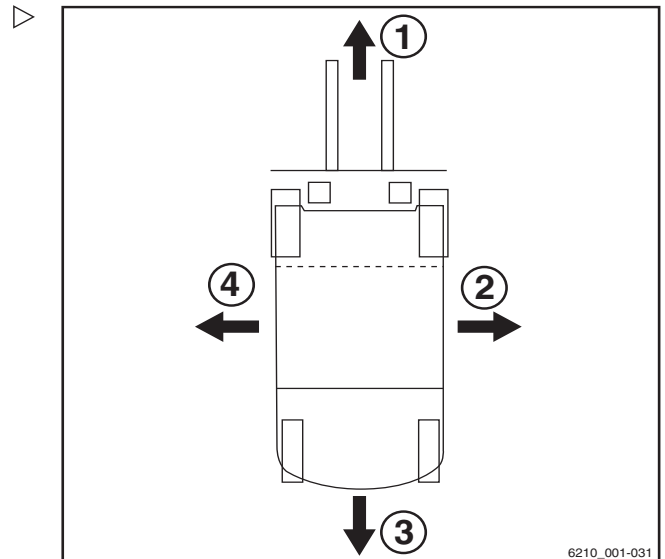

Schematic views

View of functions and operations

This documentation explains the (usually sequential) chain of certain functions or operations. Schematic diagrams of a counterbalance truck are used to illustrate these procedures.

i NOTE

These schematic diagrams are not representative of the structural state of the documented truck. The diagrams are used solely for the purpose of clarifying procedures.

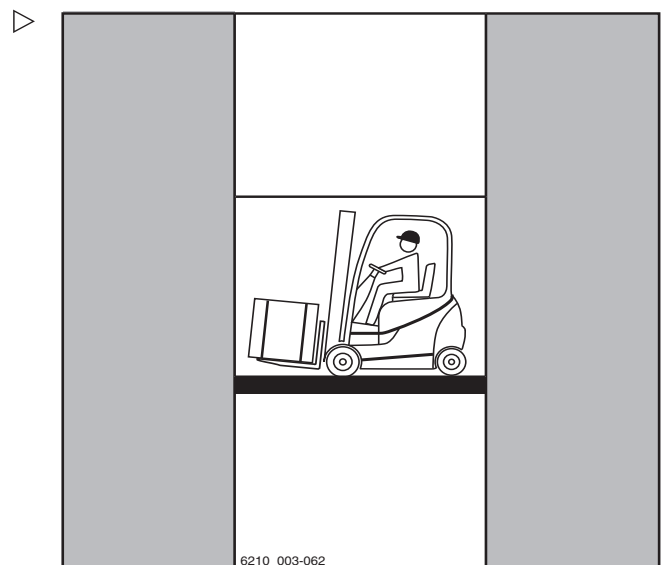

Information about the documentation

View of the display operating unit

i NOTE

Views of operating statuses and values in the display of the display operating unit are examples and partly dependent on the truck equipment. As a result, the displays shown of the actual operating statuses and values can vary. Information that is not relevant for descriptions is not shown.

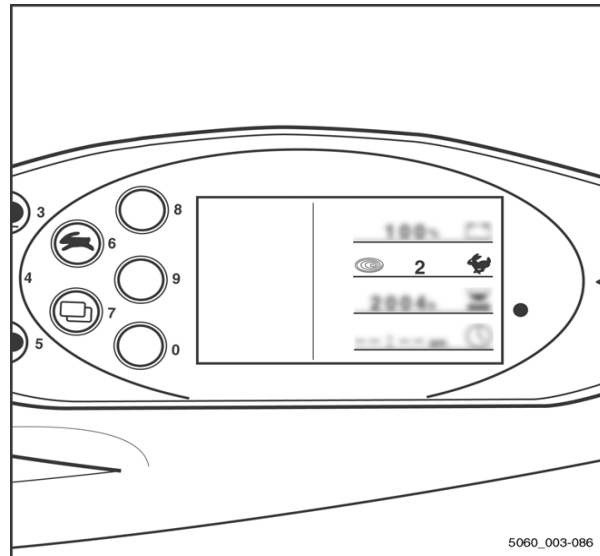

Environmental considerations

Packaging

During delivery of the truck, certain parts are packaged to provide protection during transport. This packaging must be removed completely prior to initial start-up.



ENVIRONMENT NOTE

The packaging material must be disposed of properly after delivery of the truck.

Disposal of components and batteries

The truck is composed of different materials. If components or batteries need to be replaced and disposed of, they must be:

- disposed of,
- treated or
- recycled in accordance with regional and national regulations.



NOTE

The documentation provided by the battery manufacturer must be observed when disposing of batteries.



ENVIRONMENT NOTE

We recommend working with a waste management company for disposal purposes.



1 Environmental considerations Foreword



2

Safety



Definition of responsible persons

Definition of responsible persons

Operating company

The operating company is the natural or legal person or group who operates the truck or on whose authority the truck is used.

The operating company must ensure that the truck is only used for its proper purpose and in compliance with the safety regulations set out in these operating instructions.

The operating company must ensure that all users read and understand the safety information.

The operating company is responsible for the scheduling and correct performance of regular safety checks.

We recommend that the national performance specifications are adhered to.

Specialist

A qualified person is defined as a service engineer or a person who fulfils the following requirements:

- A completed vocational qualification that demonstrably proves their professional expertise. This proof should consist of a vocational qualification or a similar document.
- Professional experience indicating that the qualified person has gained practical experience of industrial trucks over a proven period during their career. During this time, this person has become familiar with a wide range of symptoms that require checks to be carried out, such as based on the results of a hazard assessment or a daily inspection.
- Recent professional involvement in the field of the industrial truck test in question and an appropriate further qualification are essential. The qualified person must have experience of carrying out the test in question or of carrying out similar tests. Moreover, this person must be aware of the latest technological developments.



regarding the industrial truck to be tested and the risk being assessed

Drivers

This truck may only be driven by suitable persons who are at least 18 years of age, have been trained in driving, have demonstrated their skills in driving and handling loads to the operating company or an authorised representative, and have been specifically instructed to drive the truck. Specific knowledge of the truck to be operated is also required.

The training requirements under §3 of the Health and Safety at Work Act and §9 of the plant safety regulations are deemed to have been satisfied if the driver has been trained in accordance with BGG (General Employers' Liability Insurance Association Act) 925. Observe the national regulations for your country.

Driver rights, duties and rules of behaviour

The driver must be trained in his rights and duties.

The driver must be granted the required rights.

The driver must wear protective equipment (protection suit, safety footwear, safety helmet, industrial goggles and gloves) that is appropriate for the conditions, the job and the load to be lifted. Solid footwear should be worn to ensure safe driving and braking.

The driver must be familiar with the operating instructions and have access to them at all times.

The driver must:

- have read and understood the operating manual
- have familiarised himself with safe operation of the truck
- be physically and mentally able to drive the truck safely



Definition of responsible persons

⚠ DANGER

The use of drugs, alcohol or medications that affect reactions impair the ability to drive the truck!

Individuals under the influence of the aforementioned substances are not permitted to perform work of any kind on or with the truck.

Prohibition of use by unauthorised persons

The driver is responsible for the truck during working hours. He must not allow unauthorised persons to operate the truck.

When leaving the truck, the driver must secure it against unauthorised use, e.g. by pulling out the key.



Basic principles for safe operation

Insurance cover on company premises

In many cases, company premises are restricted public traffic areas.

 **NOTE**

The business liability insurance should be reviewed to ensure that, in the event of any damage caused in restricted public traffic areas, there is insurance cover for the truck in respect of third parties.

2 Safety

Basic principles for safe operation

Special features when using lithium-ion batteries (variant)

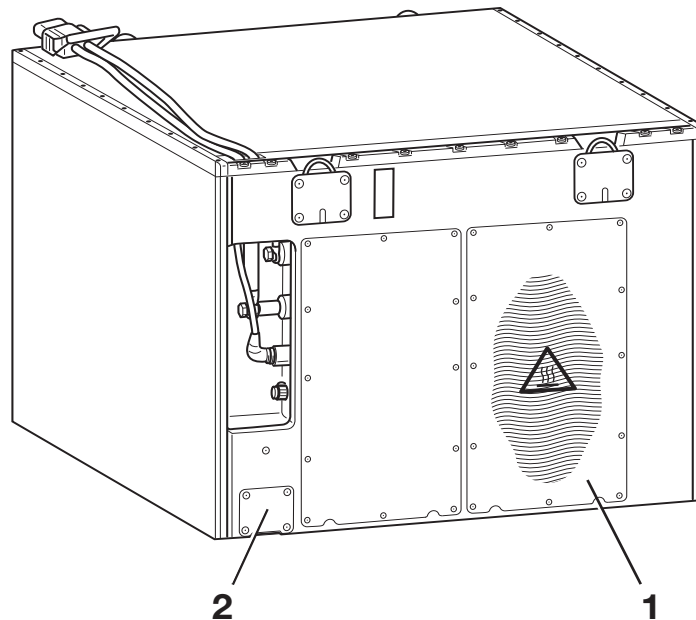

The following special features apply for the operating company and drivers when this truck is equipped with a lithium-ion battery (variant) in place of a conventional lead-acid battery.



⚠ DANGER

Risk of explosion!
Heating to over 80°C, mechanical stress and incorrect use may cause the battery to explode.

- Never heat the battery to over 80°C or expose it to naked flames.
- Do not subject the battery to excessive mechanical loads.
- Do not climb on the battery.
- Avoid impacts.
- Do not open the battery.
- Never short-circuit the battery connectors.
- Do not connect the battery with the polarity reversed.

Product-specific dangers of the 36.2-kWh and 118.4-kWh lithium-ion battery



⚠ WARNING

Risk of burns due to hot surfaces!

The battery has an integrated brake resistor that can heat up to over 100°C during operation.

It can take several hours of cooling down before a safe temperature is reached.

- Do not touch the hot area (1).

⚠ WARNING

Risk of injury!

If the safety valve (2) trips, there is a risk of injury!

- Exit the area around the battery immediately, retreating to a minimum distance of 5 m.

i NOTE

The brake resistor (1) is installed differently depending on the battery group. The build-up of heat in the area around the brake resistor is harmless. The safety valve (2) opens when the battery is subjected to over pressure or it catches fire.

All lithium-ion batteries are essentially associated with the risk of a fire starting, of the battery exploding and of the battery causing chemical burns.

When used as intended, no hazardous substances escape from the closed tray and contact with toxic substances will not occur. There is a risk of contact only in the event of incorrect use (mechanical, thermal, electrical) that leads to activation of the safety valve (2) or to the housing cracking. As a result, the electrolyte fluid may leak out, the electrode material may react with humidity/water, or battery discharge/a fire/or an explosion can occur, depending on the surrounding circumstances.

Touching live components can lead to an electric shock, which can have thermal or paralysing effects. The latter can cause ven-

Basic principles for safe operation

tricular fibrillation, cardiac arrest or respiratory paralysis, leading to death.

If a battery combusts, the resulting smoke or vapours can cause irritation of the eyes, the skin and the respiratory system.

Permissible lithium-ion batteries

- Use only lithium-ion batteries that have been approved by STILL for use with this truck.
- Contact the authorised service centre regarding this matter.

Declaring the use of lithium-ion batteries

We recommend that the operating company informs the local fire brigade of the planned use of trucks fitted with lithium-ion batteries.

The health and safety representative and the workforce must also be informed that trucks with lithium-ion batteries are being used.

Hazard assessment

In accordance with §3 of the German Ordinance on Industrial Safety and Health (BetrSichV), the operating company is obliged to perform a separate hazard assessment in order to assess the risks posed to the company by lithium-ion batteries.

- Observe the national regulations for the country in which the truck is being used.

Driver qualification

In addition to the prerequisites set out in the chapter entitled "Definition of responsible persons", in the section entitled "Driver", please observe the following:

- The driver must be instructed in how to operate the lithium-ion battery.
- Only trained drivers may drive these trucks.

Procedure in the event of a fire

Damaged lithium-ion batteries pose an increased fire hazard. In the event of a fire,



large quantities of water are the best option to cool the battery.

- Evacuate the location of the fire as quickly as possible.
- Ventilate the location of the fire well, as the resulting combustion gases are corrosive if inhaled.
- Inform the fire brigade that lithium-ion batteries are affected by the fire.
- Observe the information provided by the battery manufacturer regarding the procedure in the event of a fire.

Water can be used to cool down an incipient fire.

Transporting

In certain circumstances, transport of the lithium-ion battery outside the premises may require a special transport container.

- Contact the authorised service centre for more information.

Changes and retrofitting

If the truck will be used for work that is not listed in the directives or in these instructions, convert or retrofit the truck for this purpose as required. Any structural modification can impair the handling and stability of the truck, and can result in accidents.

Any modifications that adversely affect the stability, the load capacity or the circumferential view of the truck require written approval from the manufacturer.

The following components may only be modified with prior written approval from the manufacturer:

- Brakes
- Steering
- Operating devices
- Safety systems
- Equipment variants
- Attachments

Basic principles for safe operation

The truck may only be converted with written approval from the manufacturer. If necessary, obtain approval from the relevant authorities.

We warn against the installation and use of restraint systems not approved by the manufacturer.

- Contact the authorised service centre before converting or retrofitting the truck.



⚠ DANGER

Risk of injury if truck tips over!

Even if an approved restraint system is in use, there is still a residual risk that the driver could be injured if the truck tips over. The risk of injury can be reduced by using the restraint system in conjunction with the seat belt. In addition, the seat belt protects against the consequences of rear-end collisions and falling off ramps.

- Use the seat belt too.

Only the authorised service centre is permitted to perform welding work on the truck.



⚠ DANGER

Risk of explosion from additional bores in the battery hood!

Explosive gases can escape and can lead to potentially fatal injuries if they explode. Sealing bores with plugs is not sufficient to prevent gas from escaping.

- Do not drill any holes in the battery hood.

⚠ DANGER

Risk of accident from additional holes in the battery hood!

The rigidity of the battery hood is impaired and the battery hood can break. The driver's seat may collapse into the battery hood, which could cause the driver to perform uncontrolled steering and driving manoeuvres.

- Do not drill any holes in the battery hood.



⚠ DANGER

Risk to life from falling load!

There is a risk to the driver's life if the truck is not equipped with an overhead guard, as the driver may be struck by a load falling from a lift height of 1800 mm or greater.

Operation of the truck without an overhead guard is prohibited at a lift height greater than 1800 mm.

- At lift heights of 1800 mm and above, only use the truck in conjunction with an overhead guard.

The operating company is only permitted to make modifications to the truck independently if the manufacturer goes into liquidation and the company is not taken over by another legal person.

The operating company must also fulfil the following prerequisites:

- Design documents, test documents and assembly instructions associated with the modification must be permanently archived and remain accessible at all times.
- The capacity rating plate, the decal information, the hazard warnings and the operating instructions must be checked to ensure that they are consistent with the modifications and must be amended if required.
- Modifications must be designed, checked and implemented by a design office that specialises in industrial trucks. The design office must comply with the standards and directives valid at the time that modifications are made.

Decal information with the following data must be permanently affixed to the truck so that it is clearly visible:

- Type of modification
- Date of modification
- Name and address of the company that carried out the modification

Basic principles for safe operation

Changes to the overhead guard and roof loads

⚠ DANGER

In the event of the overhead guard failing due to a falling load or the truck tipping over, there are potentially fatal consequences for the driver. There is a risk to life!

Welding and drilling on the overhead guard changes the material characteristics and the structural design of the overhead guard. Excessive forces caused by falling loads or the truck tipping over may result in buckling of the modified overhead guard and no protection for the driver.

- Do not perform welding on the overhead guard.
- Do not perform drilling on the overhead guard.

⚠ CAUTION

Heavy roof loads damage the overhead guard!

To ensure the stability of the overhead guard at all times, a roof load may only be mounted on the overhead guard if the structural design has been tested and the manufacturer has given approval.

- Seek advice from the authorised service centre for the mounting of roof loads.

Warning regarding non-original parts

Original parts, attachments and accessories are specially designed for this truck. We specifically draw your attention to the fact that parts, attachments and accessories supplied by other companies have not been tested and approved by STILL.

⚠ CAUTION

Installation and/or use of such products may therefore have a negative impact on the design features of the truck and thus impair active and/or passive driving safety.

We recommend that you obtain approval from the manufacturer and, if necessary, from the relevant regulatory authorities before installing such parts. The manufacturer accepts no liability for any damage caused by the use of non-original parts and accessories without approval.

Damage, defects and misuse of safety systems

Damage or other defects on the truck or attachment must be reported to the supervisor or responsible fleet manager immediately so that they can have the defect rectified.

Trucks and attachments that are not functional or safe to drive may not be used until they have been properly repaired.

Do not remove or deactivate safety systems and switches.

Fixed set values may only be changed with the approval of the manufacturer.

Work on the electrical system (e.g. connecting a radio, additional headlights etc.) is only permitted with the manufacturer's written approval. All electrical system interventions must be documented.

Even if they are removable, roof panels may not be removed, as they are designed to protect against small falling objects.

Tyres

DANGER

Risk to stability!

Failure to observe the following information and instructions can lead to a loss of stability. The truck may tip over, risk of accident!

The following factors can lead to a loss of stability and are therefore **prohibited**:

- Different tyres on the same axle, e.g. pneumatic tyres and superelastic tyres
- Tyres not approved by the manufacturer
- Excessive tyre wear
- Tyres of inferior quality
- Changing rim wheel parts
- Combining rim wheel parts from different manufacturers



Basic principles for safe operation

The following rules must be observed to ensure stability:

- Only use tyres with equal and permitted levels of wear on the same axle
- Only use wheels and tyres of the same type on the same axle, e.g. only superelastic tyres
- Only use wheels and tyres approved by the manufacturer
- Only use high-quality products

Wheels and tyres approved by the manufacturer can be found on the spare parts list. If other wheels or tyres are to be used, authorisation from the manufacturer must be obtained beforehand.

- Contact the authorised service centre on this matter.

When changing wheels or tyres, always ensure that this does not cause the truck to tilt to one side (e.g. always replace right-hand and left-hand wheels at the same time). Changes must only be made following consultation with the manufacturer.

If the type of tyre used on an axle is changed, for example from superelastic tyres to pneumatic tyres, the load diagram must be changed accordingly.

- Contact the authorised service centre on this matter.

Medical equipment

WARNING

Electromagnetic interference may occur on medical devices!

Only use equipment that is sufficiently protected against electromagnetic interference.

Medical equipment, such as pacemakers or hearing aids, may not work properly when the truck is in operation.

- Ask your doctor or the manufacturer of the medical equipment to confirm that the medical equipment is sufficiently protected against electromagnetic interference.

Exercise caution when handling gas springs and accumulators

⚠ WARNING

Gas springs are under high pressure. Improper removal results in an elevated risk of injury.

For ease of operation, various functions on the truck can be supported by gas springs. Gas springs are complex components that are subject to high internal pressures (up to 300 bar). They may under no circumstances be opened unless instructed to do so, and may be installed only when not under pressure. If required, the authorised service centre will depressurise the gas spring in accordance with the regulations before removal. Gas springs must be depressurised before recycling.

- Avoid damage, lateral forces, buckling, temperatures over 80°C and heavy contamination.
- Damaged or defective gas springs must be changed immediately.
- Contact the authorised service centre.

⚠ WARNING

Accumulators are under high pressure. Improper installation of an accumulator results in an elevated risk of injury.

Before starting work on the accumulator it must be depressurised.

- Contact the authorised service centre.

Length of the fork arms

⚠ DANGER

Risk of accident due to the incorrect selection of fork arms!

- The fork arms must match the depth of the load.

If the fork arms are too short, the load may fall off the arms after it has been picked up. In addition, be aware that the load centre of gravity may shift as a result of dynamic forces, such as braking. A load that is otherwise resting safely on the fork arms may move forwards and fall.

If the fork arms are too long, they can catch on loading units behind the load that is to be



Basic principles for safe operation

picked up. These other loading units then fall over when the load is raised.

- For help with selecting the correct fork arms, contact the authorised service centre.



Residual risk

Residual dangers, residual risks

Despite careful working and compliance with standards and regulations, the occurrence of other risks when using the truck cannot be entirely excluded.

The truck and all other system components comply with current safety requirements. Nevertheless, even when the truck is used for its proper purpose and all instructions are followed, some residual risk cannot be excluded.

Even beyond the narrow danger areas of the truck itself, a residual risk cannot be excluded. Persons in this area around the truck must exercise a heightened degree of awareness, so that they can react immediately in the event of any malfunction, incident or breakdown etc.

⚠ WARNING

All persons that are in the vicinity of the truck must be instructed regarding these risks that arise through use of the truck.

In addition, we draw attention to the safety regulations in these operating instructions.

Risks can include:

- Escape of consumables due to leakages, rupture of lines and containers etc.
- Risk of accident when driving over difficult ground such as gradients, smooth or irregular surfaces, or with poor visibility etc.
- Falling, tripping etc. when moving on the truck, especially in wet weather, with leaking consumables or on icy surfaces
- Fire and explosion risks due to batteries and electrical voltages
- Human error resulting from failure to observe the safety regulations,
- Unrepaired damage or defective and worn components,
- Insufficient maintenance and testing
- Use of incorrect consumables
- Exceeding test intervals



Residual risk

The manufacturer is not held responsible for accidents involving the truck caused by the failure of the operating company to comply with these regulations either intentionally or carelessly.

Stability

The stability of the truck has been tested to the latest technological standards and is guaranteed provided that the truck is used properly and according to its intended purpose. These standards only take into account the dynamic and static tipping forces that can arise during specified use in accordance with the operating rules and intended purpose. However, the danger of exceeding the moment of tilt due to improper use or incorrect operation and losing stability can never be excluded.

The loss of stability can be avoided or minimised by the following actions:

- Always secure the load against slipping, e.g. by lashing.
- Always transport unstable loads in suitable containers.
- Always drive slowly when cornering.
- Drive with the load lowered.
- Even with sideshifts, align the load as centrally as possible with the truck and transport in this position.
- Avoid turning and diagonally driving across slopes or gradients.
- Never have the load facing downhill when travelling on slopes or gradients.
- Pick up only loads of the approved width.
- Always take great care when transporting suspended loads.
- Do not drive over ramp edges or steps.

Special risks associated with using the truck and attachments

Approval from the manufacturer and attachment manufacturer must be obtained each



Safety

2

Residual risk

time the truck is used in a manner that falls outside the scope of normal use, and in cases where the driver is not certain that he can use the truck correctly and without the risk of accidents.



Residual risk

Overview of hazards and counter-measures

i NOTE

This table is intended to help evaluate the hazards in your facility and applies to all drive types. It does not claim to be complete.

- Observe the national regulations for the country in which the truck is being used.

Hazard	Measure	Check note √ Complete - Not applicable	Notes
Truck equipment does not comply with local regulations	Test	○	If in doubt, consult competent factory inspectorate or employers' liability insurance association
Lack of skills and qualification of driver	Driver training (sit-on and stand-on)	○	BGG 925 VDI 3313 driver permit
Usage by unauthorised persons	Access with key only for authorised persons	○	
Truck not in a safe condition	Recurrent testing and rectification of defects	○	German Ordinance on Industrial Safety and Health (BetrSichV)
Risk of falling when using working platforms	Compliance with national regulations (different national laws)	○	German Ordinance on Industrial Safety and Health (BetrSichV) and employer's liability insurance associations
Impaired visibility due to load	Resource planning	○	German Ordinance on Industrial Safety and Health (BetrSichV)
Contamination of respiratory air	Assessment of diesel exhaust gases	○	Technical Regulations for Hazardous Substances (TRGS) 554 and the German Ordinance on Industrial Safety and Health (BetrSichV)
	Assessment of LPG exhaust gases	○	German threshold limit values list (MAK-Liste) and the German Ordinance on Industrial Safety and Health (BetrSichV)



Safety

2

Residual risk

Hazard	Measure	Check note √ Complete - Not applicable	Notes
Impermissible usage (improper usage)	Issuing of operating instructions	○	German Ordinance on Industrial Safety and Health (BetrSichV) and German Health and labour protection law (ArbSchG)
	Written notice of instruction to driver	○	German Ordinance on Industrial Safety and Health (BetrSichV) and German Health and labour protection law (ArbSchG)
	Note the German Ordinance on Industrial Safety and Health (BetrSichV), the operating instructions and the German Engineering Federation (VDMA) rules	○	
When fuelling			
a) Diesel	Note the German Ordinance on Industrial Safety and Health (BetrSichV), the operating instructions and the German Engineering Federation (VDMA) rules	○	
b) LPG	Note German Social Accident Insurance (DGUV) regulation D34, the operating instructions and the German Engineering Federation (VDMA) rules	○	



2

Safety

Residual risk

Hazard	Measure	Check note √ Complete - Not applicable	Notes
When charging the traction battery	Note the German Ordinance on Industrial Safety and Health (BetrSichV), the operating instructions and the German Engineering Federation (VDMA) rules	○	Association for Electrical, Electronic and Information Technologies (VDE) regulation 0510: In particular - Ensure adequate ventilation - Insulation value within the permissible range
When using battery chargers	Note the German Ordinance on Industrial Safety and Health (BetrSichV), employers' liability insurance association regulation 104 and the operating instructions	○	German Ordinance on Industrial Safety and Health (BetrSichV) and employers' liability insurance association regulation 104
When parking LPG trucks	Note the German Ordinance on Industrial Safety and Health (BetrSichV), employers' liability insurance association regulation 104 and the operating instructions	○	German Ordinance on Industrial Safety and Health (BetrSichV) and employers' liability insurance association regulation 104
With driverless transport systems			
Roadway quality inadequate	Clean/clear driveways	○	German Ordinance on Industrial Safety and Health (BetrSichV)
Load carrier incorrect/slipped	Reattach load to pallet	○	German Ordinance on Industrial Safety and Health (BetrSichV)
Drive behaviour unpredictable	Employee training	○	German Ordinance on Industrial Safety and Health (BetrSichV)
Driveways blocked	Mark driveways Keep driveways clear	○	German Ordinance on Industrial Safety and Health (BetrSichV)
Driveways intersect	Announce right-of-way rule	○	German Ordinance on Industrial Safety and Health (BetrSichV)
No person detection during depositing and retrieval	Employee training	○	German Ordinance on Industrial Safety and Health (BetrSichV)

Danger to employees

According to the German Ordinance on Industrial Safety and Health (BetrSichV) and labour protection law (ArbSchG), the operating company must determine and assess hazards during operation, and establish the labour protection measures required for employees (BetrSichVO). The operating company must therefore draw up appropriate operating instructions (§ 6 ArbSchG) and make them available to the driver. A responsible person must be appointed.

NOTE

Please observe the definition of the following responsible persons: "operating company" and "driver".

The construction and equipment of the truck correspond to the Machinery Directive 2006/42/EC and are therefore marked with CE labelling. These elements are therefore not included in the hazard assessment. Attachments possess their own CE labelling and likewise are not included for that reason. The operating company must, however, select the type and equipment of the trucks so as to comply with the local provisions for deployment.

The result must be documented (§ 6 ArbSchG). In the case of truck applications involving similar hazard situations, the results may be summarised. This overview (see chapter "Overview of hazards and countermeasures") provides help on complying with this regulation. The overview specifies the main hazards that are the most frequent cause of accidents in the event of non-compliance. If other major operational hazards are involved, they must also be taken into consideration.

The conditions of use for trucks are broadly similar in many plants, so the hazards can be summarised in one overview. Observe the information provided by the relevant employers' liability insurance association on this subject.

Safety tests

Safety tests

Regular safety inspection of the truck ▷

Safety inspection based on time and extraordinary incidents

The operating company must ensure that the truck is checked by a specialist at least once a year or after particular incidents.

As part of this inspection, a complete check of the technical condition of the truck must be performed with regard to accident safety. In addition, the truck must be thoroughly checked for damage that could potentially have been caused by improper use. A test log must be created. The results from the inspection must be retained until a further two inspections have been carried out.

The inspection date is indicated by an adhesive label on the truck.

- Arrange for the service centre to perform periodic safety inspections on the truck.
- Observe guidelines for checks carried out on the truck in accordance with FEM 4.004.

The operator is responsible for ensuring any defects are remedied without delay.

- Contact your service centre.

NOTE

Observe the national regulations for your country!

Insulation testing

The insulation of the truck must have sufficient insulation resistance. For this reason, insulation testing in accordance with DIN EN 1175 and DIN 43539, VDE 0117 and VDE 0510 must be conducted at least once yearly as part of the FEM testing.

The insulation testing results must be at least the test values given in the following two tables.

- For insulation testing, contact the authorised service centre.



The exact procedure for this insulation testing is described in the workshop manual for this truck.

i NOTE

The truck's electrical system and drive batteries must be checked separately.

Test values for the drive battery

Component	Recommended test voltage	Measurements		Nominal voltage U_{Batt}	Test values
Battery	50 VDC	Batt+ Batt-	Battery tray	24 volts	> 1200 Ω
	100 VDC			48 volts	> 2400 Ω
	100 VDC			80 volts	> 4000 Ω

Test values for the entire truck

Nominal voltage	Test voltage	Test values for new trucks	Minimum values over the duration of the service life
24 volts	50 VDC	Min. 50 k Ω	> 24 k Ω
48 volts	100 VDC	Min. 100 k Ω	> 48 k Ω
80 volts	100 VDC	Min. 200 k Ω	> 80 k Ω

Safety regulations for handling consumables

Safety regulations for handling consumables

Permissible consumables

DANGER

Failure to observe the safety regulations relating to consumables may result in a risk of injury, death or damage to the environment.

- Observe the safety regulations when handling such materials.

Refer to the maintenance data table for the permissible substances that are necessary for operation (see ⇒ Chapter "Maintenance data table", P. 5-387).

Oils



DANGER

Oils are flammable!

- Follow the statutory regulations.
- Do not allow oils to come into contact with hot engine parts.
- No smoking, fires or naked flames!



DANGER

Oils are toxic!

- Avoid contact and consumption.
- If vapour or fumes are inhaled, move to fresh air immediately.
- In the event of contact with the eyes, rinse thoroughly (for at least 10 minutes) with water and then consult an eye specialist.
- If swallowed, do not induce vomiting. Seek immediate medical attention.



⚠ WARNING

Prolonged intensive contact with the skin can result in dryness and irritate the skin!

- Avoid contact and consumption.
- Wear protective gloves.
- After any contact, wash the skin with soap and water, and then apply a skin care product.
- Immediately change soaked clothing and shoes.

⚠ WARNING

There is a risk of slipping on spilled oil, particularly when combined with water!

- Spilt oil should be removed immediately with oil-binding agents and disposed of according to the regulations.



ENVIRONMENT NOTE

Oil is a water-polluting substance!

- *Always store oil in containers that comply with the applicable regulations.*
- *Avoid spilling oils.*
- *Spilt oil should be removed immediately with oil-binding agents and disposed of according to the regulations.*
- *Dispose of old oils according to the regulations.*

Hydraulic fluid



⚠ WARNING

These fluids are pressurised during operation of the truck and are hazardous to your health.

- Do not spill the fluids.
- Follow the statutory regulations.
- Do not allow the fluids to come into contact with hot engine parts.

Safety regulations for handling consumables



⚠ WARNING

These fluids are pressurised during operation of the truck and are hazardous to your health.

- Do not allow the fluids to come into contact with the skin.
- Avoid inhaling spray.
- Penetration of pressurised fluids into the skin is particularly dangerous if these fluids escape at high pressure due to leaks in the hydraulic system. In case of such injury, immediate medical assistance is required.
- To avoid injury, use appropriate personal protective equipment (e.g. protective gloves, industrial goggles, skin protection and skin care products).



ENVIRONMENT NOTE

Hydraulic fluid is a water-polluting substance.

- *Always store hydraulic fluid in containers that comply with regulations*
- *Avoid spills*
- *Spilt hydraulic fluid should be removed immediately with oil-binding agents and disposed of according to the regulations*
- *Dispose of old hydraulic fluid according to the regulations*

Battery acid



⚠ WARNING

Battery acid contains dissolved sulphuric acid. This is toxic.

- Avoid touching or swallowing the battery acid at all costs.
- In case of injury, seek medical advice immediately.



⚠ WARNING

Battery acid contains dissolved sulphuric acid. This is corrosive.

- When working with battery acid, use appropriate PSA (rubber gloves, apron, protection goggles).
- When working with battery acid, never wear a watch or jewellery.
- Do not allow any acid to get onto clothing or skin or into the eyes. If this does happen, rinse immediately with plenty of clean water.
- In case of injury, seek medical advice immediately.
- Immediately rinse away spilt battery acid with plenty of water.
- Follow the statutory regulations.



ENVIRONMENT NOTE

- Dispose of used battery acid in line with the applicable regulations.

Disposal of consumables



ENVIRONMENT NOTE

Materials that accumulate during repair, maintenance and cleaning must be collected properly and disposed of in accordance with the national regulations for the country in which the truck is being used. Work must only be carried out in areas designated for that purpose. Care must be taken to minimise any environmental pollution.

- Soak up any spilt fluids such as hydraulic oil or gearbox oil immediately using an oil-binding agent.
- Neutralise any spilt battery acid immediately.
- Always observe national regulations concerning the disposal of used oil.



Emissions

Emissions

The values specified apply to a standard truck (compare the specifications in the "Technical data" chapter). Different tyres, lift masts, additional units etc. may produce different values.

Noise emissions

The values were determined based on measuring procedures from the standard EN 12053 "Safety of industrial trucks. Test methods for measuring noise emissions", based on EN 12001 and EN ISO 3744 and the requirements of EN ISO 4871.

This machine emits the following sound pressure level:

Continuous sound pressure level in the driver's compartment

L _{pAZ}	Measurement uncertainty K _{pA}
< 70.0 dB(A)	4 dB(A)

The values were determined in the test cycle on an identical machine from the weighted values for operating statuses and idling.

Time proportions:

- Lifting 18%
- Idling 58%
- Driving 24%

However, the indicated noise levels at the truck cannot be used to determine the noise emissions at workplaces according to the most recent version of **Directive 2003/10/EC** (daily personal noise pollution). If required, these noise emissions must be determined directly at the workplaces under the actual conditions present (further sources of noise, particular application conditions, sound reflections) by the operating company.

NOTE

Please observe the definition of the following responsible person: "operating company".



Vibrations

The vibrations of the machine have been determined on an identical machine in accordance with the standards DIN EN 13059 "Safety of industrial trucks - Test methods for measuring vibration" and DIN EN 12096 "Mechanical vibration - Declaration and verification of vibration emission values".

Frequency-weighted effective value of acceleration on the seat

MSG 65 driver's seat	Measurement uncertainty
< 0.7 m/s ²	0.21 m/s ²

Tests have indicated that the amplitude of the hand and arm vibrations on the steering wheel or the operating devices in trucks is less than 2.5 m/s². There are therefore no measurement guidelines for these measurements.

The individual vibration load on the driver over the course of a working day must be determined by the operating company in accordance with **Directive 2002/44/EC** at the actual place of use, to ensure that all additional factors, such as the driving route, intensity of use etc., are considered.

NOTE

Please observe the definition of the following responsible person: "operating company".

2 Emissions Safety

Emissions

Battery



⚠ DANGER

Risk of explosion due to flammable gases!

During charging, the lead-acid battery releases a mixture of oxygen and hydrogen (oxyhydrogen gas). This gas mixture is explosive and must not be ignited.

- Make sure that there is always sufficient ventilation in working areas that are entirely or partially enclosed.
- Keep away from open flames and flying sparks.
- Do not smoke.
- Observe the instructions in the chapter entitled Safety regulations when handling the battery.

Radiation

According to the guidelines DIN EN 62471:2009-03 (VDE 0837-471:2009-03), the STILL Safety-Light (variant) is assigned to risk group 2 due to its photobiological hazard potential.



3

Overviews

3 Overviews

General view

General view

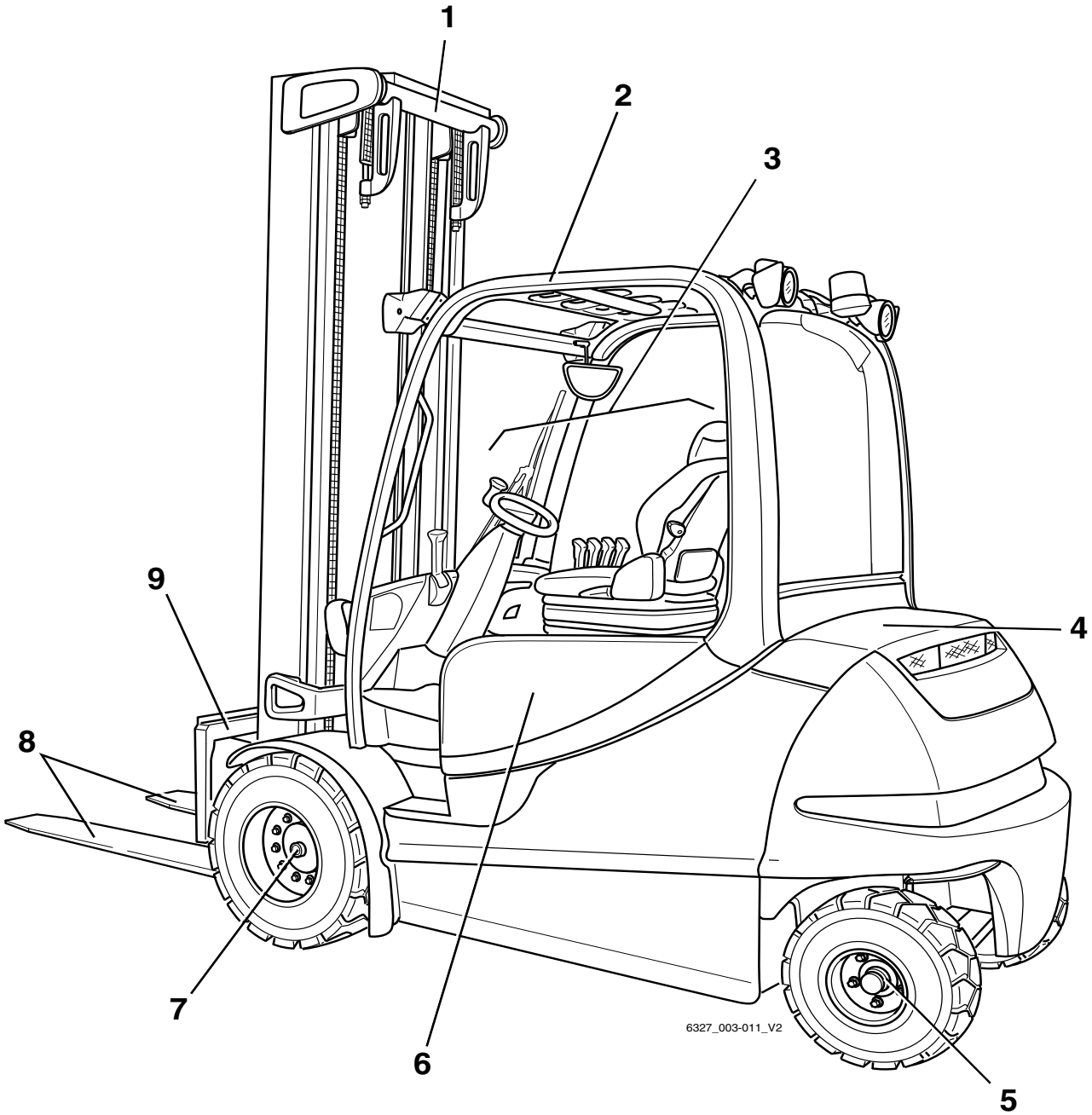

- | | | | |
|---|----------------------|---|--------------------------------|
| 1 | Lift mast | 6 | Battery |
| 2 | Overhead guard | 7 | Drive axle with traction motor |
| 3 | Driver's compartment | 8 | Fork arms |
| 4 | Traction electronics | 9 | Fork carriage |
| 5 | Steering axle | | |



3 Overviews

General view of driver's compartment

General view of driver's compartment

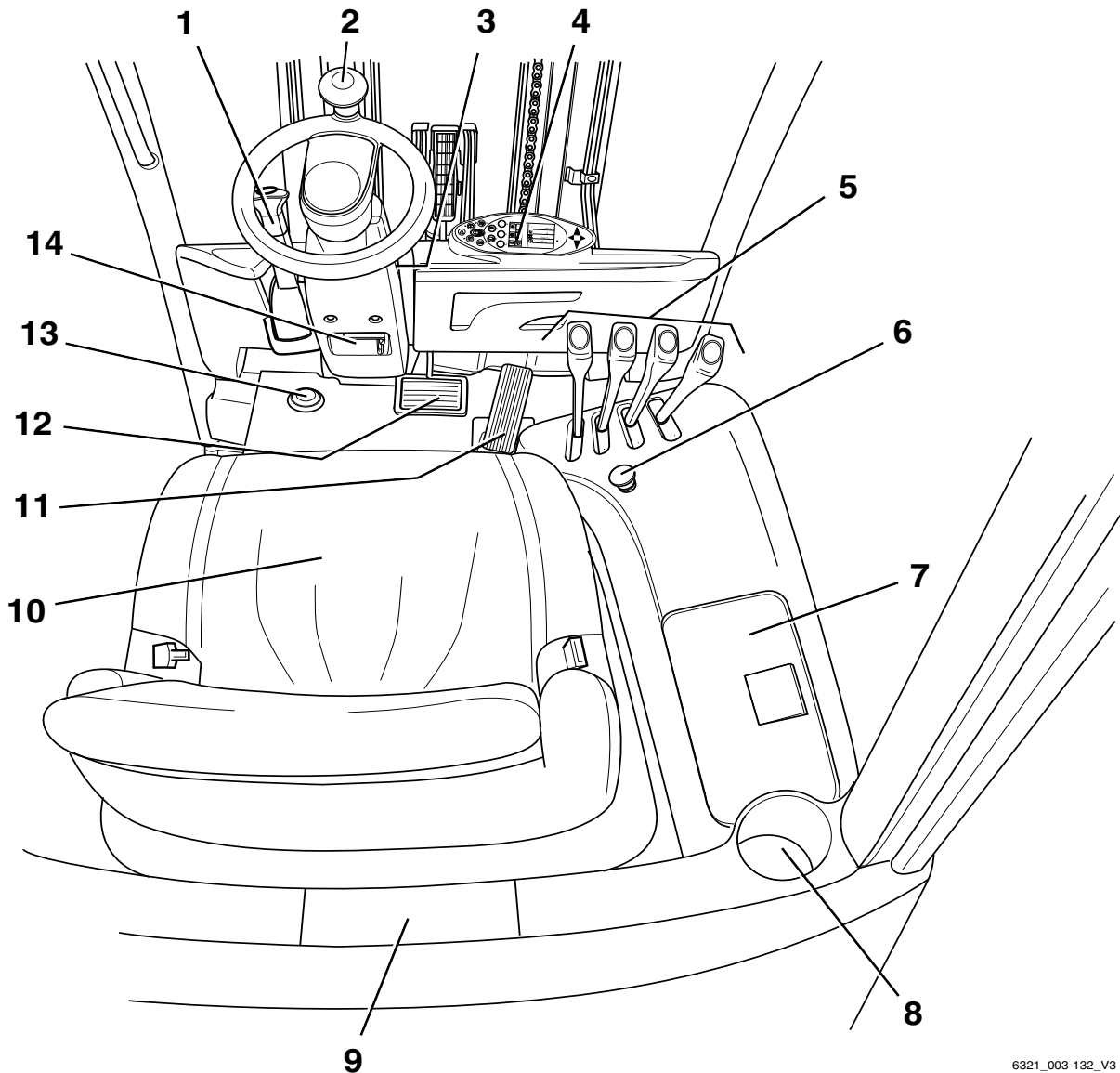

6321_003-132_V3

- | | | | |
|---|---|----|---|
| 1 | Parking brake lever | 8 | Cup holder for max. 1-l bottles |
| 2 | Steering wheel | 9 | Compartment and storage location for operating instructions |
| 3 | Key switch | 10 | Driver's seat |
| 4 | Display operating unit | 11 | Accelerator pedal |
| 5 | Operating devices for hydraulic and traction functions | 12 | Brake pedal |
| 6 | Emergency off switch (only in this position in multi-lever operation) | 13 | Alarm horn foot switch |
| 7 | Storage compartment | 14 | Steering column adjustment lever |

i NOTE

The truck equipment may differ from the equipment shown.

Shelves and cup holders

⚠ WARNING

Objects may fall into the footwell and obstruct the pedals, which poses a risk of accident!

Objects to be stored must be of the correct size so that they cannot fall from the shelf (1) or out of the cup holder (2). Objects that fall into the footwell during travel as a result of steering or braking may slip between the pedals (3) and prevent them from working correctly. It may then not be possible to brake the truck when necessary.

- Bottles of 1 l or smaller may be stored in the cup holder.
- Make sure that stored objects cannot fall from the shelves when the truck is started up, steered or braked.

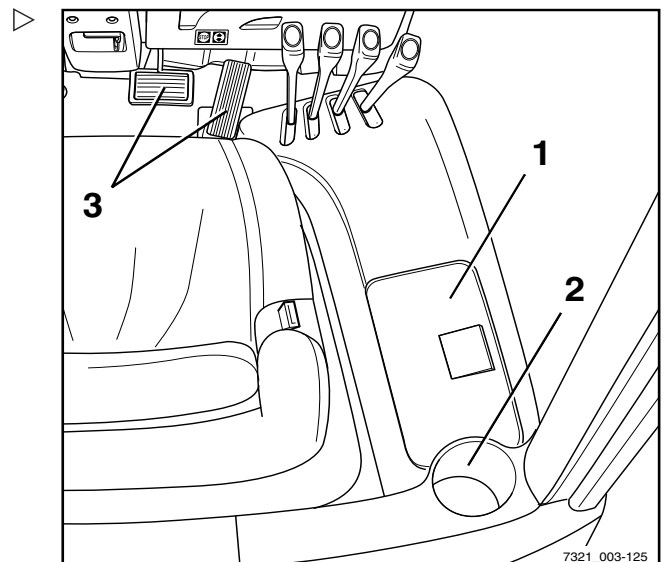

Operating devices and display elements

Operating devices and display elements

Display operating unit

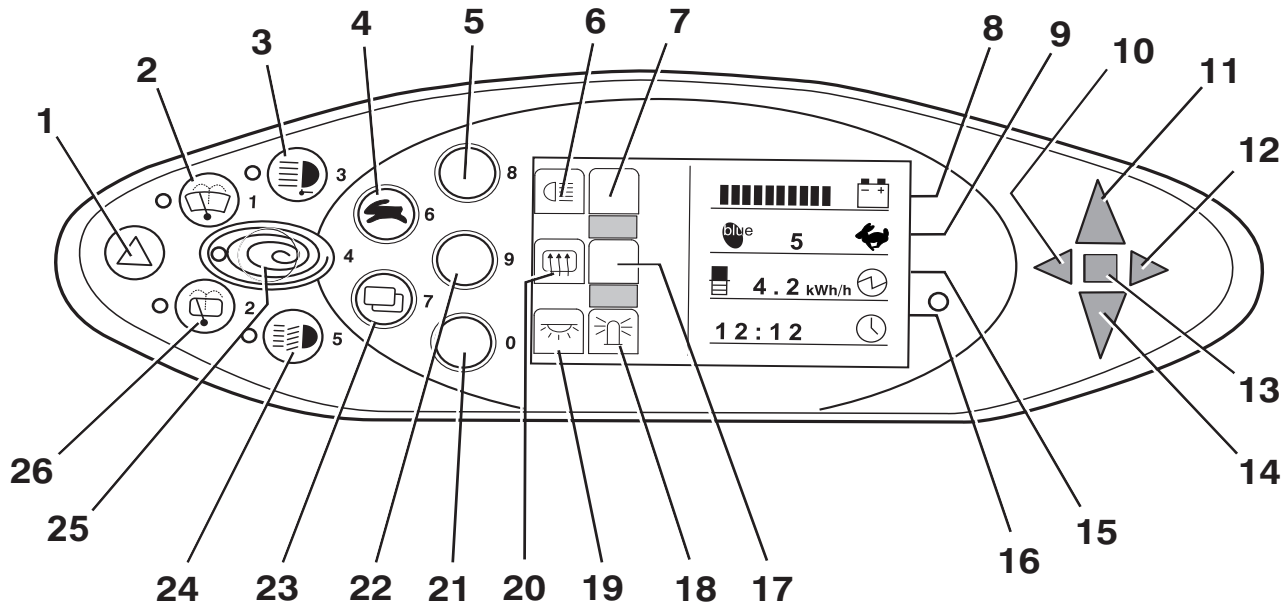

- | | | | |
|----|-------------------------------------|----|--|
| 1 | Hazard warning system button | 14 | Reverse travel display |
| 2 | Front windscreen wiper button | 15 | Power rating display |
| 3 | Working spotlight button | 16 | Time display (digital) |
| 4 | Drive programme selector button | 17 | Not assigned |
| 5 | Softkey for lighting | 18 | Rotating beacon display |
| 6 | Lighting symbol | 19 | Interior light display |
| 7 | Not assigned | 20 | Rear window heating display |
| 8 | Battery charge display | 21 | Softkey for interior light/rotating beacon |
| 9 | Drive programme display (numerical) | 22 | Softkey for rear window heating |
| 10 | Left direction indicator light | 23 | Menu change button |
| 11 | Forward travel display | 24 | Lighting button |
| 12 | Right direction indicator light | 25 | Blue-Q button |
| 13 | Malfunction display | 26 | Rear window wiper button |

i NOTE

The Softkeys (5, 21, 22) and the corresponding indicators (6, 7, 18, 19, 20) are assigned according to the auxiliary equipment installed.

The assignment shown here is an example and may differ from the assignment actually programmed on the truck. Softkeys can be assigned multiple functions that are called up according to the menu navigation. For further information, see the section entitled "Operating the display-operating unit".

- If you have any questions, please contact your authorised service centre.

Lithium-ion battery display

The lithium-ion battery display is located on the side of the battery tray. In addition to the display-operating unit, the lithium-ion battery display also shows the charging status and information relating to the lithium-ion battery.

- Note the information in the separate operating instructions for the lithium-ion battery.

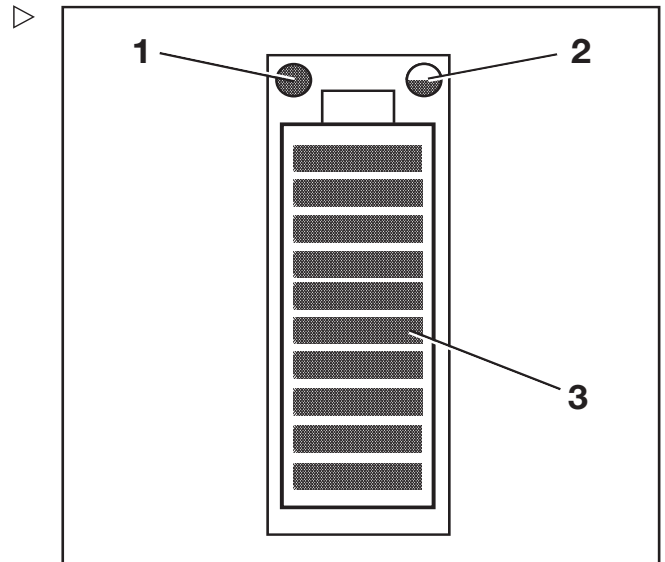

- | | |
|---|-------------------------------|
| 1 | Service LED (red) |
| 2 | Temperature LED (yellow/red) |
| 3 | Charge state LEDs (red/green) |



Operating devices and display elements

Operating devices for hydraulic and traction functions

Different versions of the operating devices are available for operating the truck's hydraulic and traction functions.

The truck can be equipped with the following operating devices:

- **Multiple-lever**
- **Double mini-lever**
- **Triple mini-lever**
- **Quadruple mini-lever**
- **Joystick 4Plus**
- **Fingertip**
- **Mini-console**

Multi-level

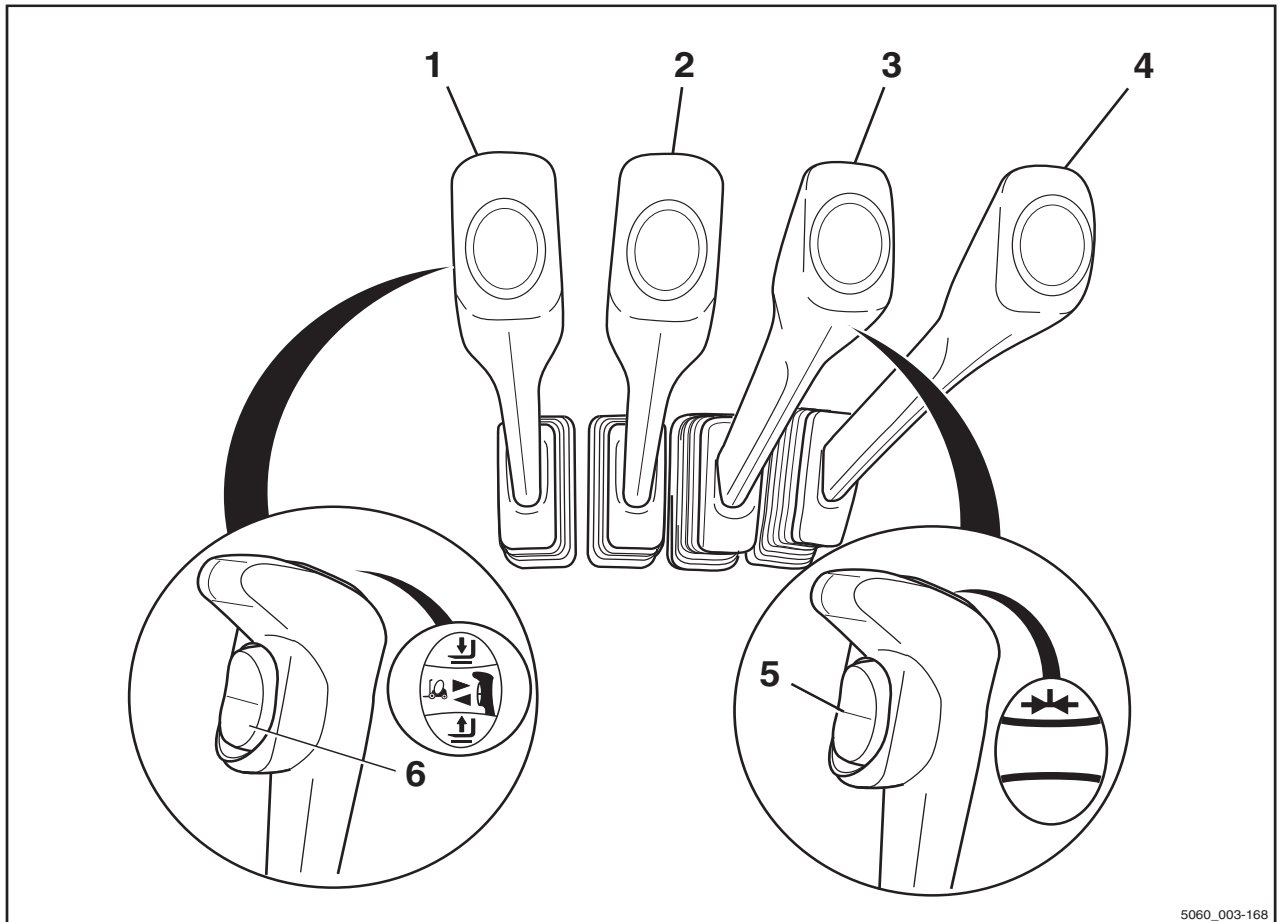

5060_003-168

- 1 "Lift/lower" operating lever
- 2 "Tilt" operating lever
- 3 Operating lever for attachment (variant)
- 4 Operating lever for attachments with 5th function (variant)
- 5 "5th function" function switch (variant)
- 6 Drive direction switch

i NOTE

In the dual-pedal version (variant), the truck is equipped with a signal horn button instead of the drive direction switch.

3 Overviews
Operating devices and display elements

Double mini-lever

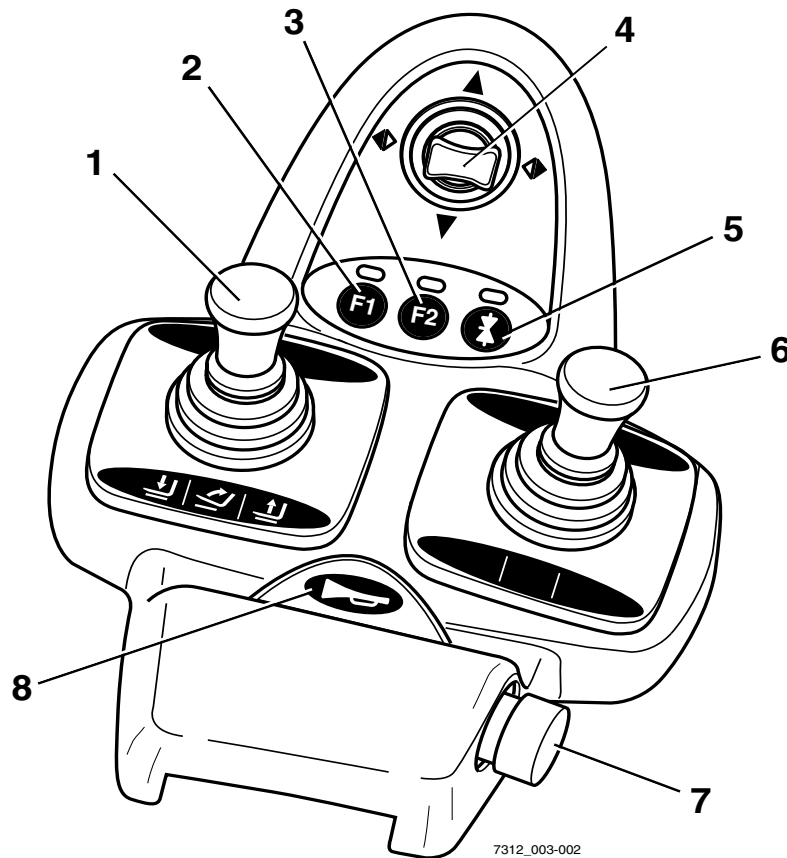

7312_003-002

- | | | | |
|---|--|---|-----------------------------|
| 1 | "Lift mast" 360° lever | 5 | Function key "5th function" |
| 2 | Function key F1 | 6 | "Attachments" cross lever |
| 3 | Function key F2 | 7 | Emergency stop switch |
| 4 | "Drive direction / turn indicator" cross lever | 8 | Signal horn button |

i NOTE

Depending on the specification, various electric attachment parts can be controlled via function keys (2) and (3). Changes must only be made by the authorised service centre.

Three-way mini-lever

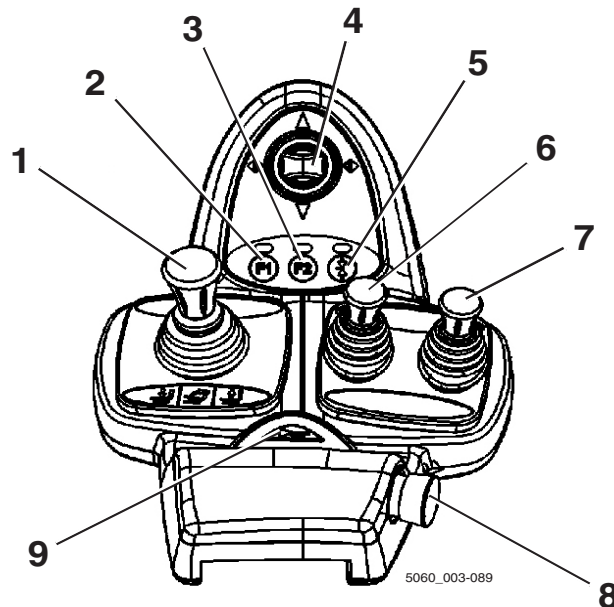

- | | | | |
|---|--|---|--|
| 1 | "Lift mast" 360° lever | 6 | "Auxiliary hydraulics 1" operating lever |
| 2 | Function key F1 | 7 | "Auxiliary hydraulics 2" operating lever |
| 3 | Function key F2 | 8 | Emergency stop switch |
| 4 | "Drive direction / turn indicator" cross lever | 9 | Signal horn button |
| 5 | Function key "5th function" | | |

i NOTE

Depending on the specification, various electric attachment parts can be controlled via function keys (2) and (3). Changes must only be made by the authorised service centre.

3 Overviews
Operating devices and display elements

Four-way mini-lever

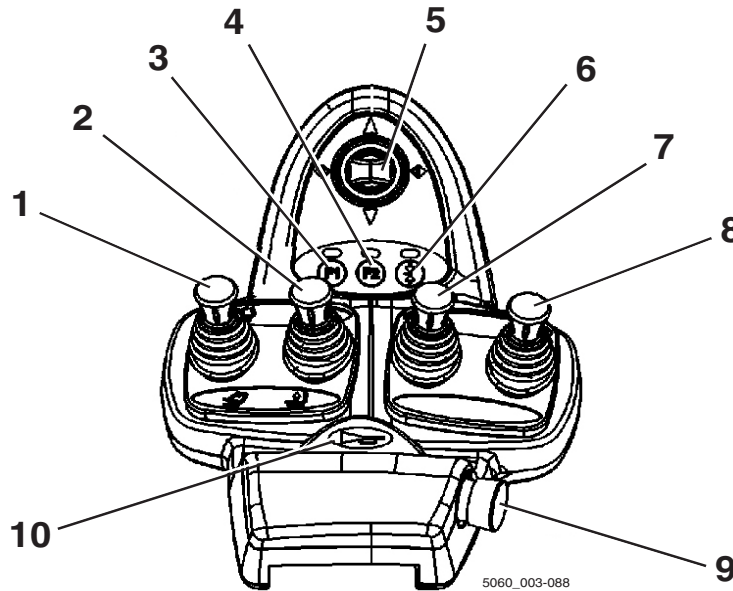

- | | | | |
|---|--|----|--|
| 1 | "Lift/lower" operating lever | 6 | Function key "5th function" |
| 2 | "Tilt" operating lever | 7 | "Auxiliary hydraulics 1" operating lever |
| 3 | Function key F1 | 8 | "Auxiliary hydraulics 2" operating lever |
| 4 | Function key F2 | 9 | Emergency stop switch |
| 5 | "Drive direction / turn indicator" cross lever | 10 | Signal horn button |

i NOTE

Depending on the specification, various electric attachment parts can be controlled via function keys (3) and (4). Changes must only be made by the authorised service centre.

Joystick 4Plus

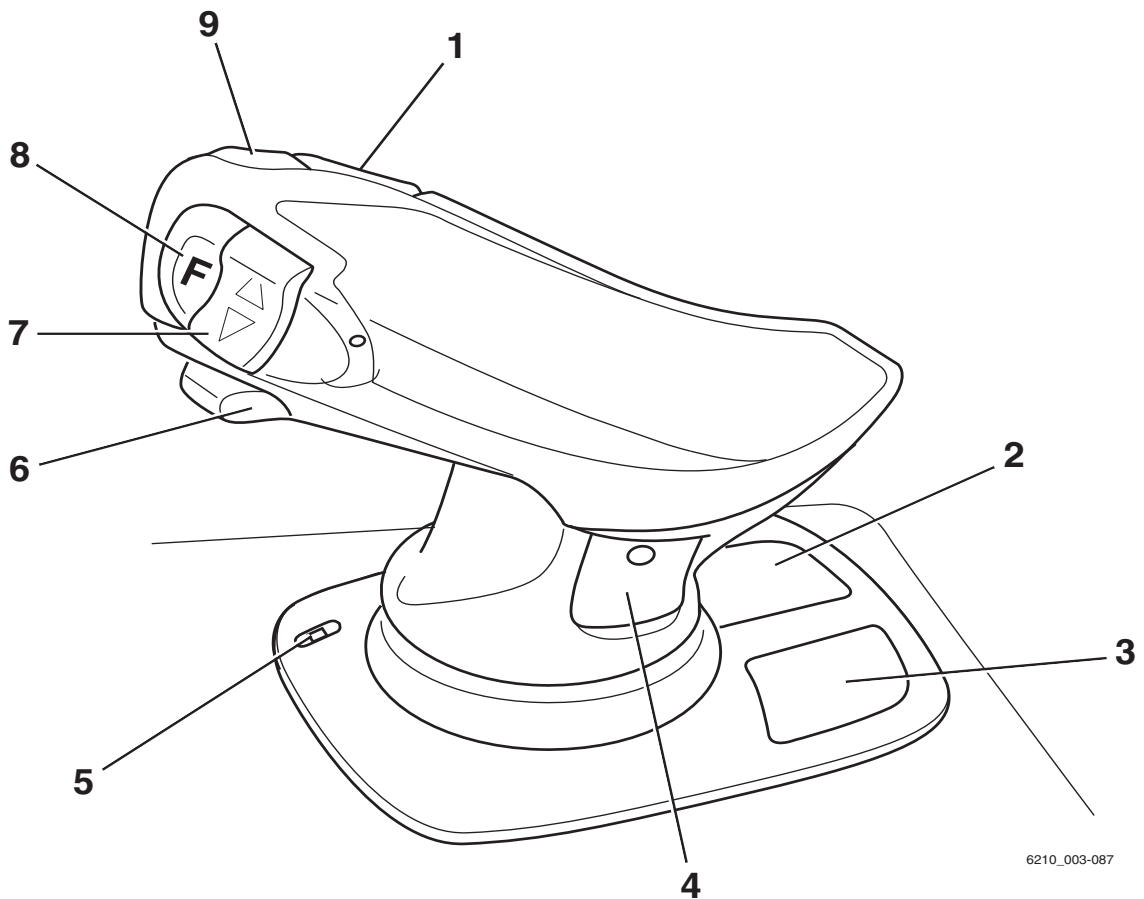

6210_003-087

- | | | | |
|---|---|---|--|
| 1 | Horizontal rocker button for "3rd hydraulic function", tilt the lift mast | 5 | LED for clamp locking mechanism (variant) |
| 2 | Pictograms for the basic hydraulic functions | 6 | Slider for the "4th hydraulic function", e.g. reach frame forwards/backwards |
| 3 | Pictograms for the 5th hydraulic function and the clamp locking mechanism (variant) | 7 | Vertical rocker button for the "drive direction" |
| 4 | Pictograms for the 3rd & 4th hydraulic functions | 8 | Shift key "F" |
| | | 9 | Signal horn button |

3 Operating devices and display elements

Overviews

Fingertip

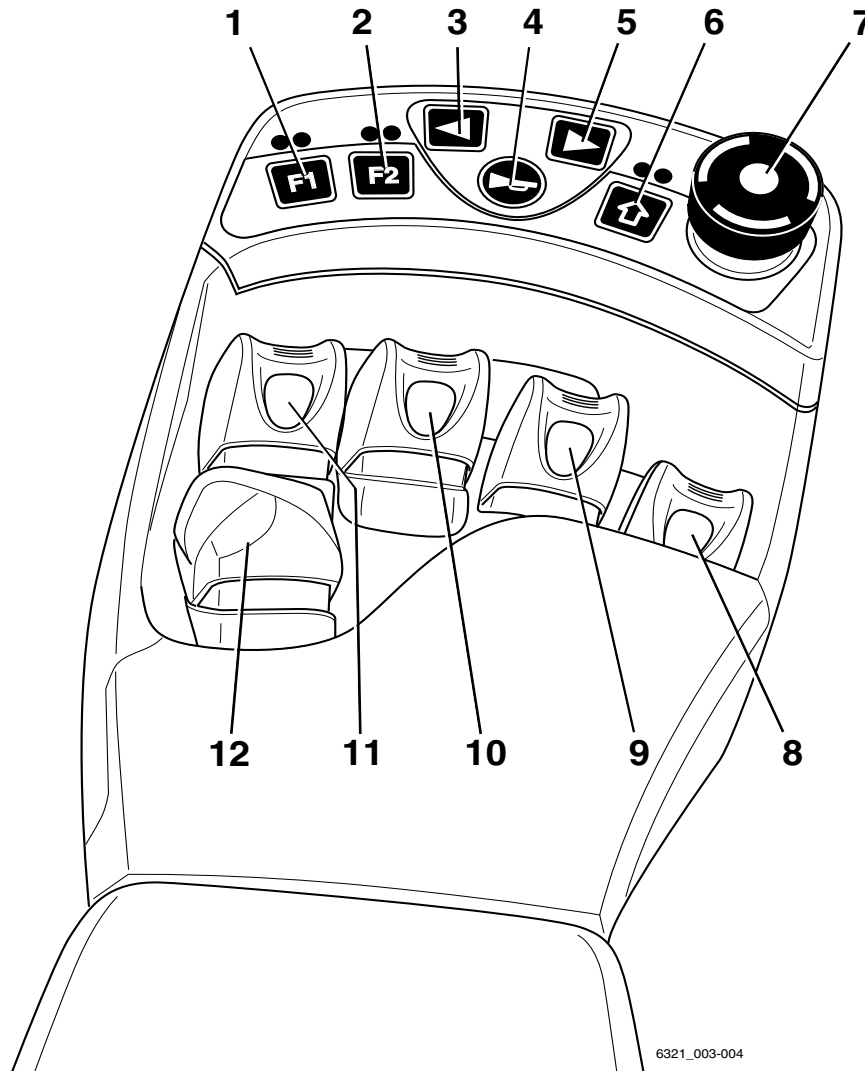

- | | | | |
|---|----------------------------------|----|-------------------------------|
| 1 | Function key F1 | 7 | Emergency stop switch |
| 2 | Function key F2 | 8 | "Attachments" operating lever |
| 3 | Left-hand turn indicator button | 9 | "Attachments" operating lever |
| 4 | Signal horn button | 10 | "Tilt" operating lever |
| 5 | Right-hand turn indicator button | 11 | "Lift/lower" operating lever |
| 6 | Button for 5th function | 12 | Travel direction switch |

i NOTE

Depending on the specification, various electric attachment parts can be controlled via function keys (1) and (2). Changes must only be made by the authorised service centre.

Mini console

The mini console is located on the steering column below the steering wheel.

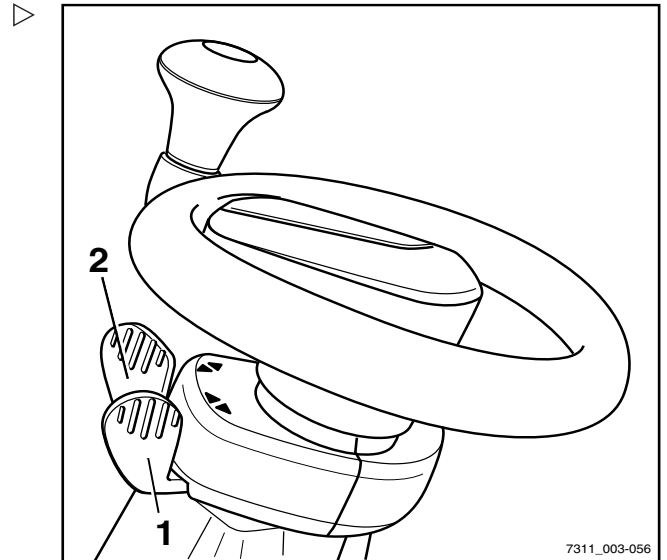

- 1 Travel direction switch
- 2 Direction indicator switch



3

Overviews

Operating devices and display elements



4

Operation

Checks and tasks before daily use

Checks and tasks before daily use

Visual inspections and function checking



⚠ WARNING

Risk of injury from falling off the truck!

When climbing onto the truck, there is a risk of getting stuck or slipping and falling. Use suitable equipment to reach higher points on the truck.

- Use only the steps provided for this purpose to climb onto the truck.
- Use equipment such as stepladders or platforms to reach inaccessible areas.

Damage to the truck or the attachment (variant), non-functional switches or safety systems and modification of predefined set values can lead to unpredictable and dangerous situations. To ensure that the truck is operated safely, the visual inspections and function checking must be carried out before daily use. The components that must be checked and their check points are listed in the following table. If damage or other defects are identified on the truck or the attachment (variant) during the following inspections, the truck must not be used until it has been properly repaired. Damage or other defects must be reported to the supervisor or the responsible fleet manager immediately so that repairs by the authorised service centre can be arranged.

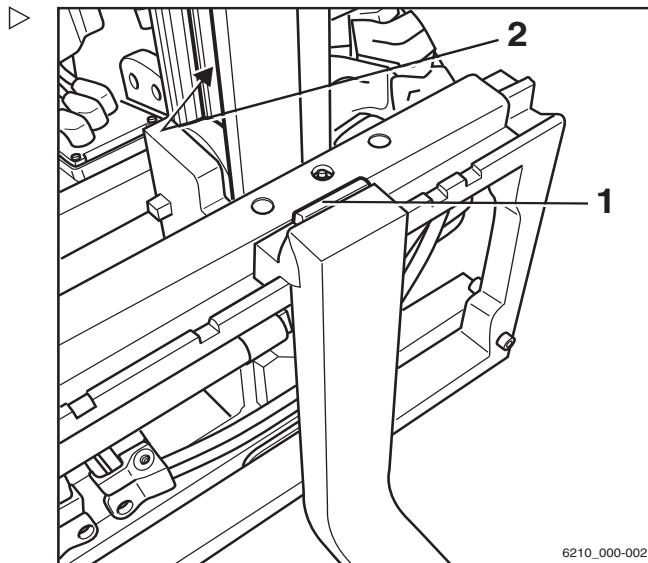

Fork arms and roller tracks

Ensure that the truck is safe for operation each day before it is used:

Component	Course of action
Fork arms, general lifting accessories	Perform a visual inspection to check for deformation and wear (e.g. to check if they are bent, broken or feature significant wear). Check the condition and function of the safety devices (1) to prevent lifting and shifting.
Roller tracks (2)	Make sure that there is a film of grease.
Load chains	Perform a visual inspection to ensure that the chains are intact and have adequate and even tension.



Operation

4

Checks and tasks before daily use

Component	Course of action
Attachments (variant)	Ensure that the attachments are mounted correctly in accordance with the operating instructions from the manufacturer. Perform a visual inspection to ensure that the attachments are intact and are leak-tight. Perform checks to ensure the attachments are working correctly.
Lift cylinders, tilt cylinders, tank, valve block, hoses, pipes, connections	Perform a visual inspection for damage and leak-ages. Have damaged components replaced by the authorised service centre.
Underside	Check the area under the truck for leaking consumables.
Wheels, tyres	Perform a visual inspection for wear and damage. Make sure that only rims of the same type from the same manufacturer are fitted. In the event of uneven tyre wear, replace both tyres. Observe the safety regulations in the section entitled "Tyres".
Axle	Make sure that no consumables are escaping from the axle.
Overhead guard, guard grille (variant)	Perform a visual inspection for integrity. Check for secure mounting.
Steps	Make sure they are clean (free of ice, not slippery).
Panes of glass (variant)	Perform a visual inspection for integrity. Make sure they are clean (also free of ice).
Handholds	Check for secure mounting.
Maintenance lids	Check the close function and close.
Battery hood	Make sure that there are no unused bores in the battery hood.
Battery cover	Perform a visual inspection for integrity and deformation. Check that the interlock is in good condition and is working correctly. Check the close function. Close.
Battery	Check that the interlock is in good condition and is working correctly. Lock the battery.

Checks and tasks before daily use

Component	Course of action
Battery male connector and plug connection	Inspect the battery male connector and the plug connection for moisture or any foreign objects that may have become lodged and remove as necessary, e.g. using compressed air. Perform a visual inspection for integrity and deformation. Check the contacts. Have damaged battery male connectors replaced by the authorised service centre.
Coupling pin, tow coupling (variant)	Perform a visual inspection for deformation and wear (for example: bent, torn, broken). Check the securing bush in the counterweight for integrity and to ensure that it is working correctly. Check that the linchpin is present and working correctly (chain, rope, split pin).
Labelling, adhesive label	Check that labels are present and intact/legible. Replace damaged or missing adhesive labels in accordance with the section entitled "Labelling points".
Driver's seat, seat belt	Check the integrity and function.
Lighting, warning units	Check the integrity and function.
Antistatic belt (3), corona electrode (4) (See the following illustration.)	Perform a visual inspection for integrity. Ensure cleanliness. Make sure that the antistatic belt (3) is still long enough to touch the ground. The discharge wires of the corona electrode (4) must not touch the ground. The wires discharge the energy to the air.

Depending on the tyres used, the truck is fitted with one or more antistatic belts (3) and/or with a corona electrode (4). These components ensure that the truck cannot charge statically. ▷

- Do not use the truck if there is any damage or defects.
- In this case, contact your authorised service centre.

Any other necessary tasks are summarised under their own headings, e.g. adjusting the driver's seat.

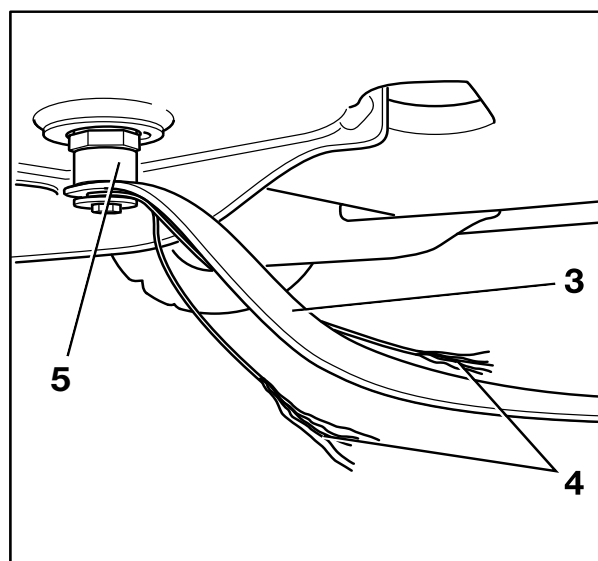

Antistatic belt and corona electrode

Climbing into and out of the truck

⚠ WARNING

Risk of injury when climbing into and out of the truck due to slipping, striking parts of the truck or becoming stuck!

If the footwell cover is very dirty or smeared with oil, there is a risk of slipping. There is a risk of hitting your head on the post of the overhead guard or of your clothes becoming stuck when climbing out of the truck.

- Ensure that the footwell cover is non-slip.
- Do not jump into or out of the truck.
- Ensure that you have a secure grip on the truck.

⚠ WARNING

Risk of injury when jumping out of the truck!

If your clothing or jewellery (e.g. watch, ring etc.) becomes stuck on a component while you are jumping out of the truck, this can lead to serious injuries (e.g. from falling, loss of fingers etc.). It is forbidden to jump out of the truck.

- Do not jump out of the truck.
- Do not wear jewellery at work.
- Do not wear loose-fitting workwear.

⚠ CAUTION

Components may become damaged through incorrect use!

Truck components, such as the driver's seat, steering wheel, parking brake lever etc., are not designed to be used for climbing in and out of the truck and can be damaged due to misuse.

- Only use the fittings specifically designed for the purpose of climbing into and out of the truck.

4 Operation

Checks and tasks before daily use

To assist with climbing into and out of the truck, the footwell must be used as a step (4) and the handle (1) must be used for support. The post of the overhead guard (5) can also be used for support.

Always climb into the truck in a forwards motion:

- Grip the handle (1) with your left hand and hold on.
- Put your left foot on the step (3).
- Enter the truck with your right foot first and sit down on the driver's seat (2).

Always climb out of the truck backwards:

- Grip the handle (1) with your left hand and hold on.
- Stand up from the driver's seat and place your left foot on the step (3).
- Climb out of the truck right foot first.

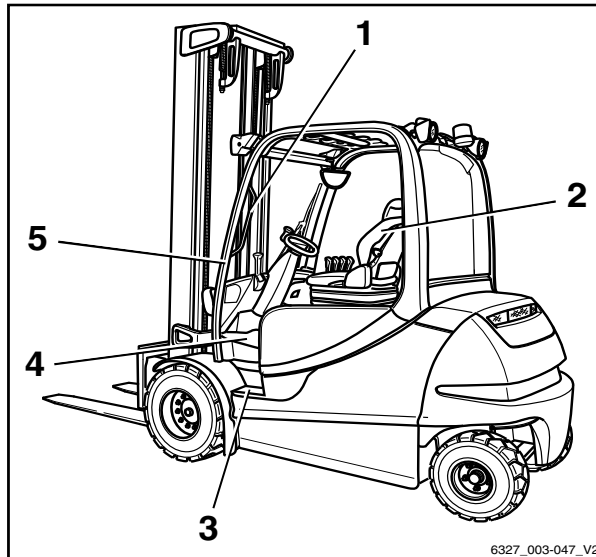

Adjusting the MSG 65/MSG 75 driver's seat

⚠ DANGER

There is a risk of accident if the seat or seat backrest shifts suddenly, which could cause the driver to move in an uncontrolled manner. This may result in unintentional actuation of the steering or operating devices and thus cause the truck or load to move in an uncontrolled fashion.

- Do not adjust the seat or seat backrest while driving
- Adjust the seat and the seat backrest so that all operating devices can be actuated safely
- Ensure that the seat and seat backrest are securely engaged

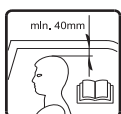

⚠ WARNING

On some equipment variants, the amount of head clearance on the truck may be restricted.

On these specific equipment variants, the distance between the head and the lower edge of the roofing sheet must be at least 40 mm.

Operation

4

Checks and tasks before daily use

NOTE

If there are separate operating instructions for the seat, they must be followed.

WARNING

To obtain optimum seat cushioning, you must adjust the seat suspension to your own body weight. This is better for your back and protects your health.

- To prevent injury, make sure that there are no objects within the swivel area of the seat

Moving the driver's seat

- Lift and hold the lever (1)
- Push the driver's seat into the desired position.
- Release the lever.
- Ensure that the driver's seat is securely engaged.

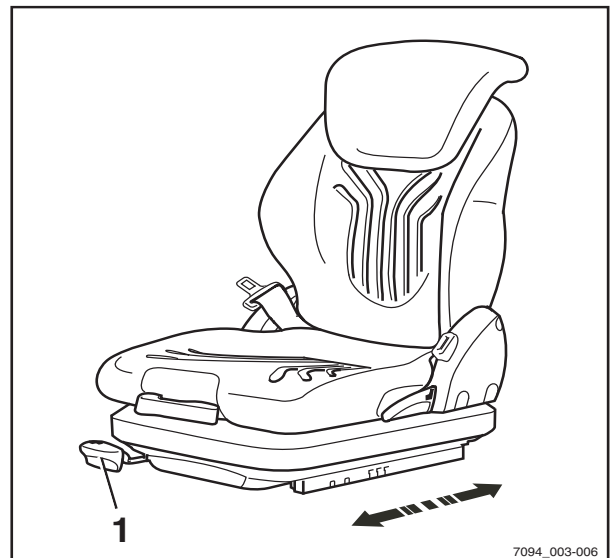

Adjusting the seat backrest

Do not put pressure on the seat backrest while engaging it.

- Lift and hold the lever (2)
- Push the seat backrest into the desired position.
- Release the lever.
- Ensure that the seat backrest is securely engaged.

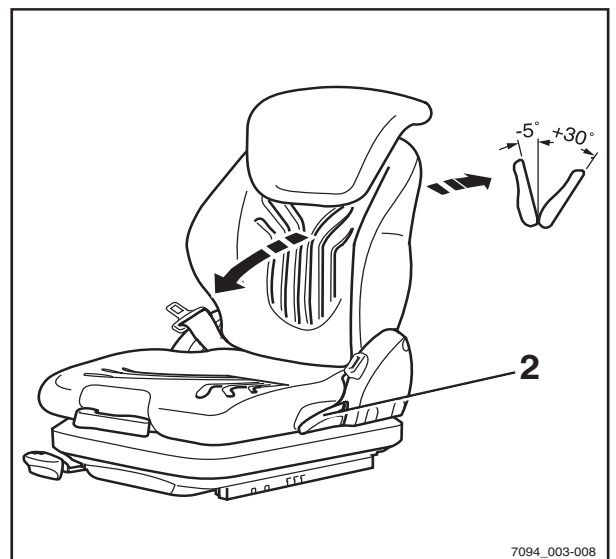

NOTE

The backwards tilt angle of the seat backrest can be restricted by the structural condition of the truck.

Checks and tasks before daily use

Adjusting the seat suspension

i NOTE

The driver's seat can be adjusted to suit the weight of the individual driver. In order to achieve the best seat suspension setting, the driver should perform the adjustment whilst sitting in the seat.

i NOTE

The driver's seat MSG 65/MSG 75 is designed for people weighing between 45 kg and 170 kg.

i NOTE

The MSG 75 seat is equipped with electric air suspension that is activated using an electric switch instead of the lever (3).

- Fully extend the weight-adjusting lever (3)
- Pump it up or down to set the driver's weight.
- Return the weight adjusting lever to the central initial position before each new lift (audible click).
- Fully fold in the weight adjusting lever once adjustment is complete.

i NOTE

The driver's weight has been selected correctly when the arrow (4) is in the centre of the inspection window. If the seat does not move any further when you pump the weight adjusting lever, the minimum or maximum weight setting has been reached.

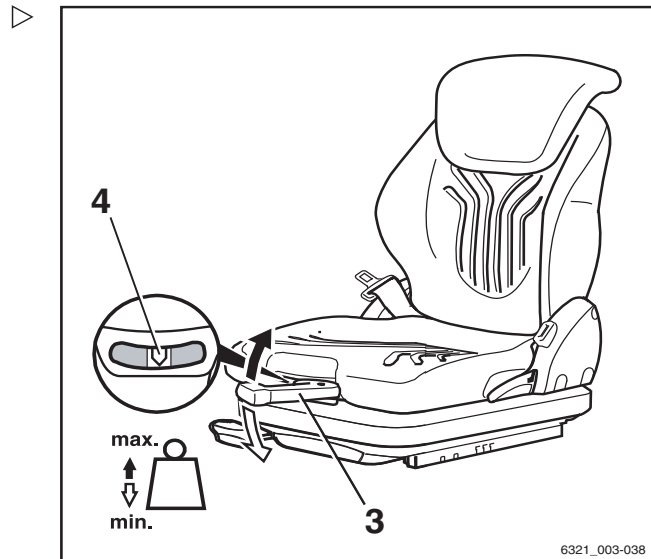

Operation

4

Checks and tasks before daily use

Adjusting the lumbar support (variant) ▷

NOTE

The lumbar support can be adjusted to suit the contours of the individual driver's spine. Adjusting the lumbar support moves a convex support cushion into the upper or lower part of the backrest.

- Turn the turning knob (5) up or down until the lumbar support is in the desired position

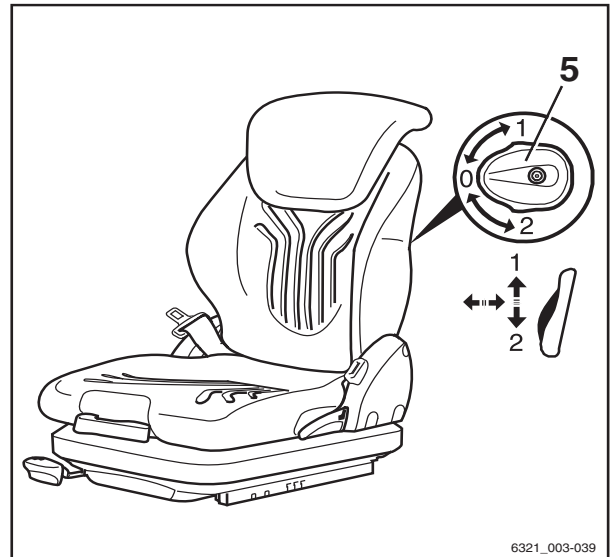

Adjusting the backrest extension (variant) ▷

- Adjust the backrest extension (6) by pulling it out or pushing it into the desired position.

To remove the backrest extension, move it past the end stop by jolting it upwards.

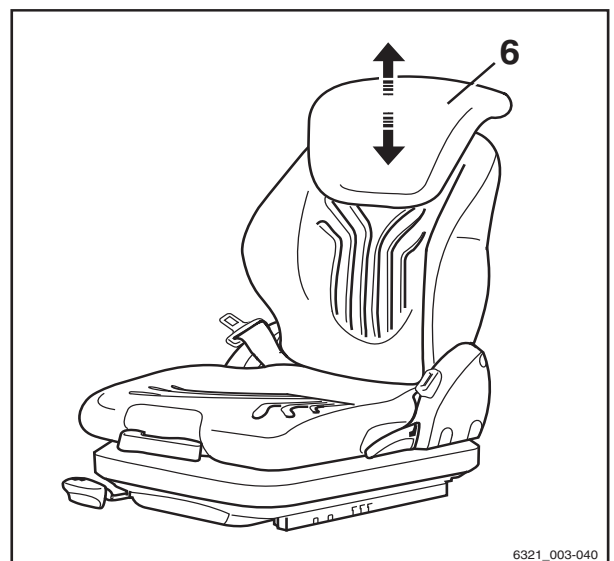

4 Operation

Checks and tasks before daily use

Switching the seat heater (variant) on and off

i NOTE

The seat heater only functions if the seat contact switch is active, i.e. when the driver is sitting on the driver's seat.

- Switch the seat heater (7) on or off using the switch.

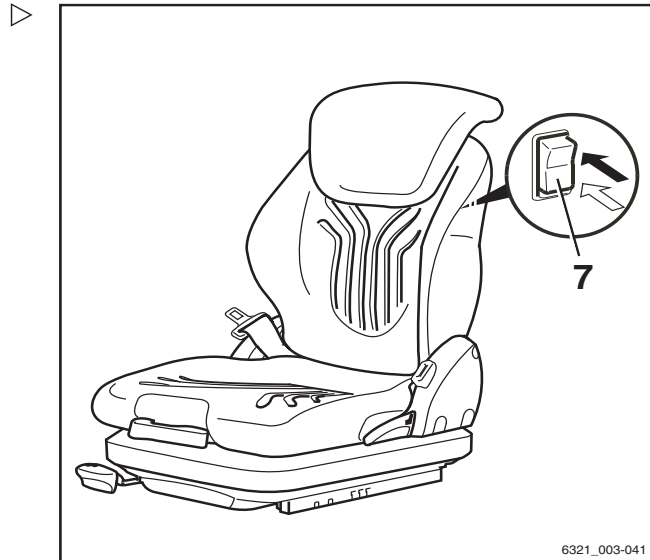

Seat belt



⚠ DANGER

Even when using an approved restraint system, there is some residual risk that the driver might be injured if the truck tips over.

This risk of injury can be reduced through the combined use of the restraint system and the seat belt.

In addition, the seat belt protects against the consequences of rear-end collisions and falling off a ramp.

- We therefore recommend that you also use the seat belt.

⚠ DANGER

Only bracket doors (variant) or the driver's cab (variant) with closed, fixed doors constitute a driver restraint system. Plastic doors (weather protection) do not constitute a restraint system!

If you need to open or remove the doors, you must use an alternative suitable restraint system (e.g. a seat belt).

Fastening the seat belt

⚠ DANGER

Risk to life when driving without a seat belt!

If the truck tips over or crashes into an obstacle and the driver is not wearing the seat belt, the driver may be thrown from the truck. The driver could slide under the truck or collide with an obstacle.

There is a risk of fatal injury!

- Fasten the seat belt before every trip.
- Do not twist the seat belt when fastening it.
- Only use the seat belt to secure one person.
- Have any malfunctions repaired by the authorised service centre.

i NOTE

The buckle has a buckle switch (variant). In the event of an operating error or malfunction, the message SAFETY BELT appears in the display and operating unit, see the chapter entitled "Display messages".

- Pull the seat belt (3) out of the belt retractor without jerking and fasten closely around the body over the thighs.

i NOTE

Sit as far back as possible so that your back is leaning against the seat backrest. The automatic blocking mechanism permits sufficient freedom of movement on the seat.

- Click the belt tongue (2) into buckle (1).
- Check tension of the seat belt. It should be close to the body.

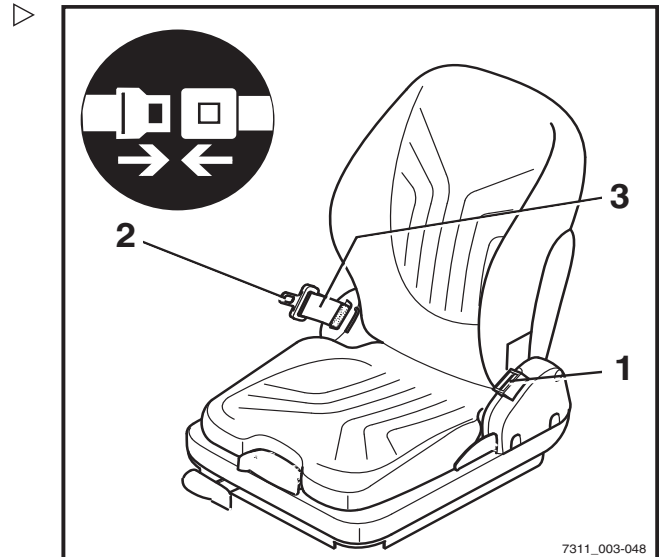

4

Operation

Checks and tasks before daily use

Fastening on a steep slope

The automatic blocking mechanism prevents the belt from being extended whenever the truck is on a steep gradient. It is not possible to pull the seat belt any further out of the belt retractor.

- Move away carefully on the slope.
- Fasten the seat belt.

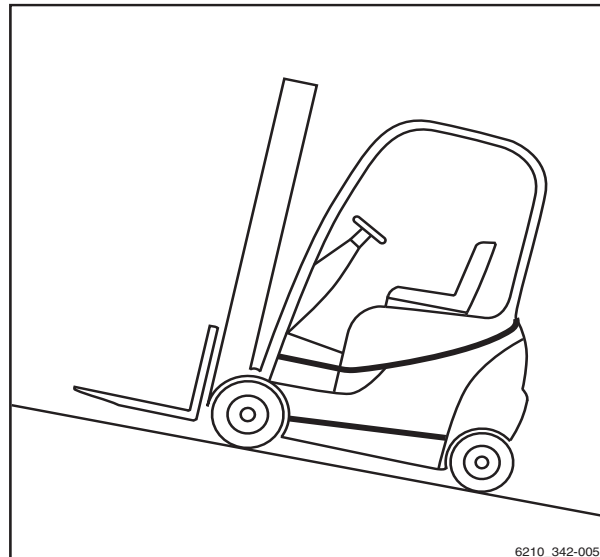

Releasing the seat belt

- Push the red button (4) on the buckle (1).
- Manually guide the belt tongue slowly back to the retractor.

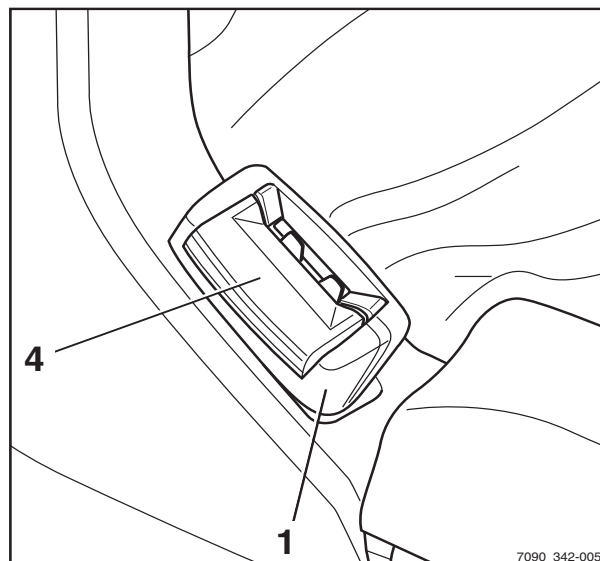

i NOTE

Do not allow the seat belt to retract too quickly. The automatic blocking mechanism may be triggered if the belt tongue strikes the housing. It will then no longer be possible to pull the seat belt out with the usual force.

- Using increased force, pull the seat belt around 10-15 mm out of the retractor to disengage the blocking mechanism.
- Slowly allow the seat belt to retract again.
- Protect the seat belt from dirt (for example, by covering it).

Malfunction due to cold

- If the buckle or belt retractor is frozen, thaw them out and dry them thoroughly to prevent recurrence.

⚠ CAUTION

- The seat belt may be damaged by heat!
Do not subject the buckle or belt retractor to excessive heat when thawing.
- Do not use air warmer than 60°C when thawing.

Adjusting the armrest

⚠ DANGER

There is a risk of accident if the armrest lowers suddenly, causing the driver to move in an uncontrolled manner. This can result in unintentional actuation of the steering or the operating devices and thus cause uncontrolled movements of the truck or load.

- Do not adjust the armrest while driving.
- Adjust the armrest so that all operating devices can be actuated safely.
- Ensure that the armrest is securely tightened.

Adjusting the length of the armrest

- Release the star-grip handle (1) by turning it anti-clockwise.
- Shift the armrest (2) into the desired position.
- Tighten the star-grip handle by turning it clockwise.
- Check that the armrest is firmly attached.

Adjusting the height of the armrest

- Release hand wheel (3) by turning it anti-clockwise.
- Shift the armrest (2) into the desired position.
- Tighten the hand wheel by turning it clockwise.
- Check that the armrest is firmly attached.

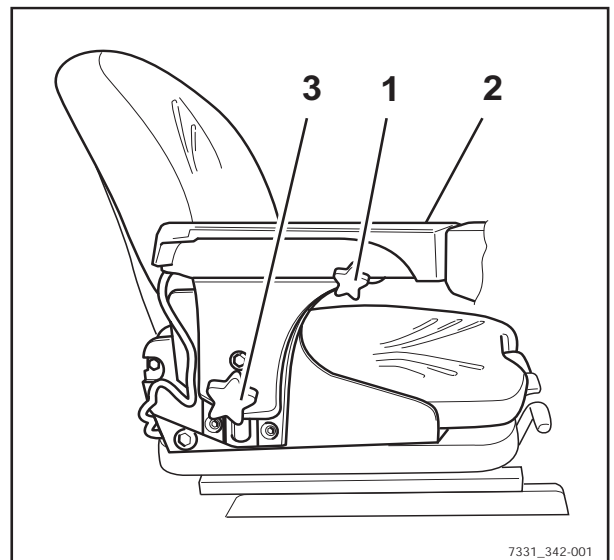

7331_342-001

4 Operation

Checks and tasks before daily use

Adjusting the steering column

⚠ DANGER

Risk of accidents!

Adjusting the steering column during travel may cause the truck to career out of control.

- Adjust the steering column only when the truck is at a standstill.
- Ensure that the steering column is engaged.

- Press down and hold the lever (2) for steering column adjustment.
- Position the steering column (1) and release the lever.

When the steering column engages, the lever snaps back to the initial position.

- Gently push and pull on the steering column to make sure that the steering column is engaged.

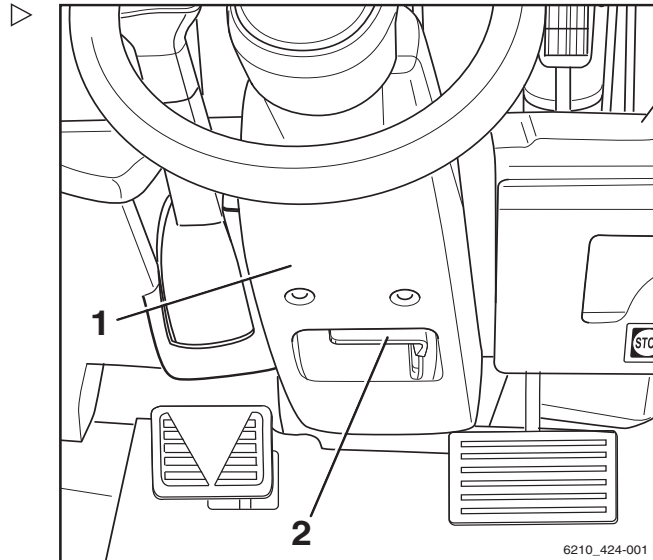

6210_424-001

Unlocking the emergency off switch

- Pull out/turn the emergency off switch (1) until it unlocks. ▷

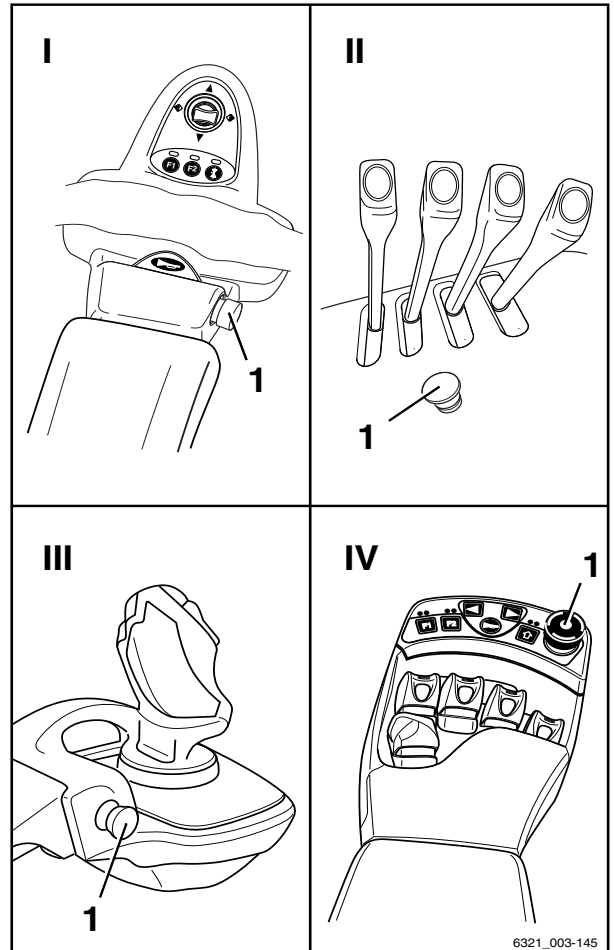

4 Operation

Checks and tasks before daily use

Operating the signal horn

– Push the signal horn button (1).

The signal horn sounds.

i NOTE

The signal horn is used to warn people against imminent danger or to announce your intention to overtake.

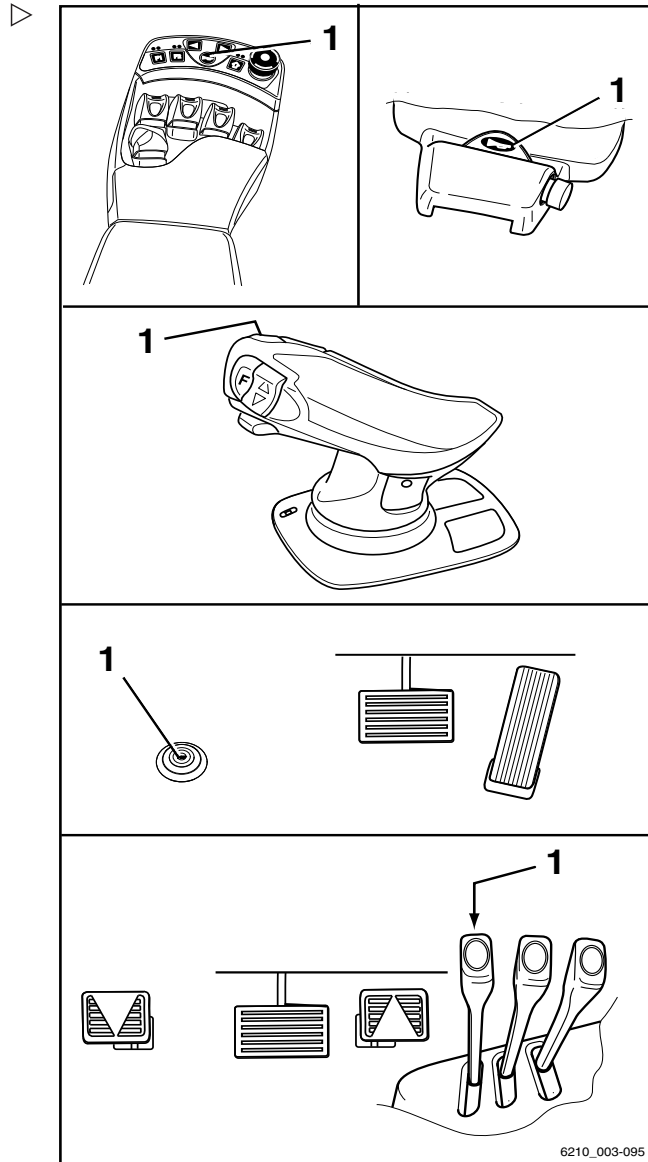

Driver's cab

⚠ DANGER

Risk of fatal injury in the event of falling from the truck if it tips over!

In order to prevent the driver from sliding underneath the truck and being crushed if the truck tips over, a restraint system must be in place and must be used. The restraint system prevents the driver from being thrown from the truck if it tips over. The driver's cab constitutes a driver restraint system only if the cab door is sturdy and closed. Fabric-covered cabs (variant) with doors made of plastic or canvas do not constitute a driver restraint system and offer no protection from the consequences of the truck tipping over!

- Close the cab door before operation
- If the door is open or has been removed, use a comparably secure restraint system
- We recommend that you always use the seat belt

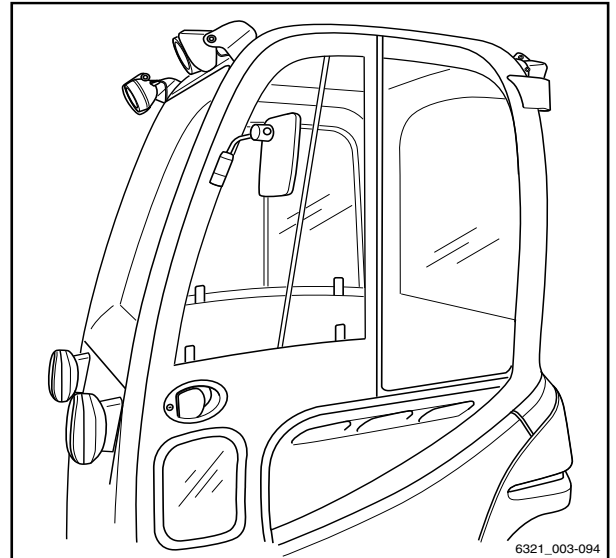

Checks and tasks before daily use

Checking the brake system for correct function

⚠ DANGER

Risk of accident in the event of failure of the brake system!

If the brake system fails, the truck will be insufficiently braked.

- Do **not** operate the truck if the brake system is faulty.

Checking the electric brake

⚠ DANGER

Risk of accident if the braking effect of the electric brake is inadequate!

The braking effect of the electric brake may be insufficient for emergency braking.

- Always actuate the brake pedal (1) for emergency braking.

⚠ DANGER

Risk of accident due to excessive speed!

Depending on the charge state of the battery, regenerative braking may be insufficient when driving downhill, meaning that the maximum permissible speed of the truck is exceeded.

- Press the brake pedal (1).

If the driving speed is restricted or if the opposite drive direction is selected, the truck is braked using the electric brake.

- To actuate this, release the accelerator pedal (2).

The truck must decelerate and remain stationary.

- If the truck does not slow down, press the brake pedal (1).

Checking the service brake

- Release the parking brake.
- Press the brake pedal (1).

There must be a slight pedal clearance and then a noticeable brake pressure point.

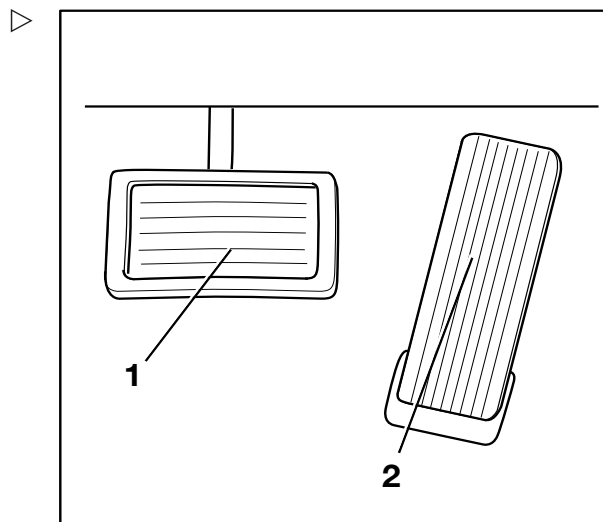

- Accelerate the unladen truck in a clear area.
- Press the brake pedal (1) firmly.

The truck must decelerate noticeably.

Checking the parking brake on a gradient or a ramp



⚠ DANGER

Risk to life if the truck rolls away!

If the parking brake is not applied, the truck could run people over.

- Do not leave the truck until the parking brake has been applied.

- Stop the truck on a steep gradient (e.g. a ramp) and actuate the parking brake.

The parking brake must hold the truck on the incline.

- If the truck rolls away despite the parking brake being applied, stop the truck using the service brake.
- In an emergency, secure the truck with wedges on the downhill-facing side to prevent it from rolling away.
- Have the parking brake checked and repaired by the authorised service centre.

Checking the parking brake on a level surface

⚠ WARNING

Risk of accident from abrupt deceleration!

The truck will decelerate abruptly if the parking brake is applied.

- Fasten the seat belt.
 - Use the available restraint systems.
-
- Find a sufficiently large and open area in which nobody will be endangered or obstructed.
 - Accelerate the truck to walking speed.
 - Press the emergency off switch.

Checks and tasks before daily use

NOTE

When the emergency off switch is actuated, note the following:

- *The electric brake is disabled. The truck no longer responds to the command issued by the accelerator pedal.*
- *The power steering is no longer available. Steering forces are increased due to the remaining emergency steering function.*
- Release the accelerator pedal.
- Apply the parking brake.

The truck must decelerate and remain stationary.

- If the truck only coasts and does not decelerate or decelerates only slightly, stop the truck using the service brake.
- Secure the truck with chocks so that the truck does not roll away.
- Have the parking brake checked and repaired by the authorised service centre.

NOTE

Special features of the electrical parking brake:

- *The deceleration cannot be influenced.*
- *The electrical parking brake is applied moderately until the truck comes to a stop.*
- *The emergency off switch must be unlocked to release the electrical parking brake.*

Checking the steering system for correct function

DANGER

If the hydraulics fail, there is a risk of accident as the steering characteristics have changed.

- Do not operate the truck if it has a defective steering system.
-
- Operate steering wheel (1). The steering play while stationary must not be more than two finger widths.

NOTE

If the truck is switched on with the steering wheel turned, the maximum driving speed is limited. Travel speed limitation is removed as soon as the steering wheel is moved out of a cornering position into the straight-ahead position. This requires a change in steering angle of about half a revolution.

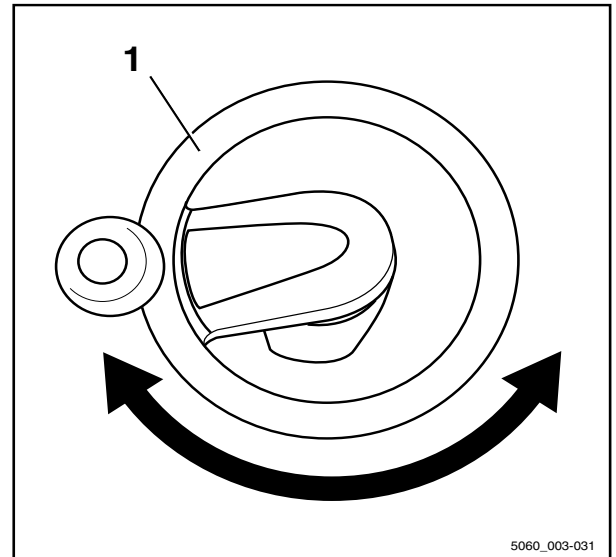

4 Operation

Checks and tasks before daily use

Checking the emergency off function ▷

⚠ WARNING

No electric braking assistance is available when the emergency off switch is actuated!

Actuating the emergency off switch will disconnect the drives from the power supply.

- To brake, actuate the service brake.

i NOTE

The mounting position of the emergency off switch can also be on the steering column in the multiple-lever version (II).

- Drive the truck forwards slowly.
- Push the emergency off switch (1).

The truck will coast.

The display and operating unit shows the message EMERGENCY OFF SWITCH periodically.

- Brake the truck to a standstill by actuating the brake pedal.

i NOTE

In trucks with an electric parking brake, the electric parking brake will be applied as soon as the truck comes to a stop.

- Turn the emergency off switch (1) clockwise and pull it out.

The truck performs an internal self-test and is then ready for operation again.

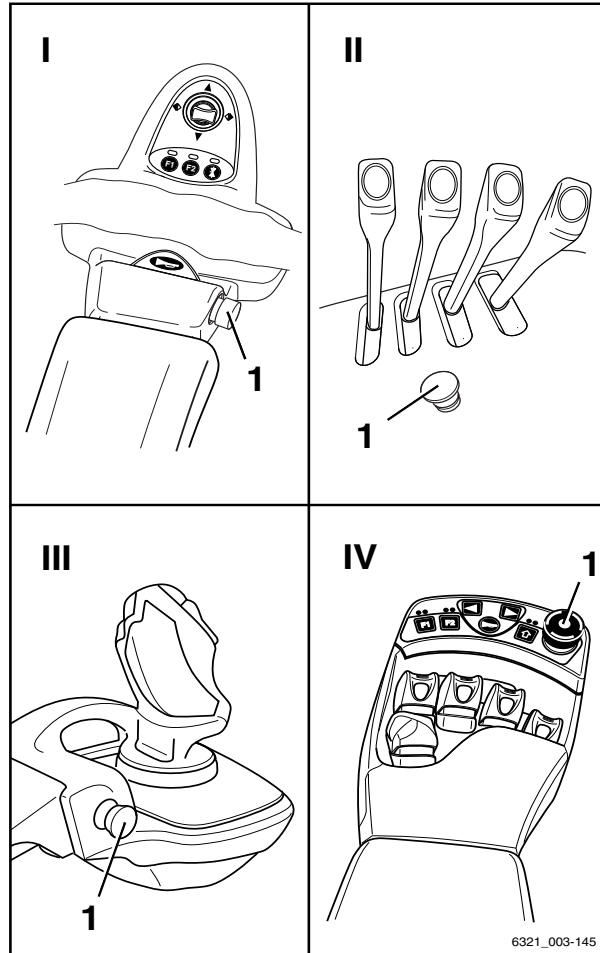



- I Mini-lever version
- II Multiple-lever version
- III Joystick 4Plus version
- IV Fingertip version

Checking the vertical lift mast position (variant) for correct function

NOTE

The function check of the lift mast vertical position (variant) must be carried out every time a truck is commissioned.

- Press the Softkey  (1).

The comfort feature "lift mast vertical position" is switched on. The symbol  (2) is displayed.

- Tilt the lift mast backwards.

The lift mast must tilt back fully and move gently as far as the end stop.

- Tilt the lift mast forward.

The lift mast must tilt forwards and stop in the vertical position.

- Release the operating device to tilt and actuate again.

The lift mast must tilt forwards fully and move gently as far as the end stop.

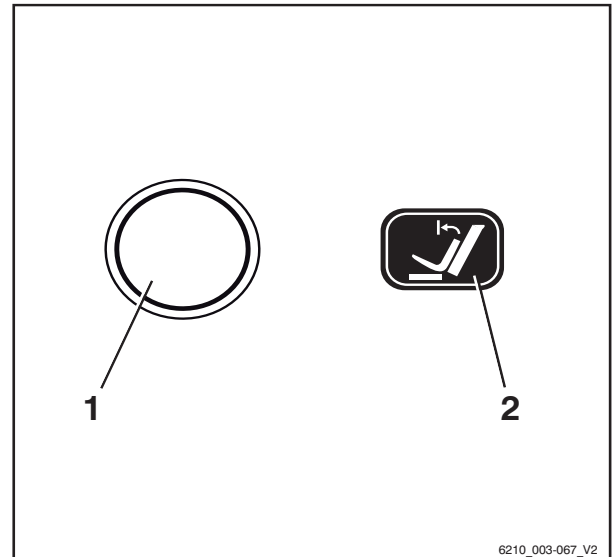

Zero adjustment of the load measurement (variant)

NOTE

A zero adjustment must be carried out in order to guarantee the accuracy of the load measurement (variant) at all times. Zero adjustment is required

- Before daily use
- after changing the fork arms
- after fitting or changing attachments.

NOTE

Accurate zero adjustment is only possible if the fork is not carrying a load. Do not take up a load yet.

4 Operation

Checks and tasks before daily use

i NOTE

Accurate zero adjustment is only possible within the first lifting stage of the lift mast. When carrying out the zero adjustment, do not raise the fork more than 800 mm above the ground.

i NOTE

The way in which the lifting system is operated depends on the operating devices included in the truck's equipment; see the chapter entitled "Lifting system operating devices".

- Set lift mast to vertical.
- Raise the fork to a height of 300-800 mm.
- Press the Softkey (1).

The zero adjustment of the load measurement is switched on. The symbol is displayed. The message LOWER FORKS appears on the display.

i NOTE

During the following process, the fork carriage must be lowered slightly and then stopped abruptly. While doing so, the fork must not touch the ground, otherwise the zero adjustment will not be accurate. To stop the lowering procedure quickly, release the operating device for lowering so that it jumps into the zero position.

- Lower the fork carriage slightly and release the operating device.

When the zero adjustment has been carried out correctly, the value "0 kg" appears on the display.

- The zero adjustment of the load measurement is completed. The symbol (2) is displayed.

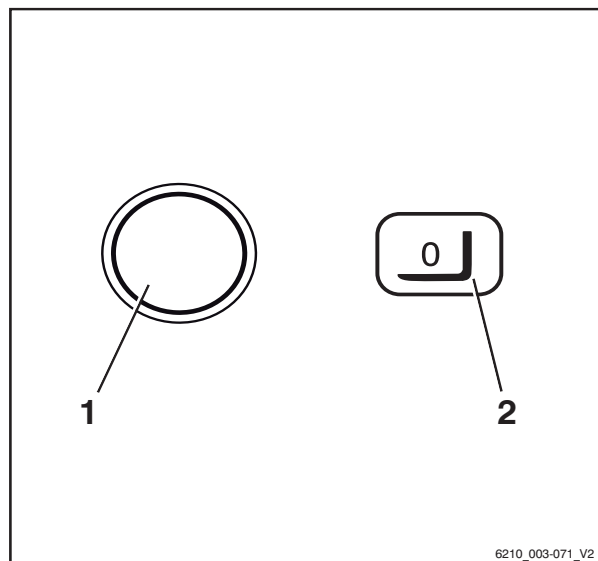

Switching on

Switching on the key switch

⚠ WARNING

Before switching on the key switch, all tests and operations prior to commissioning must be performed without any defects being detected.

- Carry out checks and operations before commissioning.
- Do not operate the truck if defects have been detected; contact the authorised service centre.

NOTE

When the truck is switched on, the maximum driving speed is restricted. The driving speed limitation is disabled as soon as the truck is steered out of cornering to drive in a straight line. To do this, rotate the steering wheel by approximately half a turn.

- Insert switch key (1) into the key switch and turn to position "I".

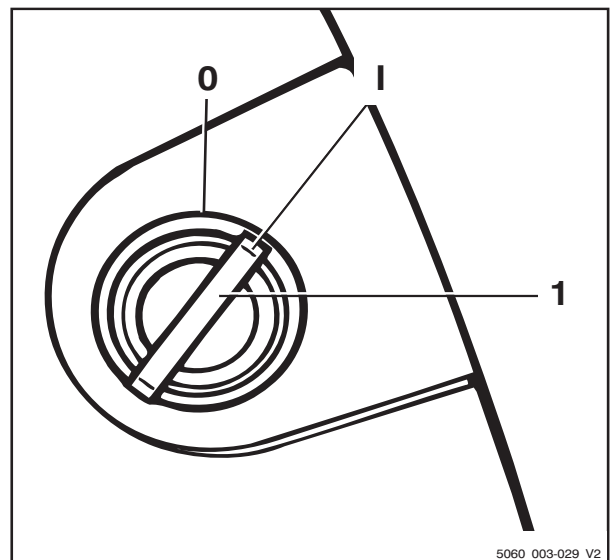

4 Operation

Switching on

This initiates a self-test. All lamps in the drive direction and turn indicator displays light up briefly.

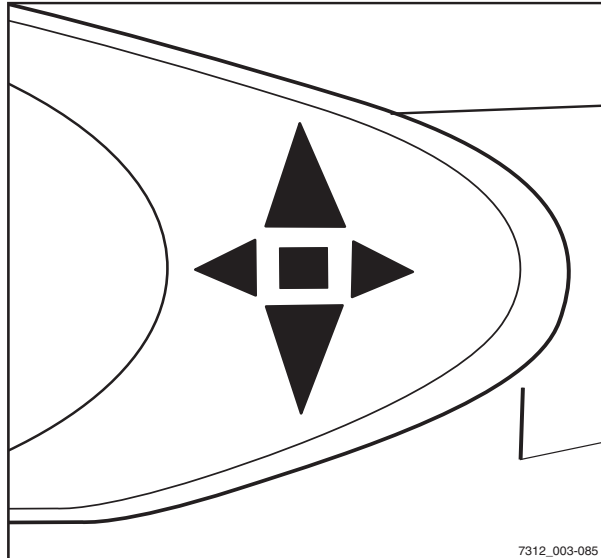

7312_003-085

When the key switch is switched on, the display shows the welcome screen in the set language until the truck controller has fully started up.



If the truck is ready for operation, the standard displays are shown.

If the truck is equipped with the "access authorisation with PIN code" variant, the display initially changes to the input menu for access authorisation.



Standard display elements

- 1 **Battery charge**
The available battery capacity is shown in the display field.
- 2 **Drive program**
The current traction program (1–5) appears on the display.
- 3 **Power rating**
The average power consumption and consumption trends are shown in the display field.
- 4 **Time**
The current time appears in the display field.

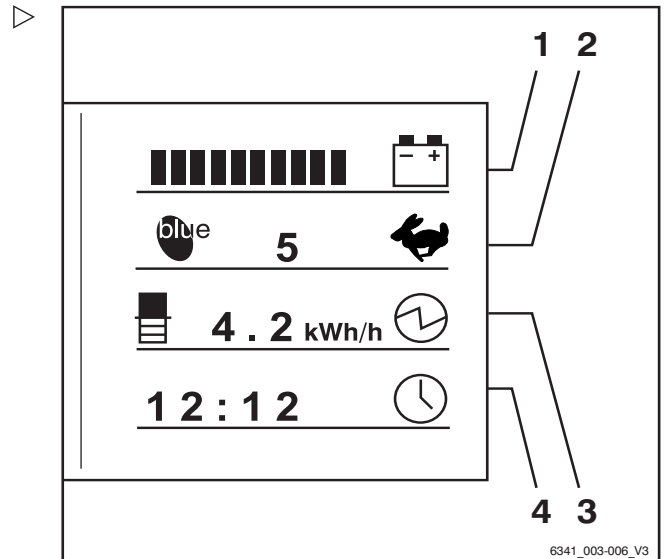

NOTE

After connecting the battery, the correct charging state may not be displayed until the battery is placed under load in the form of driving or lifting operations.

Additional information may appear on the display.

- If malfunctions occur, refer to the information in the chapter entitled "Display messages".

Access authorisation with PIN code (variant)

Description

Trucks equipped with the "Access authorisation with PIN code" variant are protected against unauthorised use by a five-digit driver PIN. Up to fifty different driver PINs can be defined so that the same truck can be used by different drivers, each with their own driver PIN.

NOTE

The driver PINs are defined in a truck control unit menu that can only be accessed by persons with the corresponding access authorisation, e.g. fleet managers.

Switching on

Once the key switch has been switched on, the input menu for the driver PIN appears on the display and operating unit screen. All of the truck's functions (driving, hydraulics, additional electrical installations and the display and operating unit displays) are blocked. The function of the hazard warning system (variant) is guaranteed. Enter the five-digit driver PIN (possible entries from 00000 to 99999) to enable the blocked functions. Once the correct driver PIN has been entered, the standard displays are shown. All of the truck functions are available.

The access authorisation can be configured in such a way that the driver PIN has to be re-entered each time the driver steps off the truck, in order for the truck to be operated again.

- Contact the authorised service centre on this matter.

The first driver PIN is preset to "11111" at the factory. All others are preset to "0xFFFF" but have no function as the highest valid driver PIN is "99999". Persons with the appropriate access authorisation, e.g. fleet managers, can change the driver PINs in the corresponding menu.

NOTE

When first commissioning the truck, we recommend you change the access authorisation set at the factory. This is the only way to guarantee that the driver PIN is only known to persons with corresponding access authorisation.

The driver PINs are stored in the truck control unit. These are still available if the display and operating unit has been changed. The authorised service centre can use a diagnostic device to read out the driver PIN and, if necessary, restore the factory default driver PIN.

ACCESS CODE input menu

The driver enters the five-digit driver PIN (00000 to 99999) in this input menu.

The driver PIN is entered using the buttons or Softkeys (1). The digits entered for the driver PIN (2) are not visible but are represented by circles instead. If the driver PIN entered is correct, the familiar screen appears with the standard display, and all truck functions are available.

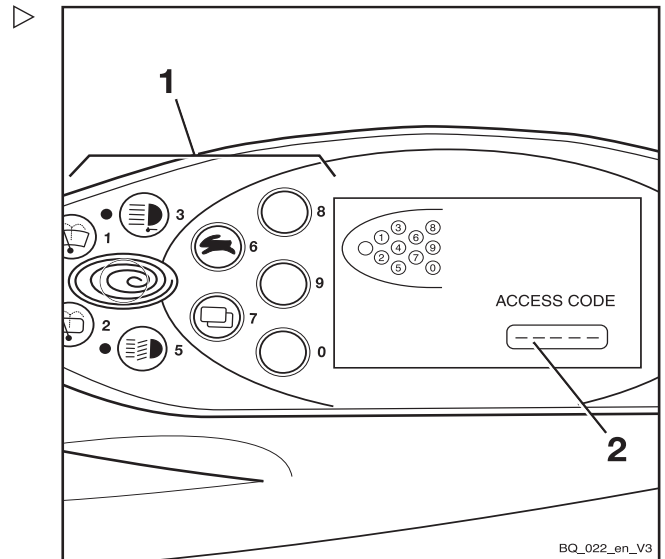

If an incorrect driver PIN is entered, the message **INVALID** appears for a short time. When the message goes out, the driver PIN can be re-entered.

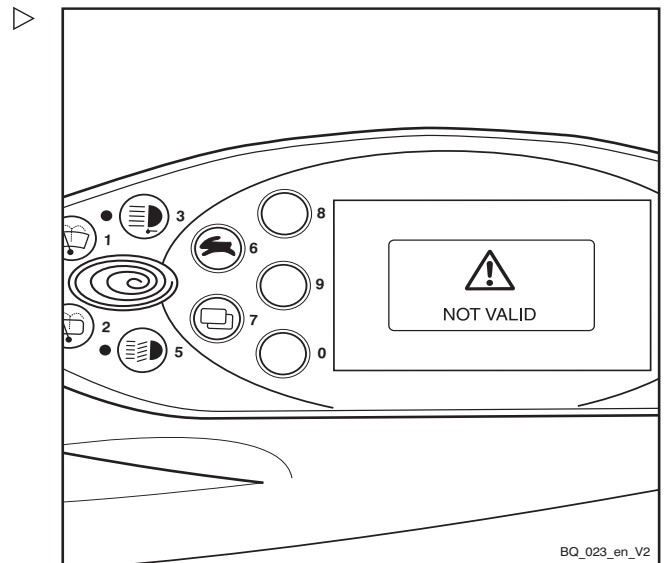

4 Operation

Switching on

After three invalid entry attempts, the message CODE DENIED appears. The input is then locked for five minutes before another attempt can be made.

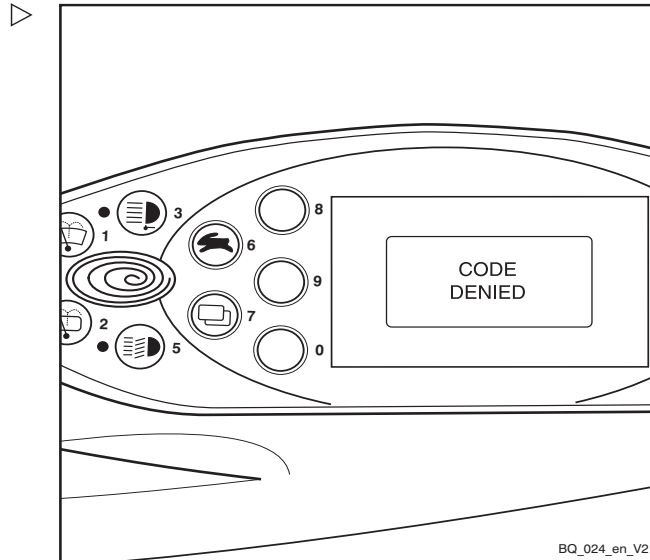

Defining the driver PIN

i NOTE

The driver PINs can be defined only by persons with the appropriate access authorisation, e.g. fleet managers. To set the driver PIN, the fleet manager must access the configuration menu. The configuration menu is password-protected. After entering the password, the fleet manager can configure general settings for the truck. To change the password, see the chapter entitled "Changing the password".

- Push the drive program selection button (1) and the menu change button (2) at the same time.

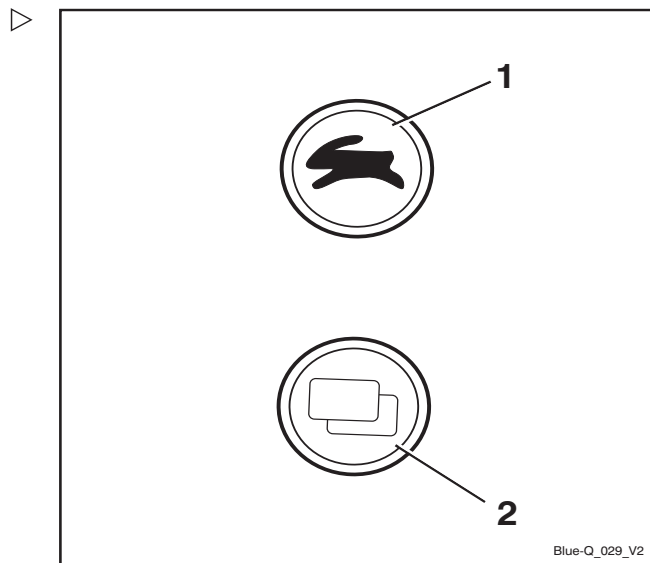

Operation

4

Switching on

PASSWORD appears in the display.

- Enter the four-digit password (factory default: 2777) using the buttons (1).
- Confirm the input using Softkey  (2).

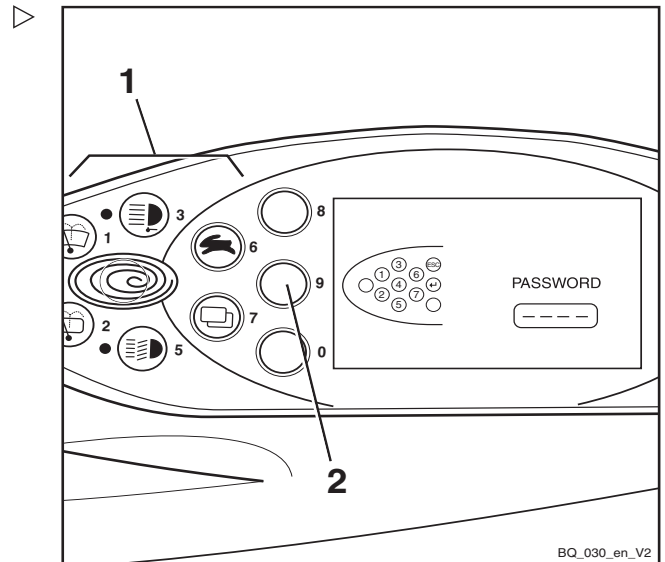

CONFIGURATION appears in the display.

- Use the drive program selection button (1) and the menu change button (3) to select the ACCESS CODE menu.
- Confirm your selection using Softkey  (2).

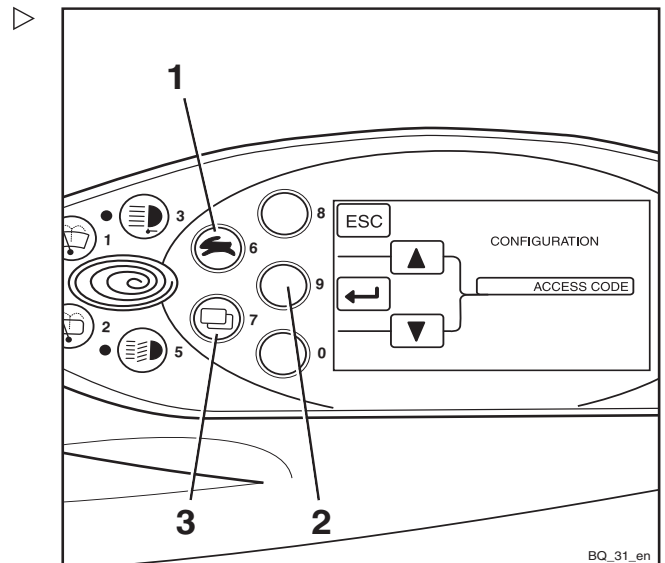

4

Operation

Switching on

Selecting the driver PIN

In the ACCESS CODE menu, there are fifty possible driver PINs to choose from.

The digit sequences can be set or changed in the NEW CODE submenu.

Once the ACCESS CODE menu has been accessed, the CODE selection field (2) contains the number 1. The first of the fifty driver PINs can now be defined.

- Use the drive program selection button (1) and the menu change button (4) to select the desired driver PIN (1 to 50).
- Confirm your selection using Soft-key (↵)(3).

NEW CODE appears in the display.

- Enter the desired driver PIN using the buttons or Softkeys (5).

The digits entered do not appear in the display. Instead they are represented by circles in the NEW CODE field (6).

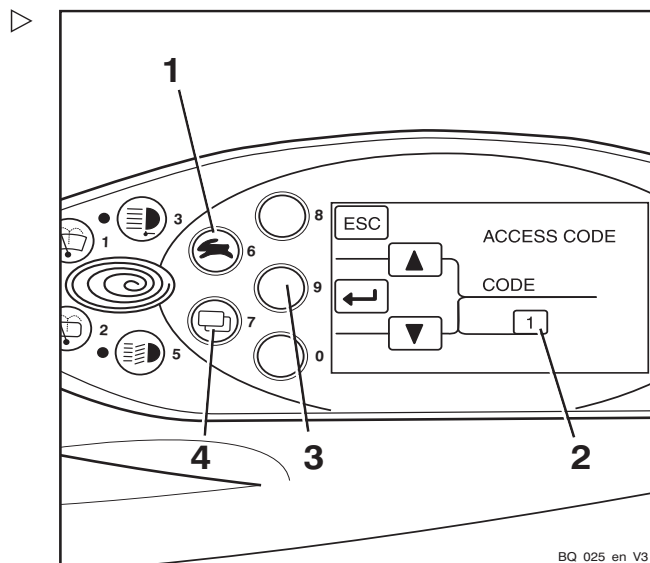

BQ_025_en_V3

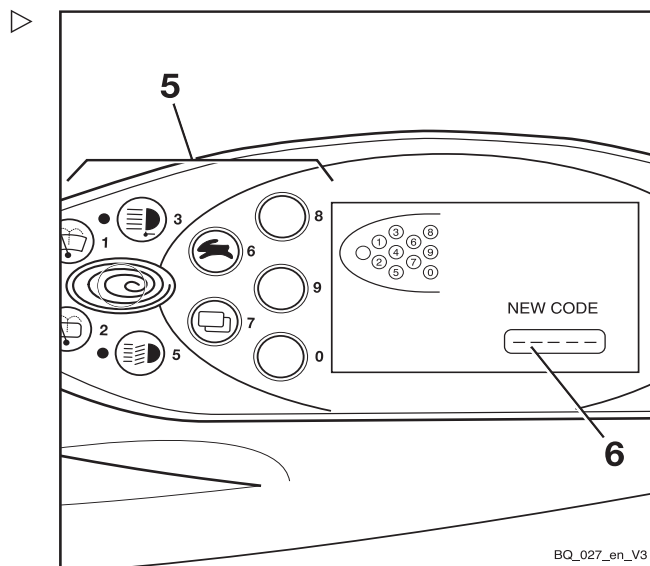

BQ_027_en_V3

Operation

4

Switching on

CONFIRM appears in the display.

The CONFIRM submenu is used to confirm the new driver PIN.

- Enter the new driver PIN for a second time in the CONFIRM field (8) using the buttons or Softkeys (7).

If the entry matches the new driver PIN previously entered, the system will accept the new driver PIN once the last digit has been entered. The display switches back to the ACCESS CODE menu.

Another driver PIN can be defined here.

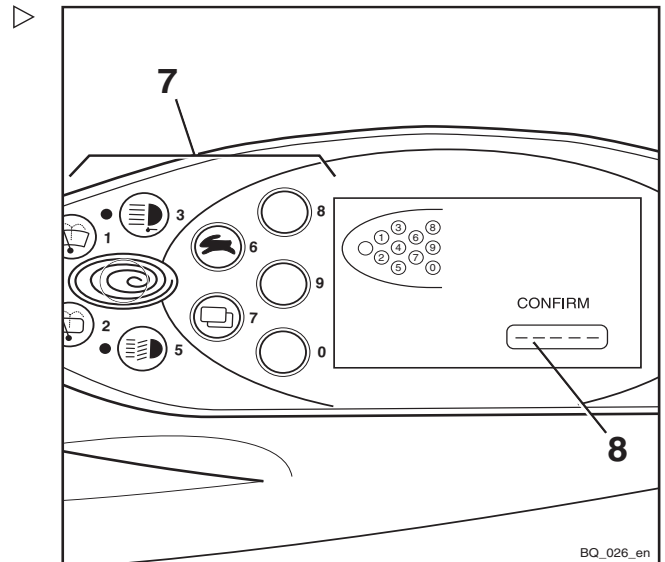

If the driver PIN entered in the CONFIRM submenu does not match the driver PIN entered previously in the NEW CODE submenu, the message INVALID will appear.

The message will then disappear after a short time. The new driver PIN can be entered in the CONFIRM submenu for further confirmation.

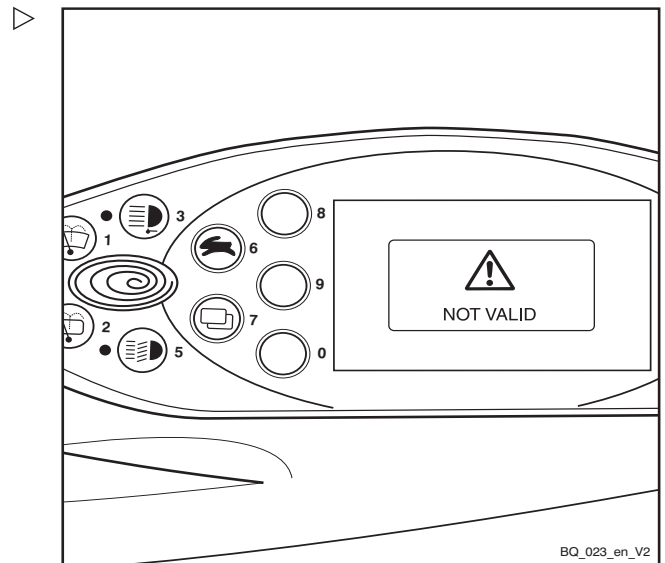

4 Operation

Switching on

After three incorrect entries, the CODE DENIED message appears.

The display switches back to the ACCESS CODE menu. The desired driver PIN must be re-defined.

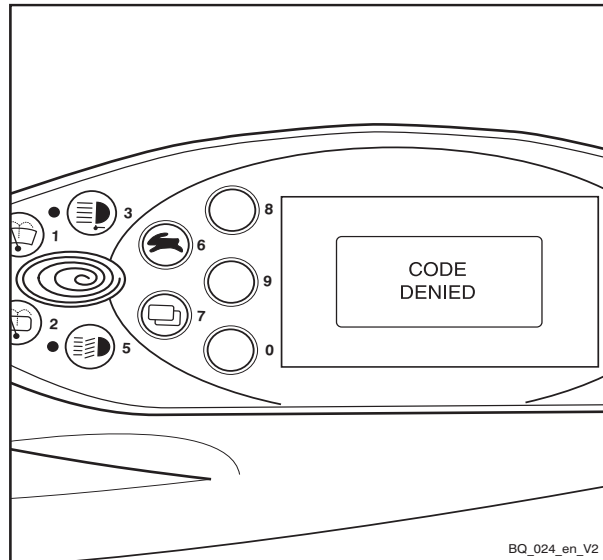

Changing the password

It is recommended that you change the factory default password.

i NOTE

The password can only be changed when the parking brake is applied.

- Push the drive program selection button (1) and the menu change button (2) at the same time.

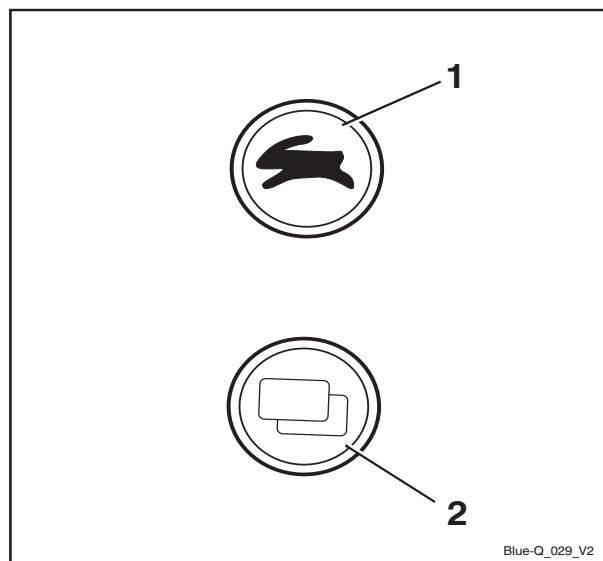

Operation

4

Switching on

PASSWORD appears in the display.

- Enter the current password using the buttons (1).
- Confirm the input using Softkey (2).

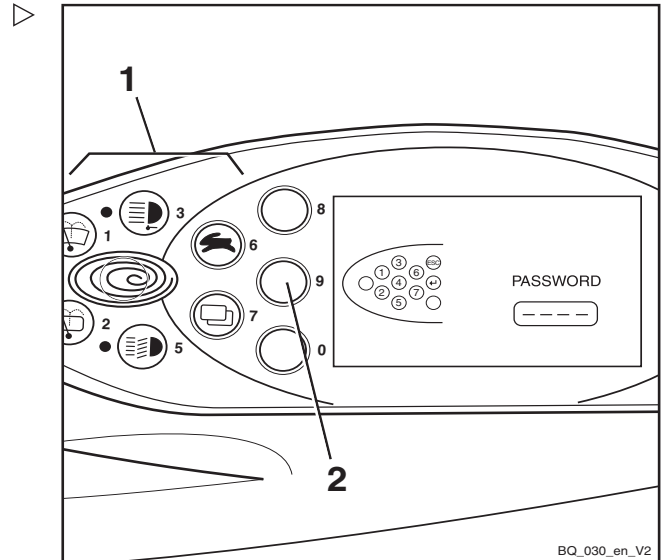

CONFIGURATION appears in the display.

- Use the drive program selection button (1) and the menu change button (3) to select the PASSWORD menu.
- Confirm your selection using Softkey (2).

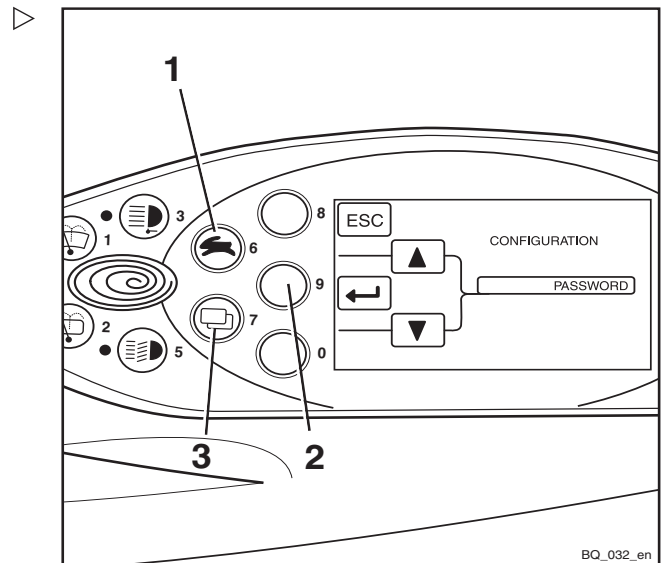

4

Operation

Switching on

PASSWORD/PASSWORD LEVEL appears in the display. ▷

- Use the drive program selection button (1) and the menu change button (4) to select the desired PASSWORD LEVEL (2).
- Confirm your selection using Soft-key (↵)(3).

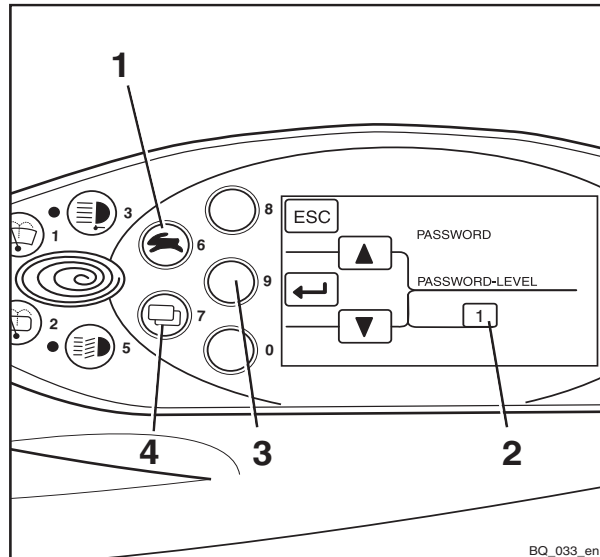

NEW CODE appears in the display. ▷

The four-digit password can be entered using the buttons (1).

CAUTION

Do not enter the password 1777!

If this password is entered, the configuration options for the fleet manager are restricted to driver authorisations and cannot be reset independently. The authorisations can only be reset by the authorised service centre!

- Enter the new desired password using the buttons (1).

The digits entered are shown in plain text in the NEW CODE field (4).

- Confirm your selection using Soft-key (↵)(3).

In the NEW CODE field, - ?? - appears briefly. The new password is confirmed.

- Press Softkey (ESC)(2) to correct the new password.

The display switches back to PASS - WORD/PASSWORD LEVEL.

- Repeat the process steps from PASS - WORD/PASSWORD LEVEL.
- To exit the configuration menu, press Softkey (ESC)(2) repeatedly until the standard display appears.

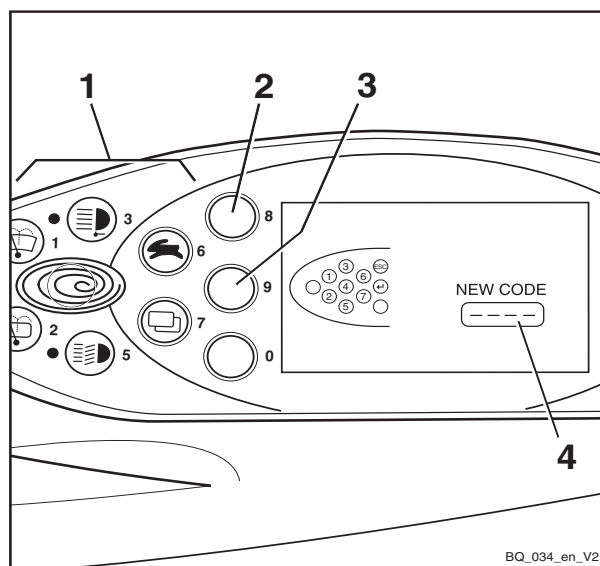

Display-operating unit

Indicators

Standard displays

In the factory setting, the following indicators can be seen in the display and operating unit:

1 **Battery charge** 

Displays the available battery capacity as a segmented bar graph in 10% increments.

Approx. every 10 seconds, the display switches from showing the battery charge to the remaining operating time.

If a different drive program or a different drive mode (e.g. Blue-Q) is selected, the system immediately recalculates the remaining operating time and indicates for how long the truck can be driven if the operating situation of the last 30 minutes is maintained.

2 **Drive program** 

Displays the number of the selected drive program. To change the drive program, refer to the section entitled "Setting the drive program".

The Blue-Q icon  appears when the Blue-Q function is switched on; refer to the section entitled "Blue-Q efficiency mode".

3 **Power rating** 

The power rating indicator shows the average energy consumption over the last 30 minutes in kilowatts (kW).

Trends relating to the current energy consumption are displayed as a vertical bar graph . The percentage change in each bar is shown in the table under "Power trends indicator" below.

4 **Time** 

Displays the current time digitally in hours and minutes. The time can be adjusted; see the chapter entitled "Setting the time".

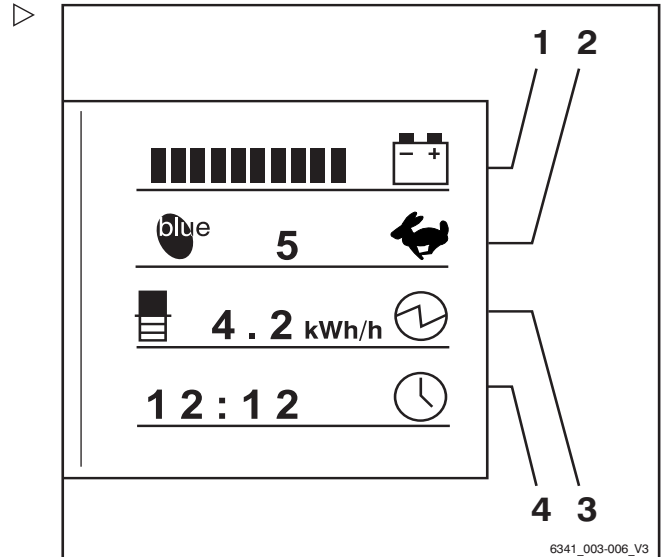



4 Operation

Display-operating unit

⚠ CAUTION

Deep discharges shorten the service life of the battery.

If no bar is shown (0% of the available battery capacity, i.e. around 20% of the nominal capacity), deep discharge begins.

- Deep discharge (no bar on the display) must be avoided.
- Cease work with the truck immediately.
- Charge the batteries immediately.

i NOTE

To prevent deep discharge, certain restrictions (variant) can be activated (e.g. slow lifting). Consult the authorised service centre on this matter.

Power trends indicator

Symbol	Energy consumption trend
	Significant increase (> 50%)
	Increase (up to 50%)
	Slight increase (up to 30%)
	No change
	Slight decrease (up to -30%)
	Decrease (up to -50%)
	Significant decrease (> -50%)

Additional indicators

5 Menu change button

When the menu change button is pressed, the following additional indicators appear:

6 "Service in" display

Displays the remaining time in operating hours until the next maintenance operation is due according to the maintenance schedule in the maintenance instructions. Contact the authorised service centre in good time.

7 Operating hours

Displays the total operating hours completed by the truck. The hour meter starts running as soon as the truck is driven or the working hydraulics are actuated.

8 Total distance

Displays the total distance driven in kilometres.

9 Daily kilometres

Displays the kilometres driven for the day.

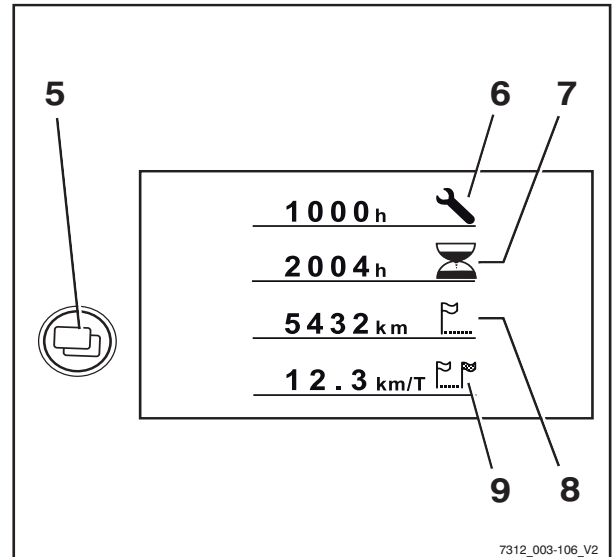

NOTE

Ask the authorised service centre about the speed driven indicator.

NOTE

Have all repair and maintenance work performed by an authorised service centre. This is the only way to permanently correct defects.

- Inform the authorised service centre when the maintenance interval is reached.

Adjusting the displays

NOTE

The parking brake must always be engaged when you adjust the displays. The displays cannot be adjusted if the parking brake is not engaged.

4 Operation

Display-operating unit

i NOTE

When adjusting the displays, do not actuate the hydraulic system operating devices. If you do, entry is interrupted and the display returns to the operating display.

The displays are adjusted in the CONFIGURATION menu.

- Turn the key switch to position "I".
- Press the drive program button (1) and the menu change button (2) at the same time. ▷

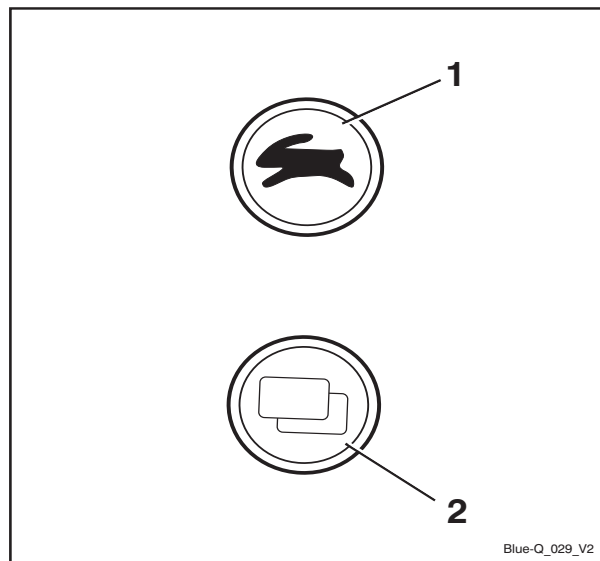

The display changes to the PASSWORD menu. ▷

i NOTE

It may be necessary to enter a password in order to configure the displays. This depends on the configuration of the display-operating unit.

- For configuration of the display-operating unit, contact the authorised service centre

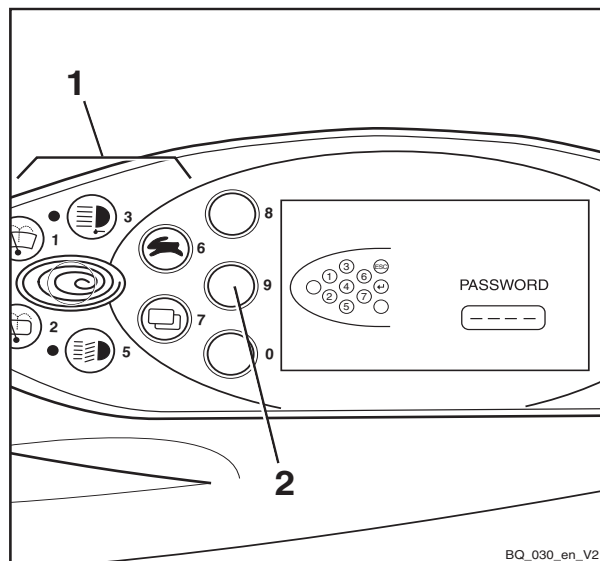

- Press the Softkey (3).

The display changes to the CONFIGURATION menu.

The following settings are possible and can be found in the corresponding chapter:

- Setting the date and time
- Resetting the daily kilometres and daily operating hours
- Setting the language
- Configure Blue-Q

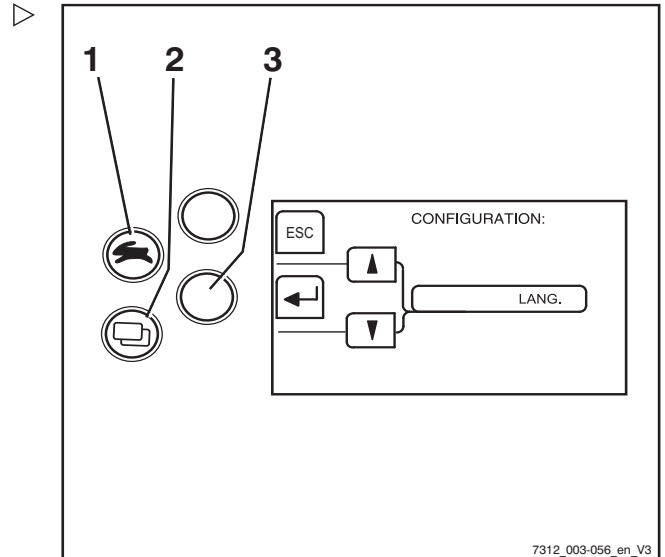

Symbols in the display

Messages

To show operating messages, warning messages or error messages in the display, text messages and symbols are used.

Symbols for operating messages

Description	Symbol
Empty field	No display
Please wait	
Service required	
Lift limitation	
Reference cycle	
Battery charging	
Drive program	
Hour meter	
Odometer	
Daily hour meter	
Daily odometer	
Speed	
Steering angle	

4 **Operation**

Display-operating unit

Description	Symbol
Load	
Time	
Hydraulic system	
Exh.gas purifier	
Coolant temperature	
Fuel level	
Blue-Q	
Power rating (average)	
Power rating (trend)	

Symbols for warning messages

Description	Symbol
Parking brake	
Actuate seat switch	
Safety belt	
Battery acid level	
Neutral warning message	
Are you sure?	
Oil pressure	

Symbols for error messages

Description	Symbol
Brake system malfunction	
Overheating of the engine	
Overheating	
Malfunction in the electrical system	
General malfunction	

Symbols for softkey functions of auxiliary equipment

The following symbols for softkey functions are used on the left of the display for auxiliary equipment:

Description	Symbol
Empty field	No display
General function OFF	
General function ON	
Rear working spotlight OFF	
Rear working spotlight ON	
Front working spotlight OFF	
Front working spotlight ON	
Windscreen heating OFF	
Windscreen heating ON	
Rear window heating OFF	
Rear window heating ON	
Interior lighting OFF	
Interior lighting ON	
Roof wiper/washer OFF	
Roof wiper/washer ON	
Heater blower OFF	
Heater blower ON	
Rotating beacon OFF	
Rotating beacon ON	
Seat heater OFF	
Seat heater ON	
Signal horn OFF	
Signal horn ON	
Cruise control OFF	
Cruise control ON	
Automatic mast vertical positioning OFF	
Automatic mast vertical positioning ON	

Display-operating unit

Description	Symbol
Load measurement zero adjustment OFF	
Load measurement zero adjustment ON	
Load measurement OFF	
Load measurement ON	

Symbols for softkey functions for menu navigation and for acknowledging messages

The following symbols for the softkey functions are used on the left of the display for menu navigation and to acknowledge messages:

Description	Symbol
Empty field	No display
Cancel input	
Confirm input	
Confirm information	
Reset	
Back by one menu level	
Back to the previous edit field	
Scroll up	
Scroll down	
Count up	
Count down	

Status LEDs of the function keys for additional electrical installations

The current switch status of a button is indicated with LEDs next to the relevant function key for the additional electrical installation.

Description	LED
Function off	LED OFF
Function on	LED ON

Symbols for numeric keypad

The buttons and Softkeys that can be used to enter numbers and to cancel or confirm input values are shown in the display.

Screen for entering the fleet manager password: ▷

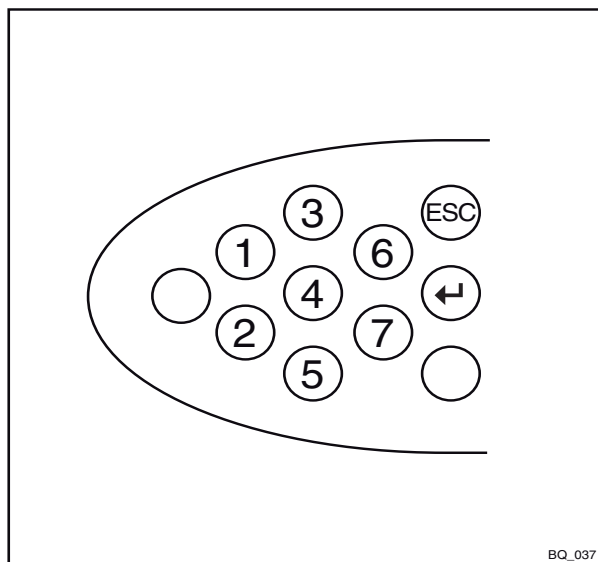

Screen for entering the driver PIN (access code): ▷

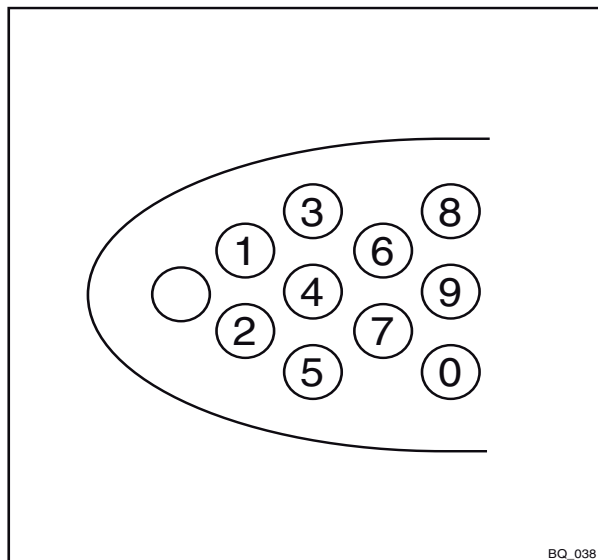

4 Operation

Display-operating unit

Setting the date or time

- Switch to the CONFIGURATION menu; see the chapter entitled "Adjusting the displays".
- Press the Drive programme button (1) or the Menu change button (2) repeatedly until the TIME option appears.
- Confirm your selection using the Softkey (↵) (4).

The TIME menu appears.

- Press and hold down the Drive programme button (1) or Menu change button (2) until the desired time appears on the display.

As the buttons are held down for longer, the scrolling speed increases in three levels.

- Confirm the set time using Softkey (↵) (4).
- Use the Softkey (←) (3) to exit the menu and return to the next level up.

i NOTE

The date is set in a similar manner.

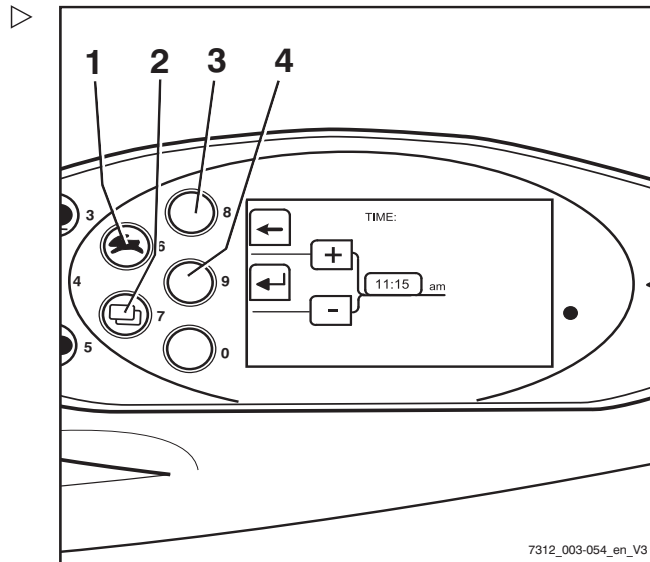

7312_003-054_en_V3

Resetting the daily kilometres and daily operating hours

The daily number of kilometres and daily operating hours displays can be reset to zero:

- Switch to the CONFIGURATION menu; see the chapter entitled "Adjusting the displays".
- Press the Drive programme button (1) or the Menu change button (2) repeatedly until the DAY KM option appears.
- Confirm your selection using the Softkey (↵) (4).

The DAY KM menu appears.

- Reset the displayed mileage using Softkey (RES) (4).
- Use the Softkey (←) (3) to exit the menu and return to the next level up.

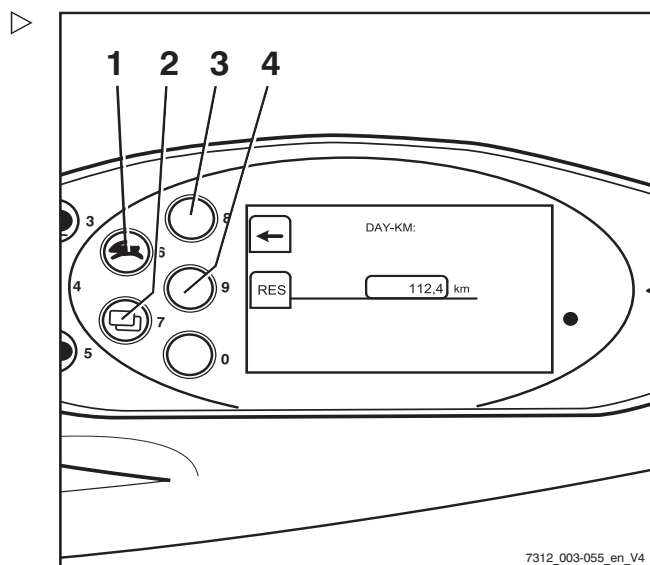

7312_003-055_en_V4

i NOTE



The daily operating hours are reset in the same manner.

Setting the language

The displays can be shown in additional languages:

- Switch to the CONFIGURATION menu; see the chapter entitled "Adjusting the displays".
- Press the drive programme button (1) or the menu change button (2) repeatedly until the LANGUAGE option appears.
- Confirm your selection using the Soft-key  (4).

The LANGUAGE menu appears.

- Press drive program button (1) or menu change button (2) until the desired language appears in the display.
- Confirm your selection using the Soft-key  (4).
- Use the Softkey  (3) to exit the menu and return to the next level up.

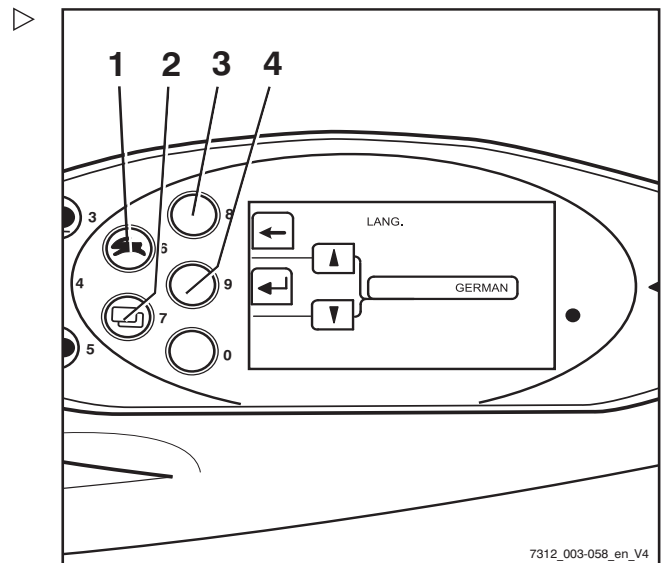

7312_003-058_en_V4

Softkeys for operating various equipment variants

Additional functions can be displayed on the display-operating unit. These additional functions, e.g. a rotating beacon, can be switched on and off using Softkeys.

4

Operation

Display-operating unit

Changing the Softkey functions:

A grey bar (3) highlights the Softkey column. This is the right-hand column in the example shown here. These additional functions can now be switched on and off via the corresponding Softkeys (2). The right-hand column is only populated with additional functions if the truck has more than three equipment variants that can be switched on and off using Softkeys.

In this case, proceed as follows to switch between the two columns:

- Briefly press the Menu change button (1).

The grey bar jumps to the left-hand column. These additional functions can now be switched on and off via the corresponding Softkeys (2).

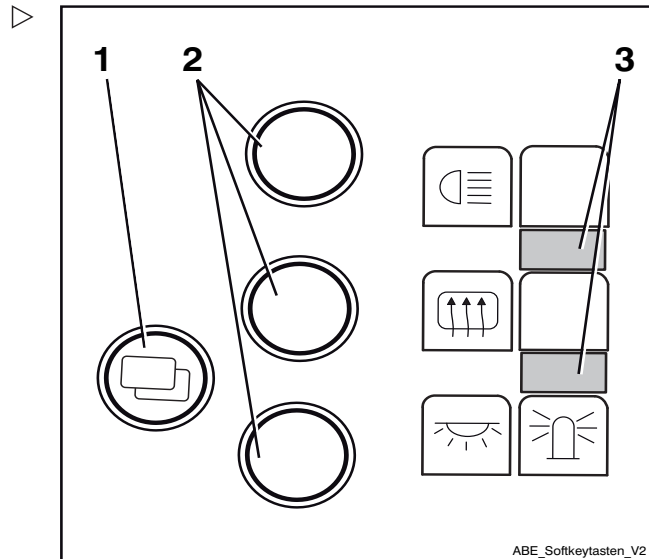

i NOTE

Press the Menu change button (1) for approx. 1 second to switch between the individual menus on the display-operating unit.

i NOTE

The additional functions depend on the individual equipment of the truck and may vary from those shown here.

Blue-Q efficiency mode

Functional description

The Blue-Q efficiency mode affects both the drive unit and the activation of the additional consumers, and reduces the truck's energy consumption.

If the efficiency mode has been activated, the acceleration behaviour of the truck changes to make acceleration more moderate.

When travelling at low speeds—normally when manoeuvring—no reduction is noticeable despite the activated efficiency mode. For moderate speeds of at least approx. 7 km/h, acceleration is gentler. Therefore, on distances of up to approx. 40 m, lower speeds are reached than would be the case if the efficiency mode was not activated.

Blue-Q has no influence on:

- Maximum speed
- Climbing capability
- Traction
- Braking characteristics

NOTE

The Blue-Q efficiency mode can be switched on and off in the STANDARD and FIXED-FLEX operating modes. If the FIXED operating mode is configured in the display operating unit, the Blue-Q button has no function and the Blue-Q efficiency mode is switched on permanently; see also chapter "Configuring Blue-Q efficiency mode".

Blue-Q efficiency mode

Switching off additional consumers

If the Blue-Q efficiency mode is activated, the controller switches off various additional consumers after a few seconds in certain conditions. The additional consumers available depend on the truck equipment. The following table shows the conditions that cause additional consumers to be switched off. Only one of the conditions listed must be met.

Additional consumers	Condition		
	Seat switch not actuated	Truck stopped	Truck is in motion
Front working spotlights	X	X	Backwards > 3 km/h
Rear working spotlights	X	X	Forwards
Top double working spotlight	X	X	> 3 km/h
Headlights	X	X	-
Front wiper	X	X	Backwards > 3 km/h
Rear wiper	X	X	Forwards
Seat heater	X	-	-
Cab heating	X	-	-

NOTE

On the version with StVZO (German Road Traffic Licensing Regulations) equipment, the Blue-Q efficiency mode does not switch off the lighting devices headlights and working spotlights, side lights, rear lights and license plate lamps.

Switching efficiency mode Blue-Q on and off

NOTE

The Blue-Q efficiency mode can be switched on and off in the STANDARD and FIXED-FLEX operating modes. If the FIXED operating mode is configured in the display-operating unit, the Blue-Q button is disabled and the Blue-Q efficiency mode is switched on permanently. For information on

Operation

4

Blue-Q efficiency mode

configuring the Blue-Q operating modes, see the "Configuring Blue-Q efficiency mode" section.

- Press the Blue-Q button (2) to switch on Blue-Q.

The Blue-Q symbol (1) is displayed. The LED (3) illuminates in blue. Blue-Q efficiency mode is switched on.

- To switch it off, press the Blue-Q button (2) again.

The Blue-Q symbol (1) and the LEDs (3) go out. Blue-Q efficiency mode is switched off.

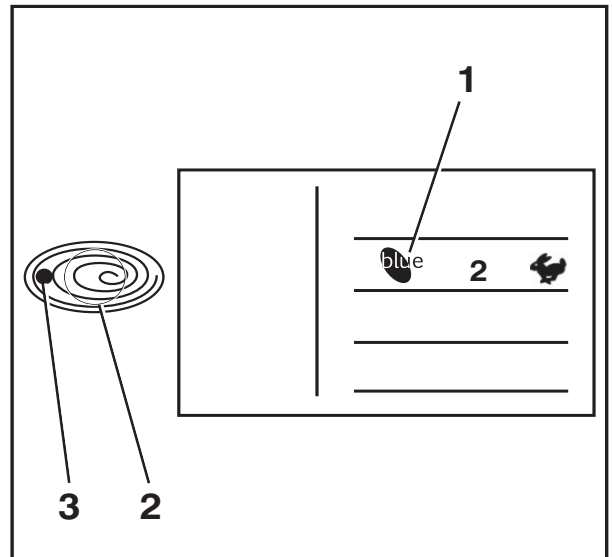

Configuring Blue-Q efficiency mode

The following operating modes can be selected to activate the Blue-Q efficiency mode:

STANDARD

- Blue-Q is turned off whenever the truck is commissioned. The driver can use the Blue-Q button to switch efficiency mode on and off at any time while the truck is being operated

FIXED

- Blue-Q is switched on permanently whenever the truck is commissioned and during truck operation. The driver cannot turn efficiency mode off

FIXED - FLEX



- Blue-Q is turned on whenever the truck is commissioned. The driver can use the Blue-Q button to switch efficiency mode on and off at any time while the truck is being operated

4 Operation

Blue-Q efficiency mode

- Switch to the CONFIGURATION menu; see the chapter entitled "Adjusting the displays".
- Keep pressing the drive programme button (1) or the menu change button (2) until option BLUE Q CONFIGURATION appears.
- Confirm your selection with Softkey  (4).

The BLUE-Q CONFIGURATION menu appears.

- Press drive program button (1) or menu change button (2) until the desired efficiency mode appears in the display.
- Confirm the set efficiency mode using Softkey  (4).
- Use the Softkey  (3) to exit the menu and return to the next level up.

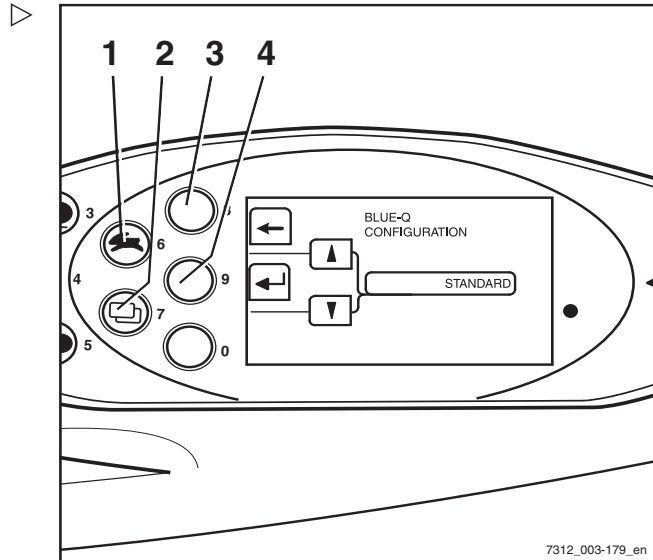

Driving

Safety regulations when driving

Driving conduct

The driver must follow the public rules of the road when driving in company traffic.

The speed must be appropriate to the local conditions.

For example, the driver must drive slowly around corners, in tight passageways, when driving through swing-doors, at blind spots, or on uneven surfaces.

The driver must always maintain a safe braking distance from vehicles and persons in front, and must always have the truck under control. Stopping suddenly, turning quickly and overtaking at dangerous or blind spots must be avoided.

- Initial driving practice must be carried out in an empty space or on a clear roadway.

The following are forbidden during driving:

- Allowing arms and legs to hang outside the truck
- Leaning the body over the outer contour of the truck
- Climbing out of the truck
- Moving the driver's seat
- Adjusting the steering column
- Releasing the seat belt
- Disabling the restraint system
- Raising the load higher than 300 mm above the ground (with the exception of manoeuvring processes during the placement into stock/removal from stock of loads)
- Using electronic devices, for example radios, mobile phones etc.



Driving

⚠ WARNING

The use of multimedia and communication equipment as well as playing these devices at an excessive volume during travel or when handling loads can affect the operator's attention. There is a risk of accident!

- Do not use devices during travel or when handling loads.
- Set the volume so that warning signals can still be heard.

⚠ WARNING

In areas where use of mobile phones is prohibited, use of a mobile phone or radio telephone is not permitted.

- Switch off the devices.

Visibility when driving

The driver must look in the drive direction and have a sufficient view of the driving lane.

Particularly for reverse travel, the driver must be sure that the driving lane is clear.

When transporting goods that impair visibility, the driver must drive the truck in reverse.

If this is not possible, a second person acting as a guide must walk in front of the truck.

In this case the driver must only move at walking pace and with extra care. The truck must be stopped immediately if eye contact with the guide is lost.

Rear-view mirrors are only to be used for observing the road area behind the truck and not for reverse travel. If visual aids (mirror, monitor) are necessary to achieve sufficient visibility, it is necessary to practise using them. For reverse travel using visual aids, extra care should be taken.

When using attachments, special conditions apply; see the chapter entitled "Fitting attachments".

Any glass (variant, e.g. windscreen) and mirrors must always be clean and free of ice.

Driveways

Dimensions of roadways and aisle widths

The following dimensions and aisle width requirements apply under the specified conditions to ensure safe manoeuvring. In each case, it must be checked whether a larger aisle width is necessary, e.g. in the case of different load dimensions.

Within the EU, Directive 89/654/EEC (minimum safety and health requirements for the workplace) must be observed. The respective national guidelines apply for areas outside of the EU.

The required aisle widths depend on the dimensions of the load.

The aisle widths for pallets are as follows:

Model	Type	Aisle width [mm]	
		With pallet 1000x1200 crosswise	With pallet 800x1200 lengthwise
RX60-35/600	6367	4208*	4408
RX60-40	6367	4208	4408
RX60-40/600	6368	4208*	4408
RX60-45	6328	4208	4408
RX60-45/600	6369	4218*	4418
RX60-50	6329	4218	4418
RX60-50/600	6330	4284*	4484

* Without taking protruding fork arms into account.

The truck may only be used on roadways that do not have excessively sharp bends, excessively steep gradients or excessively narrow or low entrances.

Driving

Driving on ascending and descending gradients

WARNING

Risk of accident due to the drive unit switching off!

Driving up and down longer gradients may cause the drive unit to overheat and switch off. The truck will then no longer decelerate when the accelerator pedal is released and will coast.

Driving up and down longer gradients greater than 15% is not permitted due to the minimum specified braking values. The climbing capability values given below only apply to overcoming obstacles on the roadway and to short differences in level, e.g. ramps.

- Consult the authorised service centre before driving on long ascending and descending gradients greater than 15%.

CAUTION

Risk of component damage due to reduced ground clearance with a hydraulic battery carrier (variant)!

Trucks fitted with a hydraulic battery carrier (variant) have a reduced ground clearance, and the permitted climbing capability is therefore reduced.

The ground clearance with standard tyres is reduced to 70.5 mm. The maximum wear limit of the tyres may not be reached.

- Check the angle of ramps!

NOTE

The values specified in the "Maximum climbing capability" table can be used only to compare the performance of forklift trucks in the same category. The specified values in no way represent the normal daily operating conditions.

Trucks can theoretically be driven on the ascending and descending gradients in the following table.



Maximum climbing capability

Model	Type	Maximum climbing capability [%]		
		With load	Without load	With battery carrier
RX60-35/600	6367	16.9	26.8	10.0
RX60-40	6367	15.5	25.9	
RX60-40/600	6368	15.5	25.5	
RX60-45	6328	14.3	24.6	
RX60-45/600	6369	14.3	24.1	
RX60-50	6329	13.2	23.4	
RX60-50/600	6330	12.6	21.4	

The ascending and descending gradients must not exceed the gradients listed above and must have a rough surface.

Smooth and gradual transitions at the top and bottom of the gradient should prevent the load from falling to the ground or the truck being damaged.

Warning in the event that components protrude beyond the truck contour

Trucks are often required to drive through very narrow or very low spaces such as aisles or containers. The dimensions of the trucks are designed for this purpose. However, movable components may protrude beyond the truck contour and be damaged or torn off. Examples of these components are:

- An unfolded roof panel in the driver's cab
- Open cab doors

Condition of the roadways

Roadways must be sufficiently firm, level and free from dirt and fallen objects.

Drainage channels, level crossings and similar obstacles must be evened out and, if necessary, ramps must be provided so that trucks can drive over these obstacles with as few bumps as possible.

Note the load capacity of manhole covers, drain covers etc.



4

Operation

Driving

There must be sufficient distance between the highest points of the truck or the load and the fixed elements of the surrounding area. The height is based on the overall height of the lift mast and the dimensions of the load; see the chapter entitled "Technical data".

Rules for roadways and the working area

It is only permitted to drive on routes authorised for traffic by the operating company or its representatives. Traffic routes must be free of obstacles. The load may only be set down and stored in the designated locations. The operating company and its representatives must ensure that unauthorised third parties do not enter the working area.

NOTE

Please note the definition of "operating company" in the sense of responsible persons!

Hazard areas

Hazard areas on the roadways must be marked by standard traffic signs or, if necessary, by additional warning signs.

Setting the drive programs

The driving and braking characteristics of the drive can be set on the display and operating unit.

Operation

4

Driving

- Press the drive program button (1) repeatedly until the number of the desired drive program appears on the display (2).

Drive programs 1–5 are available.

Essentially, the higher the drive program number is, the greater the driving dynamics.

The following drive programs are available:

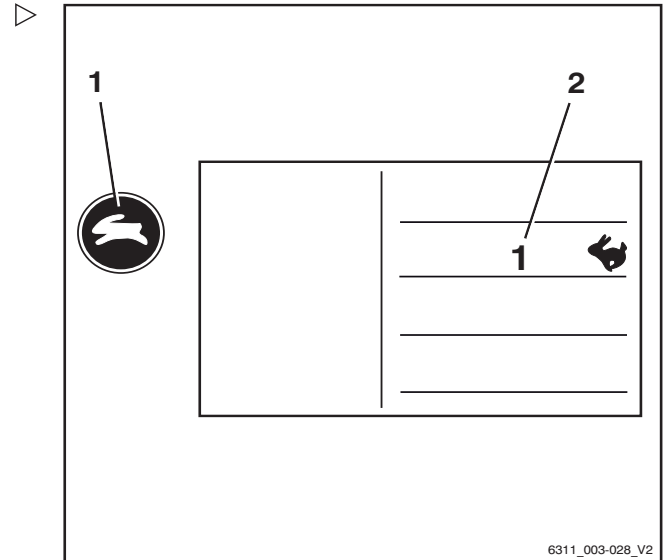

Drive program	1	2	3	4	5
Speed (km/h)	16	16	16	16	16
Acceleration (%) (forwards/backwards)	80	90	100	110	120
Deceleration (%) (forwards/backwards)	80	90	100	110	120
Reversing (%) (forwards/backwards)	80	90	100	110	120
Brake retardation (%) (electric brake booster)	60	70	80	90	100

i NOTE

For trucks with "sprint mode" (variant), switching on sprint mode leads to a general increase in performance.

4 Operation

Driving

Sprint mode (variant)

Switching on sprint mode

The performance of the electric drive can be increased by switching on sprint mode. When sprint mode is on, the truck accelerates to maximum speed more quickly.

i NOTE

With sprint mode switched on, the truck's energy consumption is higher. The battery is therefore discharged more quickly.

- Push button (1).

Sprint mode is switched on, the symbol has a dark background.

i NOTE

Sprint mode remains on until the seat is vacated or button (1) is pushed again.

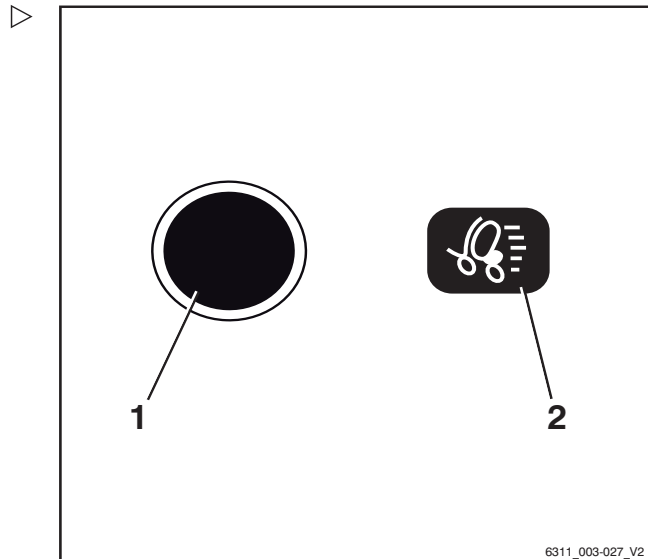

Switching off sprint mode

- Push button (1).

Sprint mode is switched off, the symbol has a light background.

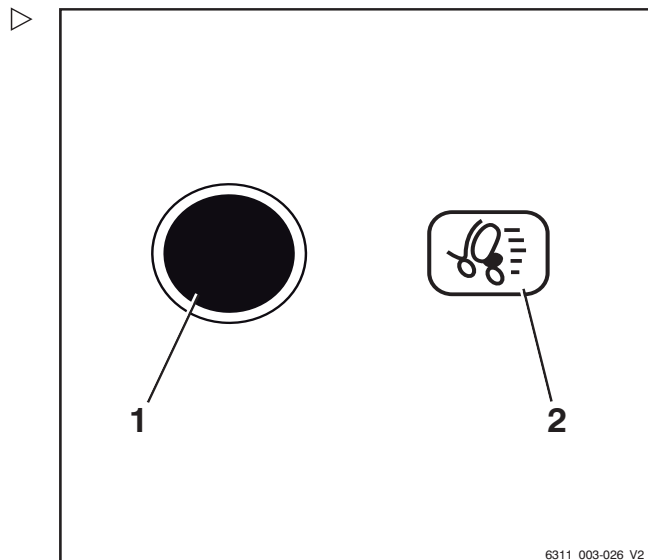

Selecting the drive direction

The desired drive direction of the truck must be selected using the drive direction switch before attempting to drive. Actuation of the drive direction switch depends on which operating devices are fitted on the truck.

Possible equipment variants include:

- Multiple-lever
- Mini-lever
- Joystick 4Plus
- Fingertip
- Mini-console

NOTE

The drive direction can also be changed during travel. Your foot can remain on the accelerator pedal while doing so. The truck decelerates and is then accelerated again in the opposite direction (reversing).

The indicator for the selected drive direction ("forwards" (1) or "reverse" (2)) lights up on the display-operating unit.

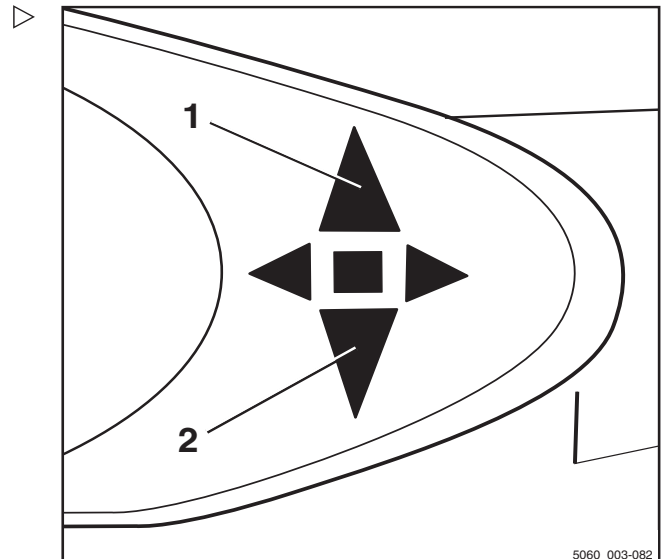

Neutral position

If leaving the truck for a prolonged period, the neutral position must be selected in order to avoid the truck suddenly moving off due to an inadvertent actuation of the accelerator pedal.

- Briefly select the drive direction switch for the direction opposite to the current drive direction.

The drive direction indicator on the display and operating unit goes out.

NOTE

When leaving the seat, the selected drive direction is set to the "neutral position". To drive, the drive direction switch must be actuated again.

4 Operation

Driving

Actuating the drive direction switch, multiple-lever version ▷

i NOTE

Before actuating the drive direction switch, see the notes about choosing the drive direction; see ⇒ Chapter "Selecting the drive direction", P. 4-133.

- For the "forwards" drive direction, push the drive direction switch (1) downwards
- For the "backwards" drive direction, push the drive direction switch upwards

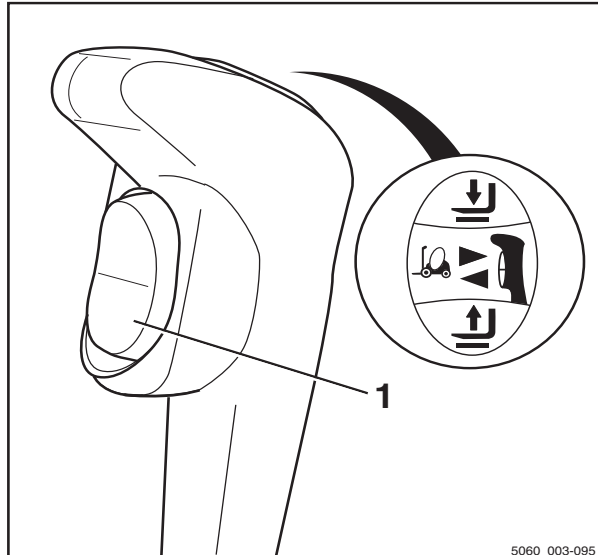

Actuating the drive direction switch, mini-lever version ▷

- Push the cross lever (1) forwards to drive "forward".
- Pull the cross lever backwards to drive "backward".

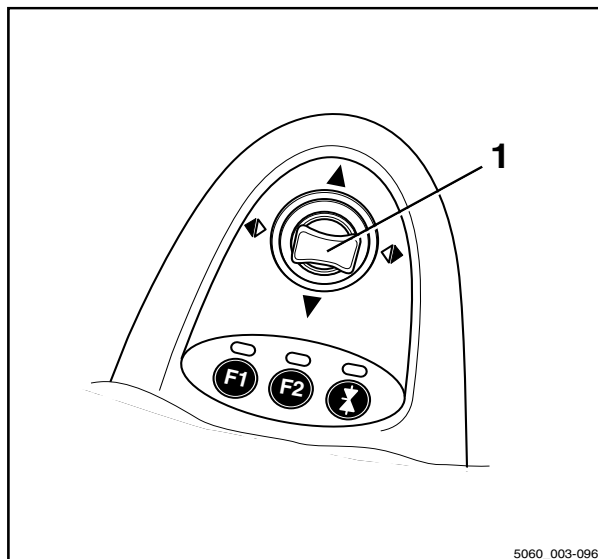

Actuating the vertical rocker switch for the "drive direction", joystick 4Plus version

- For the "forwards" drive direction, push the vertical rocker button for the "drive direction"(1) upwards (A).
- For the "reverse" drive direction, push the vertical rocker button for the "drive direction"(1) downwards (B).

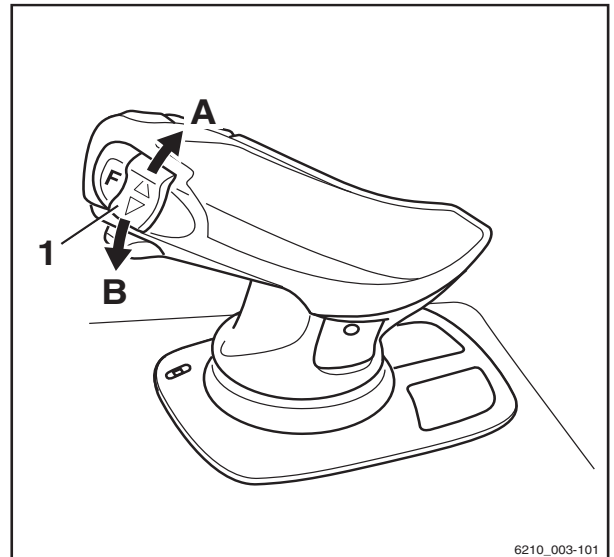

6210_003-101

Actuate the drive direction switch, fingertip version

- For the "forwards" drive direction, push the drive direction switch (1) forwards.
- For the "backwards" drive direction, push the drive direction switch backwards.

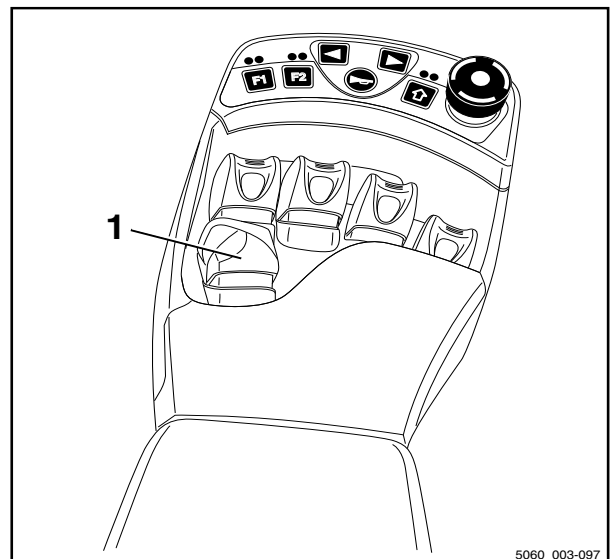

5060_003-097

4 Operation

Driving

Actuating the drive direction switch, mini-console version

- For the "forwards" drive direction, push the drive direction switch (1) forwards.
- For the "backwards" drive direction, push the drive direction switch to the rear.

i NOTE

Alternatively, the drive direction can also be selected using the drive direction switches on the operating devices.

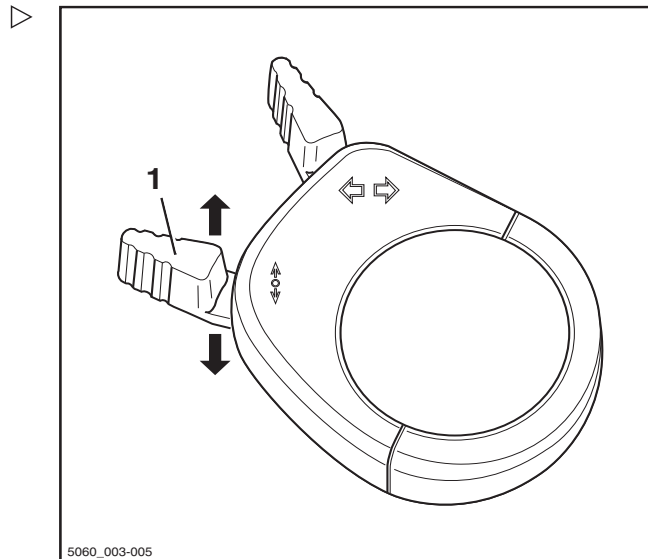

Starting drive mode

⚠ DANGER

Being trapped under a rolling or tipping truck could cause fatal injuries!

- Sit down on the driver's seat.
- Fasten the seat belt.
- Activate the available restraint systems.

Observe the information in the chapter entitled "Safety regulations when driving".

The driver's seat is equipped with a seat switch. This checks whether the driver's seat is occupied. If it is not occupied or in the case of malfunction of the seat switch, the truck cannot be moved and all lift functions are locked out. In such a case, the message SEAT SWITCH appears in the operating unit display; see the chapter entitled "SEAT SWITCH message".

- Lift the fork carriage until the necessary ground clearance is achieved.
- Tilt the lift mast backwards.
- Release the parking brake.
- Select the desired drive direction.

Operation

4

Driving

The indicator for the selected drive direction ("forwards" (1) or "backwards" (2)) lights up on the display and operating unit.

i NOTE

Depending on the equipment, an acoustic signal (variant) may sound a warning during reverse travel, the warning light (variant) may light up or the hazard warning system (variant) may flash.

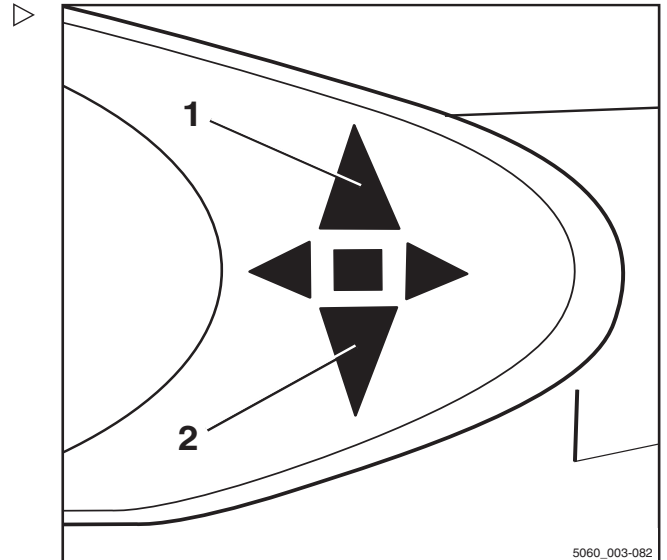

- Actuate the accelerator pedal (3).

The truck will travel in the selected drive direction. The speed is controlled by the accelerator pedal position. When the accelerator pedal is released, the truck decelerates.

i NOTE

The truck can briefly be stopped on upward or downward gradients without actuating the parking brake (electric brake). The truck begins to creep downwards slowly.

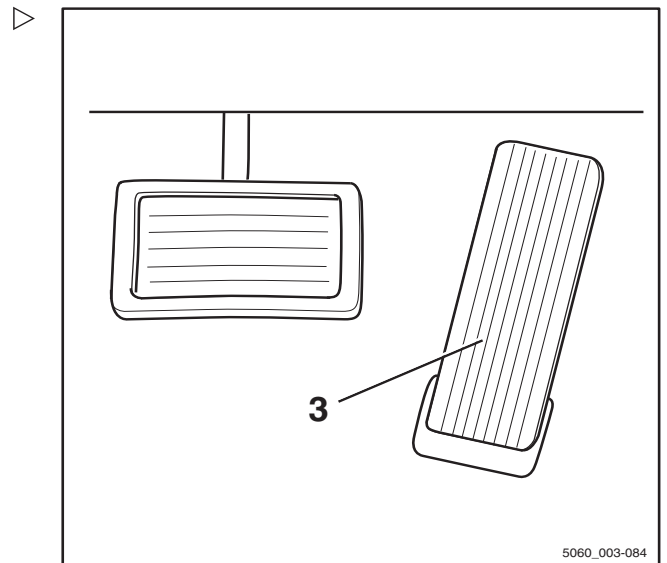

⚠ DANGER

Risk of accident due to brake failure!

The electric brake only functions while the key switch is switched on, the emergency off switch has not been actuated and the parking brake is released.

- Use the brake pedal if the electric brake malfunctions.
- Do not leave the truck without applying the parking brake!

Changing the drive direction

- Remove foot from accelerator pedal.
- Select the desired drive direction.
- Actuate the accelerator pedal.

The truck will travel in the selected drive direction.

4

Operation

Driving

i NOTE

The drive direction can also be changed during travel. Your foot can remain on the accelerator pedal while doing so. The truck decelerates and is then accelerated again in the opposite direction (reversing).

i NOTE

In the event of an electrical fault with the accelerator the drive unit is shut down. The electrical brake (service brake) causes the truck to decelerate. The truck cannot be driven again until the accelerator pedal has been released and then actuated again, provided the electrical fault has been corrected. If the truck still cannot be operated, park it securely and contact your authorised service centre.

Starting drive mode, dual-pedal version (variant)

⚠ DANGER

Being trapped under a rolling or tipping truck could cause fatal injuries.

- Sit down on the driver's seat.
- Fasten the seat belt.
- Activate the available restraint systems.

Observe the information in the chapter entitled Safety regulations when driving.

The driver's seat is equipped with a seat switch. This checks whether the driver's seat is occupied. If it is not occupied or in the case of malfunction of the seat switch, the truck cannot be moved and all lifting functions are locked. In this situation, the message SEAT SWITCH appears on the operating unit display.

- Lift the fork carriage until the necessary ground clearance is achieved.
- Tilt the lift mast backwards.
- Release the parking brake.

Operation

4

Driving

- Press the right accelerator pedal (1) to drive "forwards" and press the left accelerator pedal (2) to drive "backwards".

NOTE

In the dual pedal version, any drive direction switches on the operating devices will not function.

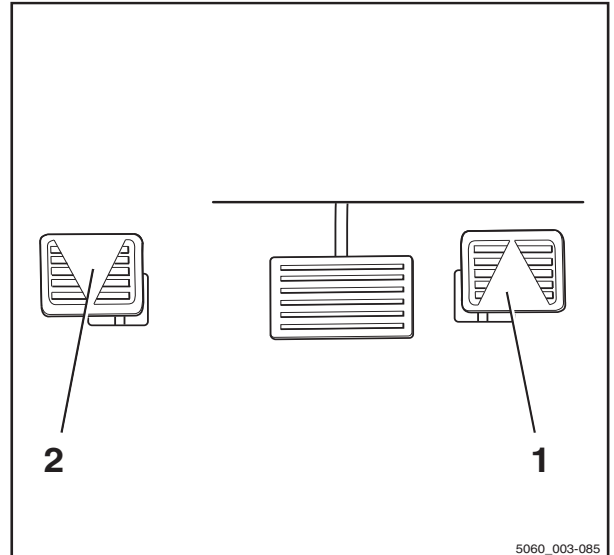

The indicator for the selected drive direction ("forwards" (3) or "backwards" (4)) lights up on the display and operating unit.

NOTE

Depending on the equipment, an acoustic signal (variant) may sound a warning during reverse travel, the warning light (variant) may light up or the hazard warning system (variant) may flash.

The truck will travel in the selected drive direction. The speed is controlled by the accelerator pedal position. When the accelerator pedal is released, the truck decelerates.

NOTE

The truck can be stopped briefly on upward or downward gradients without actuating the parking brake (electric brake). The truck will then begin to creep downhill slowly.

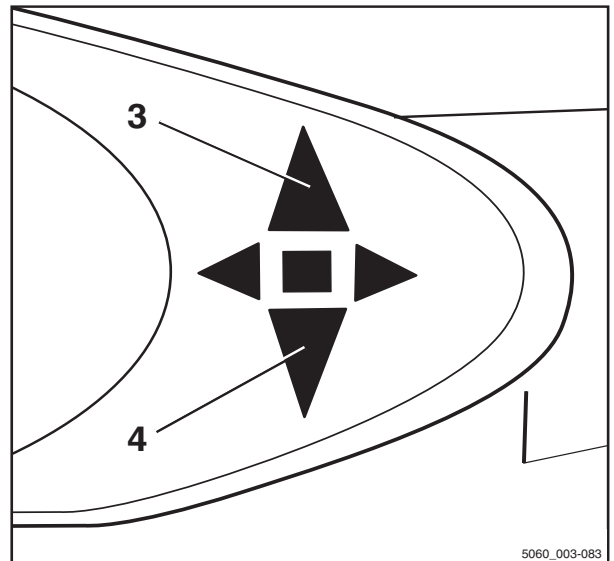

4 Operation

Driving

DANGER

Risk of accident due to brake failure!

The electric brake only functions while the key switch is switched on, the emergency off switch has not been actuated and the parking brake is released.

- Use the brake pedal if the electric brake malfunctions.
- Do not leave the truck without applying the parking brake!

Changing the drive direction

- Remove foot from actuated accelerator pedal.
- Actuate the accelerator pedal for the opposite direction.

The truck will travel in the selected drive direction.

NOTE

In the event of an electrical fault with the accelerator the drive unit is shut down. The electric brake (service brake) causes the truck to decelerate. The truck cannot be driven again until the accelerator pedal has been released and then actuated again, provided that the electrical fault has been corrected. If the truck still cannot be operated, park it securely and contact your authorised service centre.

Operating the service brake

The electric brake converts the acceleration energy of the truck into electrical energy. This causes the truck to decelerate.

Electrical braking recovers energy for the battery. This results in a longer operating time between charging operations and less wear to the brakes.

The truck can also be braked with the mechanical brake by actuating the brake pedal (2). In the first section of the brake pedal's travel, only the electric brake takes effect. As the pedal is depressed further, the mechanical brake is also activated and acts on the drive wheels

⚠ DANGER

If the service brake fails, the truck cannot brake sufficiently. There is a risk of accident!

If the driver notices that the electrical braking effect has reduced by 50% and that the drive torque has decreased to 50% of the normal level, a component failure may have occurred.

- Bring the truck to a standstill using the brakes. Use the parking brake if necessary to assist in this process.
- Notify the authorised service centre.
- Do not operate the truck again until the service brake has been repaired.

⚠ DANGER

At speeds that are too high, there is a danger that the truck could slip or overturn!

The braking distance of the truck depends on the weather conditions and the level of contamination on the roadway. Note that the basic braking distance increases with the square of the speed.

- Adapt your driving and braking style to suit the weather conditions and the level of contamination on the roadway.
 - Always choose a driving speed that will provide a sufficient stopping distance.
-
- Brake the truck by releasing the accelerator pedal (1).
 - If the braking effect is inadequate, use the brake pedal (2) as well to apply the mechanical brake.

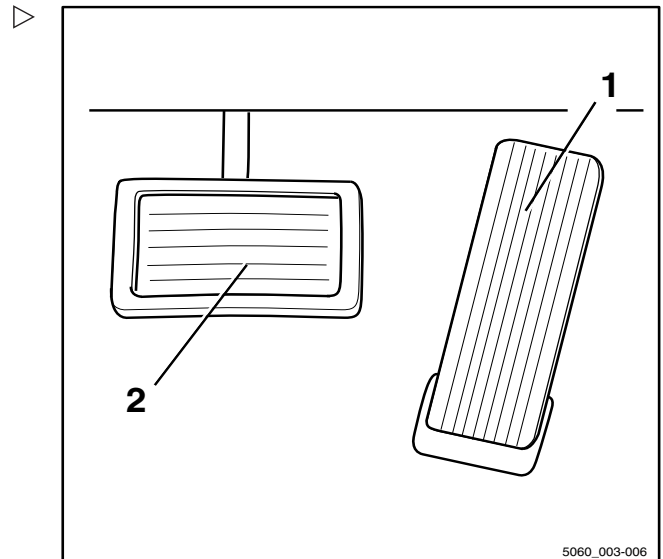

Driving

Parking brake

Operation of the parking brake depends on which parking brake the truck is fitted with.

Possible equipment variants are as follows:

- Mechanical parking brake; see ⇒ Chapter "Actuating the mechanical parking brake", P. 4-142
- Electric parking brake; see ⇒ Chapter "Actuate the electric parking brake", P. 4-144

Actuating the mechanical parking brake

DANGER

There is a risk of being run over if the truck rolls away, and therefore a danger to life.

- The truck must not be parked on a slope.
- In emergencies, secure with wedges on the side facing downhill.
- Only leave the truck when the parking brake is applied.

NOTE

Once the parking brake is released, the previously selected drive direction is retained and is shown on the drive direction indicator.

NOTE

If you operate the accelerator pedal while the parking brake is applied and a drive direction is selected, the message PARKING BRAKE appears in the display.

Operation

4

Driving

Apply the parking brake

- Pull the parking brake lever (1) down fully and release.

The parking brake lever swivels back half the distance into the middle position automatically.

The parking brake is engaged and the wheels are blocked. Driving is no longer possible. The drive direction indicator (2) on the display and operating unit goes out.

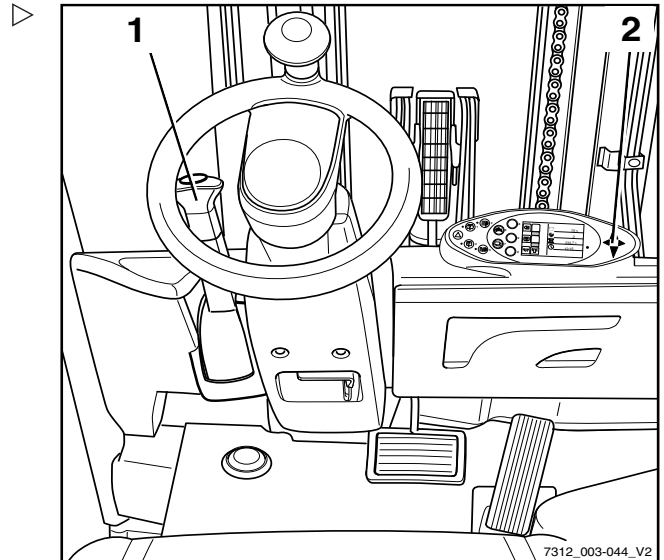

Releasing the parking brake

- Pull the parking brake lever (1) down fully out of the middle position.
- In the lower lever position, pull out the lever knob and then guide the parking brake lever up fully.

i NOTE

The parking brake lever swivels to the upper position automatically by means of spring force and should be guided only lightly by hand. If the adjustment is stiff, notify the authorised service centre.

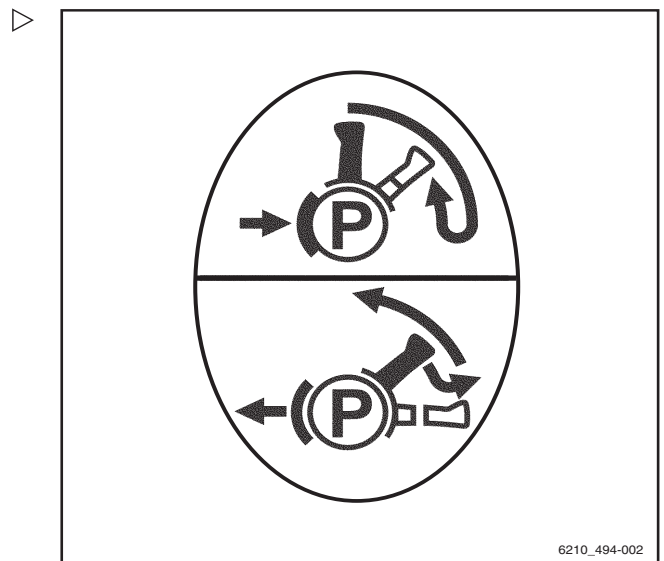

4 Operation

Driving

Actuate the electric parking brake

The electric parking brake is intended for working cycles that require the driver to leave the truck frequently. The parking brake does not need to be applied or released manually. Despite these automatic aids, the driver is always responsible for parking the truck safely. The safety information about parking the truck safely applies.

⚠ DANGER

There is a risk of fatal injury from being run over if the truck rolls away.

- Do not park the truck on gradients.
- Use wedges to secure the truck on the downhill-facing side.
- Only leave the truck when the parking brake is applied.

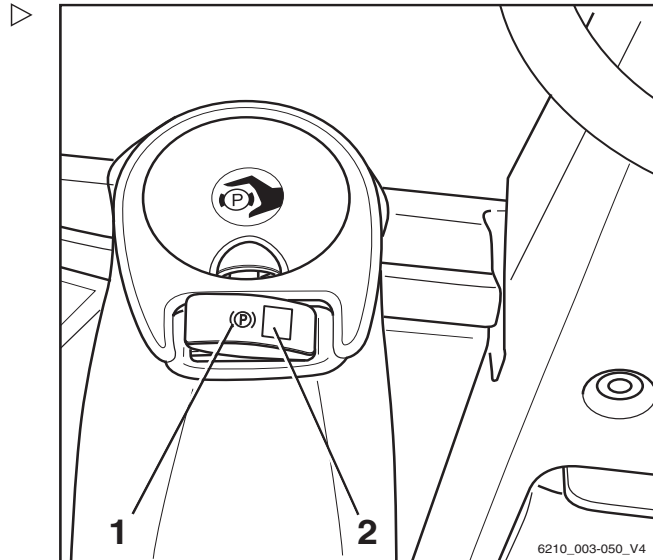

i NOTE

The electric parking brake can be activated or released only if the battery male connector has been connected and the key switch is switched on. The LED(2.) lights up as soon as the truck is switched on. Only the display-operating unit indicates that the parking brake is applied.

- Stop the truck.

As soon as the driver leaves the seat, the seat switch is released and the parking brake is applied. The LED (2) in the push button for the parking brake lights up continuously.

The electric parking brake is applied automatically in the following situations:

Cause	Effect
When the driver leaves the driver's seat:	After a short waiting period, you will hear the parking brake engage and the LED (2) illuminates with a steady light.
When the driver takes his foot off the accelerator pedal:	After a short waiting period, you will hear the parking brake engage and the LED (2) illuminates with a steady light. The truck is held by the traction motor on a gradient until the parking brake is applied.

Cause	Effect
When the key switch is turned off:	You will hear the parking brake engage immediately and the LED (2) illuminates briefly with a steady light until the control units switch off.
If the emergency off switch is actuated, following the emergency off function:	The parking brake is applied.

If the electric parking brake has been applied, the PARKING BRAKE ACTIVE message appears on the display for five seconds. ▷

i NOTE

In order to protect the brake cable for the parking brake, the parking brake is not always fully applied. However under the following circumstances the parking brake is always fully applied:

- *The truck is stationary on a slope and can roll away easily. The parking brake is automatically applied fully*
 - *The driver wishes to fully apply parking brake and does so by pressing the push button for the parking brake*
 - *The driver switches off the truck via the key switch*
- To release the parking brake again, the driver must sit down on the driver's seat.
 - Select the desired drive direction.
 - Press the accelerator pedal.

The parking brake audibly releases and the LED (2) in the push button for the parking brake goes out.



4 Operation

Driving

If the parking brake has not been applied by the accelerator pedal being released or the driver's seat being vacated, then it is not possible to drive the truck until the parking brake has been released by pressing the button. The **RELEASE PARKING BRAKE** message appears in the display.

Releasing the electric parking brake after the truck has been switched on.

i NOTE

The LED(2.) lights up as soon as the truck is switched on. Only the display-operating unit indicates that the parking brake is applied.

The parking brake **cannot** be released by pressing the accelerator pedal immediately after switching on the truck.

- Press the push button (1) to release the electric parking brake.

The parking brake is then released as normal during operation by pressing the accelerator pedal.

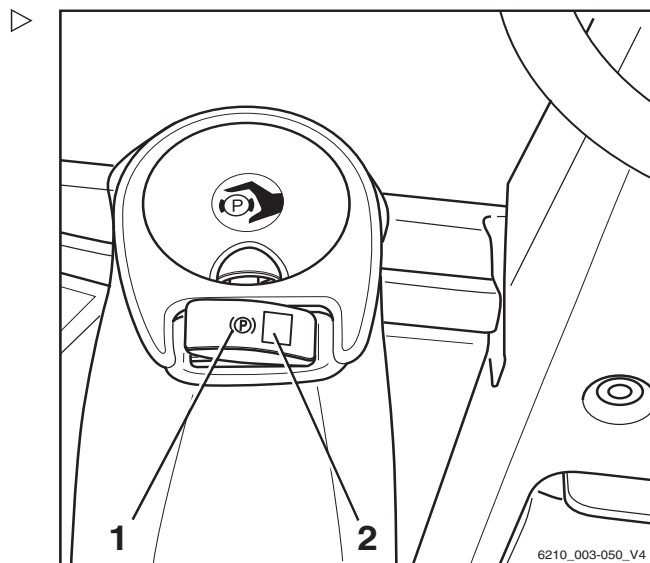
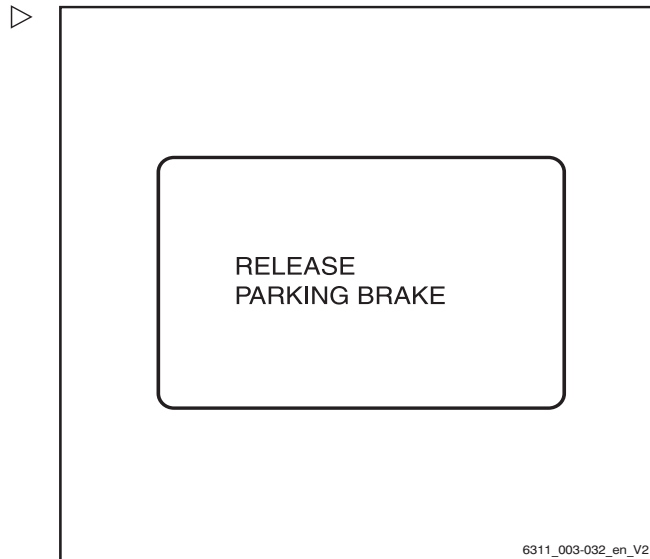

Actuating the parking brake when the truck is stationary

Applying the parking brake manually

- Press the push button (1).

The parking brake will make a noise when it is applied and the LED (2) lights up continuously.

The parking brake is applied automatically

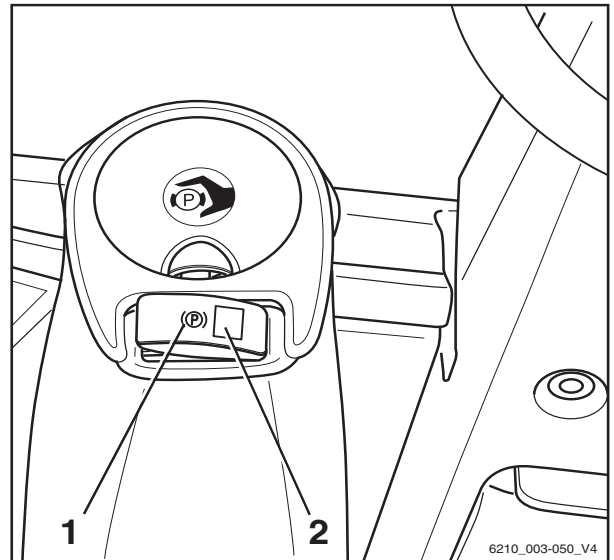

If the electric parking brake is applied, the PARKING BRAKE ACTIVE message appears in the display for 5 seconds.

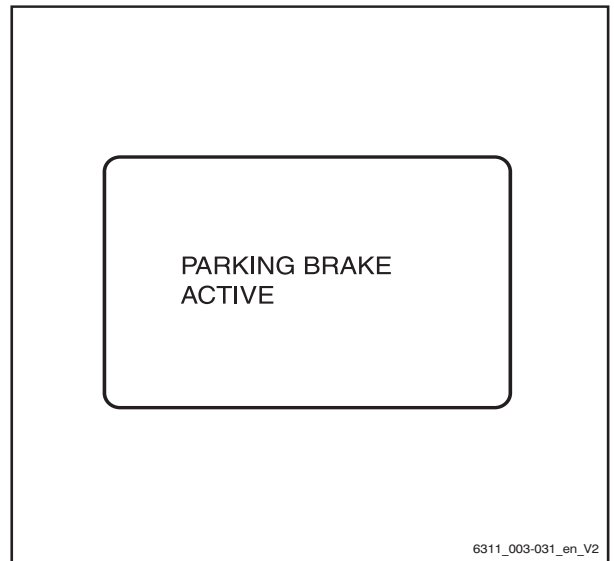

4 Operation
Driving

Releasing the parking brake manually

i NOTE

When the truck is ready for operation, the electric parking brake can be released at any time by pressing the button.

- Sit down on the driver's seat.
- Press the push button (1).

You will hear the parking brake being released and the LED (2) goes out.

i NOTE

Release of the electric parking brake by starting to drive is only available if the electric parking brake is applied automatically by the driver taking his foot off the accelerator pedal or vacating the driver's seat.

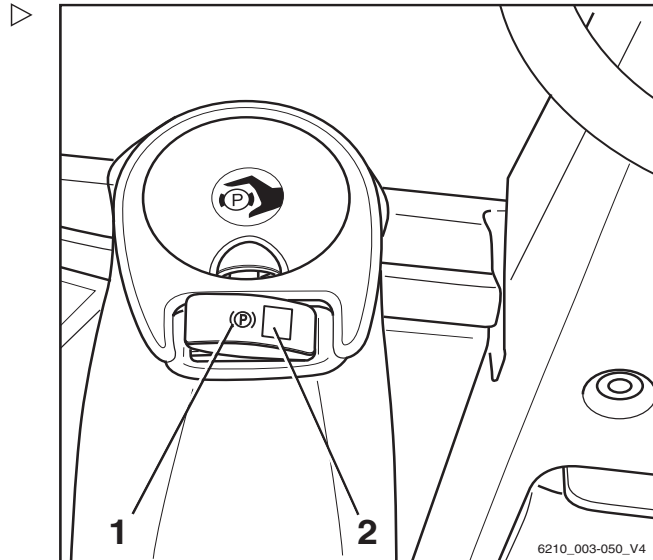

Functions when the truck is moving

Actuation by the driver

- Press the push button (1).

The truck is braked moderately. Depending on the situation, driving is possible again after the button has been released. If the truck is at a standstill, you will hear the parking brake engage and the LED (2) illuminates with a steady light.

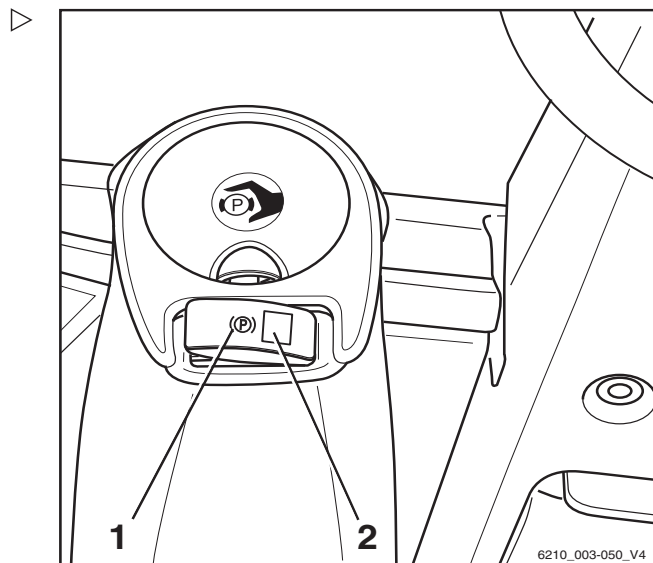

Actuation triggered automatically

Cause	Effect
When the driver leaves the driver's seat:	After a short wait, the truck rolls to a stop or decelerates moderately. If the truck is at a standstill, the parking brake audibly engages and the LED (2) illuminates with a steady light.
When the key switch is turned off:	The truck will roll to a stop. If the truck is at a standstill, you will hear the parking brake engage and the LED (2) illuminates with a steady light until the control units switch off.

Cause	Effect
If the emergency off switch is actuated, following the emergency off function:	The truck will roll to a stop. If the truck is at a standstill, you will hear the parking brake engage and the LED (2) illuminates briefly with a steady light.
Automatic braking:	With the drive deactivated and the seat not occupied or the truck being accelerated heavily, the parking brake is applied with moderate braking force.

"Safe parking" function

The "safe parking" function alerts the driver if he/she leaves the driver's seat or tries to switch off the truck without applying the parking brake. This function also prevents the truck from being switched off when the parking brake is not applied.

The function is activated if the parking brake has been applied but has not been applied correctly as a result of a malfunction.

In both cases the function intervenes as follows:

The function intervenes as follows:

- If the driver tries to switch off the truck when the parking brake is not applied or the parking brake is faulty, the **PARKING BRAKE : APPLY HANDBRAKE !** message appears on the display-operating unit.
- If the driver now leaves the truck without applying the parking brake, a continuous warning sound will also be emitted. The warning sound will stop if the driver returns to his/her position in the truck or if the driver applies the parking brake.
- If the parking brake cannot be applied, the truck also cannot be switched off without taking other measures.

4 Operation

Driving

DANGER

Risk of fatal injury from being run over if the truck rolls away!

If the parking brake is faulty, the truck must be parked safely and secured so that it cannot roll away. To do this, strictly adhere to the following instructions:

- Apply the parking brake manually. See the section entitled "Emergency operation of the electric parking brake".
- If necessary, use wheel chocks to prevent the truck from rolling away.
- Have the parking brake repaired by an authorised service centre.

NOTE

If it is necessary to switch off a truck with a faulty parking brake, the "Switching off a truck with a faulty electrical parking brake" section must be observed. It is essential to secure the truck to prevent it from rolling away.

Malfunctions in the electric parking brake

Before leaving the truck, the driver must make sure that the electric parking brake is applied properly.

If the controller detects a malfunction in the electric parking brake, the truck cannot be switched off.

Possible malfunctions

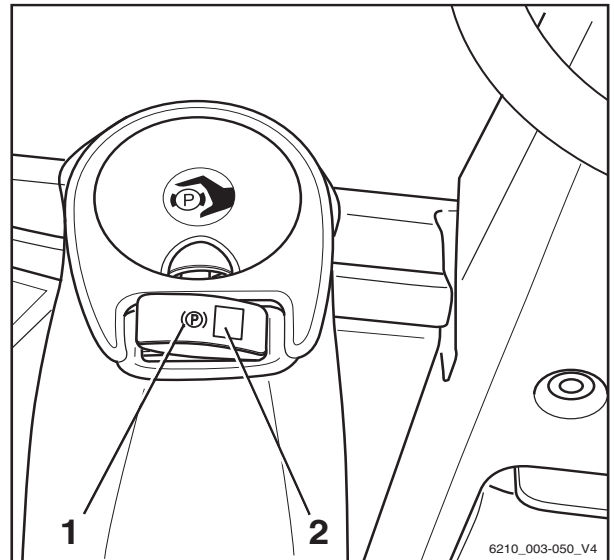

Error indication	Effect	Remedy
LED (2) in the push button (1) flashes.	Parking brake malfunction. It cannot be guaranteed that the parking brake has been applied properly. It may still be possible to actuate the parking brake by pressing the push button (1).	Park the truck safely. Notify the authorised service centre.
LED (2) in push button (1) does not light up when the brake is actuated.	It cannot be guaranteed that the parking brake has been applied properly.	Park the truck safely. Notify the authorised service centre.
The actuation noise is clearly different to the normal noise or there is no noise at all.	It cannot be guaranteed that the parking brake has been applied properly.	Park the truck safely. Notify the authorised service centre.
A warning signal is issued from signal horn or another acoustic warning unit in the truck.	It cannot be guaranteed that the parking brake has been applied properly.	Park the truck safely. Notify the authorised service centre.
The truck rolls even though the parking brake has been applied.	It cannot be guaranteed that the parking brake has been applied properly.	Park the truck safely. Notify the authorised service centre.
Display and operating unit: Symbol: "Parking brake" Display: APPLY HAND-BRAKE !	LED flashes. Parking brake is not applied automatically.	Press and hold the push button (1) for five seconds and then release the push button. The parking brake will make a noise when it is applied.



4

Operation

Driving

Error indication	Effect	Remedy
<p>Display and operating unit: Symbol: "Parking brake malfunction" Display: PARKING BRAKE Error number: X6511</p>	<p>The LED (2) in the push button (1) flashes. The parking brake fails to release. The drive unit is locked. The error message flashes every 30 seconds for five seconds.</p>	<p>Try again to release the parking brake via the push button (1). If this solution does not work, park the truck safely and notify the service centre. If the truck needs to be moved because it is in the way, release the parking brake manually. See the chapter entitled "Emergency operation of the electric parking brake". Then park the truck safely in a different location and notify the service centre.</p>
<p>Display and operating unit: Symbol: "Parking brake malfunction" Display: PARKING BRAKE Error number: X6512</p>	<p>The LED (2) in the push button (1) flashes. The parking brake is not applied. The maximum speed is limited to 5 km/h. The error message flashes every 30 seconds for five seconds.</p>	<p>Try again to apply the parking brake via the push button (1). If this solution does not work, park the truck safely and notify the authorised service centre. Apply the parking brake manually. See the chapter entitled "Emergency operation of the electric parking brake".</p>
<p>Symbol: "Service required" Display: PARKING BRAKE Error number: X6501</p>	<p>The LED (2) in the push button (1) flashes. Maintenance time reached. The error message flashes every 30 seconds for five seconds.</p>	<p>Park the truck safely. Notify the authorised service centre.</p>
<p>Display and operating unit: Symbol: "Parking brake malfunction" Display: PARKING BRAKE Error number: X6520</p>	<p>Control problem The drive unit remains active as long as the contactor is closed. The error message flashes every 30 seconds for five seconds.</p>	<p>Try again to apply the parking brake via the push button (1). If this solution does not work, park the truck safely and notify the service centre. Apply the parking brake manually if necessary. See the chapter entitled "Emergency operation of the electric parking brake".</p>

Error indication	Effect	Remedy
Display and operating unit: Symbol: "Temperature" Display: PARKING BRAKE Error number: X6502	Application of the parking brake is delayed. The system switches off in the event of over-temperature. The error message flashes every 30 seconds for five seconds.	Allow the parking brake to cool down. If the warning appears again, notify the authorised service centre
Display and operating unit: Symbol: "Parking brake malfunction" Display: PARKING BRAKE Error number: X6510	Malfunction in the parking brake. The drive unit remains active as long as the contactor is closed. Creep mode is possible once the parking brake has been released. The error message flashes every 30 seconds for five seconds.	Try again to apply the parking brake via the push button (1). If this solution does not work, park the truck safely and notify the authorised service centre. Apply the parking brake manually if necessary. See the chapter entitled "Emergency operation of the electric parking brake".

Actuating a faulty electric parking brake

If the electric parking brake is faulty, the LED (2) in the push button (1) will flash and the message APPLY HANDBRAKE! will appear on the display and operating unit. A possible cause of the malfunction is that the parking brake cannot determine whether the truck is stationary or still in motion. The brake can be then be applied via the push button (1). The following section describes how to actuate the parking brake when it is faulty:

Actuating a faulty parking brake when the truck is stationary

Apply the parking brake:

- Press and hold the push button (1) for at least five seconds and then release the push button.

The parking brake will make a noise when it is applied. After the push button is released, the parking brake will not make any further noise; if you hear the parking brake release again it means that the push button was pressed for less than five seconds. In this case, press the push button again to apply the parking brake again. Repeat this process up to four times if necessary.

Releasing the parking brake:

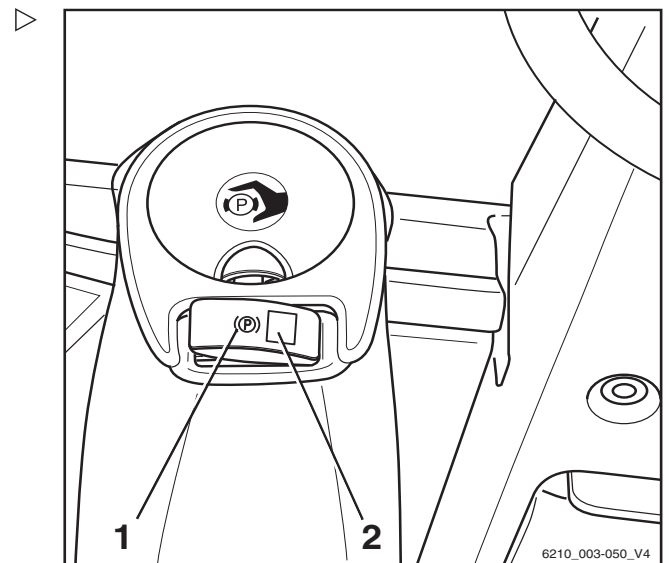

4 Operation

Driving

- Press the push button (1) then release the push button.

The parking brake will make a noise when it is released. If the malfunction in the parking brake persists, it will not be possible to release the parking brake.

Actuating a faulty parking brake when the truck is in motion

- Press push button.

The parking brake is applied.

i NOTE

The truck will brake more sharply if the push button (1) is pressed and held for a long period or if the push button is pressed multiple times.

Switching off the truck when the electric parking brake is faulty

If the electric parking brake cannot be applied and the driver tries to switch off the truck, the truck will not switch off at first. Instead, the truck responds with the following error messages:

The red lamp (1) in the multifunction display begins to flash.

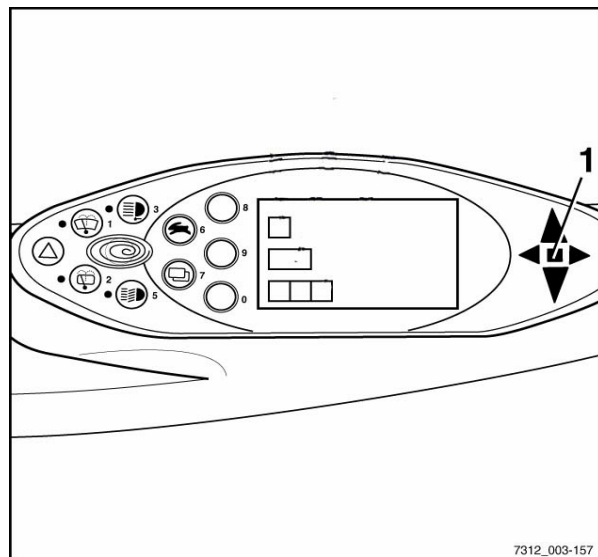

7312_003-157

Operation

4

Driving

The LED (2) in the push button for the electric parking brake flashes. ▷

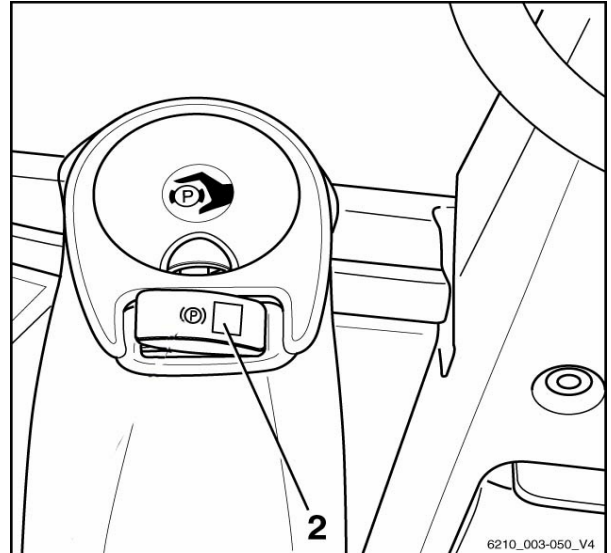

The message PARKING BRAKE APPLY HANDBRAKE ! appears on the display and operating unit. ▷



If the driver now leaves the truck, a warning sound will be emitted and will stop only when the driver has resumed his/her seat in the truck. To switch off the truck despite the parking brake being faulty (e.g. in order to tow the truck) proceed as follows:

- Switch off the key switch again.

The message APPLY HANDBRAKE ! will appear on the display and operating unit.

- Press the **ESC** (3) soft key.

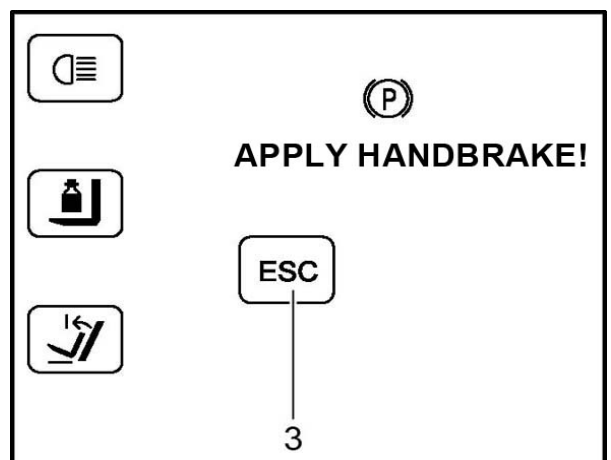

4 Operation

Driving

- The message SWITCH OFF TRUCK? will appear on the display and operating unit. To continue switching off the truck, press the soft key (4). To abort the process for switching off the truck, press the ESC (5) soft key.

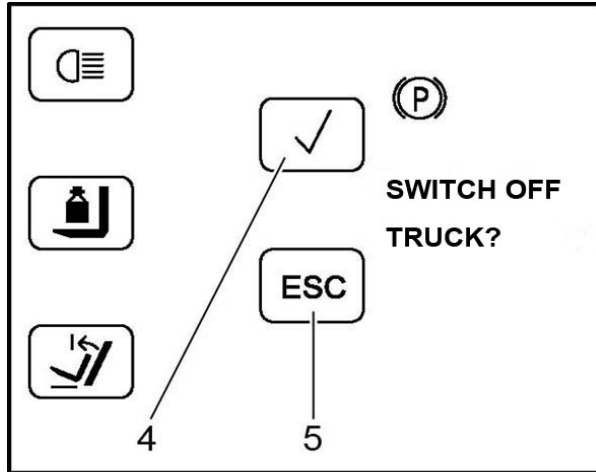

- The message ARE YOU SURE? appears on the display and operating unit. To continue switching off the truck, press the soft key (6). The truck will now switch off. To abort the process for switching off the truck, press the ESC (7) soft key.

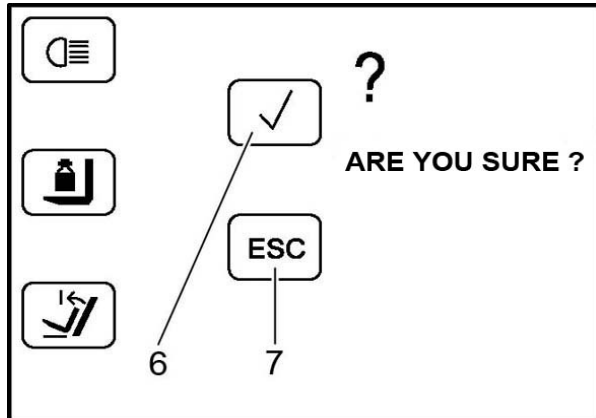

If switching off the truck was continued, the truck will now be switched off and the parking brake will not have been applied. The truck can now be towed. If the truck is not going to be towed, the truck must be secured with wheel chocks to prevent it from rolling away.

⚠ DANGER

Risk of fatal injury from the truck rolling away!

The truck is not secured against rolling away because the parking brake is not applied.

- Use wheel chocks to prevent the truck from rolling away.
- Notify the authorised service centre so that it can repair the parking brake.

Steering

⚠ DANGER

If the hydraulics fail, there is a risk of accident as the steering characteristics have changed.

- Do not operate the truck if it has a defective steering system.
-
- Steer the truck by turning the steering wheel (1) accordingly.

Turning the steering wheel in the direction of arrow (A) steers the truck in drive direction (A).

Turning the steering wheel in the direction of arrow (B) steers the truck in drive direction (B).

For turning radius information, see ⇒ Chapter "Technical data", P. 419.

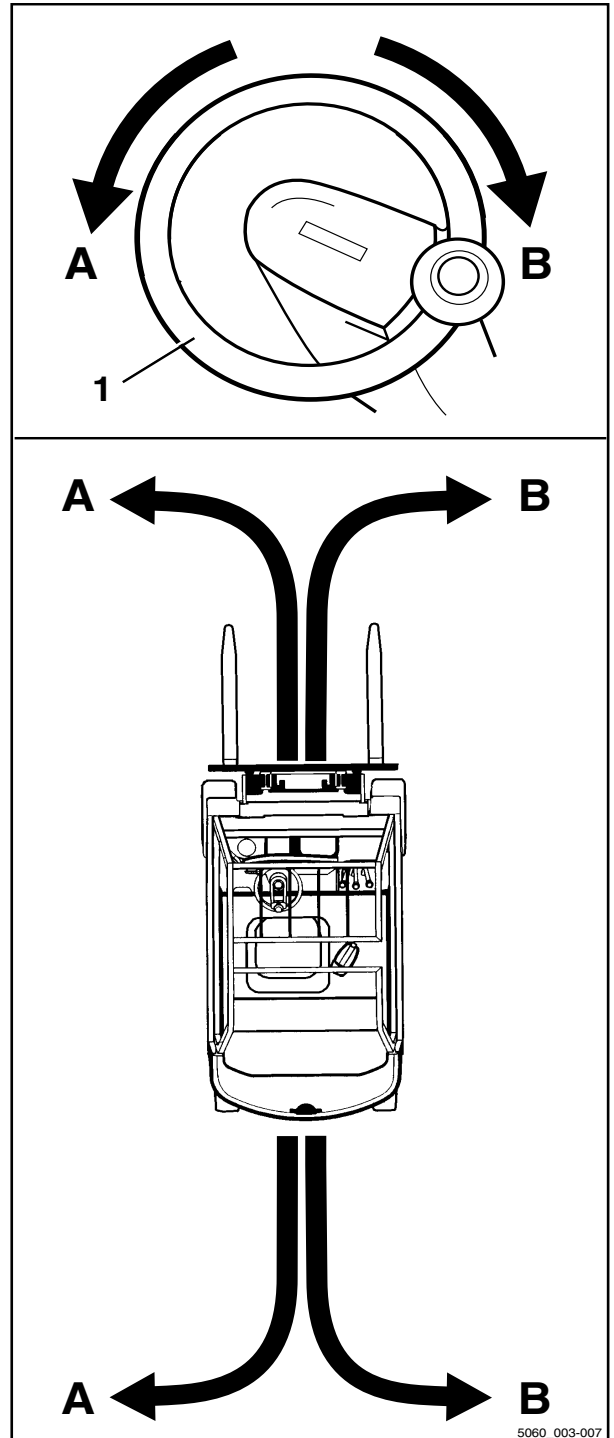

4

Operation

Driving

Reducing speed when turning (Curve Speed Control)

This function reduces the speed of the truck as the steering angle increases, regardless of the amount to which the accelerator has been actuated. If the steering angle is reduced again upon exiting the curve, the truck accelerates in line with how far the accelerator is depressed.

However, the function does not release the driver from the duty to approach a curve at a speed according to the following factors:

- The carried load
- The roadway conditions
- The radius of the curve

⚠ DANGER

The Curve Speed Control function cannot override the physical limits of stability. Despite this function, there still is a risk of tipping!

- Before using this function, familiarise yourself with the change to the driving and steering characteristics of the truck.

⚠ DANGER

Increased risk of tipping if the Curve Speed Control function is disabled! If the controller fails while the truck is in motion or if the controller is disabled, the truck will no longer automatically brake when steering.

- Do not turn off the key switch while driving.
- Actuate the emergency stop switch only in emergencies.
- Always adapt your driving style to the conditions.

Despite the Curve Speed Control function, the truck may overturn in extreme cases within the following situations:

- Cornering too fast on uneven or inclined roadways.
- Turning the steering wheel sharply while driving.
- Cornering with an inadequately secured load.
- Cornering too fast on a smooth or wet roadway.

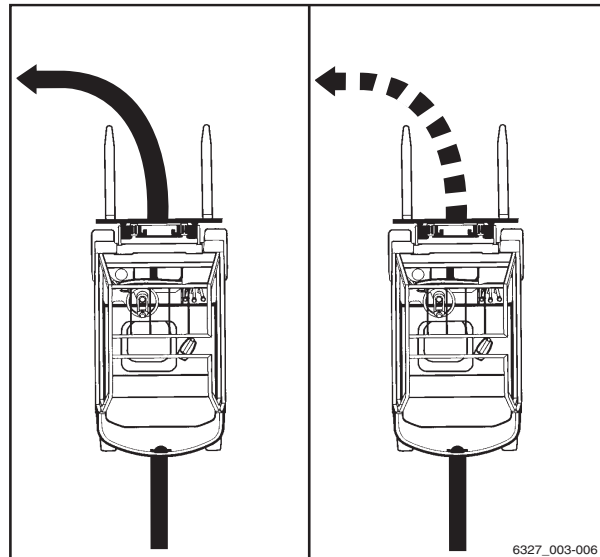

6327_003-006

Reducing speed with a raised load (variant) ▷

This function (variant) reduces the speed of the truck with a raised load.

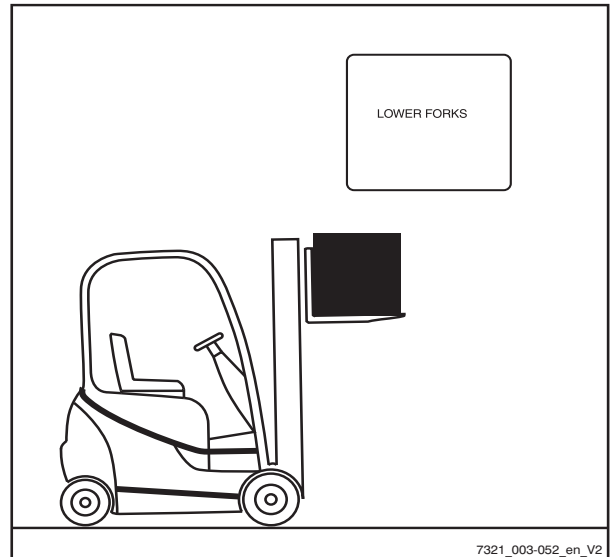

Parking

Parking

Parking the truck securely and switching it off



⚠ DANGER

There is a risk of fatal injury from being run over if the truck rolls away.

- The truck must not be parked on a slope.
- In emergencies, secure with wedges on the side facing downhill.
- Do not leave the truck until the parking brake has been applied.

⚠ DANGER

There is a risk to life caused by a falling load or if truck components are being lowered.

- Lower the load fully before leaving the truck.

⚠ CAUTION

Batteries may freeze!

If the truck is parked in an ambient temperature of below -10°C for an extended period, the batteries will cool down. The electrolyte may freeze and damage the batteries. The truck is then not ready for operation.

- At ambient temperatures of below -10°C, only park the truck for short periods of time.
- Apply parking brake.

Operation

4

Parking

- Lower the fork carriage to the ground.
- Tilt the lift mast forwards until the tips of the fork arms rest on the ground.
- If attachments (variant) are fitted, retract the working cylinders; see the chapter entitled "General instructions for controlling attachments".
- Turn the switch key to the left and remove it.

NOTE

Switch keys, FleetManager cards (variant), FleetManager transponder chips (variant) and the PIN code for access authorisation (variant) must not be handed over to other persons unless explicit instructions to this effect have been given.



5060_003-130

Wheel chock (variant)

The wheel chock (variant) is used to prevent the truck from rolling away on a slope.

- Lift handle (2) on the support mounting.
- Remove wheel chock (1) from the support mounting.
- Push the wheel chock under a front axle wheel on the side facing the downhill slope.

NOTE

After use, return the wheel chock to the support mounting and press the handle (2) down again.

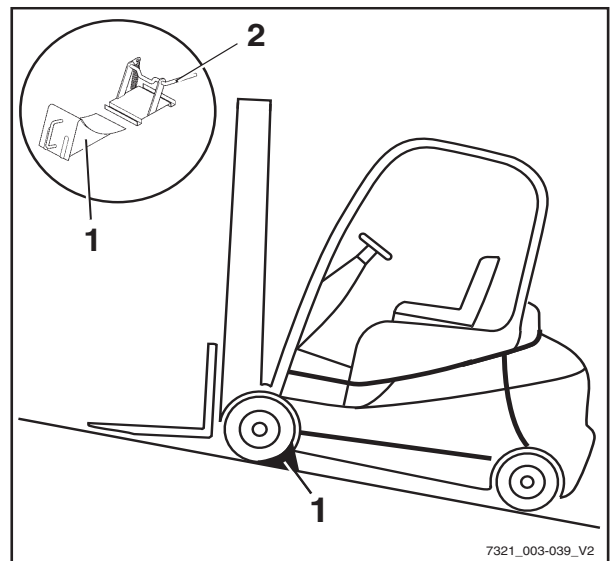

7321_003-039_V2

Lifting

Lifting

Lifting system variants

The movement of the fork carriage and the lift mast heavily depends on the following equipment:

- The lift mast with which the truck is equipped, see ⇒ Chapter "Types of lift mast", P. 4-162
- The operating device with which the hydraulic functions are controlled, see ⇒ Chapter "Lifting system operating devices", P. 4-163

Regardless of the equipment variants of the truck, the basic specifications and procedures must be complied with, see ⇒ Chapter "Safety regulations when handling loads", P. 4-184.

Types of lift mast

One of the following lift masts may be installed in the truck:

Telescopic mast

During lifting, the lift mast rises over the outer lift cylinders, bringing the fork carriage with it via the chains (fork carriage rises twice as fast as the inner lift mast). The top edge (1) of the inner lift mast can therefore be higher than the fork carriage.

⚠ DANGER

Risk of accident due to collision of the lift mast or load with low ceilings or entrances.

- Note that the inner lift mast or load may be higher than the fork carriage.
- Note the heights of ceilings and entrances.

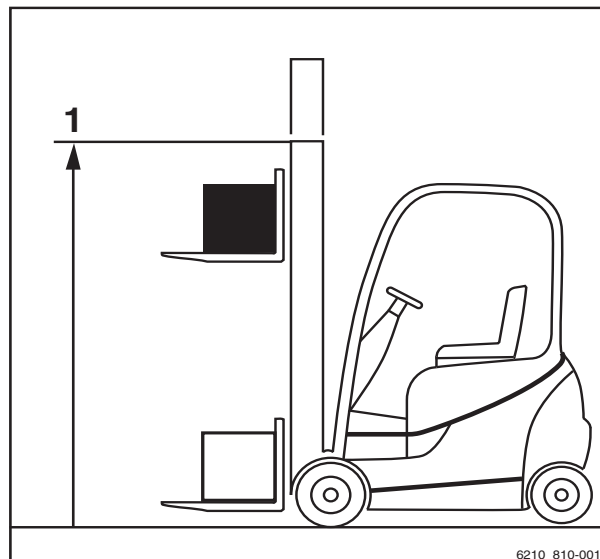

6210_810-001

Triplex lift mast (variant)

During lifting, the inner lift cylinder moves up to free lift (3), and then the outer lift cylinders raise the inner lift mast up to the max. height (2).

⚠ DANGER

Risk of accident due to collision of the lift mast or load with low ceilings or entrances.

- Note that the inner lift mast or load may be higher than the fork carriage.
- Note the heights of ceilings and entrances.

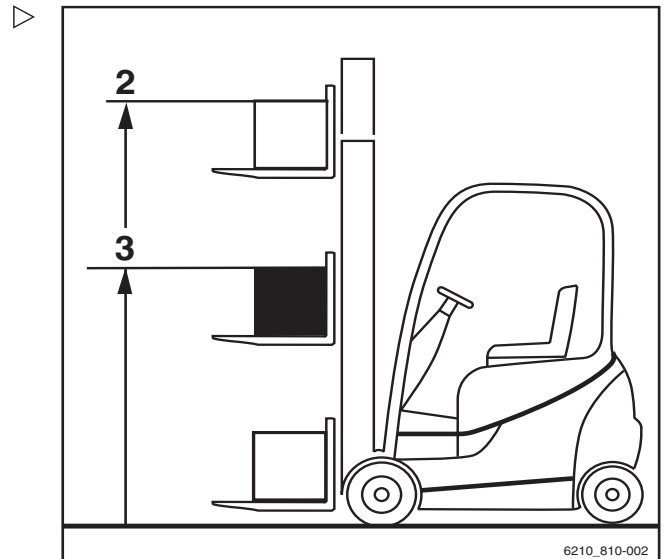

6210_810-002

Lifting system operating devices

The operation of the lifting system depends on the operating devices that are fitted on the truck.

Possible equipment variants include:

- Multiple-lever
 - Double mini-lever
 - Triple mini-lever
 - Quadruple mini-lever
 - Joystick 4Plus
 - Fingertip
- The following information must be observed regardless of the equipment variant:

⚠ DANGER

Reaching into or climbing between moving parts of the truck (e.g. lift mast, sidershifts, working equipment, load carrying devices etc.) can lead to serious injury or death and is therefore prohibited.

- Observe the safety regulations for handling loads.
- Only operate the lifting system from the driver's seat.

4 Operation

Lifting

Multi-lever lifting system

⚠ DANGER

Reaching or climbing between moving parts of the truck (e.g. lift mast, sideshifts, working equipment, load carrying devices etc.) can lead to serious injury or death and is therefore prohibited.

- Always observe the safety regulations for handling loads; see ⇒ Chapter "Safety regulations when handling loads", P. 4-184.
- Only operate the lifting system from the driver's seat.

Lifting/lowering the fork carriage

To lift fork carriage:

- Move the "lift-lower" operating lever (1) in the direction of the arrow (B).

To lower fork carriage:

- Move the "lift-lower" operating lever (1) in the direction of the arrow (A).

Tilting the lift mast

To tilt the lift mast forwards:

- Move the "tilt" operating lever (2) in the direction of the arrow (C).

To tilt the lift mast backwards:

- Move the "tilt" operating lever (2) in the direction of the arrow (D).

i NOTE

The symbols on the operating levers show the direction of movement of the lift mast or fork carriage when the operating lever is moved.

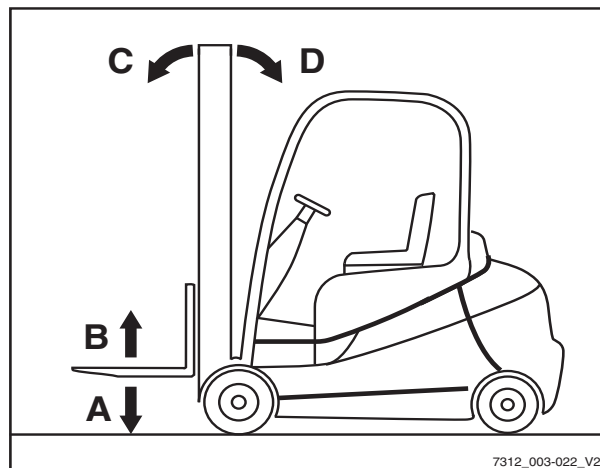
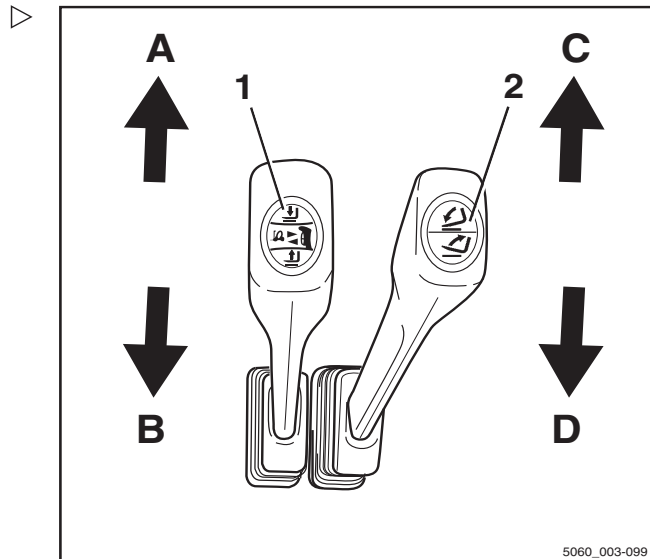

Controlling the lifting system using a double mini-lever

⚠ DANGER

Reaching into or climbing between moving parts of the truck (e.g. lift mast, sideshifts, working equipment, load carrying devices etc.) can lead to serious injury or death and is therefore prohibited.

- Observe the safety regulations for handling loads.
- Only operate the lifting system from the driver's seat.

Lifting/lowering the fork carriage

To lift fork carriage:

- Move the "lift mast" 360° lever (1) in the direction of arrow (B).

To lower fork carriage:

- Move the "lift mast" 360° lever (1) in the direction of arrow (A).

Tilting the lift mast

To tilt the lift mast forwards:

- Move the "lift mast" 360° lever (1) in the direction of arrow (C).

To tilt the lift mast backwards:

- Move the "lift mast" 360° lever (1) in the direction of arrow (D).

i NOTE

The symbols on the 360° lever show the direction of movement of the lift mast and the fork carriage when the 360° lever is moved.

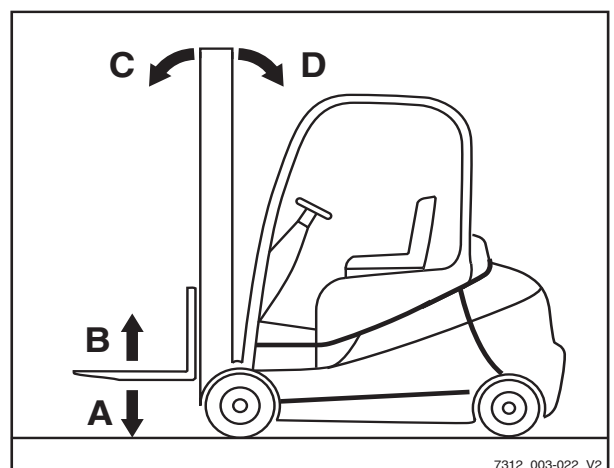
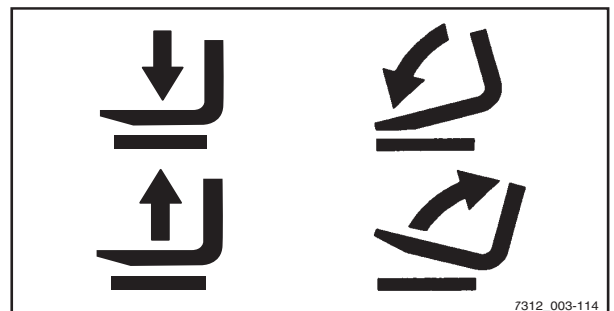
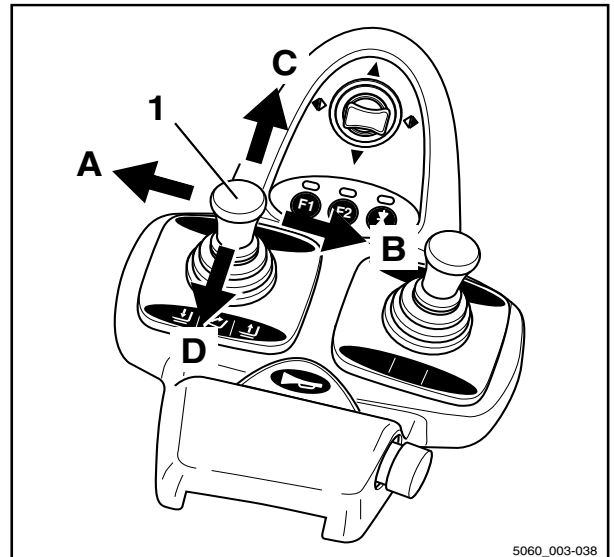

4 Operation
Lifting

Controlling the lifting system using a triple mini-lever ▷

⚠ DANGER

Reaching into or climbing between moving parts of the truck (e.g. lift mast, sideshifts, working equipment, load carrying devices etc.) can lead to serious injury or death and is therefore prohibited.

- Observe the safety regulations for handling loads.
- Only operate the lifting system from the driver's seat.

Lifting/lowering the fork carriage

To lift fork carriage:

- Move the "lift mast" 360° lever (1) in the direction of arrow (B).

To lower fork carriage:

- Move the "lift mast" 360° lever (1) in the direction of arrow (A).

Tilting the lift mast

To tilt the lift mast forwards:

- Move the "lift mast" 360° lever (1) in the direction of arrow (C).

To tilt the lift mast backwards:

- Move the "lift mast" 360° lever (1) in the direction of arrow (D).

i NOTE

The symbols on the 360° lever show the direction of movement of the lift mast and the fork carriage when the 360° lever is moved.

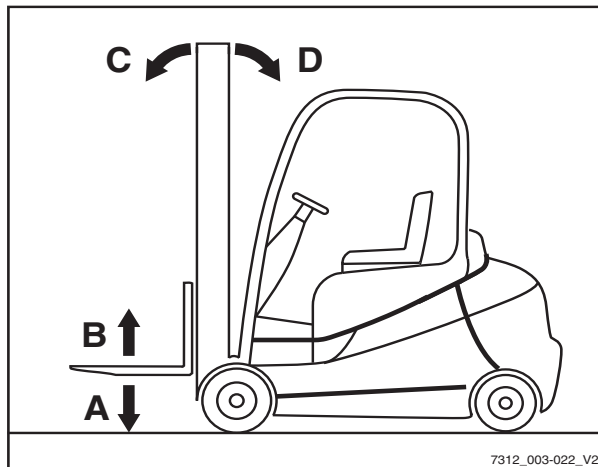
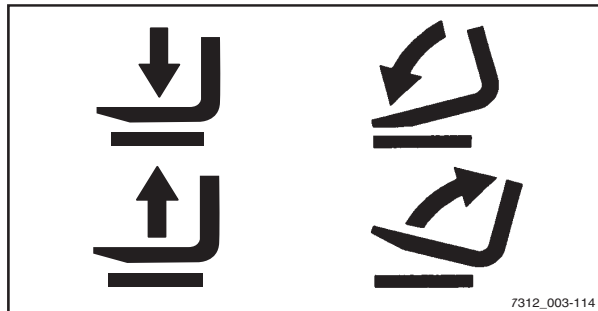
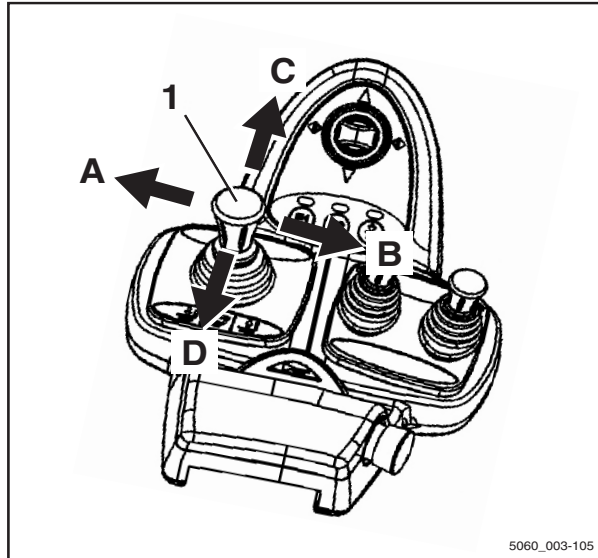

Controlling the lifting system using a quadruple mini-lever

⚠ DANGER

Reaching into or climbing between moving parts of the truck (e.g. lift mast, sidershifts, working equipment, load carrying devices etc.) can lead to serious injury or death and is therefore prohibited.

- Observe the safety regulations for handling loads.
- Only operate the lifting system from the driver's seat.

Tilting the lift mast

To tilt the lift mast forwards:

- Move the "lift mast" operating lever (1) in the direction of the arrow (A).

To tilt the lift mast backwards:

- Move the "lift mast" operating lever (1) in the direction of the arrow (B).

Lifting/lowering the fork carriage

To lift fork carriage:

- Move the "lift-lower" operating lever (2) in the direction of arrow (D).

To lower fork carriage:

- Move the "lift-lower" operating lever (2) in the direction of arrow (C).

i NOTE

The symbols on the operating levers show the direction of movement of the lift mast or fork carriage when the operating lever is moved.

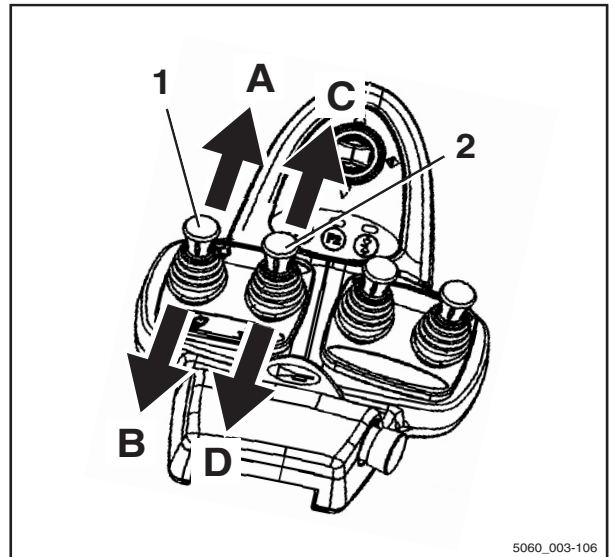

5060_003-106

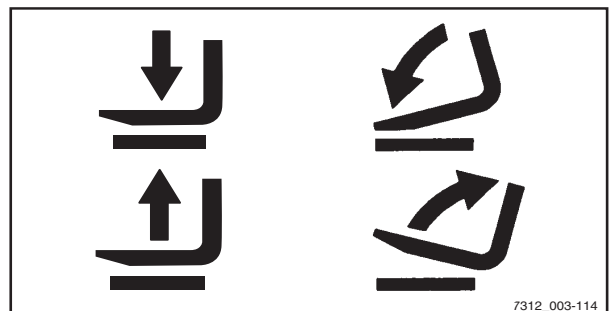

7312_003-114

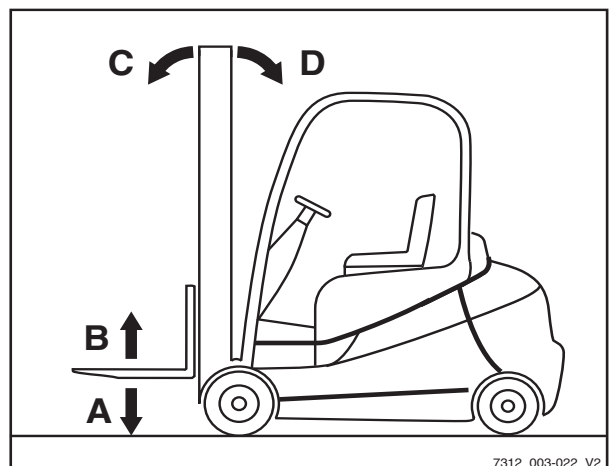

7312_003-022_V2

4

Operation

Lifting

Controlling the lifting system using the joystick 4Plus

⚠ DANGER

Reaching into or climbing between moving parts of the truck (e.g. lift mast, sideshifts, working equipment, load carrying devices etc.) can lead to serious injury or death and is therefore prohibited.

- Observe the safety regulations for handling loads.
- Only operate the lifting system from the driver's seat.

Lifting/lowering the fork carriage

To lift the fork carriage:

- Pull the joystick 4Plus (1) backwards (B).

To lower the fork carriage:

- Push the joystick 4Plus (1) forwards (A).

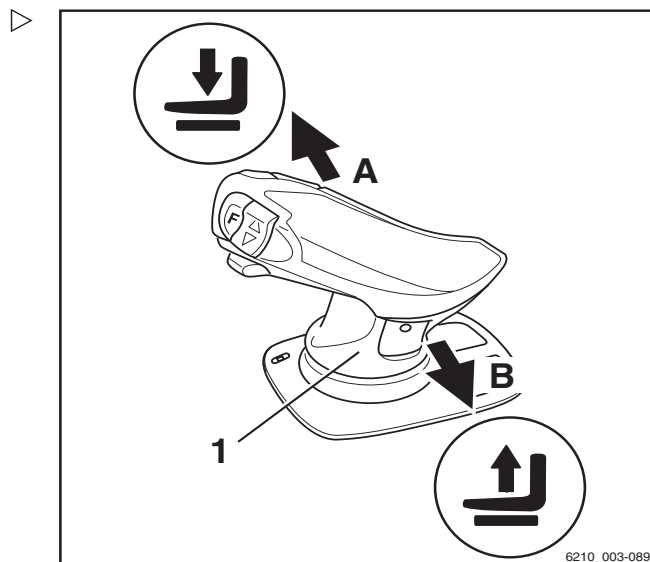

Operation

4

Lifting

Tilting the lift mast

To tilt the lift mast forwards:

- Tilt the horizontal rocker button (2) to the left (C).

To tilt the lift mast backwards:

- Tilt the horizontal rocker button (2) to the right (D).

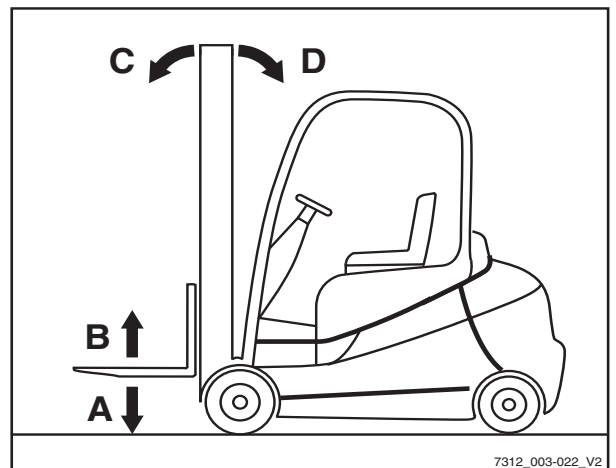
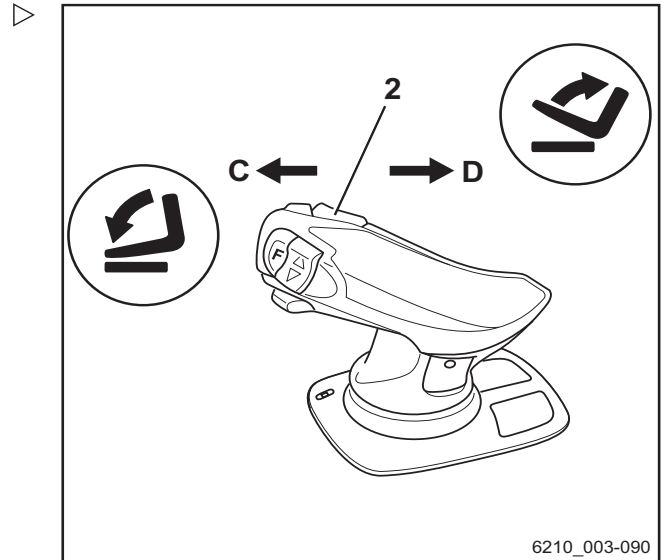

Fork-carriage sideshift

To move the fork carriage to the left.

- Push the joystick 4Plus (1) to the left (E).

To move the fork carriage to the right:

- Push the joystick 4Plus (1) to the right (F).

i NOTE

The symbols on the joystick 4Plus indicate the direction of movement of the lift mast or the fork carriage.

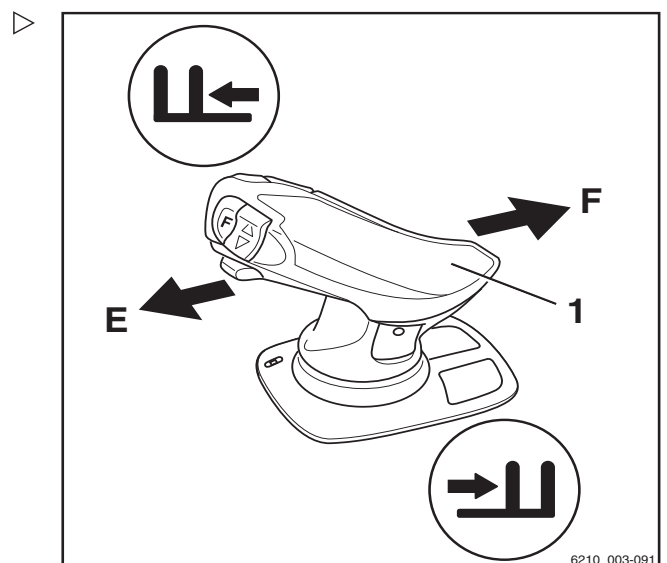

4 Operation

Lifting

Controlling the lifting system with the fingertip console

⚠ DANGER

Reaching into or climbing between moving parts of the truck (e.g. lift mast, sideshifts, working equipment, load carrying devices etc.) can lead to serious injury or death and is therefore prohibited.

- Observe the safety regulations for handling loads.
- Only operate the lifting system from the driver's seat.

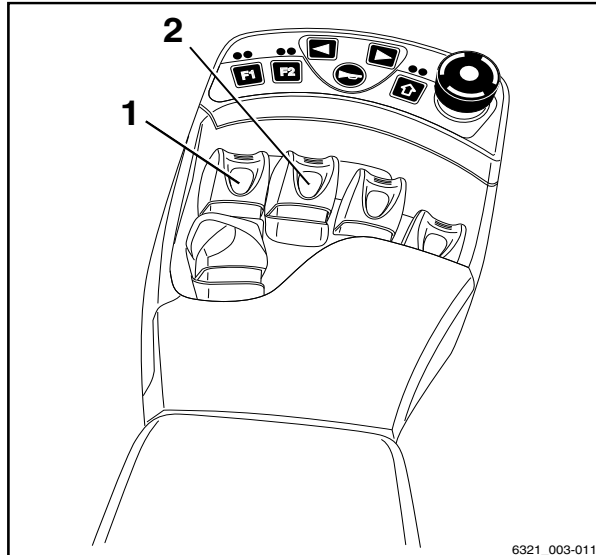

Lifting/lowering the fork carriage

To lift fork carriage:

- Pull the "lift/lower" operating lever (1) backwards.

To lower fork carriage:

- Push the "lift/lower" operating lever (1) forwards.

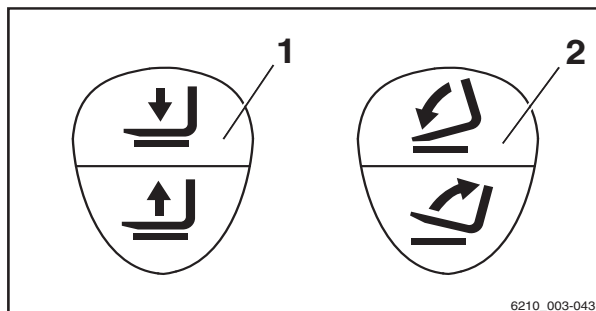

Tilting the lift mast

To tilt the lift mast forwards:

- Push the "tilt" operating lever (2) forwards.

To tilt the lift mast backwards:

- Pull the "tilt" operating lever (2) backwards.

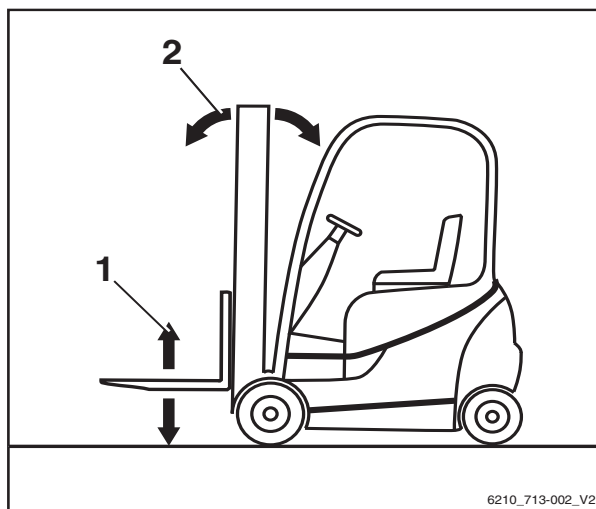

i NOTE

The symbols on the operating levers show the direction of movement of the lift mast or fork carriage when the operating lever is moved.

Changing the fork arms

DANGER

Risk of fatal injury from being run over if the truck rolls away!

- Do not park the truck on a gradient.
- Apply the parking brake.
- Change the fork arms in a separate, safe location on a level surface.

WARNING

There is a risk of injury when changing the fork arms; the weight of the fork arms could cause them to fall on your legs, feet or knees. The space to the left and right of the fork is a danger area.

- Always wear protective gloves and safety footwear when changing the fork arms.
- Ensure that no one stands in the danger area!
- Do not pull on the fork arms.
- The fork arms must always be carried by two people; if necessary, use a hoist.

NOTE

- *For installation and removal, a transport pallet is recommended for supporting the fork arms. The pallet size depends on the fork arm size used and should be dimensioned such that the fork arms do not protrude after being placed on the pallet. This means the fork arms can be safely placed down and transported.*
- *Both fork arms can be pushed over to the same side. It is possible to choose the side via which the forks are removed*

4 Operation
Lifting

Removal

- Select a pallet corresponding to the fork arm size.
- Set down the pallet next to the fork carriage on the side chosen for removal.
- Lift the fork carriage until the fork arms are approx. 3 cm above the pallet.
- Apply the parking brake.
- Remove the switch key.
- Unscrew the locking screw (2) on the side chosen for removal.
- Pull up the locking lever (1) and push the fork arms onto the pallet one after the other.

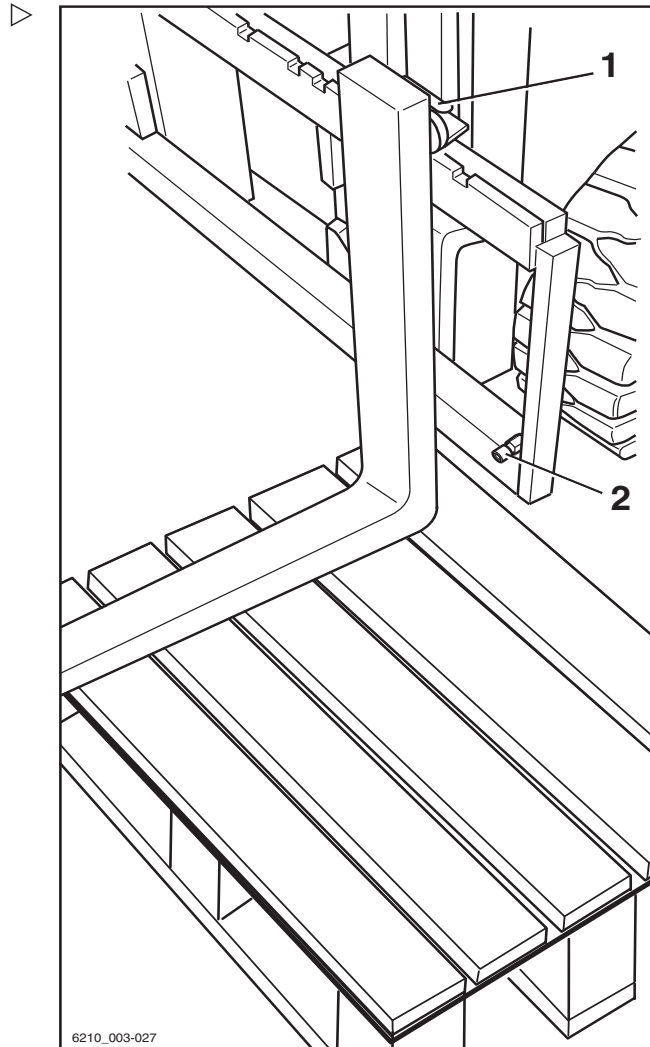

Installation

- Make sure that the locking screw is unscrewed on the side chosen for installation.
- Place the fork arms on a pallet next to the fork carriage on the side chosen for installation.
- Pull up the locking lever (1) and push the fork arms onto the fork carriage one after the other.
- Place the fork arms in the required position and push down the locking lever. Ensure that the locking lever snaps into place.
- Screw in and tighten the locking screw (2).

⚠ DANGER

There is a risk of fatal injury from a falling load or fork!

- Tighten the locking screw each time a fork is changed.
- Driving and moving loads without the locking screw is prohibited.

i NOTE

If the truck is equipped with the "load measurement" comfort feature, a "zero adjustment of the load measurement" must always be performed after the fork arms have been chan-

ged. Otherwise, correct load measurement cannot be guaranteed.

Fork extension (variant)

DANGER

There is a risk of being run over if the truck rolls away and therefore a danger to life.

- Do not park the truck on a slope.
- Apply the parking brake.
- Change the fork extension in a separate, safe location on a level surface.

WARNING

There is a risk of crushing!

The weight of the fork extension can cause crushing or cuts on sharp edges or burrs.

- Always wear protective gloves and safety footwear.

WARNING

There is a risk of tipping!

The weight and dimensions of the fork extension affect the stability of the truck. The permissible weights stated on the capacity rating plate must be reduced in proportion to the actual load distance.

The truck is equipped with a fork extension ex works, the capacity rating plate is already adjusted accordingly.

- Observe load capacity, see the "Before picking up a load" chapter.

NOTE

If the truck is equipped with the "load measurement" comfort feature, a "zero adjustment of the load measurement" must always be performed after the fork extensions have been changed. Otherwise, correct load measurement cannot be guaranteed.

4

Operation

Lifting

Attachment

⚠ DANGER

Risk to life from falling load!

At least 60% of the length of the fork extension must lie on the fork arm. A maximum 40% overhang over the fork arm end is permissible. The fork extension must also be secured against slipping from the fork arm.

If the fork extension (1) is not secured with a securing bolt (2) and lynch pin (3), the load with the fork extension may fall.

- Push the fork extension completely to the back of the fork.
 - Make sure that 60% of the length of the fork extension is on the fork arm.
 - Always secure the fork extension with a securing bolt.
 - Always secure the securing bolt with a lynch pin.
-
- Remove the lynch pin (3) from the securing bolt (2).
 - Remove the securing bolt from the fork extension (1).
 - Push the fork extension onto the fork arms until it is flush with the fork back.
 - Insert the securing bolts located behind the fork back fully into the fork extension.
 - Insert the lynch pin into the securing bolt and secure.

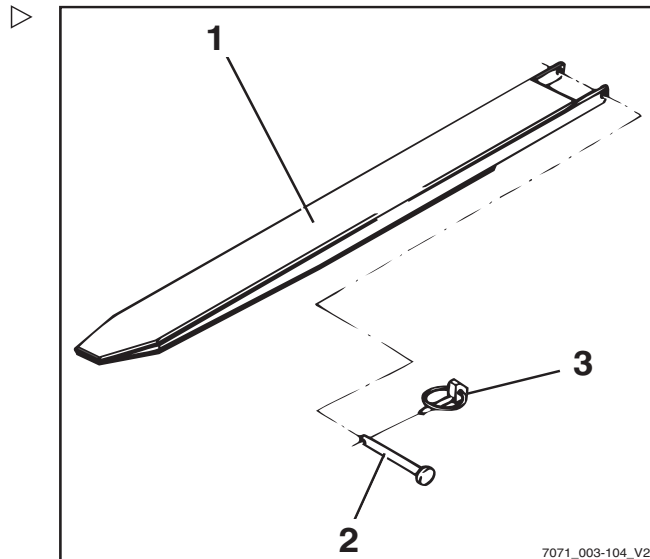

Removal

- Remove the lynch pin (3) from the securing bolt (2).
- Remove the securing bolt from the fork extension (1).
- Pull the fork extension from the fork arms.
- Insert the securing bolt fully into the fork extension.
- Insert the lynch pin into the securing bolt and secure.

Operation with reversible fork arms (variant) ▷

⚠ DANGER

Risk to life from falling load!

Standard fork arms are not structurally designed for reverse operation. If this instruction is not observed, it can lead to material failure and the load falling.

- Only work in reverse operation using reversible fork arms (1)

⚠ WARNING

Risk of accident from slipping load!

Loads may slip on the reversible fork arms if there is no load support. A fork extension (variant) cannot be secured against slipping.

- Do not use a fork extension (variant)

⚠ WARNING

Risk of accident from the truck tipping over.

When driving, the centre of gravity of the load (2) must not be higher than 600 mm above the ground. The truck may tip forwards when driving or braking.

- Only drive with a load centre of gravity up to a max. of 600 mm above the ground

i NOTE

If the truck is equipped with the "load measurement" comfort feature, a "zero adjustment of the load measurement" must always be performed after the reversible fork arms have been changed. Otherwise, correct load measurement cannot be guaranteed.

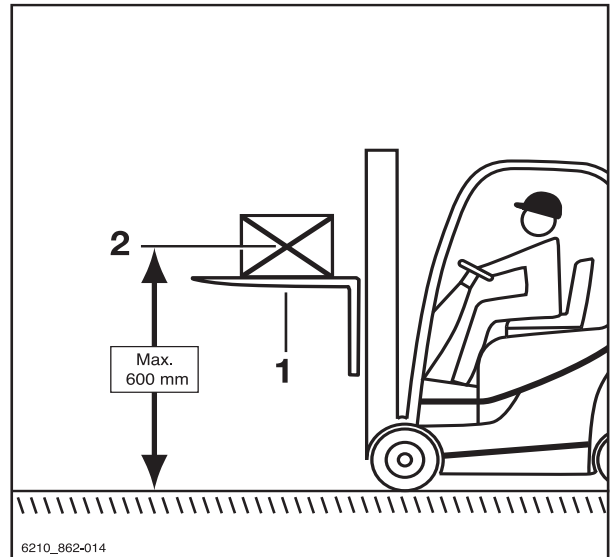

4 Lifting Operation

Reversible fork arms (1) can be used to reach an additional lift height. The reversible fork arms are installed on the fork carriage in the same manner as standard fork arms. Loads may be lifted on and beneath the reversible fork arms. The mast is lifted and tilted in the same manner.

- Only work in reverse operation using reversible fork arms
- Do not use a fork extension (variant)
- If the "load measurement" comfort feature is available, perform a "zero adjustment of the load measurement"
- To drive, raise the load centre of gravity (2) to a max. of 600 mm above the ground
- Observe the information in the section entitled "Transporting suspended loads"

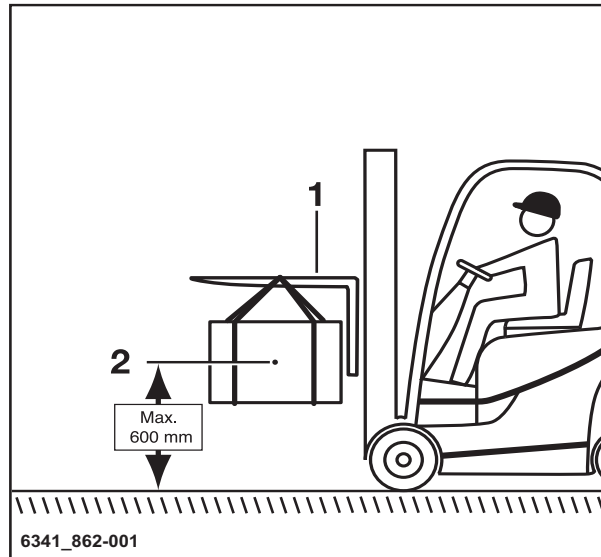

Malfunctions during lifting mode

Incorrect extension sequence

⚠ DANGER

Risk of accidents!

With triple masts (variant), an incorrect extension sequence may occur, i.e. the inner lift mast may extend before the free lift has finished. As a result, the overall height is exceeded and damage may occur in passageways or from low ceilings.

An incorrect extension sequence may, for instance, result from:

- The hydraulic oil temperature being too low.
 - The fork carriage becoming blocked in the inner lift mast.
 - Blocking of the free lift cylinder.
 - The chain roller becoming blocked at the free lift cylinder.
- If the hydraulic oil temperature is too low, slowly actuate the lift mast functions several times in order to raise the oil temperature.

In the event that the fork carriage is blocked in the inner lift mast, or the free lift cylinder or chain roller are blocked, the cause of the blockage must be eliminated before resuming work.

- Notify your service centre

Load chains not under tension

⚠ DANGER

Danger caused by a falling load!

- Make sure that the chain(s) does (do) not become slack when lowering the load.

Slack chains can, for instance, result from:

- Resting the fork carriage or the load on the racking.
- Fork carriage rollers becoming blocked in the lift mast due to contamination.
- If the fork carriage or the load comes to an unexpected stop, lift the fork carriage until the chains are under tension again and lower the load at another suitable location.
- If the fork carriage rollers in the lift mast become blocked due to contamination, lift the fork carriage until the chains are under tension again. Remove the contamination before resuming work.

⚠ WARNING

Risk of injury!

- Observe the safety regulations for working on lift masts; see ⇒ Chapter "Working at the front of the truck", P. 5-374.

Hydraulic blocking function

The hydraulic blocking function ensures that all the functions of the working hydraulics are disabled whenever the seat switch in the driver's seat is unloaded.

If the driver stands up from the driver's seat, the blocking function prevents the hydraulic functions that:

- Lift the load
- Lower the load
- Tilt the lift mast
- Additional functions

Lifting

Releasing the block on the hydraulics

Proceed as follows to release the block on the hydraulics:

- Sit down on the driver's seat.

All the relevant functions of the working hydraulics will be available again.

NOTE

If it is not possible to release the block on the hydraulics when the load is raised because of a technical fault, the load must be lowered using the "emergency lowering" mechanism before any further action is taken. Do not operate the truck again until the fault has been rectified by the authorised service centre.

Automatic lift cut out (variant)

Description:

The automatic lift cut out (variant) means that the load cannot be lifted above a preset height. This function uses a sensor that is welded on at the factory at the required lift mast limit height. Once attached, the height cannot be easily changed.

Application:

- If the ceiling of the building is lower than the maximum lift height of the truck, this variant can prevent the lift mast from accidentally hitting the ceiling, which can result in damage.
- If the truck is frequently used at a particular height, the work is simplified by the automatic lift cut out at this height.

NOTE

If a load is lifted very quickly, the fork carriage and load are moved approximately 15 cm above the position of the sensor due to inertia. This deviation is already taken into consideration at the factory when determining the position of the sensor.

Overriding and reactivating the automatic lift cut out

If a load needs to be lifted to the truck's maximum lift height and the automatic lift cut out function is not required, it is possible to override the lift cut out. It is automatically reactivated when the truck is switched off and back on again.

To override the automatic lift cut out:

- Press Softkey **F1** (1).

Automatic lift cut out is switched off. The **F1** symbol is displayed. Loads can be lifted to the maximum lift height for the truck.

To switch the automatic lift cut out back on:

- Press Softkey **F1** (1).

Automatic lift cut out is switched on. The **F1** symbol is displayed. Loads can be lifted only to the set lift height for the truck.

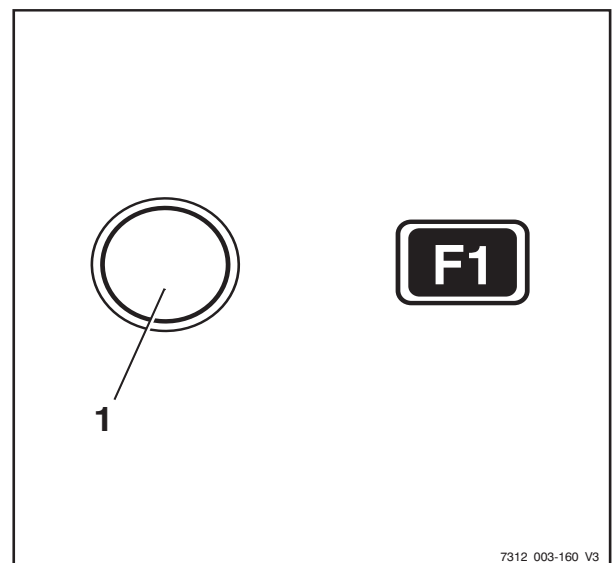

7312_003-160_V3

Lift mast vertical position (variant)

Description

If the truck is equipped with the "lift mast vertical position" comfort feature (variant), the driver can put down goods, such as paper rolls, vertically with precision and thus avoid damage when unloading. The tilt cylinders run into the end stops gently to prevent hard vibrations and impacts. Oscillating motions of the truck are minimised, thus increasing work safety. The lift mast vertical position reduces wear on various components and therefore reduces maintenance costs.

4 Operation
Lifting

⚠ CAUTION

Risk of damage to property due to the lift mast colliding with racks or other objects!

- Before using the "lift mast vertical position" comfort feature, position the truck at a sufficient distance from racks and other objects.

The "lift mast vertical position" comfort feature consists of the following individual functions:

- Display of the "lift mast vertical position"
- Automatic approach towards the "lift mast vertical position"
- Gentle running-in to the end stops

The "lift mast vertical position" comfort feature is only available as a variant if the truck is equipped with one of the following operating devices:

- Double mini-lever (1)
- Triple mini-lever (2)
- Quadruple mini-lever (3)
- Fingertip (4)
- Joystick 4Plus (5)

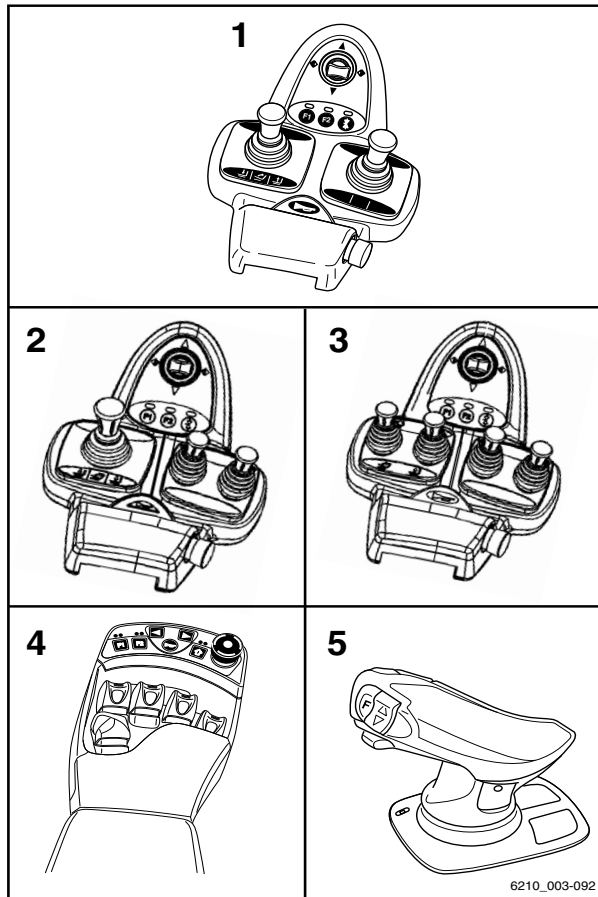

Display of the "lift mast vertical position" ▷

The driver can see the mast tilt on the display and operating unit screen. The bar in the display shows the current mast tilt relative to the "lift mast vertical position". The arrow above the bar marks the vertical position of the lift mast.

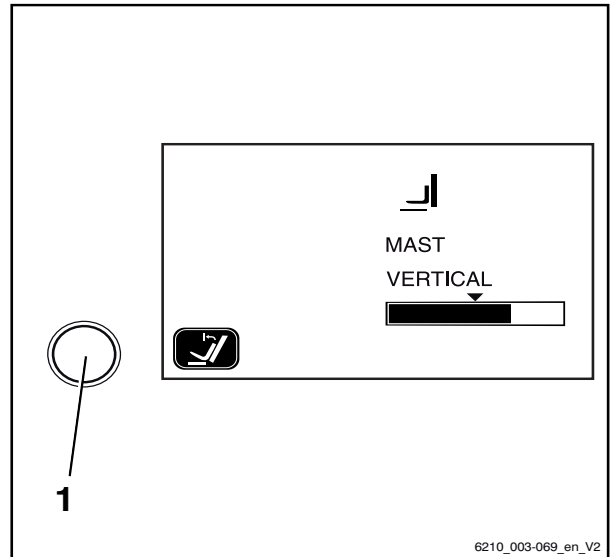

Automatic approach towards the "lift mast vertical position" ▷

- Switch on the "lift mast vertical position" comfort feature via the button (1) on the display and operating unit.
- Tilt the lift mast forwards using the corresponding operating device. The lift mast stops automatically as soon as the preselected setting is reached for the "lift mast vertical position".

If the comfort feature is switched off, the lift mast tilts forwards past the "lift mast vertical position" without stopping.

If the lift mast is tilted backwards, it moves past the "lift mast vertical position" without stopping, regardless of whether the comfort feature is switched on or not.

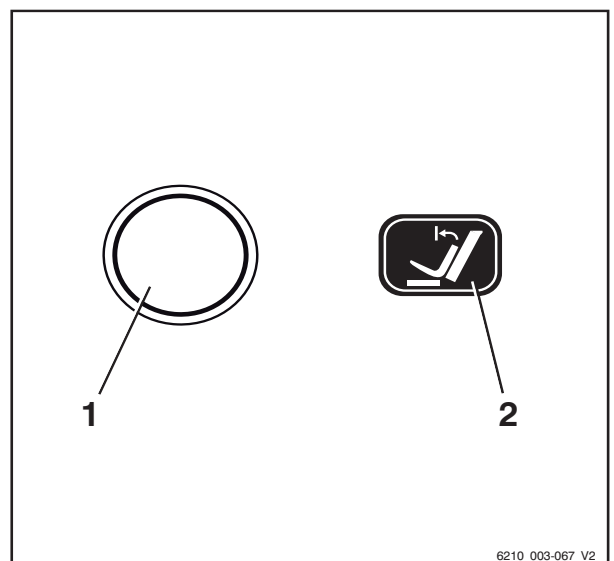

Gentle running-in to the end stops

The lift mast is braked gently at the end of the tilt range. This prevents the lift mast from stopping harshly in the end position and reduces severe oscillating motions of the truck.

4 Operation
Lifting

Tilting the lift mast forwards with the "lift mast vertical position"

- Actuate the button (1) to switch on the "lift mast vertical position" comfort feature; the function display (2) in the display shows the activated status.
- Tilt the lift mast forwards.

i NOTE

The way in which the lifting system is operated depends on the operating devices included in the truck's equipment; see the chapter entitled "Lifting system operating devices".

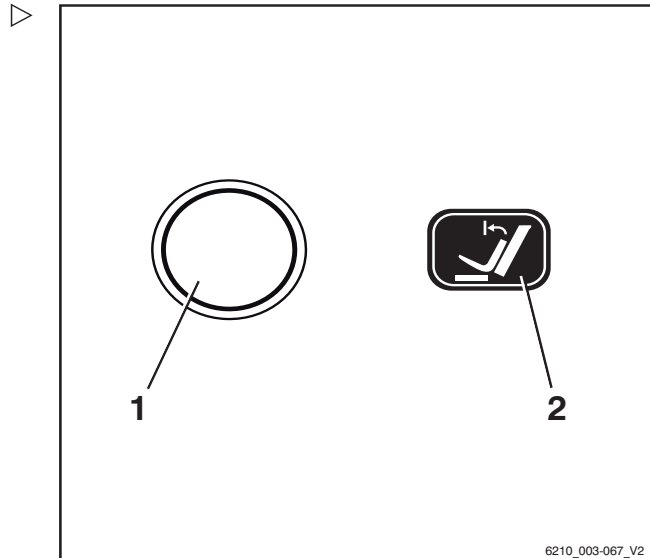

The lift mast is tilted forwards and stops as soon as the vertical position is reached. The arrow above the bar shown on the screen of the display and operating unit represents the "lift mast vertical position".

Tilting the lift mast forwards beyond the vertical position:

- Release the operating device for tilting and actuate again.

The lift mast is tilted beyond the vertical position up to the end stop. The current mast tilt is shown in the display and operating unit.

- To deactivate the "lift mast vertical position", actuate the button (1) again.

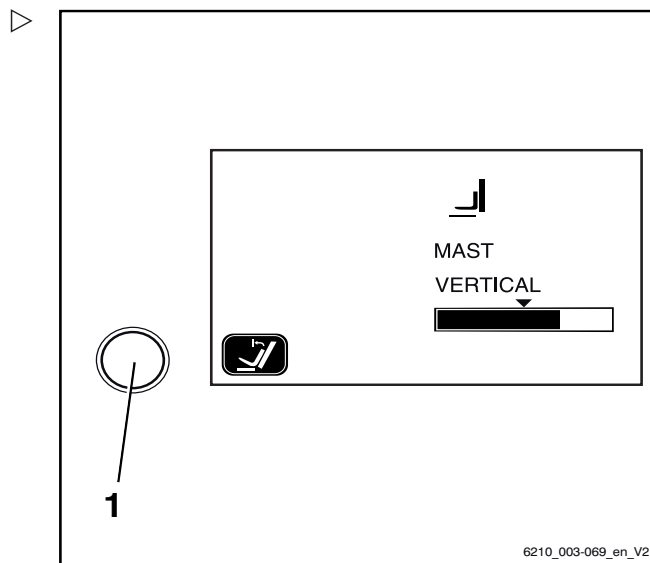

Tilting the lift mast backwards with the "lift mast vertical position"

- Tilt the lift mast backwards.

The lift mast is tilted backwards without stopping in the vertical position.

Possible restrictions on the "lift mast vertical position"

In some circumstances, the lift mast cannot move exactly into the preset vertical position. Possible causes include:

- Uneven ground
- Bent fork
- Bent attachment
- Worn tyres
- Severely deformed lift mast

The vertical position can be corrected by tilting the lift mast using the relevant operating device. If the vertical position has to be corrected frequently, the "lift mast vertical position" should be calibrated.

Calibrating the "lift mast vertical position" ▷

- Set the lift mast to the required position.
- Press and hold the button (1) for the "lift mast vertical position" for at least five seconds.

The message "? VERTICAL POSITION" will appear on the display.

Storing the mast position:

- Press the drive program selection button (3).

The current mast position is stored.

Cancelling calibration:

- Press the menu change button (2).

The calibration is cancelled.

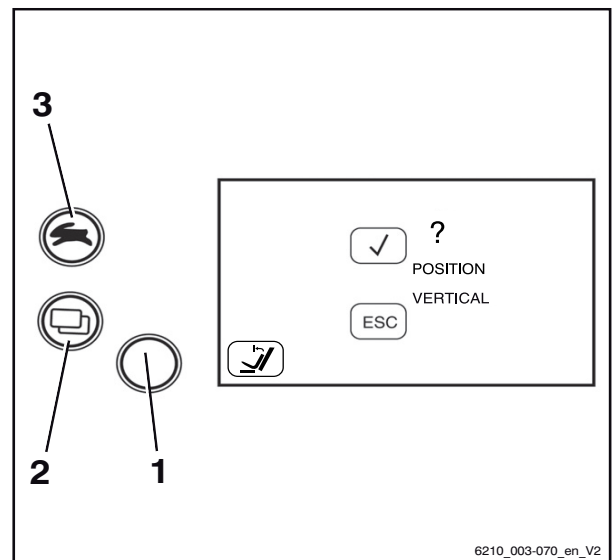

Handling loads

Handling loads

Safety regulations when handling loads

The safety regulations for handling loads are shown in the following sections.

⚠ DANGER

There is a risk to life caused by falling loads or if parts of the truck are being lowered.

- Never walk or stand underneath suspended loads or raised fork arms.
- Never exceed the maximum load indicated on the capacity rating plate. Otherwise stability cannot be guaranteed!

⚠ DANGER

Risk of accident from falling or crushing!

- Do not step onto the forks.
- Do not lift people.
- Never grab or climb on moving parts of the truck.

⚠ DANGER

Risk of accident from a falling load!

- When transporting small items, attach a load safety guard (variant) to prevent the load from falling on the driver.
- Use a closed roof covering (variant) in addition.



Before taking up load

Load capacity

The load capacity indicated for the truck on the capacity rating plate may not be exceeded. The load capacity is influenced by the load centre of gravity and the lift height as well as by the tyres, if applicable.

The position of the capacity rating plate can be found in the chapter entitled "Identification points".

⚠ WARNING

The figures show examples.

Only the capacity rating plates on the truck are valid!

The attachment of additional weights to increase load capacity is prohibited.

⚠ DANGER

Risk to life from the truck losing stability!

Never exceed the maximum loads shown! These values apply to compact and homogenous loads. Otherwise, the stability as well as the rigidity of the fork arms and lift mast cannot be guaranteed.

Improper or incorrect operation or the placement of persons to increase load capacity is prohibited.

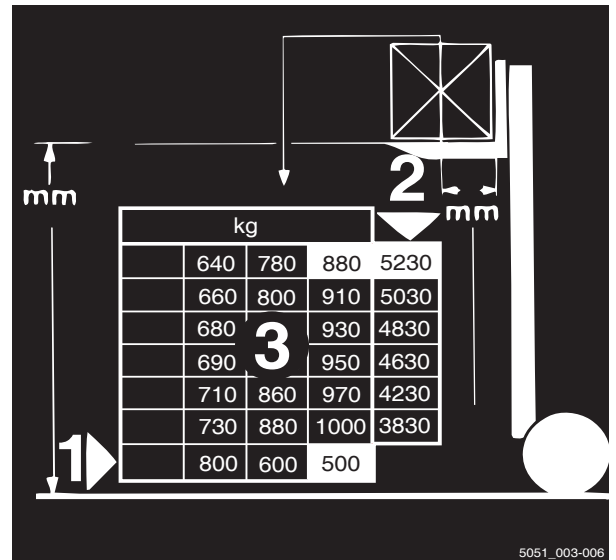

5051_003-006

4 Operation
Handling loads

Example

- Weight of load to be lifted: 880 kg (3)
- Load distance from fork back: 500 mm (1)
- Permitted lift height: 5230 mm (2)

⚠ WARNING

Risk of accident from the truck losing stability!
The permissible load of the attachments (variant) and the reduced lifting capacity of the combination of truck and attachment must not be exceeded.

- Observe the special capacity rating plate information shown on the truck and the attachment.

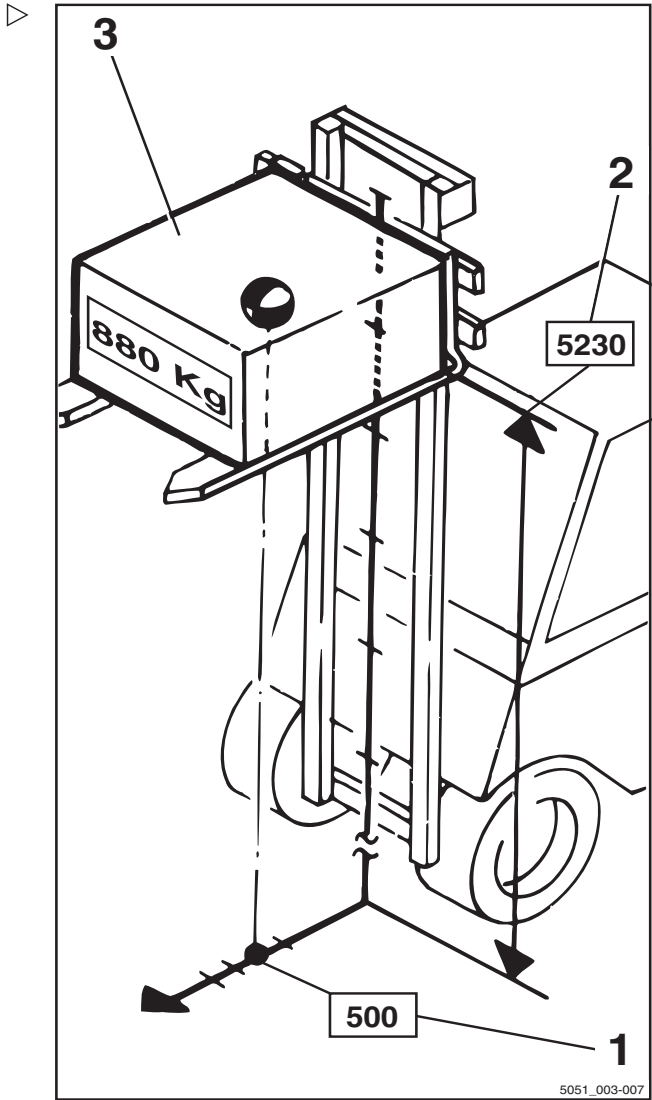

Load measurement (variant)

Description

Knowing the weight of the load to be transported gives the driver greater security. If the truck is equipped with the "load measurement" (variant) comfort feature, the weight of the lifted load can be measured and shown in the display and operating unit.

Load measurement is possible only when the truck is at a standstill. Before performing a load measurement, the load must be raised to a height of 300-800 mm above the ground.

The load measurement has an accuracy of +/-3% of the rated capacity of the truck.

 **NOTE**

In order to ensure accuracy at all times, a zero adjustment of the load measurement must be carried out. Zero adjustment is required.

- *as part of daily commissioning*
- *after changing the fork arms*
- *after fitting or changing attachments.*

Performing the load measurement

 **DANGER**

Risk of accident from a falling load!

The load may fall if the load centre of gravity has not been taken into account or the load has not been picked up securely.

- Pick up the load securely; see the chapter entitled "Picking up loads".

 **CAUTION**

If the weight determined by a load measurement exceeds the permissible residual load capacity of the truck, the truck cannot be operated safely.

- Set down and reduce load immediately.
- If necessary, use another truck with sufficient load-bearing capacity.

 **NOTE**

Accurate load measurement is only possible under the following conditions:

- *The hydraulic oil is at normal operating temperature*
- *The load is at rest at the beginning of the load measurement*
- *The load corresponds to at least 10% of the nominal load capacity in trucks with a load capacity of up to 2.5 t*
- *The load corresponds to at least 5% of the nominal load capacity in trucks with a load capacity of 3 t and over*
- *The lift mast is in the vertical position*
- *The fork is not raised to more than 800 mm above the ground*

4 Operation

Handling loads

i NOTE

The method of operating the lifting system depends on the operating devices included in the truck's equipment.

- Ensure that the truck has been in operation for a period of time before carrying out the load measurement.
- Set lift mast to vertical.
- Raise the fork to a height of 300–800 mm.
- Ensure that the load is at rest.
- Press Softkey (1).

Load measurement is switched on. The (2) symbol is displayed.

i NOTE

*If the truck is equipped with mini-levers or fingertip operation, the **F1** button can also be pressed as an alternative.*

i NOTE

During the following process, the fork carriage must be lowered slightly and then stopped abruptly. While doing so, the fork must not touch the ground, otherwise the load measurement will not be accurate. To stop the lowering procedure quickly, release the operating device for lowering so that it jumps into the zero position.

- Lower the fork carriage slightly and release the operating device.

i NOTE

When stopping the lowering process the load must be cushioned in order to create a measurable impulse.

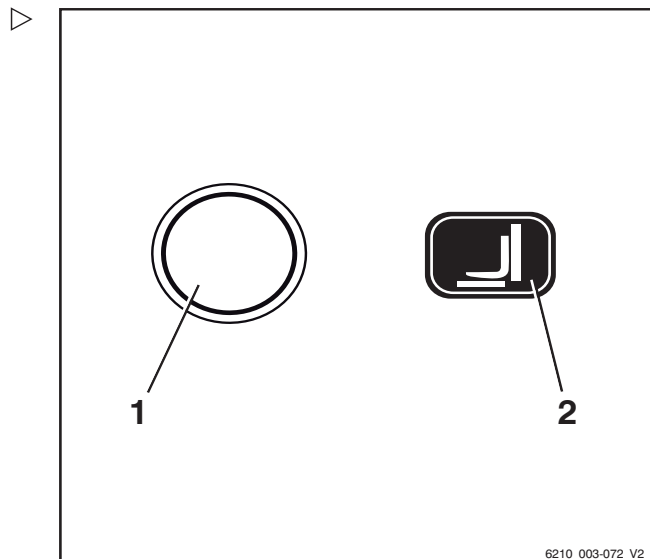

When load measurement has been performed correctly, the determined load weight (3) is shown on the display.

i NOTE

If the load measurement is invalid, the value "-9999 kg" is displayed in the operating unit.

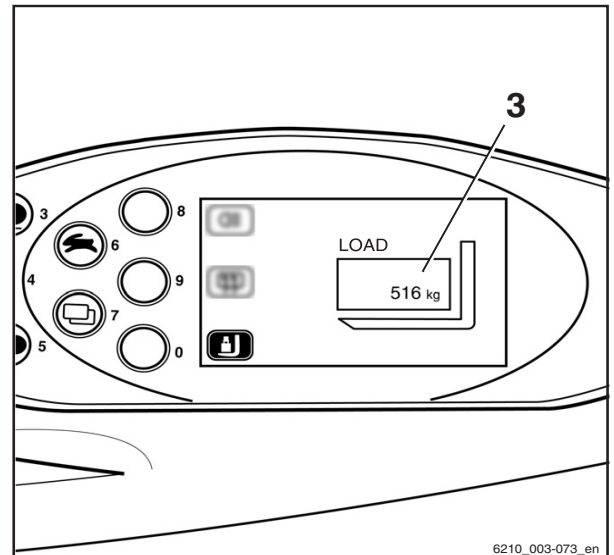

Picking up loads

To make sure that the load is securely supported, it must be ensured that the fork arms are sufficiently far apart and are positioned as far as possible under the load.

If possible, the load should rest on the back of the fork.

The load must not protrude too far over the fork tips, nor should the fork tips protrude too far out from the load.

Loads are to be picked up and transported as close to the middle as possible.

⚠ DANGER

Risk of accident from a falling load!

When transporting small items, attach a load safety guard (variant) to prevent the load from falling on the driver.

A closed roof covering (variant) should also be used.

Removable roof panels may not be removed.

4 Operation

Handling loads

Adjusting the fork

- Lift the locking lever (1) and move the fork arms to the desired position.
- Allow the locking lever to snap back into place.

The load centre of gravity must be midway between the fork arms.

- Only actuate the fork prong positioner (variant) when the fork is not carrying a load.

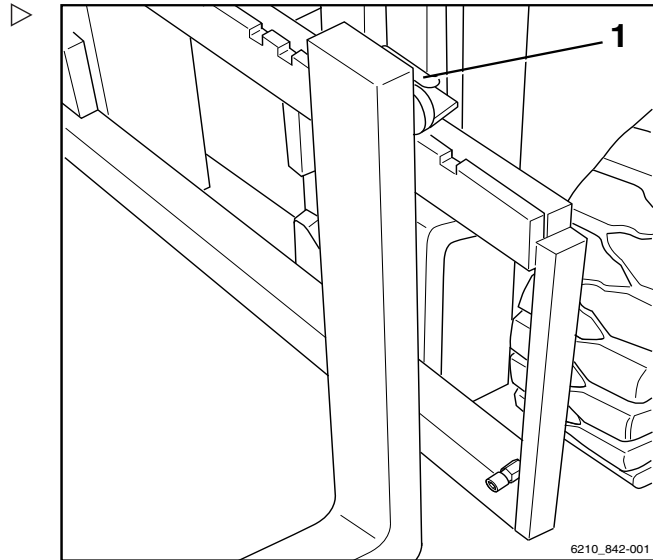

Danger area

The danger area is the area in which people are at risk due to the movements of the truck, its working equipment, its load-carrying equipment (e.g. attachments) or the load. Also included are the areas where loads could fall or working equipment could fall or be lowered.



⚠ DANGER

Risk of injury!

- Do not step on the fork.



⚠ DANGER

Risk of injury!

- Do not step under the raised forks.

⚠ DANGER

People may be injured in the danger area of the truck!

The danger area of the truck must be completely clear of all personnel, except the driver in his normal operating position. If persons fail to leave the danger area despite warnings:

- Cease work with the truck immediately.
- Secure the truck against use by unauthorised parties.



⚠ DANGER

Danger of death from falling loads!

- Never walk or stand underneath suspended loads.

Transporting pallets

As a rule, loads (e.g. pallets) must be transported individually. Transporting multiple loads at the same time is only permitted:

- when instructed by the supervisor and
- when the technical requirements have been met.

The driver must ensure proper condition of the load. Only safely and carefully positioned loads may be transported.

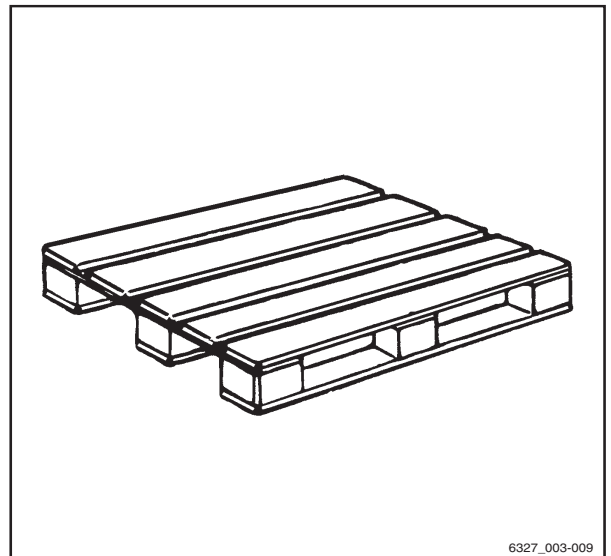

6327_003-009

Transporting suspended loads

Before transporting suspended loads, consult the national regulatory authorities (in Germany, the employer's liability insurance associations).

National regulations may place restrictions on these operations. Contact the relevant authorities.

⚠ DANGER

Suspended loads that begin to swing can result in the following risks:

- Impaired braking and steering action
- Tipping over the load wheels or drive wheels
- Tipping the truck at right angles to the direction of travel
- Risk of crushing of guide persons
- Reduced visibility.



6210_001-007

Handling loads

⚠ DANGER

Loss of stability.

Slipping or swinging suspended loads can lead to a loss of stability and cause the truck to tip over.

- When transporting suspended loads, observe the following instructions

Instructions for transporting suspended loads:

- Swinging loads must be prevented by using the proper driving speed and driving style (careful steering, braking)
- Hanging loads must be hooked on to the truck in such a way that the harness cannot shift or release unintentionally and cannot be damaged
- When transporting suspended loads, suitable devices (e.g. guy wires or supporting poles) must be available so that accompanying persons can guide suspended loads and prevent the loads from swinging
- Take particular care to ensure that there is no one in the drive direction in the driving lane
- If, despite this, the load begins to swing, ensure that no person is placed at risk

⚠ DANGER

Risk of accidents!

When transporting hanging loads, never perform or end driving and load movements abruptly.

Never drive on slopes with a suspended load.

Transporting containers holding fluids as hanging loads is not permitted.

Load pick up

⚠ DANGER

There is a risk to life caused by a falling load or if parts of the truck are being lowered.

- Never walk or stand underneath suspended loads or raised fork arms.
- Never exceed the maximum load values specified on the capacity rating plate. Otherwise, stability cannot be guaranteed.
- Only store pallets which do not exceed the specified maximum size. Damaged loading

Operation

4

Handling loads

equipment and incorrectly formed loads must not be stored.

- Attach or secure the load to the load-carrying equipment so that the load cannot move or fall.
- Store the load so that the specified aisle width is not reduced by protruding parts.
- Approach the racking carefully, brake gently and stop just in front of the racking. ▷

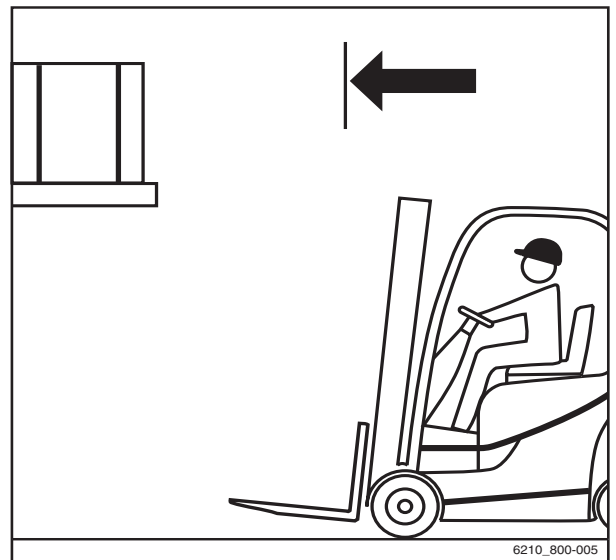

- Position the forks. ▷
- Set lift mast to vertical.
- Lift the fork carriage to the stacking height.

⚠ CAUTION

Component damage possible!

When inserting the fork into the racking, ensure that the racking and load are not damaged.

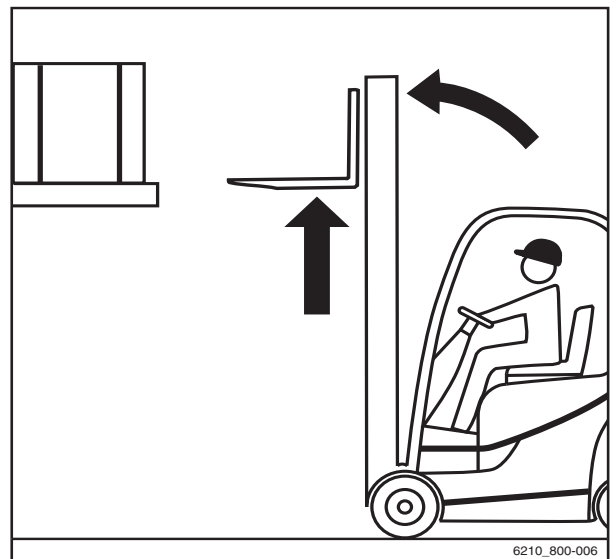

4 Operation

Handling loads

- Insert the fork as far under the load as possible. Stop the truck as soon as the fork back is resting on the load. The centre of gravity of the load must be positioned between the fork arms in the middle.

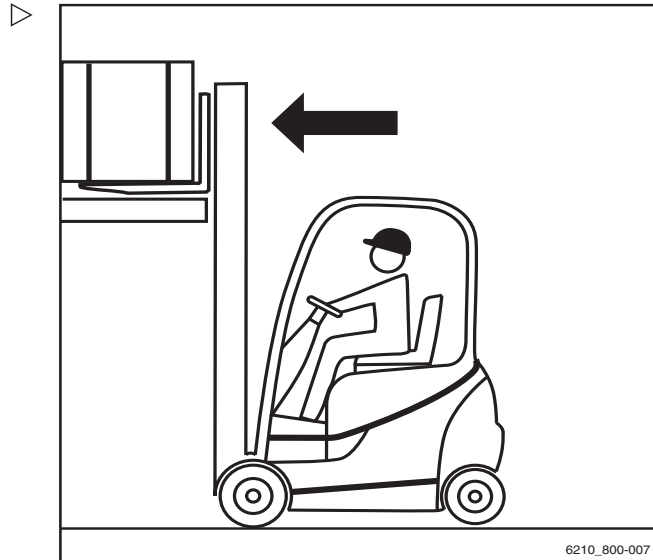

- Lift the fork carriage until the load is resting entirely on the forks.

⚠ DANGER

Risk of accidents!

- Beware of any people in the danger area.
- Ensure that the roadway behind you is clear.

⚠ DANGER

Never tilt the lift mast with a raised load due to the risk of tipping!

- Lower the load before tilting the lift mast.
- Move backwards carefully and slowly until the load is clear of the racking. Brake gently.

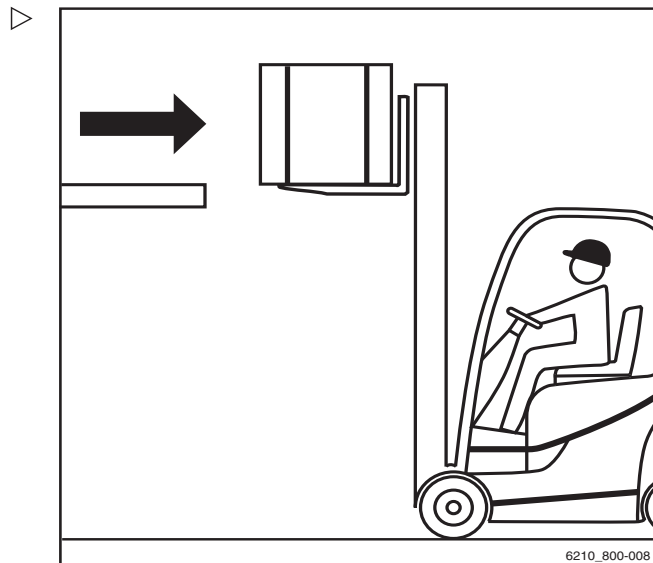

Operation

4

Handling loads

- Lower the load while maintaining ground clearance.

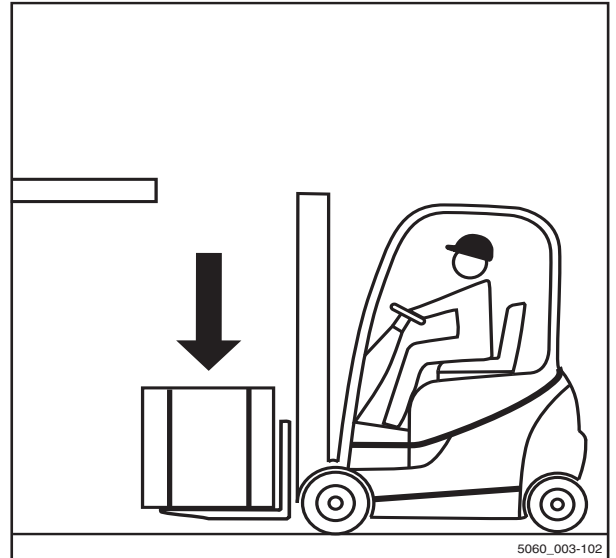

- Tilt the lift mast backwards.
The load can be transported.

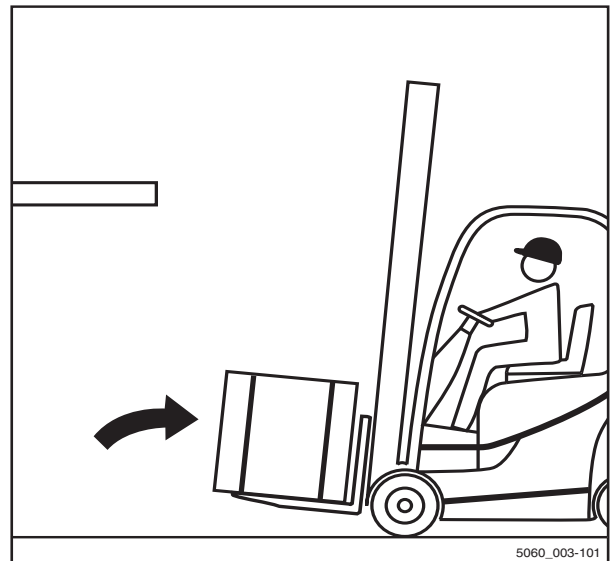

4 Operation

Handling loads

Transporting loads

i NOTE

Observe the information in the chapter entitled "Safety regulations when driving".

⚠ DANGER

The higher a load is lifted, the less stable it becomes. The truck can tip over or the load can fall, increasing the risk of accident!

Driving with a raised load and the lift mast tilted forward is not permitted.

- Only drive with the load lowered.
- Lower the load until ground clearance is reached (not over 300 mm).
- Only drive with the lift mast tilted backwards.

- Drive slowly and carefully round corners!

i NOTE

Observe the information in the chapter entitled "Steering".

- Always accelerate and brake gently!

i NOTE

Observe the information in the chapter entitled "Operating the service brake".

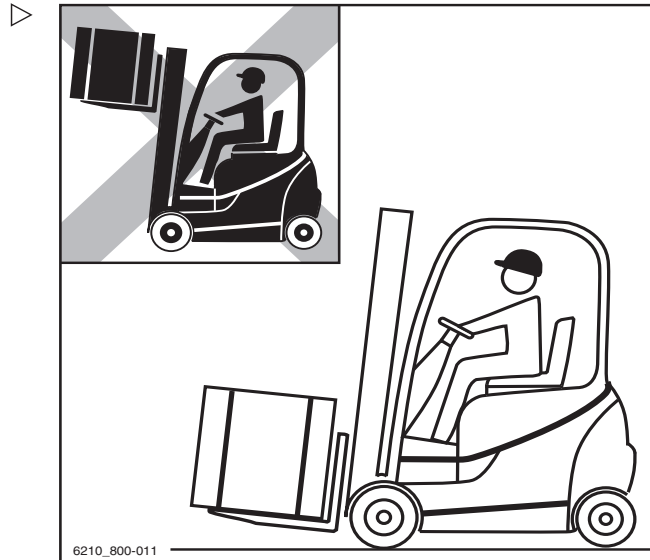

- Never drive with a load protruding to the side (e.g. with the sideshift)!



Setting down loads

DANGER

Risk of accident due to changed moment of tilt!

The load centre of gravity and the moment of tilt move due to tilting the lift mast forwards with a raised load or due to the load slipping. The truck may tip forwards.

- Only tilt the lift mast forwards with a raised lifting accessory when it is directly above the stack.
- When the lift mast is tilted forwards, take particular care to ensure that the truck does not tip forwards and that the load does not slip.

WARNING

Risk of accident from a falling load!

If the fork or the load remains suspended during lowering, the load may fall.

- When removing from stock, move the truck far enough back so that the load and the fork can be lowered freely.

4 Operation

Handling loads

- Drive up to the stack with the load lowered in accordance with regulations. ▷
- Set lift mast to vertical.
- Lift the load to the stacking height.
- Drive the truck towards the rack carefully.

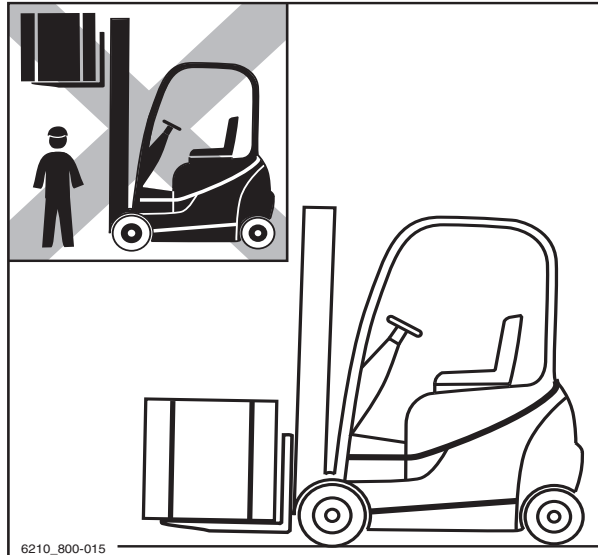

- Lower the load until it rests securely on the rack. ▷

⚠ DANGER

Risk of accident!

- Beware of any people in the danger area.
- Ensure that the roadway behind you is clear.

- Move the truck back until the fork arms can be lowered without touching the stack.
- Lower the fork while maintaining ground clearance.
- Tilt the lift mast backwards and drive away.

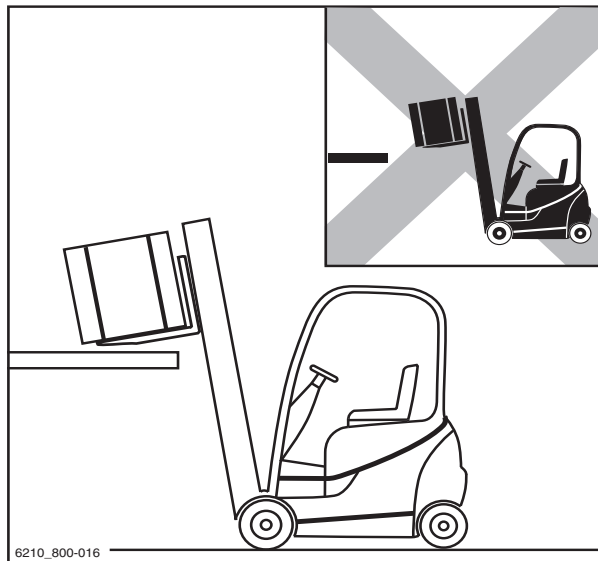

Driving on ascending and descending gradients

⚠ DANGER

Danger to life!

Driving on ascending and descending gradients carries special dangers!

- Always follow the instructions below.

- On ascending and descending gradients, the load must be carried facing uphill.
- It is only permitted to drive on ascending and descending gradients that are marked as traffic routes and that can be used safely.
- Ensure that the ground to be traversed is clean and provides a good grip.
- Do not turn on ascending and descending gradients.
- Do not drive onto or along ascending and descending gradients at an angle.
- Do not park the truck on ascending or descending gradients.
- In case of emergency, secure the truck with wedges so that the truck does not roll away.
- Reduce the driving speed on descending gradients.

It is not permitted to drive on long ascending and descending gradients greater than 15% due to the specified minimum braking and stability values.

- Before driving on ascending and descending gradients greater than 15%, consult the authorised service centre.

The process of placing loads into stock and removing loads from stock while on an ascending or descending gradient is not permitted!

- Always place loads into stock and remove loads from stock on a horizontal plane.



4 Operation

Handling loads

Driving on lifts

The driver is only allowed to use this truck on lifts with a sufficient load capacity and for which the operating company (see ⇒ Chapter "Definition of responsible persons", P. 26) has been granted authorisation.

⚠ DANGER

There is a risk to life from being crushed or run over by the truck.

- There must be no personnel already in the lift when the truck is driven into the lift.
- Personnel are only permitted to enter the lift once the truck is secure, and must exit the lift before the truck is driven out.

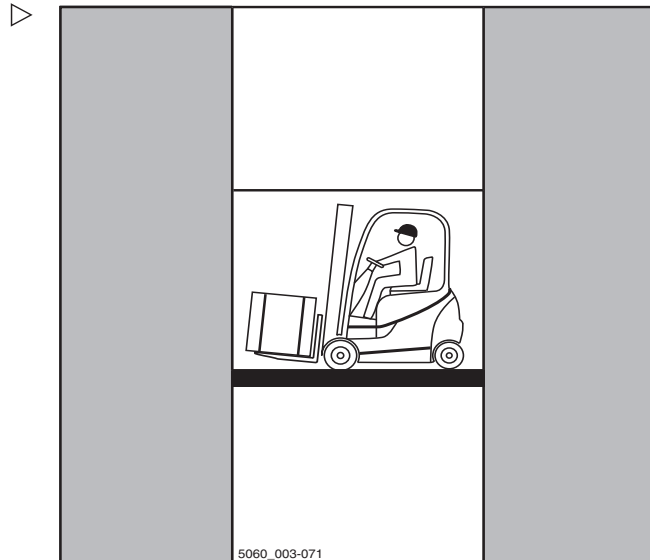

Determining the actual total weight

- Park the truck securely, see ⇒ Chapter "Parking the truck securely and switching it off", P. 4-160.
- Determine the unit weights by reading the truck nameplate and, if necessary, the attachment (variant) nameplate and, if necessary, by weighing the load to be lifted.
- Add the determined unit weights to obtain the actual total weight of the truck:

- Tare weight (1)
- + Max. permissible battery weight (2)
- + Ballast weight (variant) (3)
- + Net weight of attachment (variant)
- + Weight of the load to be lifted
- + 100 kg allowance for the driver
- = Actual total weight

- Drive the truck with the forks forwards into the lift without touching the shaft walls.
- Park the truck securely in the lift, see ⇒ Chapter "Parking the truck securely and switching it off", P. 4-160, to prevent uncontrolled movements of the load or the truck.

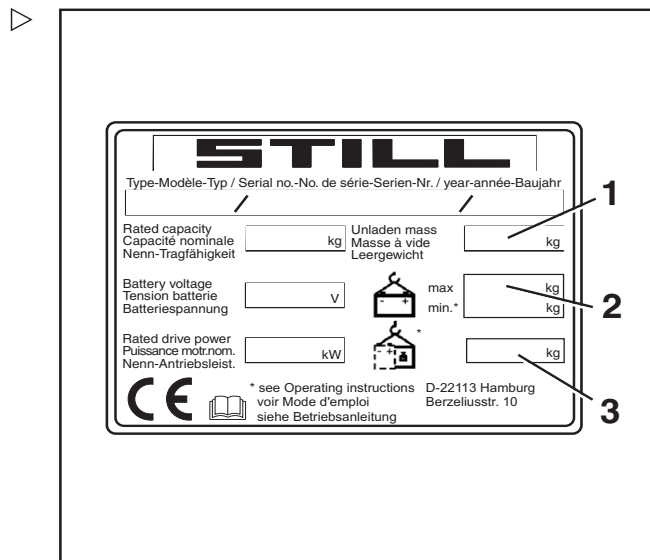

Driving on loading bridges

⚠ DANGER

Risk of accident from the truck crashing!

Steering movements can cause the tail end to veer off the loading bridge towards the edge. This may cause the truck to crash

The lorry driver and the truck driver must agree on the lorry's departure time.

- Establish the departure time of the lorry.
- Determine the total actual weight of the truck.
- Before driving across a loading bridge, ensure that it is properly attached and secured and has a sufficient load capacity (lorry, bridge etc.).
- Ensure that the vehicle onto which you will be driving is secured to prevent it from shifting and that it can support the load of the truck.

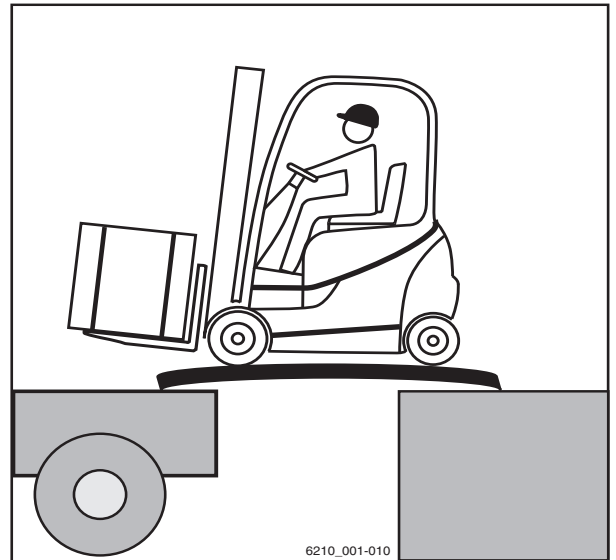

Determining the total actual weight

- Park the truck securely.
- Determine the unit weights by reading the truck nameplate and, if necessary, the attachment (variant) nameplate and, if necessary, by weighing the load to be lifted.
- Add the determined unit weights to obtain the total actual weight of the truck:

Tare weight (1)

+ Max. permissible battery weight (2)

+ Ballast weight (variant) (3)

+ Attachment net weight (variant)

+ Weight of the load to be lifted

+ 100 kg allowance for driver

= Total actual weight

- Drive slowly and carefully on the loading bridge.

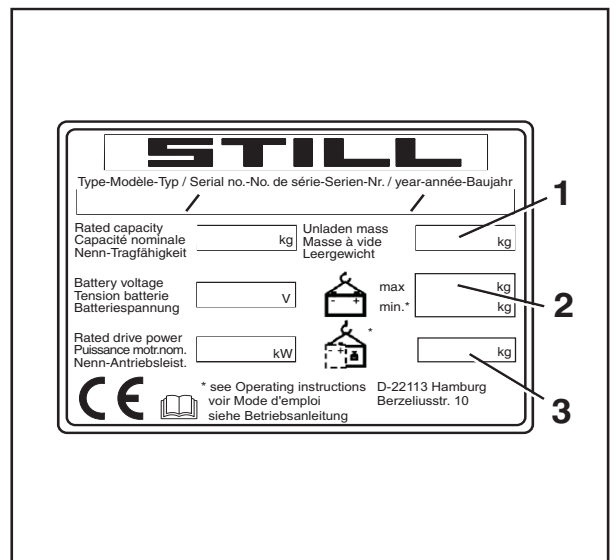



Attachments

Attachments

Fitting attachments

If the truck is equipped with an integrated attachment (variant) at the factory, the specifications in the STILL operating instructions for integrated attachments must be observed.

If attachments are fitted at the place of use, the specifications in the operating instructions of the attachment manufacturer must be observed.

If an attachment is not delivered together with the forklift truck, the specifications and operating instructions of the attachment manufacturer must be observed.

Before initial commissioning, the function of the attachment and the visibility from the driver's position with and without a load must be checked by a competent person. If the visibility is deemed insufficient, visual aids such as mirrors, a camera/monitor system etc. must be used.

In addition, it is essential that the warnings below are observed.

⚠ CAUTION

Attachments must be CE-certified. If the truck is not fitted with an attachment-specific residual load capacity rating plate and the operating devices are not marked with corresponding pictograms, the truck must not be used.

- Order the residual load capacity rating plate and pictograms from your authorised service centre in good time.
- The authorised service centre must adapt the hydraulic system to the requirements of the attachment (e.g. by adjusting the pump motor speed).

⚠ DANGER

There is risk to life caused by a falling load!

Attachments that hold the load by exerting pressure on it (e.g. clamps) must be controlled additionally by a second operating function (lock) that is actuated to prevent an unintentional release of the load.

If such an attachment is retrofitted, a second operating function for actuation must also be retrofitted.

- Make sure that the additional clamp locking mechanism function is available.

⚠ DANGER

There is risk to life caused by a falling load!

During installation of a clamp with integral sideshift, ensure that the clamp does not open when the sideshift is actuated.

- Notify your authorised service centre before installation.
- Never grab or climb on moving parts of the truck.

Hydraulic connection

- Before installing the attachment, release the pressure from the hydraulic system.

⚠ CAUTION

Risk of damage to components!

Open connections of plug connectors can become dirty. The plug connectors can become stiff and dirt can enter the hydraulic system.

- Once the attachment has been disassembled, attach the protective caps to the plug connectors.

Mounting attachments

Mounting an attachment and connecting the energy supply for an attachment must only be performed by competent persons in accordance with the information provided by the manufacturer and supplier of the attachment. After each installation, the attachment must be checked for correct function prior to initial commissioning.

i NOTE

Please observe the definition of the following responsible person: "competent person".

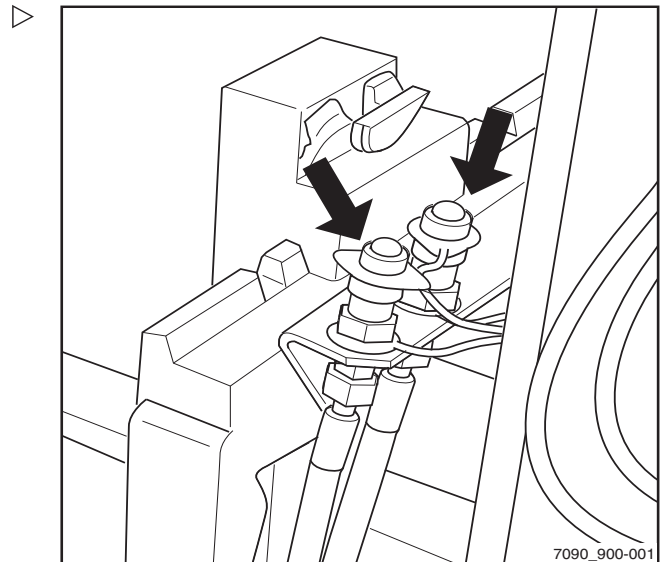

Attachments

Load capacity with attachment

The permissible load capacity of the attachment and the allowable load (load capacity and load moment) of the truck must not be exceeded by the combination of attachment and payload. The specifications of the manufacturer and supplier of the attachment must be complied with.

- Observe the residual load capacity rating plate, see the chapter entitled "Taking up a load using attachments".

Releasing the pressure from the hydraulic system

⚠ WARNING

The movements of the load lift system present a risk of crushing.

During the process described below, the fork carriage or the lift mast can only be moved slightly.

- Do not reach into or stand below the components of the load lift system.

Non-clamping attachments are connected to the third hydraulic circuit via the plug connectors on the fork carriage and are controlled via the "5th hydraulic function".

- Before fitting attachments, the pressure must be released from the plug connectors (arrows) and the other hydraulic circuits.

Attachments must only be installed by competent persons. The specifications provided by the manufacturer and supplier of the attachments must be observed during installation of the attachments.

- Before each use of the attachment, check and ensure the functions of the installed attachment.

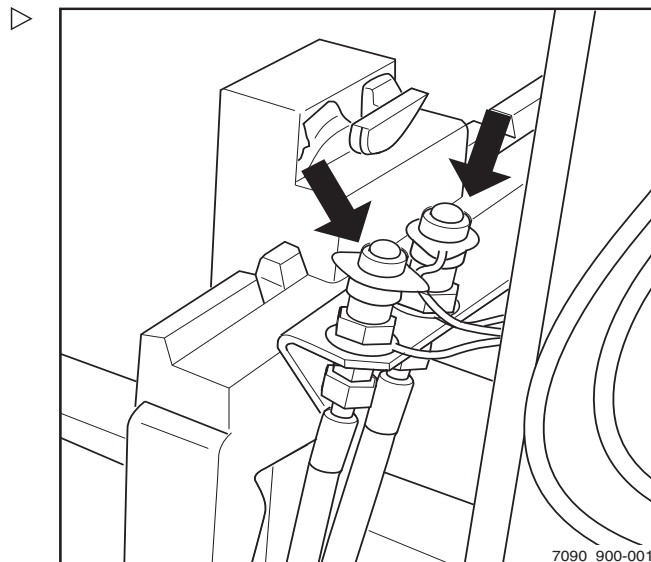

Procedure for multi-lever operation

- Switch on the key switch.
- Lower the fork carriage to the ground.
- Tilt the lift mast backwards to the stop.
- Switch off the key switch.
- Actuate the operating lever (1) several times in the direction of the arrow until the end position is reached.

The hydraulic circuits of the first four hydraulic functions are depressurised.

- Switch on the key switch.
- Lower the fork carriage.
- Switch on the hazard warning system (variant).

i NOTE

Press the button for switching on the hazard warning system even if the truck is not equipped with a hazard warning system. Switching on the hazard warning system prevents the electrical system from being switched off, even if the key switch is subsequently switched off.

- Switch off the key switch.

The message KEY SWITCH appears in the display.

- Press and hold the horizontal rocker button for the 5th function (2).
- While holding down the button, actuate the operating lever several times in the different directions of the arrows until the end position is reached.
- Press and hold the horizontal rocker button for the 5th function (2) in the other switch setting.
- While holding down the push button, actuate the operating lever several times in the different directions of the arrows until the end position is reached.

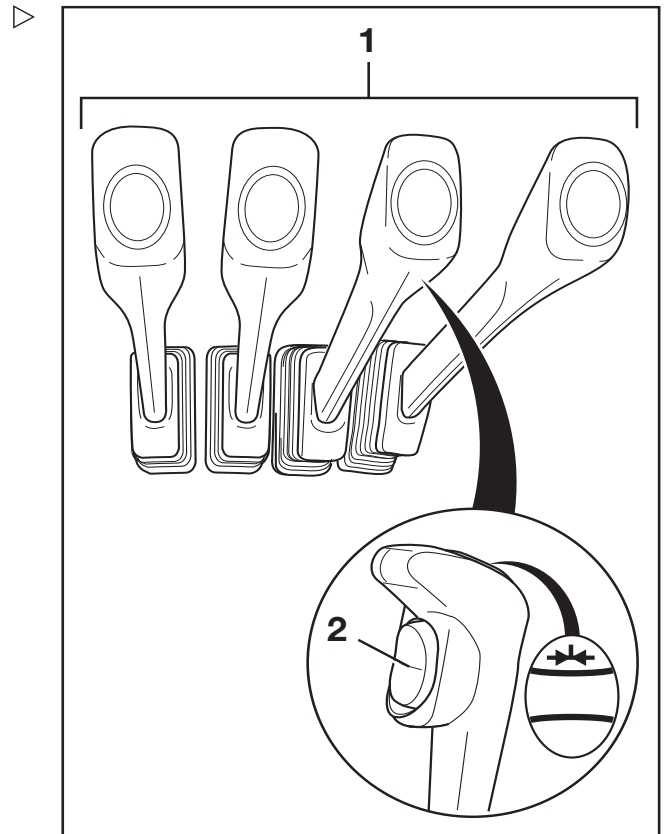



4 Attachments Operation

The hydraulic circuit of the 5th hydraulic function is depressurised. The connections on the lift mast are depressurised.

NOTE

The number of operating levers shown may differ from the truck's equipment.

WARNING

Unintended movement of the lift mast presents a risk of injury.

The hydraulic pump is inactive. If an operating device for the hydraulic functions is accidentally actuated, it may still cause unintended movements of the lift mast.

- **Do not** touch the operating devices.

Procedure for mini-lever control, fingertip operation and Joystick 4Plus operation ▷

i NOTE

In trucks with the "FleetManager" or "access authorisation with PIN code" equipment variants, access authorisation must be enabled.

- Switch on the key switch.
- Lower the fork carriage.
- Switch on the hazard warning system (variant).

i NOTE

Press the button for switching on the hazard warning system even if the truck is not equipped with a hazard warning system. Switching on the hazard warning system prevents the electrical system from being switched off, even if the key switch is subsequently switched off.

- Switch off the key switch.

The message **KEY SWITCH** appears in the display.

- Actuate the operating lever (1) several times in the direction of the arrow until the end position is reached.

The hydraulic circuits of the first four hydraulic functions are depressurised.

- Press and hold the 5. Funktion (2) function key.
- While holding down the button, actuate the relevant operating lever (1) several times in the different directions of the arrows until the end position is reached.

The hydraulic circuit of the 5th hydraulic function is depressurised. The connections on the lift mast are depressurised.

- Release the function key (2).

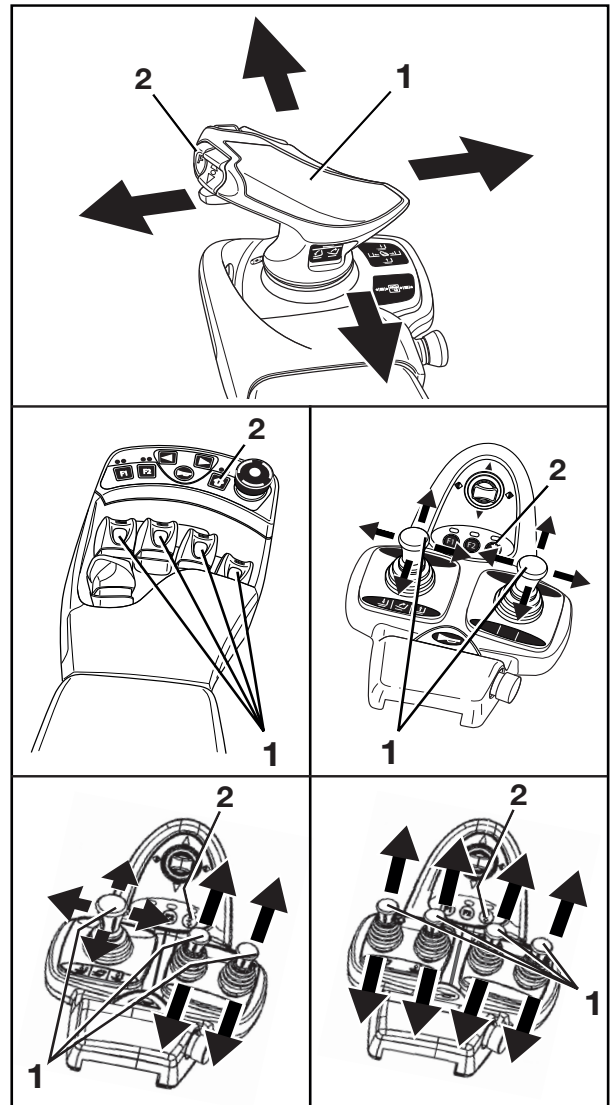

Attachments

General instructions for controlling attachments

The way in which attachments (variant) are controlled depends on the operating devices included in the truck's equipment.

Essentially, a distinction is drawn between:

- **Multiple-lever**
 - **Multiple-lever with a 5th function (variant)**
 - **Double mini-lever**
 - **Double mini-lever with a 5th function (variant)**
 - **Triple mini-lever**
 - **Triple mini-lever with a 5th function (variant)**
 - **Quadruple mini-lever**
 - **Quadruple mini-lever with a 5th function (variant)**
 - **Joystick 4Plus**
 - **Joystick 4Plus with a 5th function (variant)**
 - **Fingertip**
 - **Fingertip with a 5th function (variant)**
- For information on controlling attachments with the respective operating devices, see the relevant sections in this chapter.

WARNING

Use of attachments can give rise to additional hazards such as a change in the centre of gravity, additional danger areas etc.

Attachments must only be used for their intended purpose as described in the relevant operating instructions. Drivers must be taught how to operate the attachments.

Loads may only be picked up and transported with attachments if they are securely grasped and attached. Where necessary, loads must also be secured against slipping, rolling away, falling over, swinging or tipping over. Note that any change to the position of the load centre of gravity will affect the stability of the truck.

- Refer to the capacity rating plate for the attachments being used.

NOTE

Further variants and functions are available in addition to the functions described below. The



directions of movement can be seen on the pictograms on the operating devices.

 **NOTE**

All the attachments described fall into the category of equipment variants. Please see the respective operating instructions for an exact description of the respective movements/actions of the attachment fitted.

4 Operation

Attachments

Controlling attachments using multi-lever operation

In this equipment, the attachments (variant) are controlled via the operating lever (1).

The pictograms on the operating lever show the functions that are activated by this lever.

The meanings are as follows:

- Move operating lever (1) forwards.

The attachment moves in the direction shown in the upper part of the pictogram.

- Move operating lever (1) backwards.

The attachment moves in the direction shown in the lower part of the pictogram.

- Note the following attachment functions and pictograms.

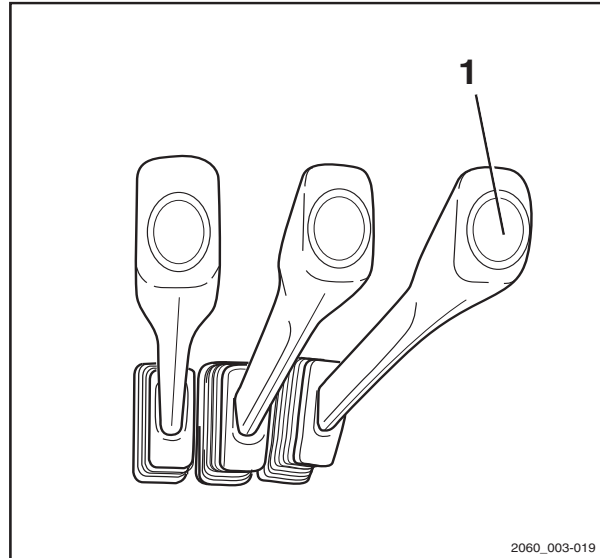

2060_003-019

2	Move side shift frame or fork forwards/backwards
3	Move sideshift to the left/right
4	Adjust fork arms: open/close
5	Swivel lift mast or fork to the left/right
6	Release/clamp load retainer
7	Push off/pull in load
8	Open/close clamps
9	Turn to the left/right
10	Tip shovel over/tip shovel back

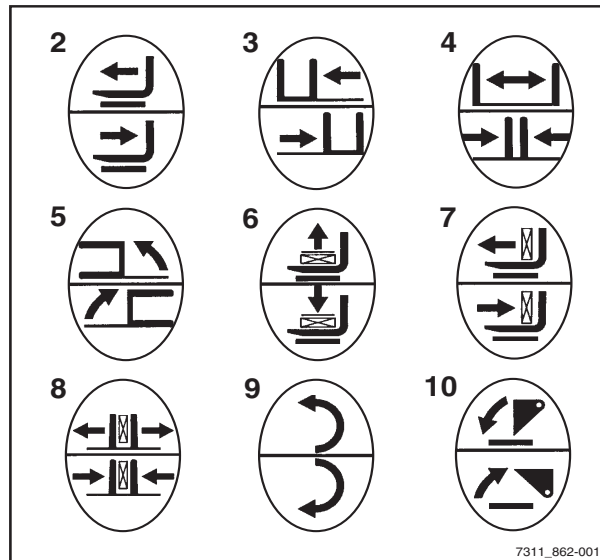

7311_862-001

i NOTE

The pictograms shown correspond to the attachments fitted to this truck at the factory. If an attachment with other functions is fitted, the pictograms must be checked for the correct representation and changed if necessary.

- Contact the authorised service centre if required.

Operating attachments using multi-lever controls and the 5th function

NOTE

For technical reasons, clamping attachments **must not** be controlled via the 5th function.

The attachments (variant) are controlled in this version using operating levers (1) and (2).

On the operating lever (1) you can, with the aid of switch (3), initiate a function changeover so that this operating lever then controls the "5th function".

NOTE

The "5th function" designation refers to the fact that the four operating levers control four functions, while the "5th function" can be controlled by switching functions.

The central and bottom parts of the pictograms on the operating levers always show the function that is activated by that lever. The top part of the pictogram shows that the attachment is equipped with the "5th function".

This essentially involves the following:

- Move the operating lever forwards.

The attachment moves in the direction of movement shown in the centre part of the pictogram.

- Move the operating lever backwards.

The attachment moves in the direction of movement shown in the lower part of the pictogram.

- Actuate the switch

The additional function of the attachment is activated and can be controlled as the "5th function" with the operating lever.

NOTE

Please see the operating instructions of the fitted attachment for the movements/actions resulting from using this "5th function".

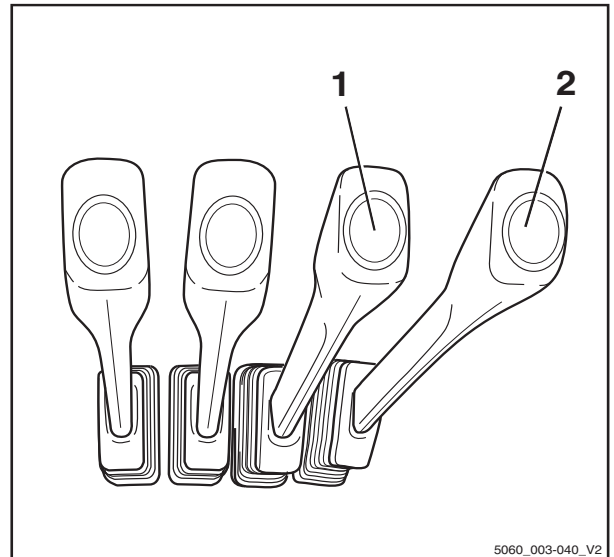

5060_003-040_V2

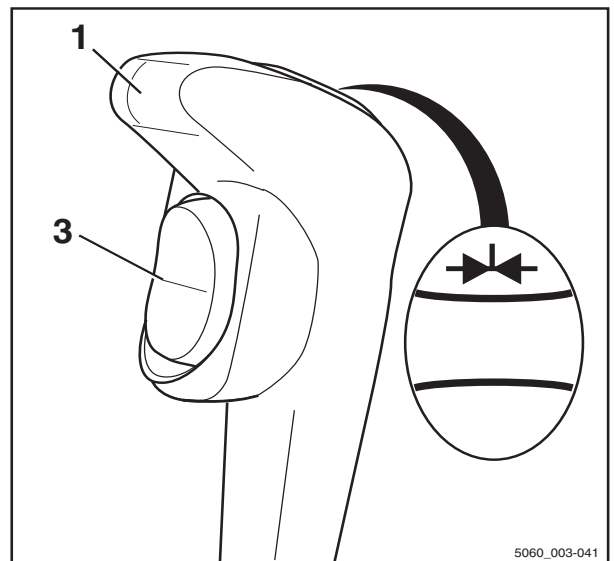

5060_003-041

4 Operation

Attachments

– Note the following attachment functions and pictograms. ▷

2	Move sideshift frame or fork forwards/backwards
3	Move sideshift to the left/right
4	Adjust fork arms: open/close
5	Release/clamp load retainer
6	Push off/pull in load
7	Turn to the left/right
8	Tip shovel over/tip shovel back
9	Swivel lift mast or fork to the left/right

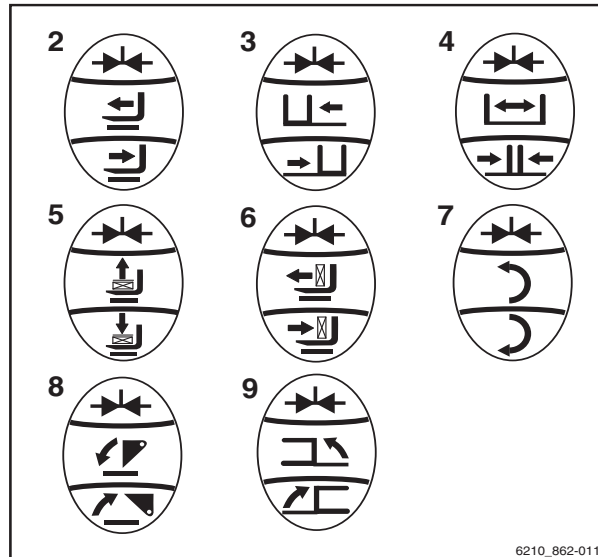

i NOTE

The pictograms shown correspond to the attachments fitted to this truck at the factory. If an attachment with other functions is fitted, the pictograms must be checked for the correct representation and changed if necessary.

– Contact the authorised service centre if required.

Controlling attachments using a double mini-lever

The attachments (variants) are controlled in this version using the "attachments" cross lever (1).

The pictograms on the "attachments" cross lever show the respective functions that are activated by this lever.

This essentially involves the following:

- Move the "attachments"(1) cross lever in the direction of the arrow (A) .

The attachment moves in accordance with the pictogram in position (A).

- Move the "attachments"(1) cross lever in the direction of the arrow (B) .

The attachment moves in accordance with the pictogram in position (B).

- Move the "attachments"(1) cross lever in the direction of the arrow (C) .

The attachment moves in accordance with the pictogram in position (C).

- Move the "attachments"(1) cross lever in the direction of the arrow (D) .

The attachment moves in accordance with the pictogram in position (D).

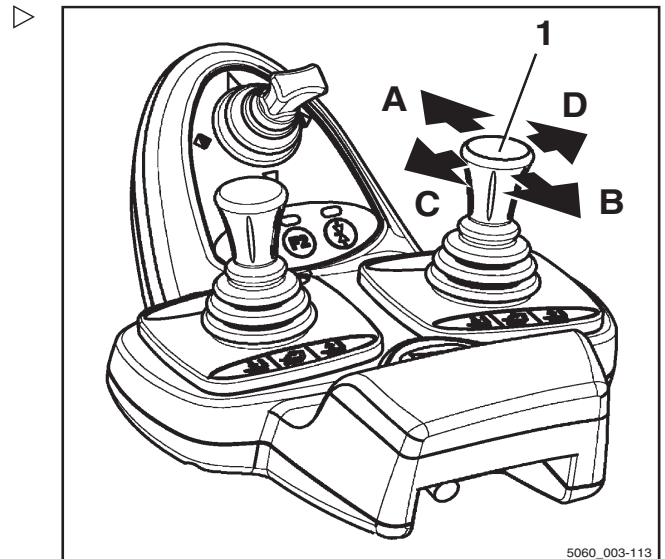

5060_003-113

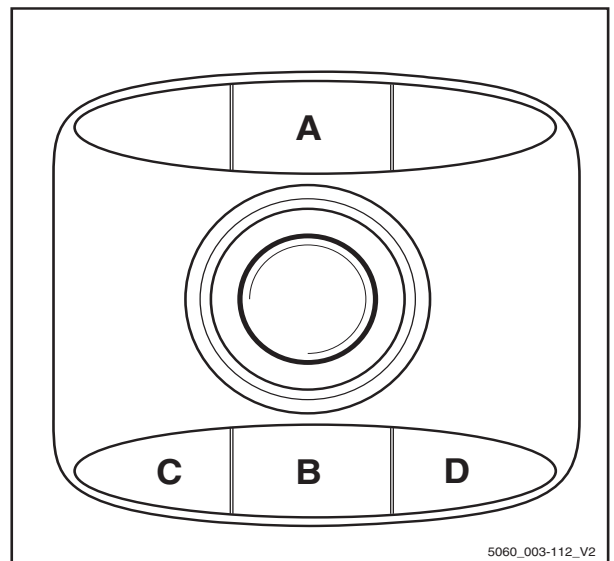

5060_003-112_V2

4 Attachments Operation

– Note the following attachment functions and pictograms. ▷

3	Move sideshift frame or fork forwards
4	Move sideshift frame or fork backwards
5	Move sideshift to the left
6	Move sideshift to the right
7	Adjust fork arms: open
8	Adjust fork arms: close
9	Swivel lift mast or fork to the left
10	Swivel lift mast or fork to the right
11	Release load retainer
12	Clamp load retainer
13	Push off the load
14	Pull in the load
15	Open clamps
16	Close clamps
17	Rotate to the left
18	Rotate to the right
19	Tip shovel over
20	Tip shovel back

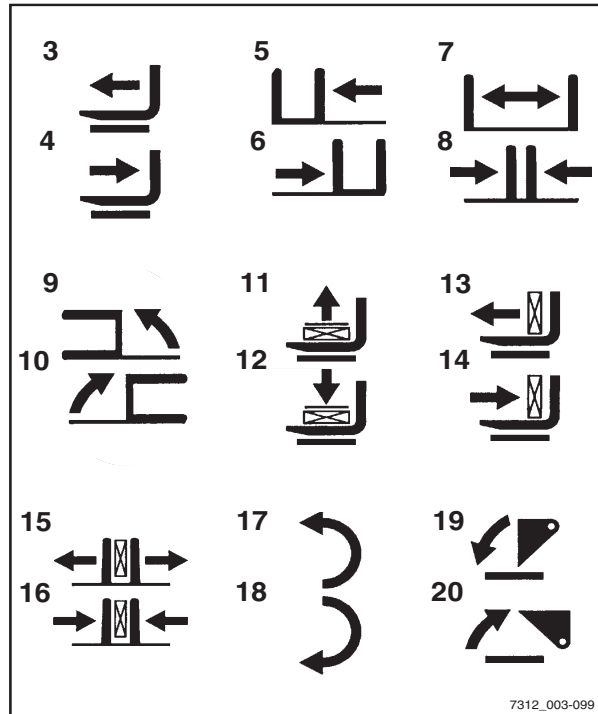

i NOTE

The pictograms shown correspond to the attachments fitted to this truck at the factory. If an attachment with other functions is fitted, the pictograms must be checked for the correct representation and changed if necessary.

– Contact the authorised service centre if required.

Controlling attachments using the double mini-lever and the 5th function

NOTE

For technical reasons, clamping attachments **must not** be controlled via the 5th function.

NOTE

The "lift mast" 360° lever (3) and the "attachments" cross lever (2) control four hydraulic functions. The designation "5th function" refers to the fact that the 5th hydraulic function can be controlled with the cross lever by switching the functions using the "5th function" function key (1).

The pictograms on the "attachments" cross lever (2) show the respective functions that are activated by this lever.

This essentially involves the following:

- Actuate the "5th function" function key (1) and move the "attachments" cross lever (2) in the direction of arrow (E).

The attachment moves in accordance with the pictogram in position (E).

- Actuate the "5th function" function key (1) and move the "attachments" cross lever (2) in the direction of arrow (F).

The attachment moves in accordance with the pictogram in position (F).

NOTE

The pictograms are attached depending on the pre-assembled attachment. If an attachment with other functions is fitted, the pictograms must be checked for the correct representation and changed if necessary.

- Contact the authorised service centre if required.

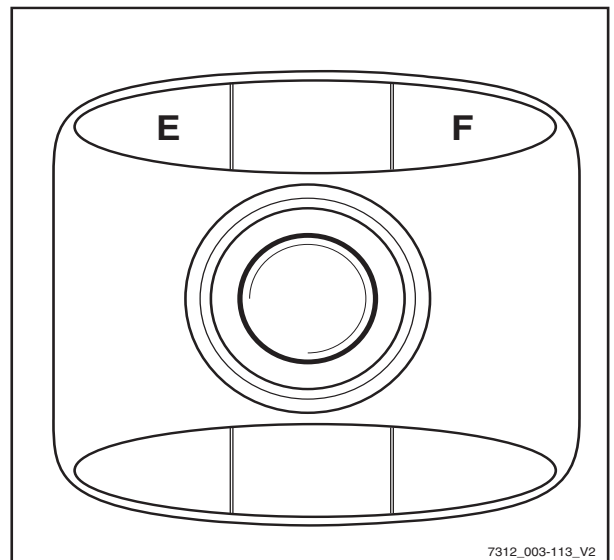
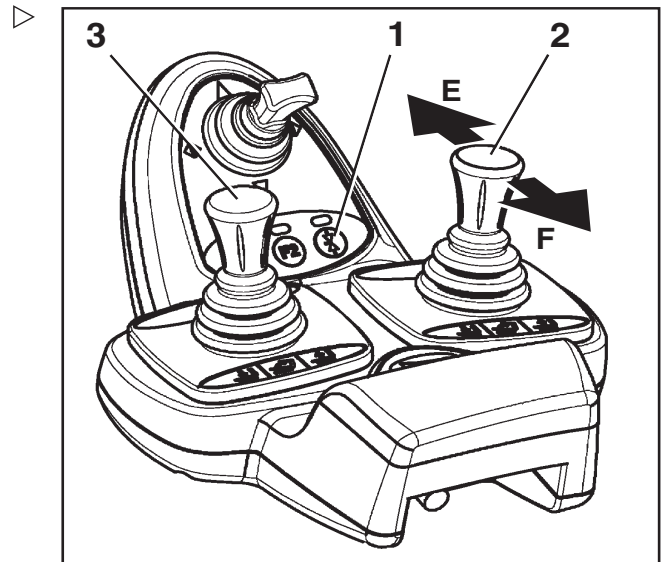

7312_003-113_V2

4 Operation

Attachments

– Note the following attachment functions and pictograms.

3	Move sideshift frame or fork forwards
4	Move sideshift frame or fork backwards
5	Move sideshift to the left
6	Move sideshift to the right
7	Adjust fork arms: open
8	Adjust fork arms: close
9	Swivel lift mast or fork to the left
10	Swivel lift mast or fork to the right
11	Release load retainer
12	Clamp load retainer
13	Push off the load
14	Pull in the load
15	Rotate to the left
16	Rotate to the right
17	Tip shovel over
18	Tip shovel back

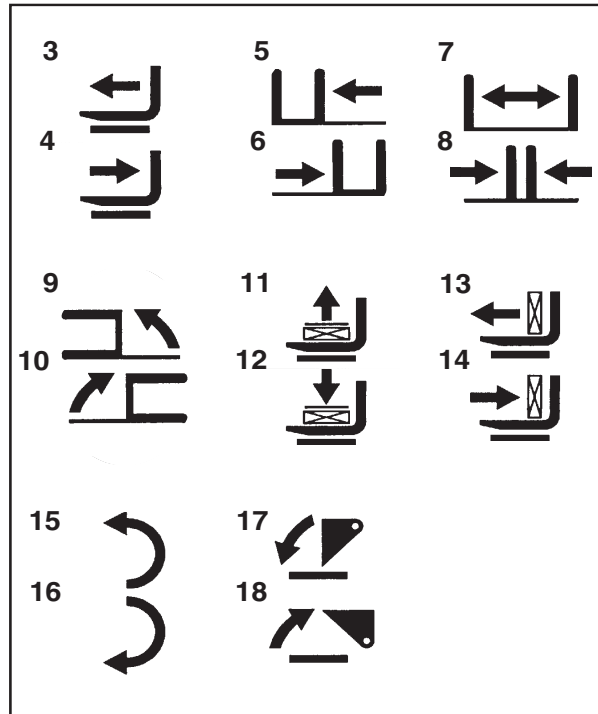

Controlling attachments using a triple mini-lever

The attachments (variant) are controlled in this version using operating levers (1) and (2).

The pictograms on the operating levers show the respective functions that are activated by these levers.

This essentially involves the following:

- Move the operating lever (1) towards (A)

The attachment moves in accordance with the pictogram in position (A).

- Move the operating lever (1) towards (B)

The attachment moves in accordance with the pictogram in position (B).

- Move the operating lever (2) towards (C)

The attachment moves in accordance with the pictogram in position (C).

- Move the operating lever (2) towards (D)

The attachment moves in accordance with the pictogram in position (D).

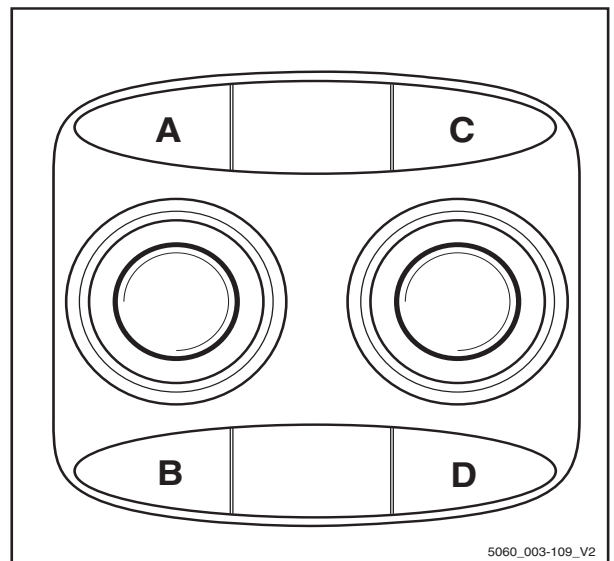
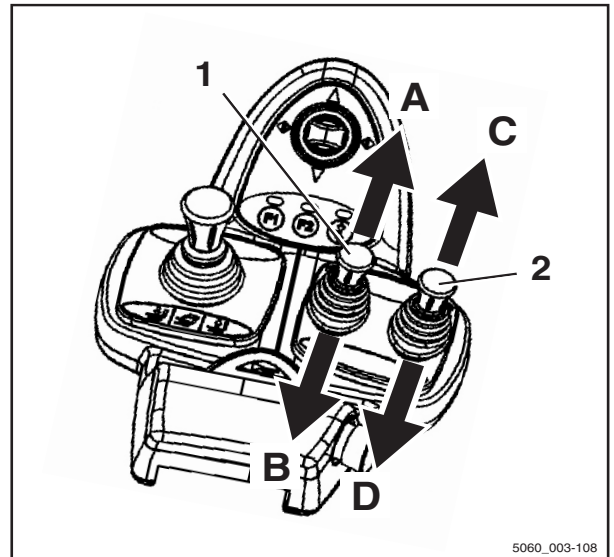

4 Operation

Attachments

– Note the following attachment functions and pictograms.

3	Move sideshift frame or fork forwards
4	Move sideshift frame or fork backwards
5	Move sideshift to the left
6	Move sideshift to the right
7	Adjust fork arms: open
8	Adjust fork arms: close
9	Swivel lift mast or fork to the left
10	Swivel lift mast or fork to the right
11	Release load retainer
12	Clamp load retainer
13	Push off the load
14	Pull in the load
15	Open clamps
16	Close clamps
17	Rotate to the left
18	Rotate to the right
19	Tip shovel over
20	Tip shovel back

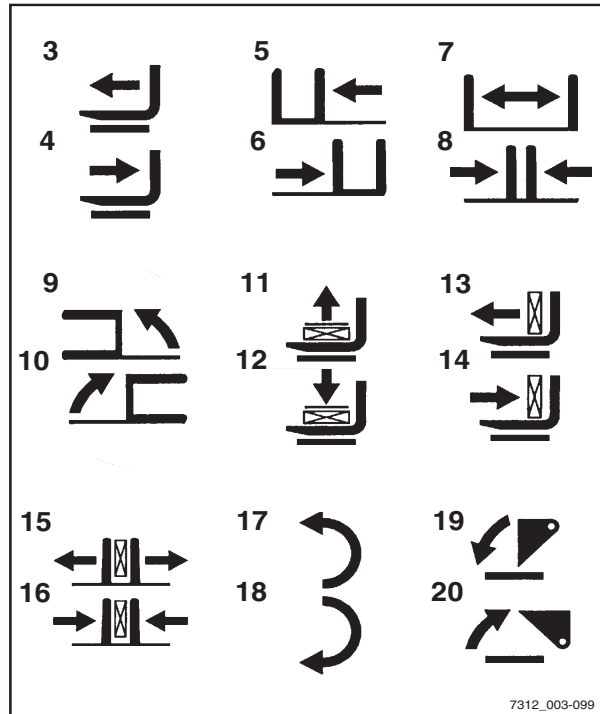

i NOTE

The pictograms shown correspond to the attachments fitted to this truck at the factory. If an attachment with other functions is fitted, the pictograms must be checked for the correct representation and changed if necessary.

– Contact the authorised service centre if required.

Controlling attachments using the triple mini-lever and the 5th function

i NOTE

For technical reasons, clamping attachments **must not** be controlled via the 5th function.

i NOTE

The "lift mast" 360° lever and operating levers (1) and (2) control four hydraulic functions. The designation "5th function" refers to the fact that the 5th hydraulic function can be controlled with the operating lever (1) by switching the functions using the function key (3).

The pictograms on the operating levers show the respective functions that are activated by these levers.

This essentially involves the following:

- Actuate the "5th function" function key (3) and move operating lever (1) towards (E).

The attachment moves in accordance with the pictogram in position (E).

- Actuate the "5th function" function key (3) and move operating lever (1) towards (F).

The attachment moves in accordance with the pictogram in position (F).

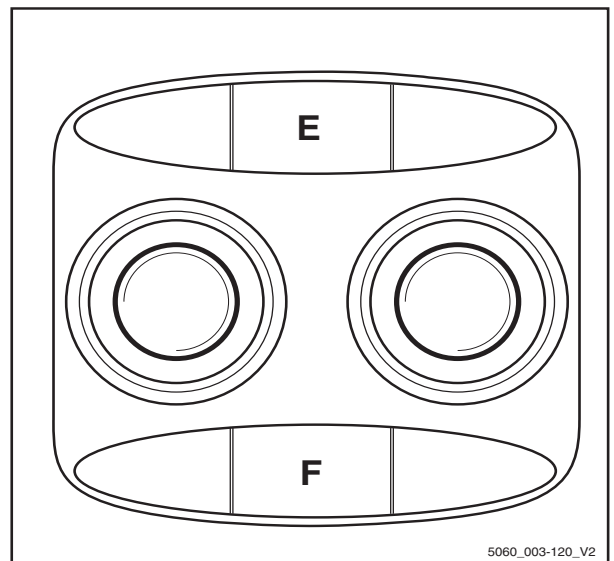
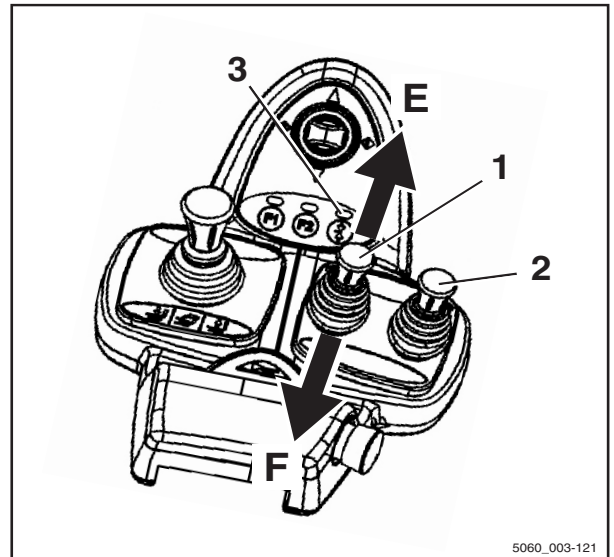

4 Operation

Attachments

– Note the following attachment functions and pictograms. ▷

1	Adjust fork arms: open
2	Adjust fork arms: close
3	Rotate to the left
4	Rotate to the right

i NOTE

The pictograms shown correspond to the attachments fitted to this truck at the factory. If an attachment with other functions is fitted, the pictograms must be checked for the correct representation and changed if necessary.

– Contact the authorised service centre if required.

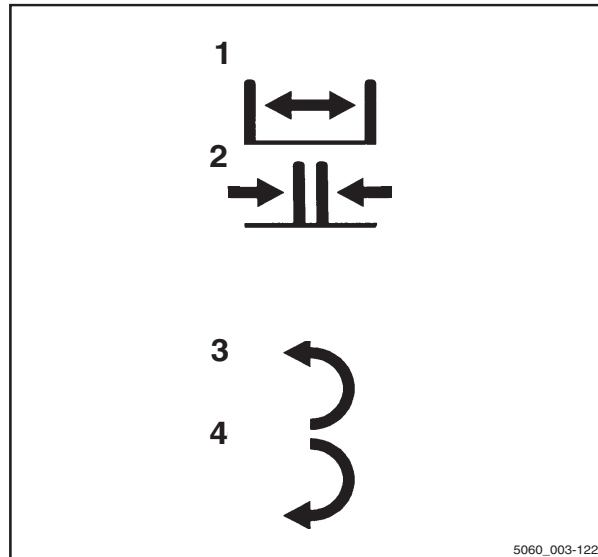

Controlling attachments using a quadruple mini-lever

The attachments (variant) are controlled in this version using operating levers (1) and (2).

The pictograms on the operating levers show the respective function that is activated by these levers.

This essentially involves the following:

- Move the operating lever (1) towards (A)

The attachment moves in the direction shown in pictogram (A).

- Move the operating lever (1) towards (B)

The attachment moves in the direction shown in pictogram (B).

- Move the operating lever (2) towards (C)

The attachment moves in the direction shown in pictogram (C).

- Move the operating lever (2) towards (D)

The attachment moves in the direction shown in pictogram (D).

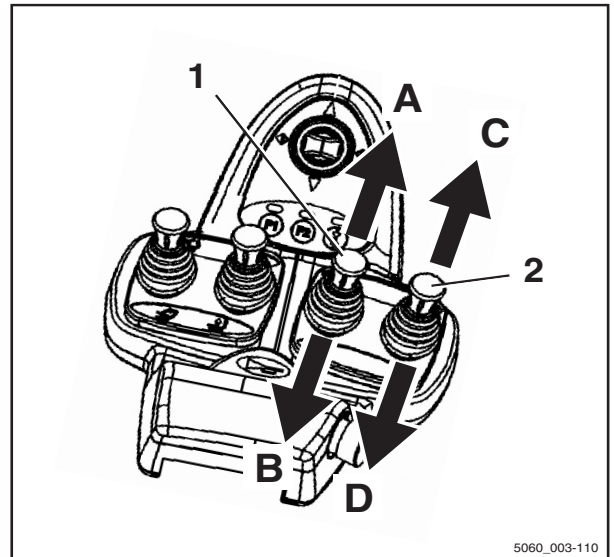

5060_003-110

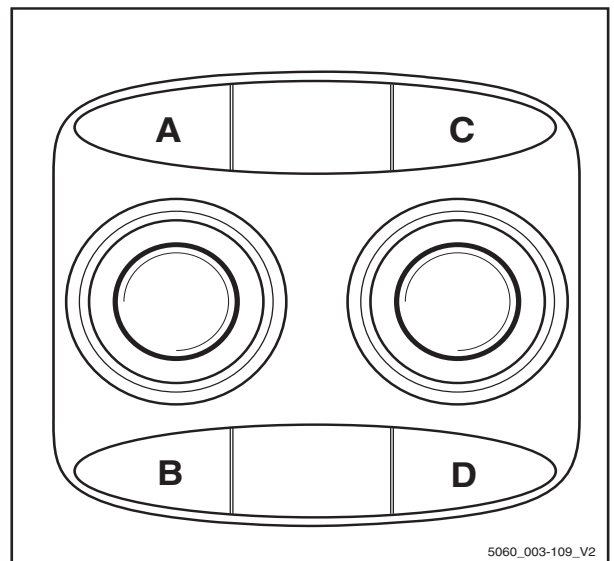

5060_003-109_V2

4 Operation

Attachments

– Note the following attachment functions and pictograms. ▷

3	Move sideshift frame or fork forwards
4	Move sideshift frame or fork backwards
5	Move sideshift to the left
6	Move sideshift to the right
7	Adjust fork arms: open
8	Adjust fork arms: close
9	Swivel lift mast or fork to the left
10	Swivel lift mast or fork to the right
11	Release load retainer
12	Clamp load retainer
13	Push off the load
14	Pull in the load
15	Open clamps
16	Close clamps
17	Rotate to the left
18	Rotate to the right
19	Tip shovel over
20	Tip shovel back

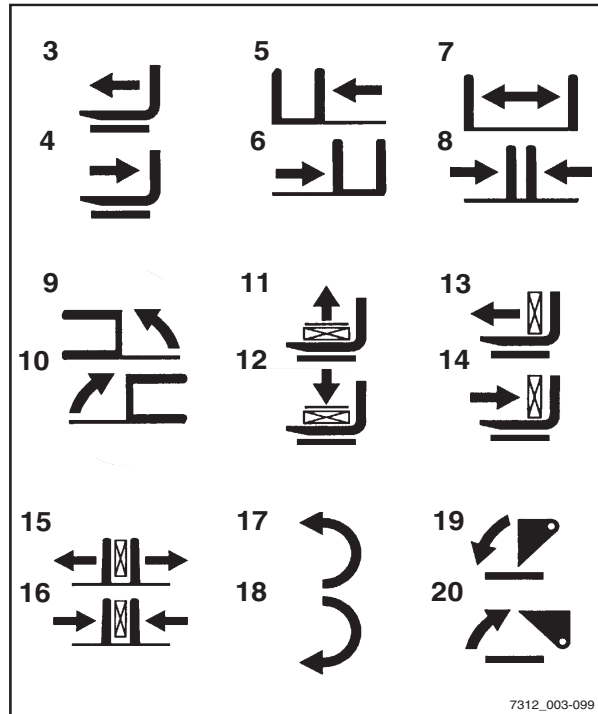

i NOTE

The pictograms shown correspond to the attachments fitted to this truck at the factory. If an attachment with other functions is fitted, the pictograms must be checked for the correct representation and changed if necessary.

– Contact the authorised service centre if required.

Controlling attachments using the quadruple mini-lever and the 5th function

NOTE

For technical reasons, clamping attachments **must not** be controlled via the 5th function.

NOTE

Operating levers (1) to (4) are used to control four hydraulic functions. The designation "5th function" refers to the fact that the 5th hydraulic function can be controlled with the operating lever (3) by switching the functions using the "5th function" function key (5).

The pictograms on the operating levers show the respective functions that are activated by these levers.

This essentially involves the following:

- Actuate the "5th function" function key (5) and move operating lever (3) towards (E).

The attachment moves in accordance with the pictogram in position (E).

- Actuate the "5th function" function key (5) and move operating lever (3) towards (F).

The attachment moves in accordance with the pictogram in position (F).

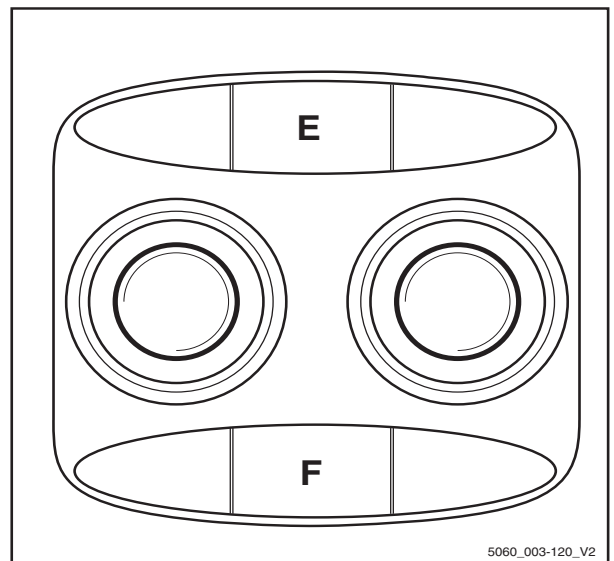
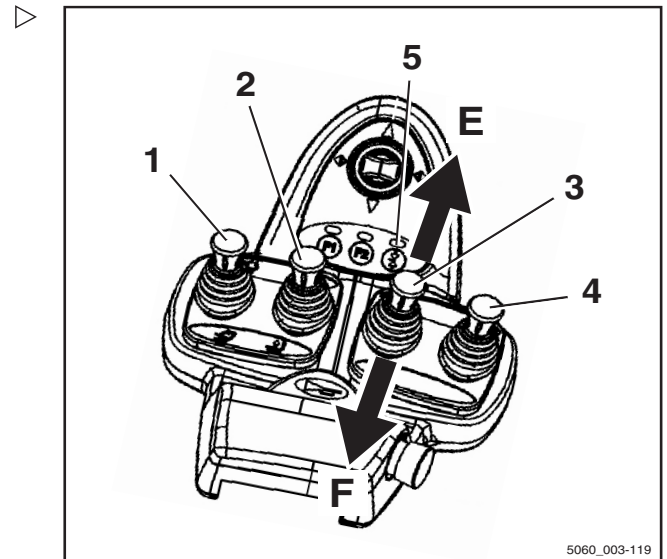

4 Operation

Attachments

- Note the following attachment functions and pictograms. ▷

1	Adjust fork arms: open
2	Adjust fork arms: close
3	Rotate to the left
4	Rotate to the right

i NOTE

The pictograms shown correspond to the attachments fitted to this truck at the factory. If an attachment with other functions is fitted, the pictograms must be checked for the correct representation and changed if necessary.

- Contact the authorised service centre if required.

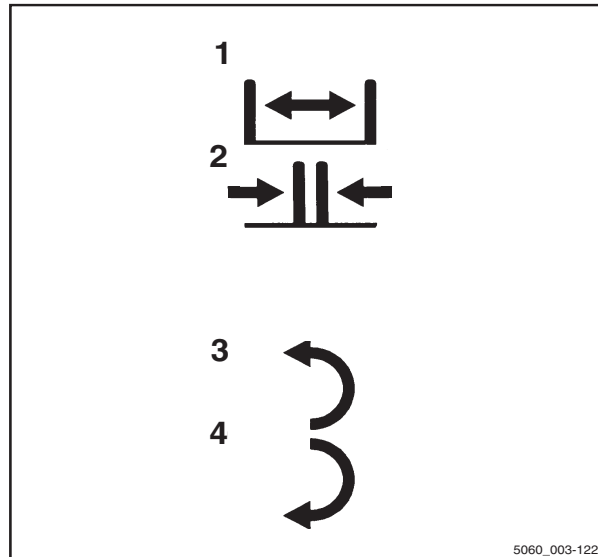

Controlling attachments using the Joystick 4Plus

In this version, the attachments (variant) are controlled via the Joystick 4Plus (1) and the slider (4). The adhesive label bearing the pictograms for the hydraulic functions (2) for the Joystick 4Plus (1) and the adhesive label (3) for the slider (4) are affixed at the designated points.

- If the adhesive labels become illegible or are not present, please contact your authorised service centre.
- Observe the pictograms for the attachment functions on the adhesive labels (2, 3).

The pictograms on the adhesive labels regarding operation of the Joystick 4Plus show the respective functions that are activated by the individual operating devices of the Joystick 4Plus.

The following applies:

- Move the Joystick 4Plus (1) in the direction of the arrow (A) or (B).

The attachment moves accordingly in the directions (A) or (B) as shown in the pictogram.

- Move the slider (4) in the direction of the arrow (C) or (D).

The attachment moves accordingly in the directions (C) or (D) as shown in the pictogram.

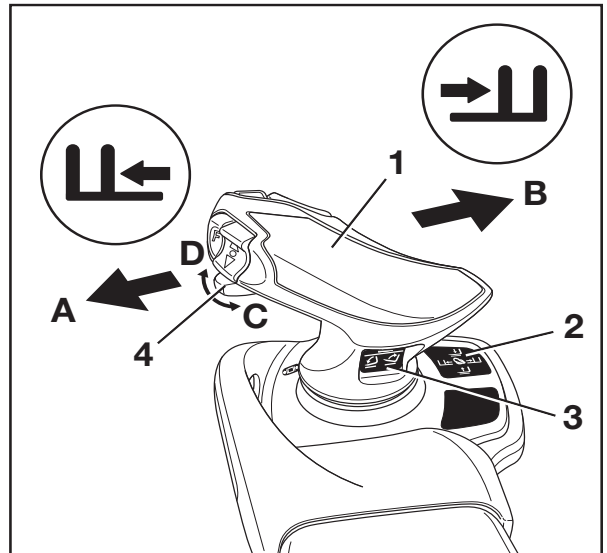

Pictogram	Attachment function
	Move side shift frame or fork forwards
	Move side shift frame or fork backwards
	Move sideshift to the left
	Move sideshift to the right
	Adjust fork arms: open
	Adjust fork arms: close
	Release load retainer
	Clamp load retainer
	Open clamps



4 Operation

Attachments

Picto-gram	Attachment function
	Close clamps
	Rotate to the left
	Rotate to the right
	Tip shovel over
	Tip shovel back

NOTE

The pictograms are affixed according to the attachment fitted at the factory. If an attachment with different functions is fitted, the authorised service centre must check that the pictograms bear the correct representation and must change them if necessary.

- For actuation of the clamp locking mechanism, see the section entitled "Clamp locking mechanism (variant)".

Controlling attachments with Joystick 4Plus and the 5th function

NOTE

For technical reasons, clamping attachments **must not** be controlled via the 5th function.

Use shift key "F" (4) and the Joystick 4Plus (2) and the horizontal rocker button (1) to control the "5th function".

The adhesive label bearing the pictograms for the hydraulic functions (3) for the Joystick 4Plus (2) and for the rocker button (1) is affixed at the designated point.

- If the adhesive label becomes illegible or is not present, please contact your authorised service centre.

The pictograms on the adhesive label regarding operation of the Joystick 4Plus show the respective functions that are activated by the individual operating devices of the Joystick 4Plus.

- Note the following attachment functions and pictograms.

	Operating device	Function of the attachment
1	Shift key "F" and Joystick 4Plus	Adjust fork arms: close/open
2	Shift key "F" and rocker button	Adjust fork: backwards/forwards
3	Shift key "F" and rocker button	Swivel lift mast or fork: left/right
4	Shift key "F" and rocker button	Additional fork carriage: lift/lower

The following applies:

- Press and hold shift key "F" (4).
- Move the Joystick 4Plus (2) in the direction (E) or (F).

The attachment moves accordingly in the directions (E) or (F) as shown in the pictogram.

- Push the rocker button (1) in the direction (G) or (H).

The attachment moves accordingly in the directions (G) or (H) as shown in the pictogram.

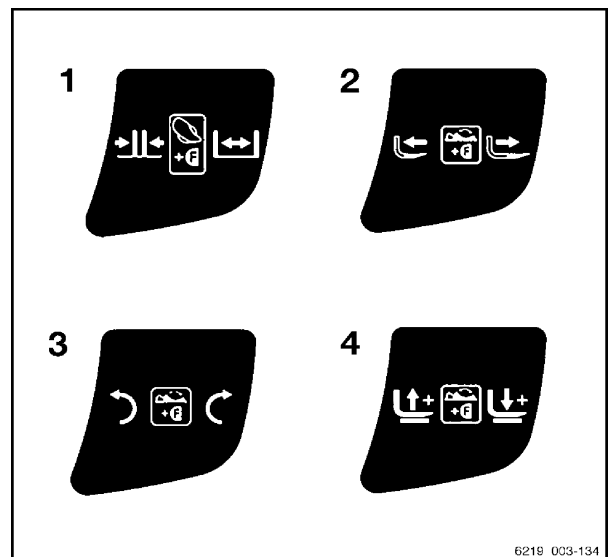
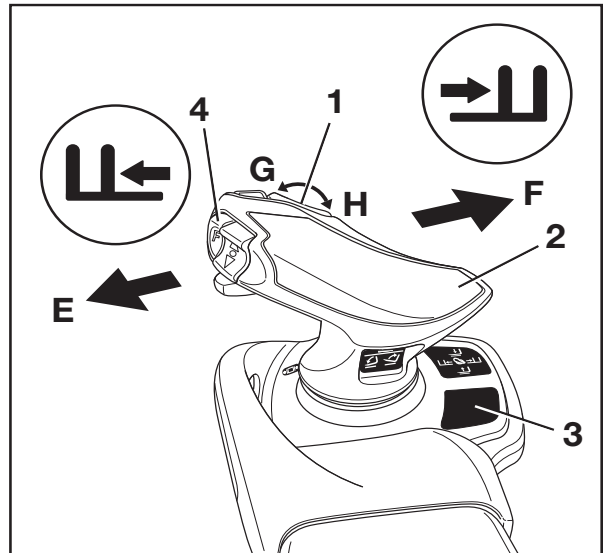



4

Operation

Attachments

- Release shift key "F" (4).

 **NOTE**

The pictograms are affixed according to the attachment fitted at the factory. If an attachment with different functions is fitted, the authorised service centre must check that the pictograms bear the correct representation and must change them if necessary.

Controlling the attachments with fingertip

The attachments (variant) are controlled in this version using the operating levers (1).

The pictograms on the operating levers always show the functions that are activated by that lever.

- Move operating lever (1) forwards.

The attachment moves in the direction of movement shown in the upper part of the pictogram.

- Move operating lever (1) backwards.

The attachment moves in the direction of movement shown in the lower part of the pictogram.

- Note the following attachment functions and pictograms.

2	Move side shift frame or forks forwards/backwards
3	Move sideshift to the left/to the right
4	Adjust fork arms: open/close
5	Swivel lift mast or forks to the left/to the right
6	Release/clamp load retainer
7	Push off/pull in load
8	Open/close clamps
9	Turn to the left/to the right
10	Tip shovel over/tip shovel back

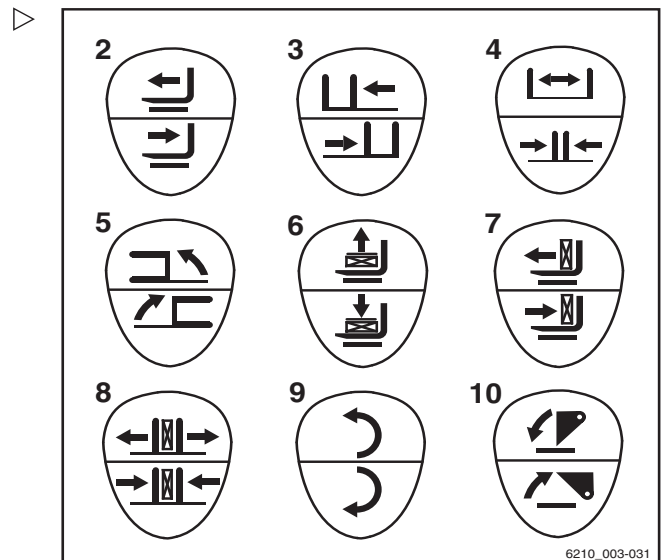
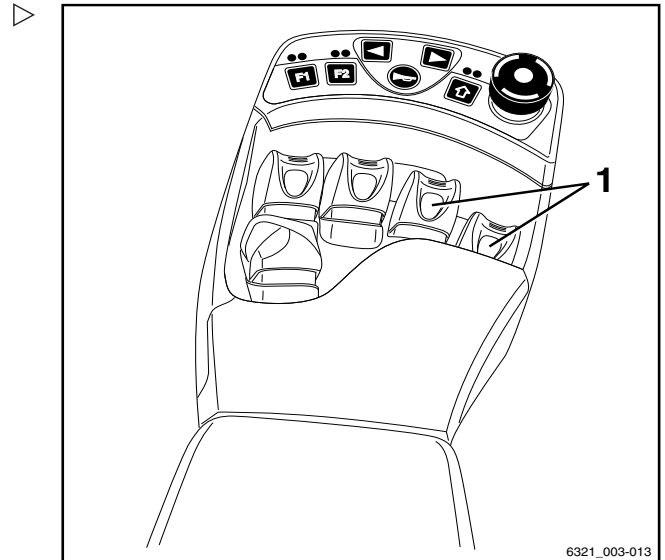

NOTE

The pictograms shown correspond to the attachments fitted to this truck at the factory. If an attachment with other functions is fitted, the pictograms must be checked for the correct representation and changed if necessary.

- Contact the authorised service centre if required.

4

Operation

Attachments

Controlling attachments with fingertip and the 5th function

i NOTE

For technical reasons, clamping attachments **must not** be controlled via the 5th function.

i NOTE

The designation "5th function" refers to the fact that the four operating levers control four functions, while the "5th function" can be controlled by switching functions.

The attachments (variant) are controlled using the operating levers (1).

You can also use the switch (2) to switch functions, in which case the corresponding operating lever controls the "5th function".

The pictogram (3) behind the operating lever shows in the upper and lower parts the function that is activated with this lever.

The meanings are as follows:

- Move operating lever forwards.

The attachment moves in the direction of movement shown in the upper part of the pictogram.

- Move operating lever back.

The attachment moves in the direction of movement shown in the lower part of the pictogram.

- Actuate the switch (2).

The additional function of the attachment is activated/deactivated and can be controlled as the "5th function" using the operating lever.

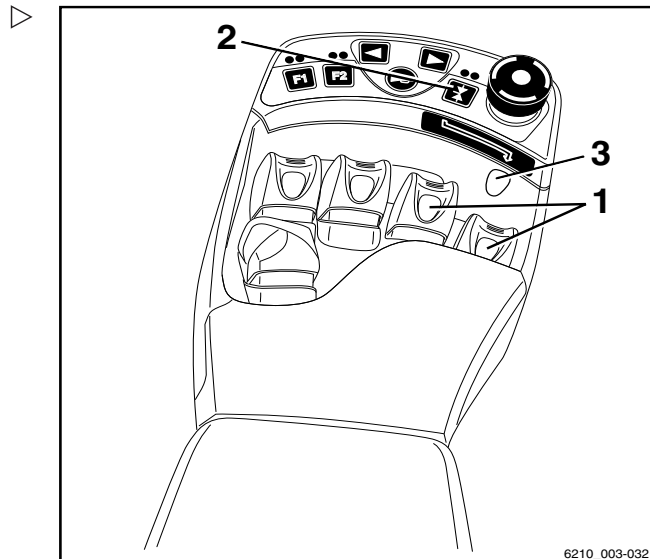

6210_003-032

Operation

4

Attachments

- Press the function key (4).

i NOTE

The arrow (5) under the function key indicates which operating lever is equipped with the "5th function".

The "5th function" is switched to the 3rd operating lever; see adhesive label (6).

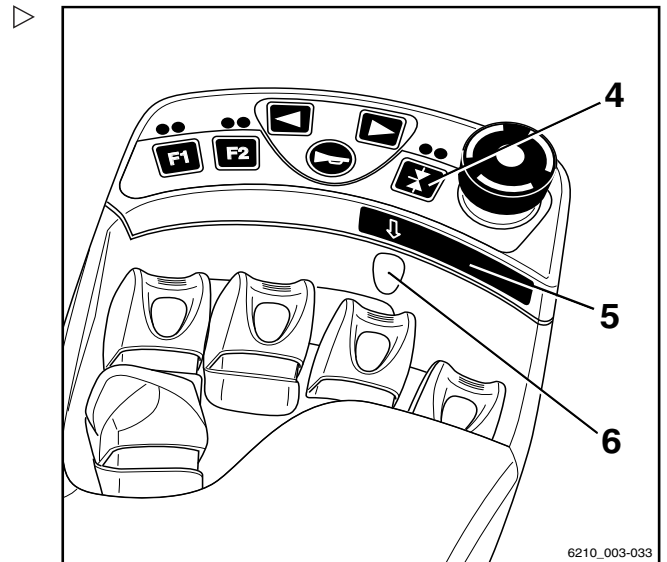

- Press the function key (7).

i NOTE

The arrow (8) under the function key indicates which operating lever is equipped with the "5th function".

The "5th function" is switched to the 4th operating lever; see adhesive label (9).

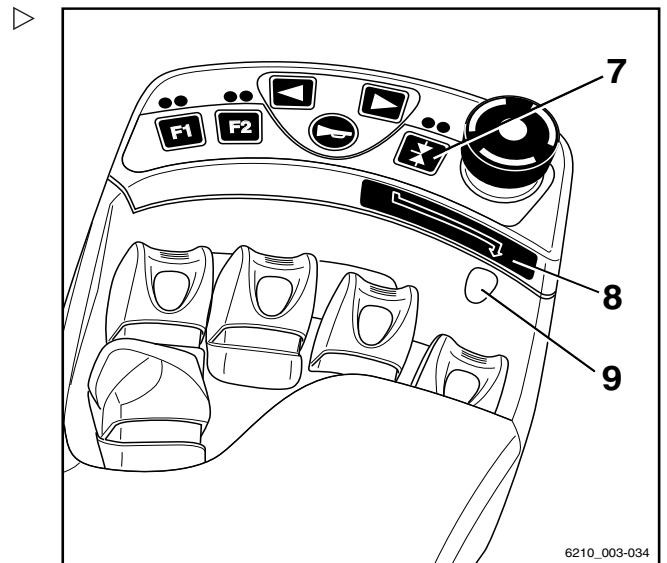

i NOTE

The movement/action of this "5th function" can be found in the operating instructions of the fitted attachment.

i NOTE

The pictograms are applied depending on the pre-assembled attachment. If an attachment with other functions is fitted, the pictograms must be checked for the correct representation and changed if necessary.

- Contact the authorised service centre if required.

4 Operation

Attachments

– Note the following attachment functions and pictograms.

10	Move side shift frame or fork forwards/backwards
11	Move sideshift to the left/right
12	Adjust fork arms: open/close
13	Swivel lift mast or fork to the left/right
14	Release/clamp load retainer
15	Push off/pull in load
16	Turn to the left/right
17	Tip shovel over/tip shovel back

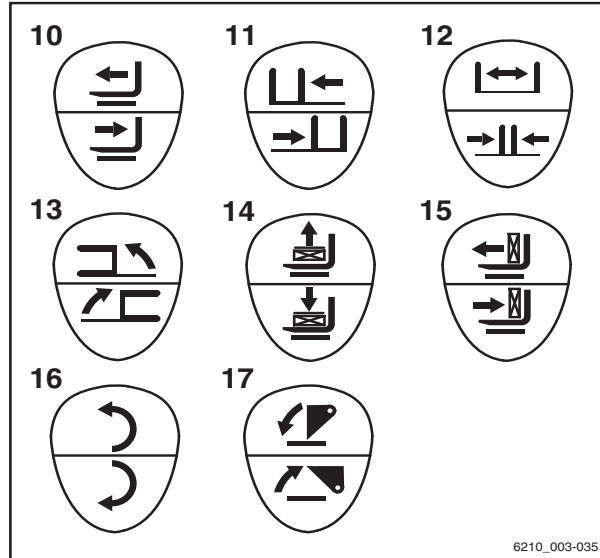

Clamp locking mechanism (variant)

This truck can be fitted with a clamp locking mechanism as a variant. This clamp locking mechanism prevents the clamp from opening unintentionally if the operating function is inadvertently triggered.

⚠ DANGER

There is a risk of fatal injury from falling loads if the correct function of the clamp locking mechanism is not guaranteed!

If other attachments are used on this truck in addition to the clamp, make sure that the clamp locking mechanism function is reassigned to the corresponding operating device every time the clamp is reassembled; see the chapter entitled "Fitting attachments".

- Make sure that the additional clamp locking mechanism function is available.

Multi-lever

- Press and hold the (2) button to release the clamp locking mechanism.

NOTE

The hydraulic function for opening the clamp is only available if the button is pressed. After releasing the button, the clamp locking mechanism is automatically reactivated.

- To release the clamp locking mechanism, push the operating lever (1) forwards.

It is not necessary to release the clamp locking mechanism in order to close the clamp.

- To close the clamp, pull the operating lever (1) backwards.

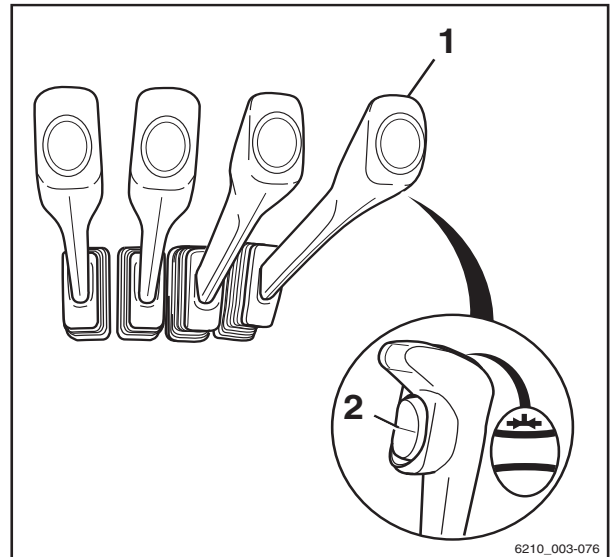

6210_003-076

Double mini-lever

- To release the clamp locking mechanism, push the operating lever (1) forwards.

The LED for button "F2" (2) lights up as long as the clamp locking mechanism is released.

NOTE

The hydraulic function for opening the clamp is available for one second after the clamp locking mechanism is released. After one second, the clamp locking mechanism is automatically reactivated.

- To open the clamp, push the operating lever (1) forwards again.

It is not necessary to release the clamp locking mechanism in order to close the clamp.

- To close the clamp, pull the operating lever (1) backwards.

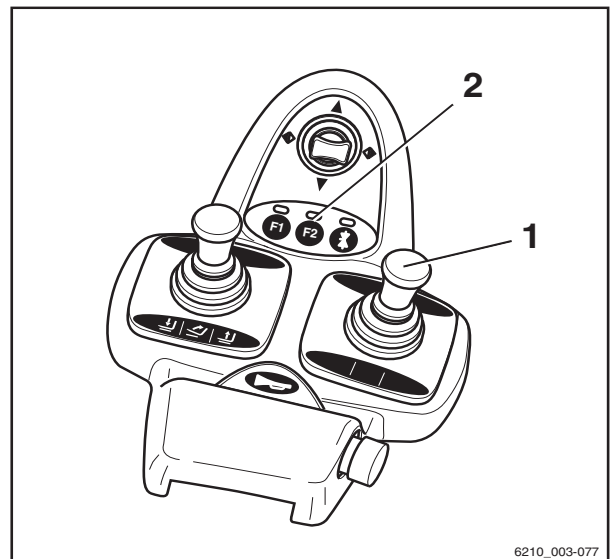

6210_003-077

4 Operation

Attachments

Triple mini-lever

- To release the clamp locking mechanism, push the operating lever (1) forwards.

The LED for button "F2" (2) lights up as long as the clamp locking mechanism is released.

i NOTE

The hydraulic function for opening the clamp is available for one second after the clamp locking mechanism is released. After one second, the clamp locking mechanism is automatically reactivated.

- To open the clamp, push the operating lever (1) forwards again.

It is not necessary to release the clamp locking mechanism in order to close the clamp.

- To close the clamp, pull the operating lever (1) backwards.

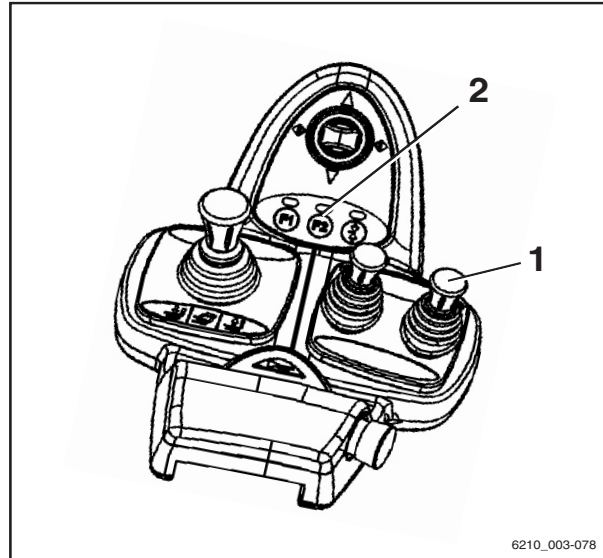

Quadruple mini-lever

- To release the clamp locking mechanism, push the operating lever (1) forwards.

The LED for button "F2" (2) lights up as long as the clamp locking mechanism is released.

i NOTE

The hydraulic function for opening the clamp is available for one second after the clamp locking mechanism is released. After one second, the clamp locking mechanism is automatically reactivated.

- To open the clamp, push the operating lever (1) forwards again.

It is not necessary to release the clamp locking mechanism in order to close the clamp.

- To close the clamp, pull the operating lever (1) backwards.

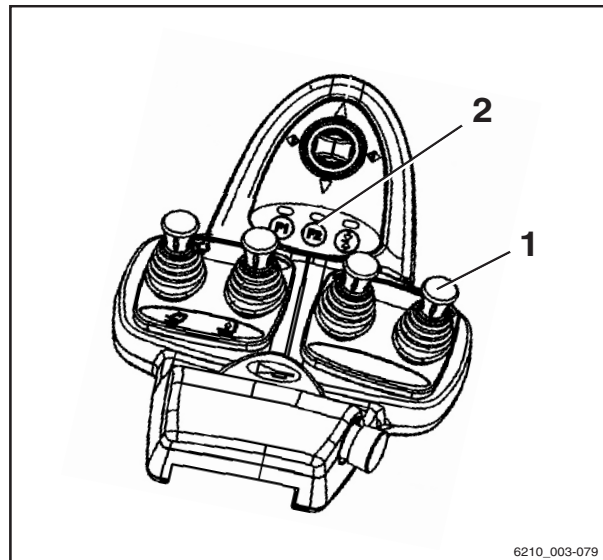

Joystick 4Plus

- To open the clamp locking mechanism, press and hold the shift button "F"(3).
- While doing so, move the horizontal rocker button (1) to the left.
- Keep the shift button "F" (3) pressed down and move the horizontal rocker button (1) back to the neutral position.

The LED (2) lights up.

- While holding down the shift button "F", move the horizontal rocker button (1) to the left again within 1 second.

The LED (2) lights up as long as the clamp locking mechanism is released.

 **NOTE**

The hydraulic function for opening the clamp is available for one second after the clamp locking mechanism is released. After one second, the clamp locking mechanism is automatically reactivated.

It is not necessary to release the clamp locking mechanism in order to close the clamp.

- To close the clamp locking mechanism, press and hold the shift button "F"(3).
- While doing so, move the horizontal rocker button (1) to the right.

The clamp closes.

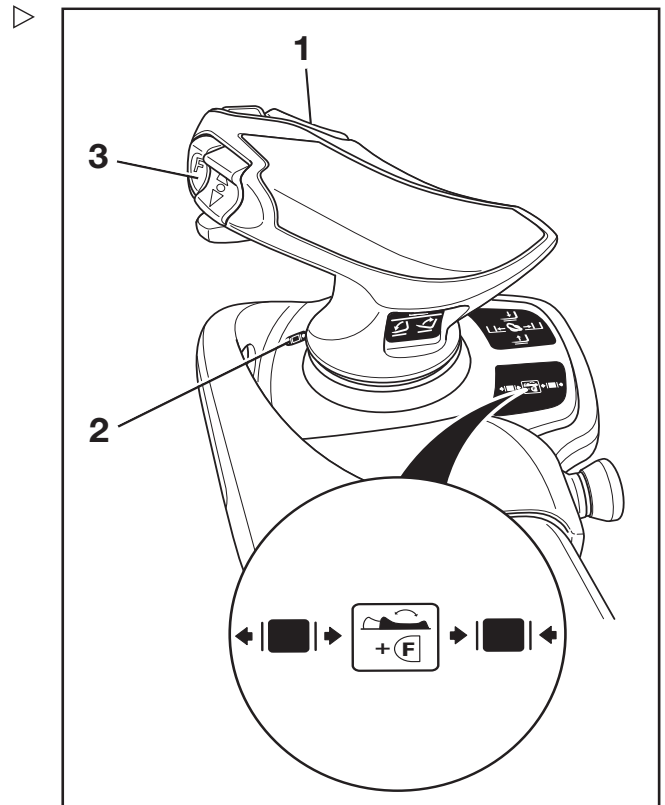

4 Operation

Attachments

Fingertip switch

- To release the clamp locking mechanism, push the operating lever (1) forwards.

The LED for button "F2" (2) lights up as long as the clamp locking mechanism is released.

i NOTE

The hydraulic function for opening the clamp is available for one second after the clamp locking mechanism is released. After one second, the clamp locking mechanism is automatically reactivated.

- To open the clamp, push the operating lever (1) forwards again.

It is not necessary to release the clamp locking mechanism in order to close the clamp.

- To close the clamp, pull the operating lever (1) backwards.

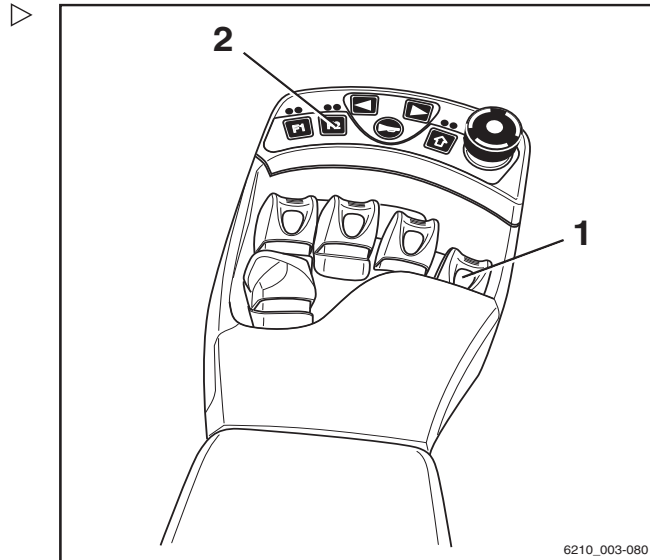

Taking up a load using attachments

⚠ WARNING

Risk of accidents!

Attachments may only be used for their intended purpose as described in the relevant operating instructions.

Drivers must be instructed in the handling of the attachments.

⚠ WARNING

Risk of accidents!

Loads may only be picked up and transported with attachments if they are securely attached. Where necessary, loads should also be secured against slipping, rolling, falling over, swinging or tipping over. Note that any change to the position of the load's centre of gravity will affect the stability of the forklift truck.

Check the capacity rating plates for the attachments or combination of attachments.

- The rating plates show the permissible values for:

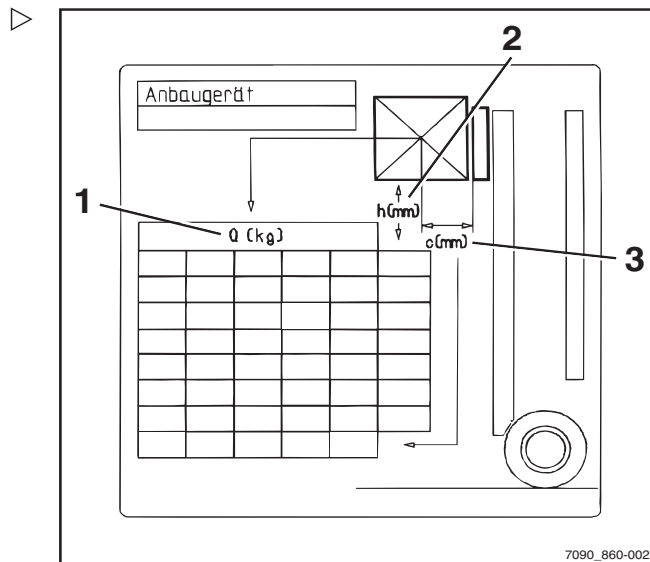

- Load capacity Q (kg) (1)
- Lift height h (mm) (2)
- Load distance C (mm) (3)

Auxiliary equipment

Switching the lighting on and off

Driving lights

- To switch on the parking light, press the button (1). ▷

The front sidelights and the rear lights light up.

- To switch on the headlights, press the button (1) again.

The headlights light up in addition to the parking light.

- To switch off the driving lights, press the button (1) again.

The driving lights go out.

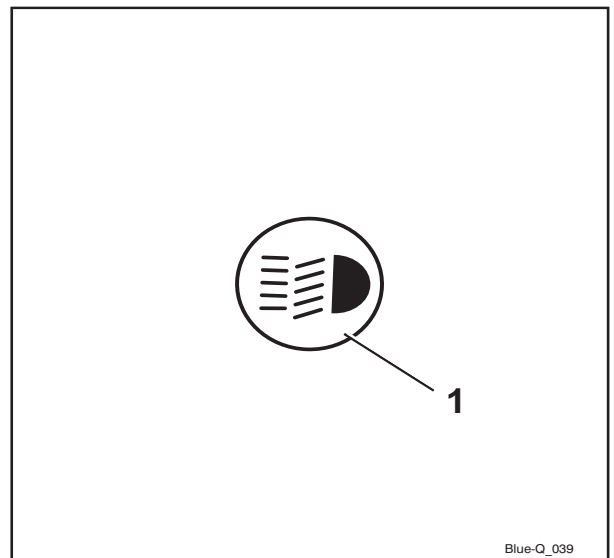

Working spotlights

- To switch on the working spotlights (front and rear), press the button (1). ▷

The working spotlights light up.

- To switch off the working spotlights, press the button (1) again.

The working spotlights go out.

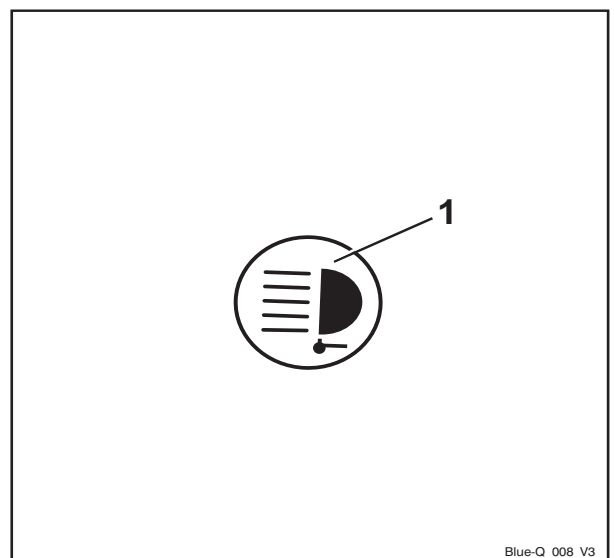

NOTE

When the working spotlights are switched on in trucks with StVZO (German Road Traffic Licensing Regulations) equipment (variant), the following lighting devices on the truck are also activated:

- Rear lights
- Sidelights

4

Operation

Auxiliary equipment

Switching the working spotlight for reverse travel on and off

The working spotlight for reverse travel is attached to the overhead guard at the rear. It provides optimal illumination of the roadway if the truck is travelling in reverse.

- Press the  softkey (1).

The  symbol (2) is displayed. The rear working spotlight does not yet illuminate.

- Set the drive direction to "Reverse".

The rear working spotlight illuminates.

 **NOTE**

If the drive direction is set to "Forwards", the rear working spotlight goes out.

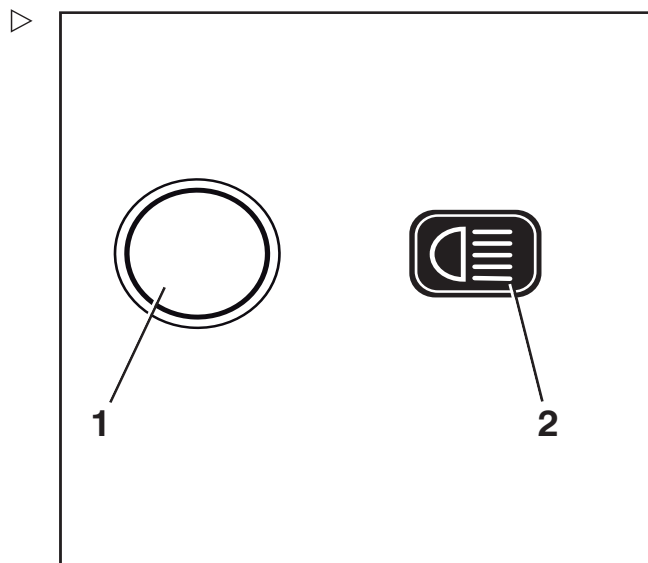

Switching the rotating beacon on and off

- Press the Softkey  (1) to switch on the rotating beacon.

The rotating beacon is switched on. The symbol  is displayed.

- To switch off the rotating beacon, press the Softkey .

The rotating beacon goes out. The symbol  (2) is displayed.

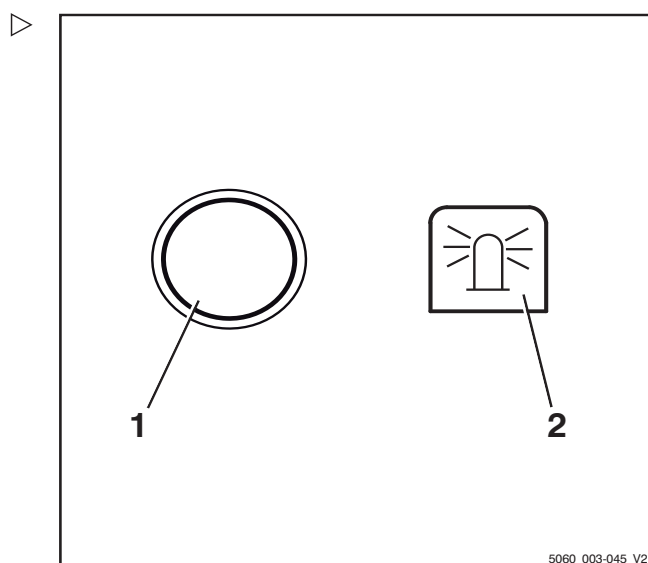

5060_003-045_V2

Switching the hazard warning system on and off

- To switch on the hazard warning system, press the button (1).

All turn indicators and indicator lights (2) flash.

- To switch off the hazard warning system, press the button (1) again.

The hazard warning system goes out.

 **NOTE**

To switch on the hazard warning system without the key switch being switched on, press and hold the button for three seconds.

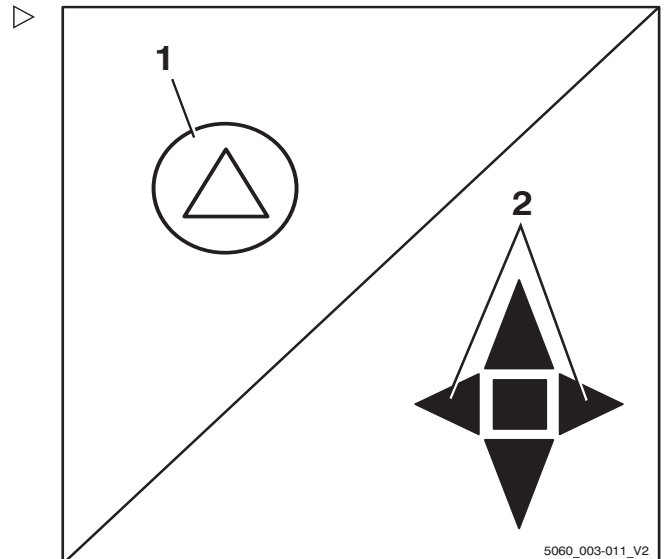

Switching the turn indicators on and off

Mini-lever version

- Switch on the turn indicators by moving the cross lever of the drive direction/turn indicator (1) to the left or to the right.

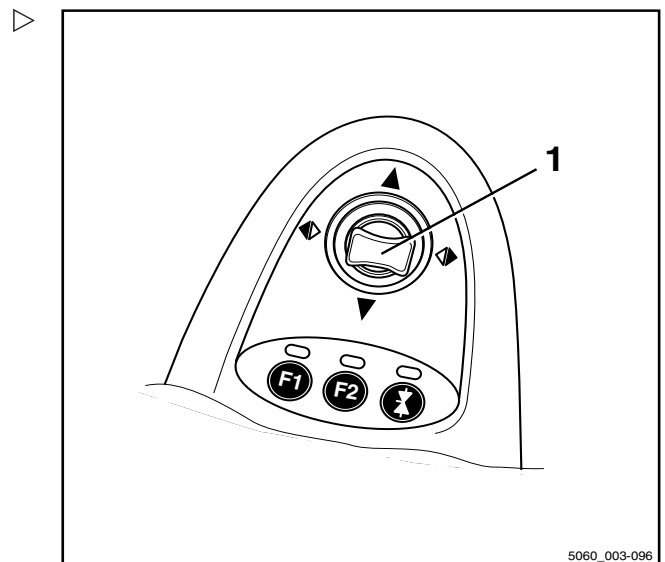

4 Operation

Auxiliary equipment

The turn indicators and the corresponding turn indicator displays (2) or (3) flash. ▷

- Switch off the turn indicators by moving the cross lever to the centre position.

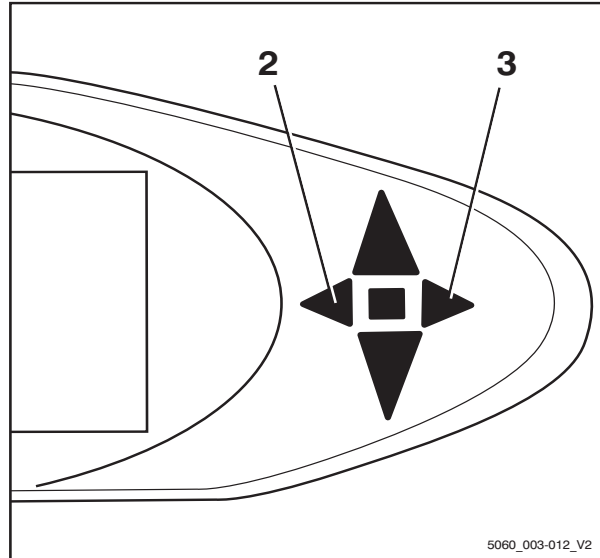

Fingertip version

- Switch on the turn indicators by moving the corresponding turn indicator button (1) to the left or to the right. ▷
- Switch off the turn indicators by actuating the other turn indicator button.

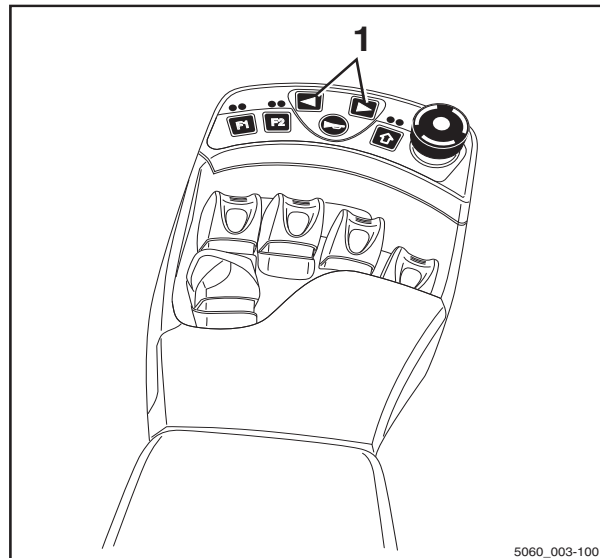

Mini-console version

- Switch on the turn indicators by moving the turn indicator switch (1) to the left or to the right. ▷

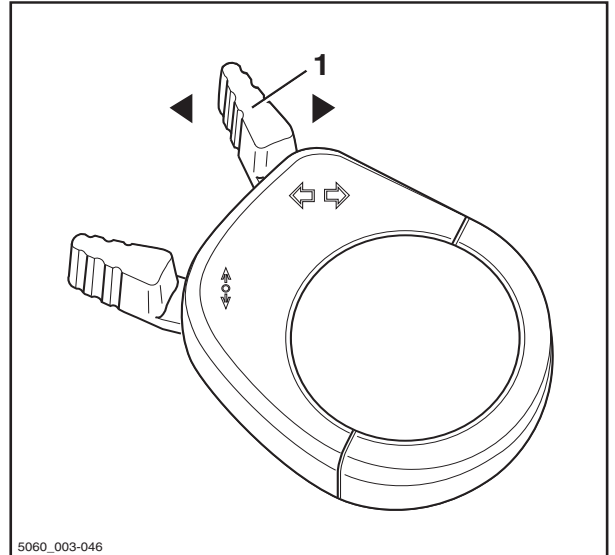

The turn indicators and the corresponding turn indicator displays (2) or (3) flash. ▷

- Switch off the turn indicators by moving the turn indicator switch to the centre position.

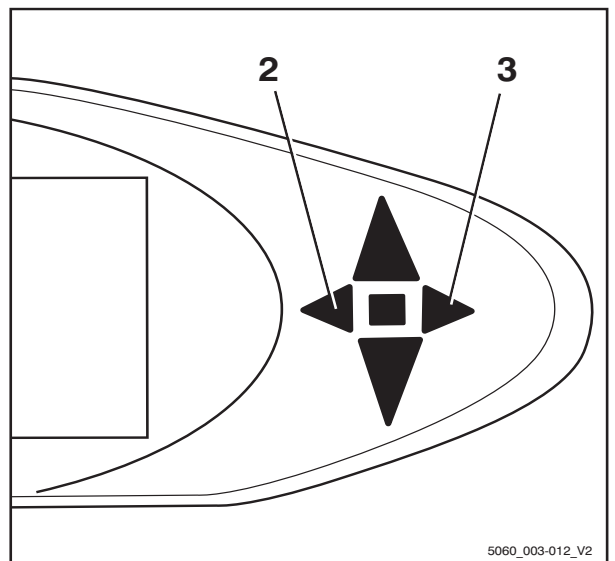

Auxiliary equipment

Switching the double working spotlights on and off.

The double working spotlights are fitted up on the front right and left on the overhead guard. Each double working spotlight consists of an upper working spotlight (2) and a lower working spotlight (3). The upper working spotlight illuminates the working area at great lift heights, the lower working spotlight illuminates the working area directly in front of the truck.

Depending on the equipment, the upper working spotlights can be switched on/off automatically or manually.

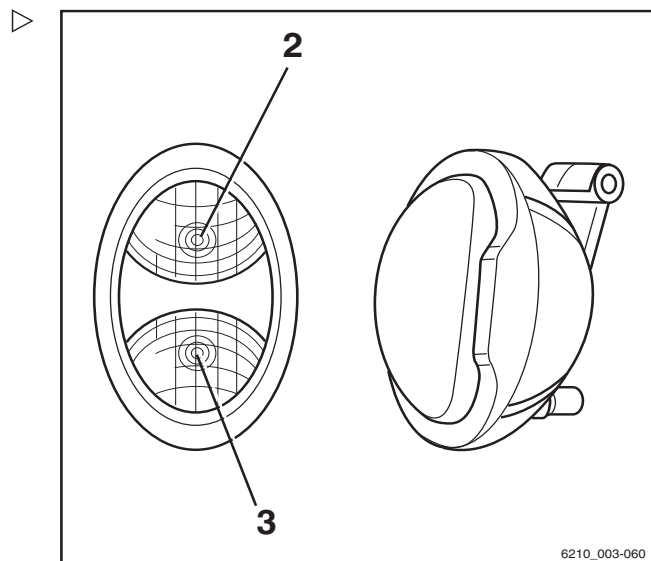

Switching the upper working spotlights on/off manually

i NOTE

The upper working spotlights can be switched on/off independently of the lower working spotlights. For information about switching on the lower working spotlights, see the section entitled "Switching the lighting on and off".

i NOTE

This function is not available if the truck is equipped with rear window heating.

- Turn the key switch to position "I".

- Press Softkey  (1) to switch on the working spotlights.

The working spotlights are switched on. The  symbol is displayed.

- Press Softkey  to switch off the working spotlights.

The working spotlights are switched off. The  symbol is displayed.

Switching the upper working spotlights on/off automatically

- Turn the key switch to position "I".
- For information about switching on the working spotlights, see the chapter entitled "Switching the lighting on and off".

The lower working spotlights light up.

The upper working spotlights are switched on automatically when the lift mast is lifted for a period of at least two seconds.

NOTE

During these two seconds, a maximum of two lifts can be executed to prevent the working spotlights from switching on each time a precise adjustment is made. If more lifts are carried out during this time, the upper working spotlights will remain switched off.

NOTE

The upper working spotlights are switched off automatically when the truck is driven for longer than one second at a speed faster than 2.1 km/h.

Lift-height-controlled switching on/off of the upper working spotlights

NOTE

This equipment is available only if a proximity switch is fitted to the lift mast to record a particular lift height of the fork carriage on the lift mast.

- Turn the key switch to position "I".

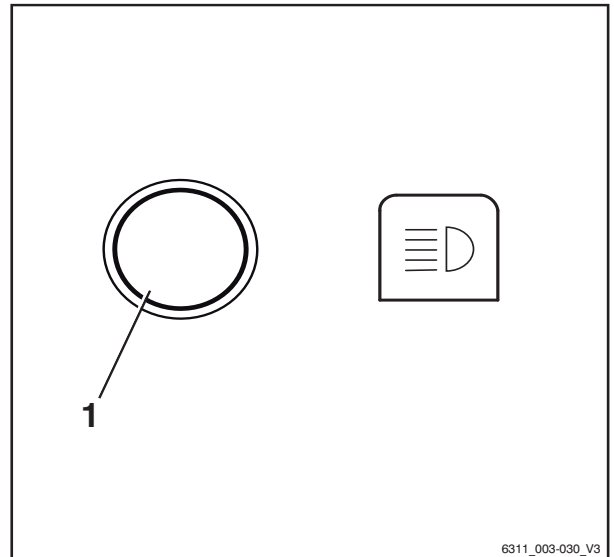

4

Operation

Auxiliary equipment

- Switch on the working spotlights.

The lower working spotlights light up.

The upper working spotlights are switched on by the proximity switch when the fork carriage reaches or exceeds the preset lift height.

The upper working spotlights are switched off by the proximity switch when the fork carriage falls below the preset lift height again.

⚠ CAUTION

Possible component damage caused by collision if the proximity switch is set incorrectly.

- The proximity switch may be adjusted by trained personnel.
- If necessary, inform the authorised service centre.

STILL SafetyLight (variant)



⚠ WARNING

Danger of damage to eyes from looking into the STILL SafetyLight.

Do not look into the STILL SafetyLight.

The STILL SafetyLight is a visual warning unit designed to enable early detection of trucks in driving areas with low visibility (such as drive lanes, high racks), as well as at blind junctions. The STILL SafetyLight is mounted on a support on the overhead guard such that it is not affected by jolts and vibrations. The STILL SafetyLight projects one or more light-blue light spots in front of or behind the truck and thus warns others about the approaching truck. Several light spots are projected as a chase light. The chase light indicates the location of the truck with its direction of travel.

Depending on the configuration of the truck, the STILL SafetyLight automatically switches itself on when the truck is moving. The STILL SafetyLight can also be switched on and off on the display-operating unit.

- To do so, press the corresponding button.

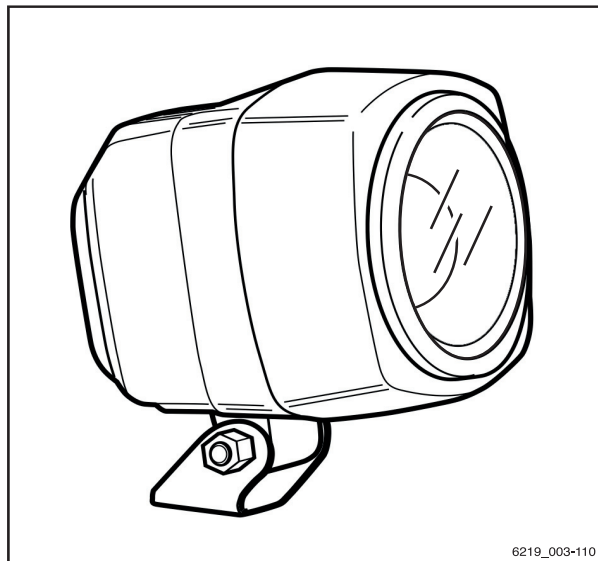

6219_003-110

i NOTE

If the truck is to be operated on public roads, the STILL SafetyLight must be switched off.

Operating the windscreen wiper/washer

- Push button (1) to actuate the front windscreen wiper/washer (variant)
- Push button (2) to actuate the rear windscreen wiper/washer (variant)

Repeated pressing of the respective button switches between the operating stages in the sequence specified shown below.

Button actuation	Operating stage
	Off
1st time	on
2nd time	Interval
3rd time + hold	Washer
4th time	Off

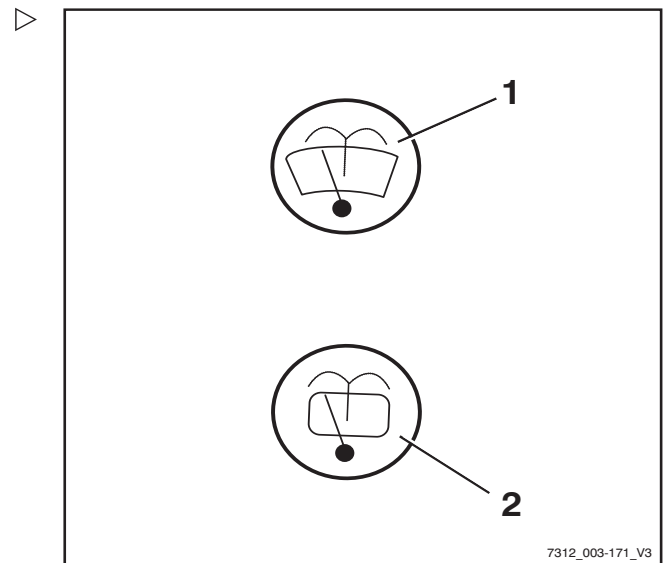

Filling the washer system

- Open the filler cap (1) of the washer system (variant).
- Fill the washer reservoir (2) with washer fluid containing anti-freeze, according to the maintenance data table; see ⇒ Chapter "Maintenance data table", P. 5-387.

⚠ CAUTION

Components may become damaged due to the effects of frost!

Water expands when it freezes. If there is no anti-freeze in the washer system (variant), the system may become damaged due to the accumulation of ice in freezing conditions.

- Always use washer fluid containing anti-freeze.

- Close the filler cap.
- Operate washer system until washer fluid is discharged from the spray nozzles.

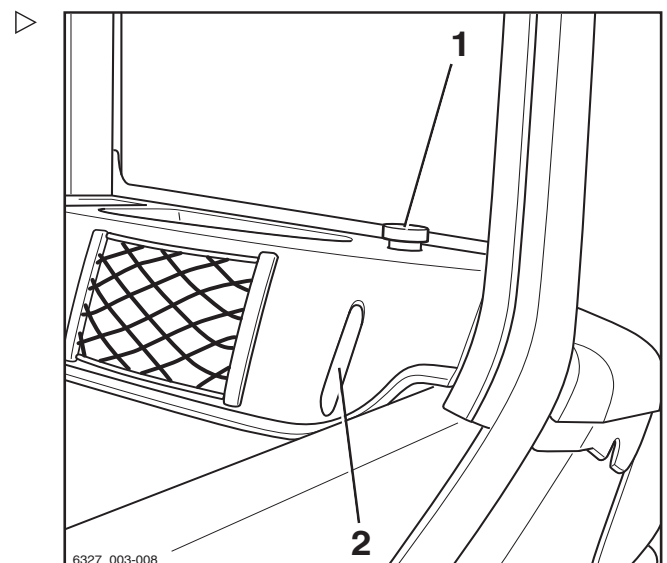



Auxiliary equipment

FleetManager (variant)

FleetManager is an equipment variant and can be fitted to the truck in different versions. The description and operation information can be found in the separate operating instructions for the corresponding FleetManager versions.

Shock recognition (variant)

The shock recognition is an equipment variant of the FleetManager (variant) in which an acceleration sensor is installed in the truck. The acceleration sensor records data arising from rapid accelerations or decelerations of the truck, e.g. in the event of an accident. This data can be electronically read out and evaluated.

- If you have any questions, please contact your authorised service centre.

Driver restraint systems (variants)

Different driver restraint systems are available as variants for this truck. The description and operation for these systems can be found in the separate "Driver restraint systems" operating instructions.

Ceiling sensor (variant)

Description

The ceiling sensor (1) on the overhead guard is an assistance system that automatically reduces the driving speed of the truck within halls. However, this assistance system does not release the driver from the responsibility of observing the speed limits on company premises.

Depending on the system setting, the ceiling sensor can detect overhead structures above the truck at a height of 2 m to 24 m above the sensor.

Operating the ceiling sensor system

The drivers are to be instructed on the use of the ceiling sensor system by the operating company.

When the driver enters a hall for the first time after starting work, he must be certain that the ceiling sensor system is functioning correctly. Despite the ceiling sensor system being installed, the driver must also check the speed indicator on the display-operating unit on a regular basis to ensure that he does not exceed the maximum speed permitted for the environment.

- **Entering a hall**

The ceiling detector system automatically detects whether the truck enters a hall. The system then automatically slows the truck to the maximum speed that is set for the hall.

- **Leaving a hall**

If the truck leaves the hall again, the ceiling detector system enables the maximum speed set for areas outside the hall. Due to the range of the sensor, this may not happen until the truck is a few metres away from the hall exit. Before the truck is able to accelerate to the maximum speed permitted for outdoor areas, the speed limitation must still be unlocked. To do this, release the

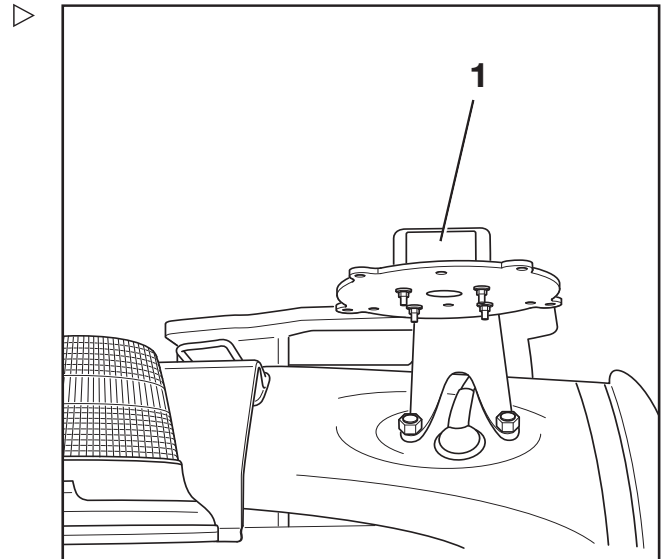



Auxiliary equipment

accelerator briefly and then operate the accelerator again.

- **Switching on the truck in a hall**

If the truck is switched on inside a hall, the ceiling detector system detects the hall ceiling and reduces the driving speed to the maximum speed that is set for halls.

Possible limitations for object recognition

- If the truck moves under larger overhead structures outdoors, e.g. a pedestrian bridge, the ceiling sensor system may interpret this overhead structure to be a hall ceiling and reduce the maximum speed.
- In rare cases, it may occur that the ceiling sensor system does not recognize a ceiling and does not then reduce the speed. This can happen if the signals from the ceiling sensor are insufficiently reflected due to the ceiling geometry; for example, if there are large window areas at a 45° angle.

In these cases, the sensitivity and the range of the ceiling sensor system must be adjusted. For more information, refer to the next chapter.

Changing the sensor settings

The ceiling sensor system is supplied by STILL with the following factory settings:

Sensitivity: **High**

Ceiling height: **24 m**

- Pull out the connecting cable from the sensor.

Operation

4

Auxiliary equipment

- On the underside of the assembly baseplate on the overhead guard, loosen the four nuts (1) on the sensor. ▷
- Carefully remove the sensor.

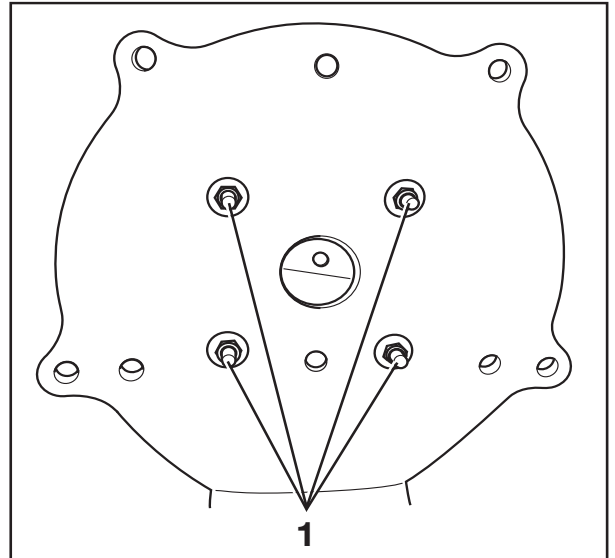

- Using the supplied key (2), open the sensor housing to gain access to the DIP switches. ▷

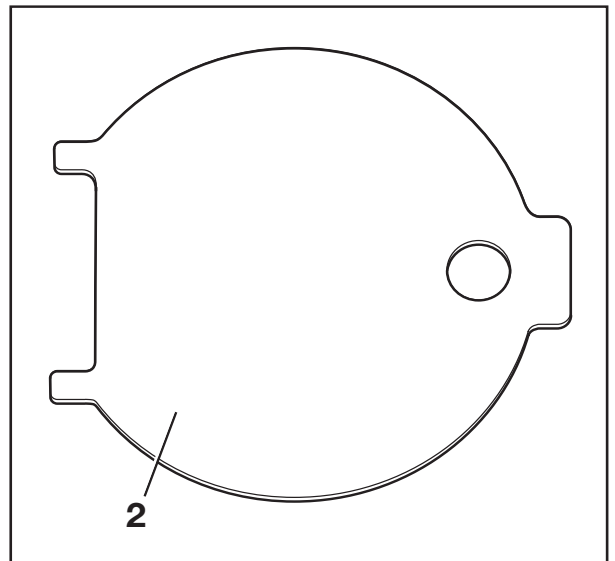

4 Operation

Auxiliary equipment

- Using the DIP switches "1" to "5" (3), adjust the range and the sensitivity of the sensor. The DIP switches can be adjusted using a small screwdriver.

CAUTION

The settings for DIP switches "6" to "8" are the factory settings of the manufacturer. They must **not** be changed!

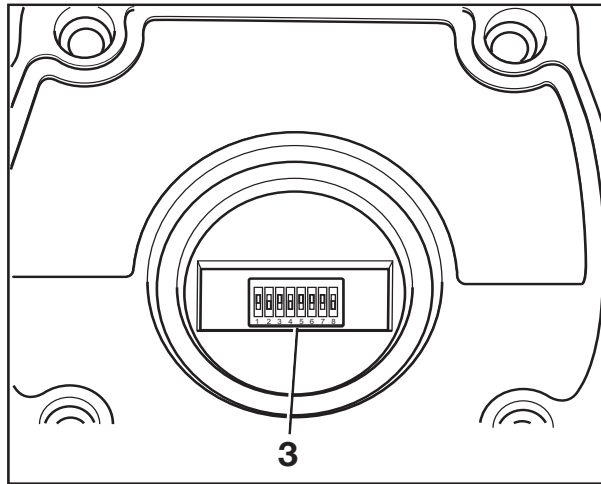

Factory settings of the manufacturer - do not change

DIP switch		
6	7	8
1	1	0

The possible settings for DIP switches "1" to "5" are shown in the following tables:

DIP switch			Range
1	2	3	
0	0	0	2 m
0	0	1	3 m
0	1	0	4 m
0	1	1	6 m
1	0	0	8 m
1	0	1	12 m
1	1	0	16 m
1	1	1	24 m

4	5	Sensitivity
0	0	Very high
0	1	High
1	0	Medium
1	1	Low

The sensor has different beam angles depending on the combination of range and



sensitivity that has been set. See the following table:

Sensitivity	Range	Beam angle
Low (1)	2 m	22.5°
	4 m	22.5°
	8 m	20°
	16 m	15°
	24 m	5°
Medium (2)	2 m	35°
	4 m	30°
	8 m	25°
	16 m	22.5°
	24 m	10°

Sensitivity	Range	Beam angle
High (3)	2 m	42°
	4 m	33°
	8 m	22.5°
	16 m	20°
	24 m	15°
Very high (4)	2 m	45°
	4 m	43°
	8 m	30°
	16 m	22.5°
	24 m	18°

4

Operation

Auxiliary equipment

Representation of the beam angle depending on the sensitivity of the sensor that has been set, from (1) "low" to (4) "very high".

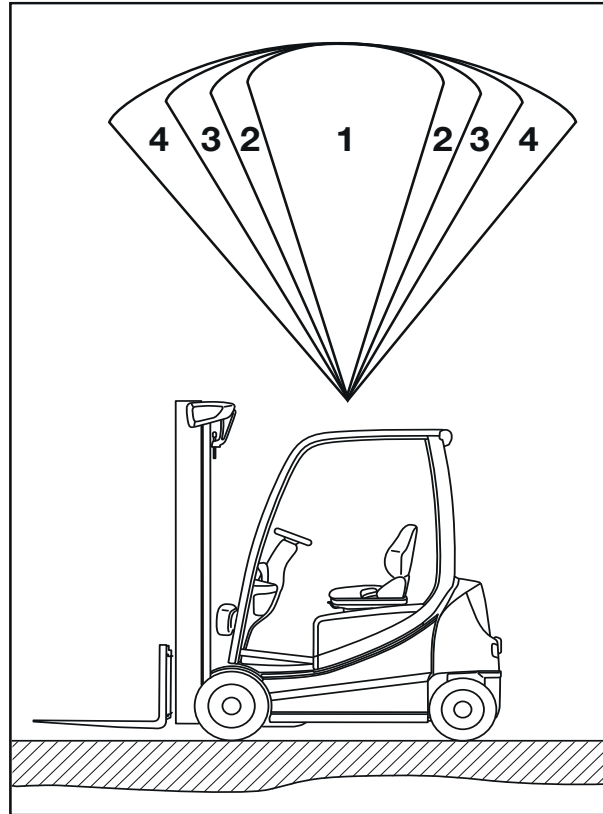

Additional labelling

Adhesive label next to the display-operating unit

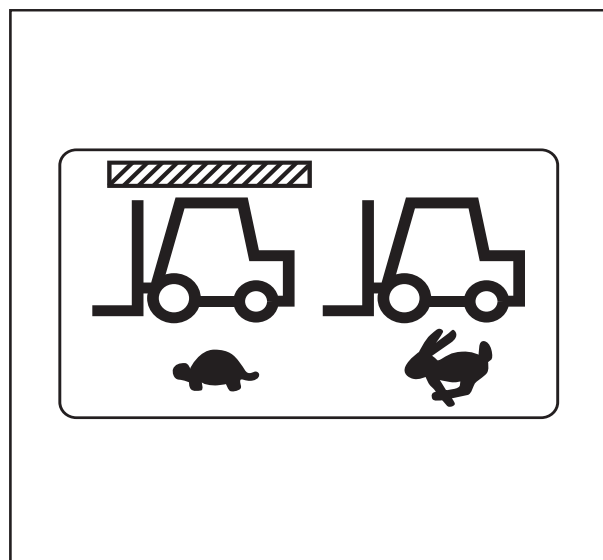

Cab

Opening the cab door

⚠ DANGER

There is a risk of damage through collision if the cab door opens while driving.

- The cab door must be latched securely in the engaged position.

Opening the cab door from the outside:

- Insert the key in the door lock (5), unlock and remove the key.
- Pull the door handle (4) and release the door lock.
- Open the cab door (3) by pulling outwards.

Opening the cab door from the inside:

- Take hold of the handlebar (2) and latch (1).
- Press the latch in and push the cab door outwards.

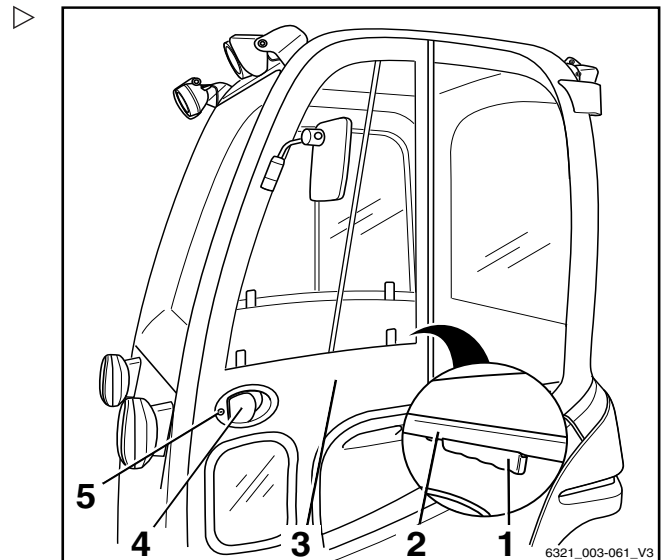

4 Operation

Cab

Closing the cab door

⚠ DANGER

There is a risk of damage caused by collision if the cab door opens while driving.

- The cab door must be latched securely in the engaged position.

Opening the side windows

⚠ WARNING

There is a risk of crushing between the window frame and side window from the side windows slipping inadvertently during travel.

- Make sure that the handle engages securely in the corresponding stop slot.

Opening the rear side window:

- Press the handle (3) together and slide the rear side window (2) forwards.

Opening the front side window:

The front side window (1) can be opened in the same way as the rear side window.

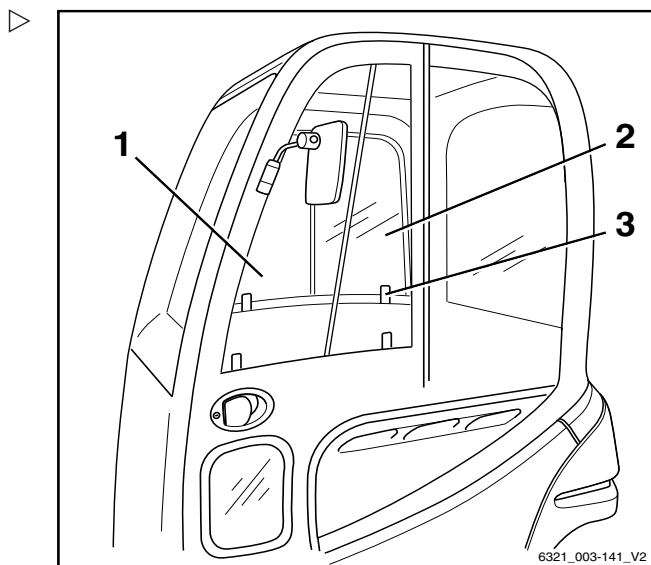

Closing the side windows

⚠ WARNING

There is a risk of crushing between the window frame and side window from the side windows slipping inadvertently during travel.

- Make sure that the handle engages securely in the corresponding stop slot.

Closing the rear side window:

- Press the handle (3) together and pull the rear side window (2) to the rear.

Closing the front side window:

The front side window (1) can be closed in the same way as the rear side window.

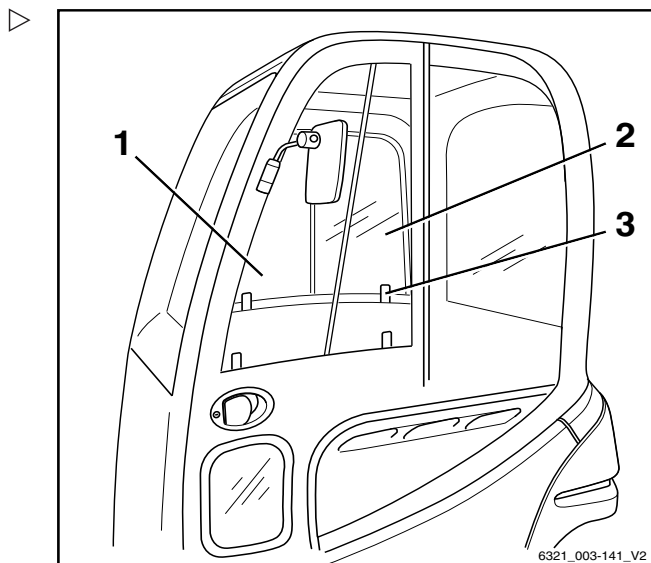

Operating the interior lighting

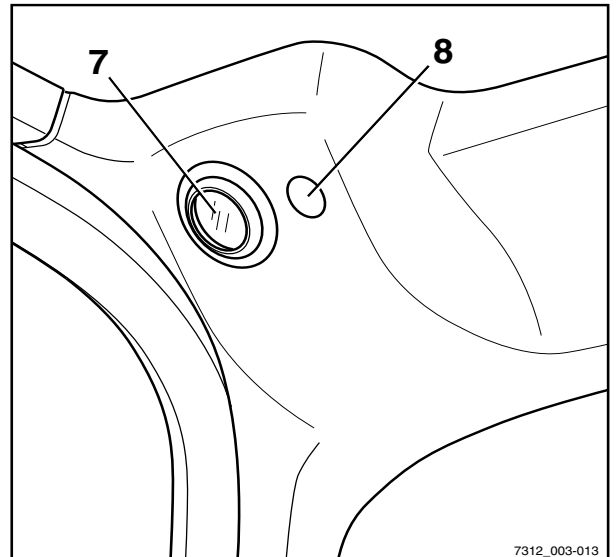

7312_003-013

- Switch the interior lighting (7) on or off using the switch (8) or button (1).

The "interior lighting" symbol (2) appears in the display.

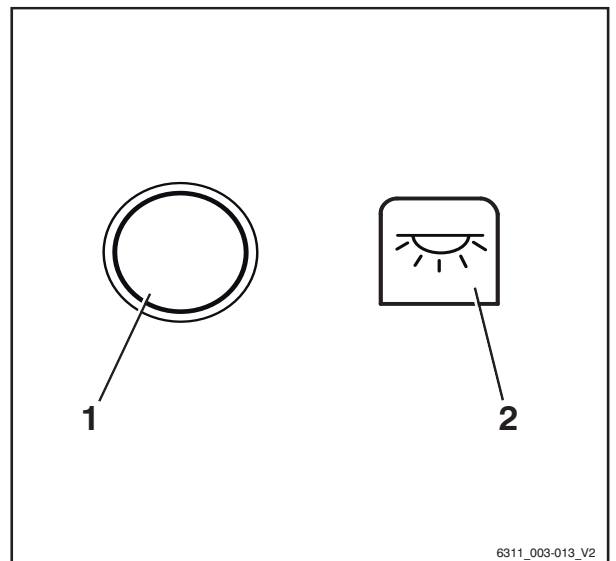



6311_003-013_V2

4 Operation

Cab

Operating the rear window heating

- Press Softkey  (1) to switch on the rear window heating.

Rear window heating is switched on. The  symbol is displayed.

- Press Softkey  (1) to switch off the rear window heating.

Rear window heating is switched off. The  (2) symbol is displayed.

 NOTE

Rear window heating will switch off automatically after approximately 10 minutes.

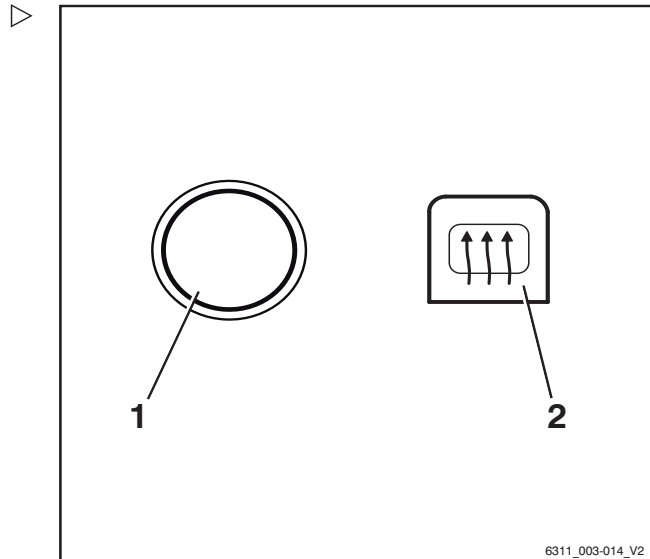

Radio (variant)

The radio (1) and the loudspeakers (2) are an equipment variant. If the truck is equipped with a radio and loudspeakers, they are integrated into the roof lining.

The description and operation can be found in the separate operating instructions for the radio.

 WARNING

The driver's attention is adversely affected by operating the radio or listening to excessive volume while driving or handling loads. There is a risk of accident!

- Do not use the radio when driving or when handling loads.
- Set the radio volume so that you can still hear warning signals.

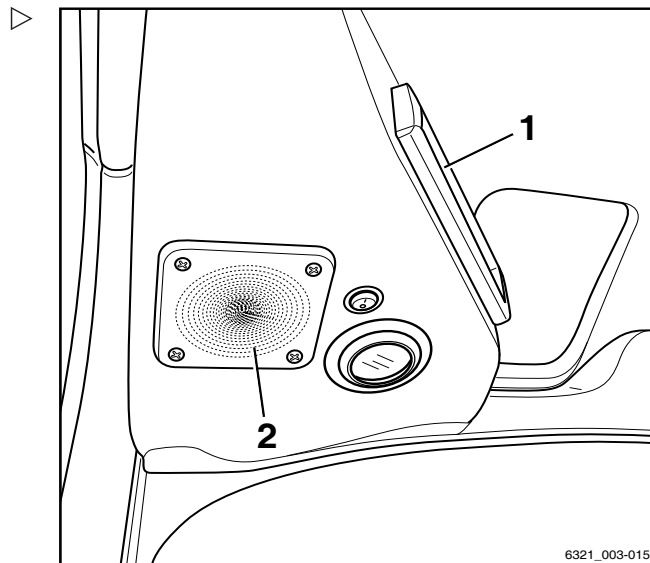

Heating system (variant)

Switching on the blower and heating system



⚠ DANGER

By taking in heavily polluted surrounding air into the closed cab there is a danger of poisoning!

The heater must not be operated in the vicinity of storage areas or the like in which fuel vapours or fine dust (e.g. coal, wood or grain dust) can form.



⚠ DANGER

There is a risk of explosion due to gases being given off or igniting as a result of heat.

- Do not expose spray cans or gas cartridges to the flow of hot air.

- Rotate the blower switch (1) clockwise to the desired blower position.

The blower is in operation and runs at the speed level selected by the blower switch (1).



⚠ DANGER

The heating system overheats if the hot air cannot escape from it. There is a risk of fire!

The heating system may only be switched on if the blower is running and the heating system is not covered by objects (such as a jacket or cover).

- Always switch the blower on first.
- Do not switch the heating system on until the blower is switched on.
- Remove existing objects away from the heating system or air outlets.



⚠ DANGER

The heating system housing can become very hot when the heating system is operating. There is a risk of burns if it is touched!

- Do not touch the heating system housing during operation.
- Only touch the switches provided.

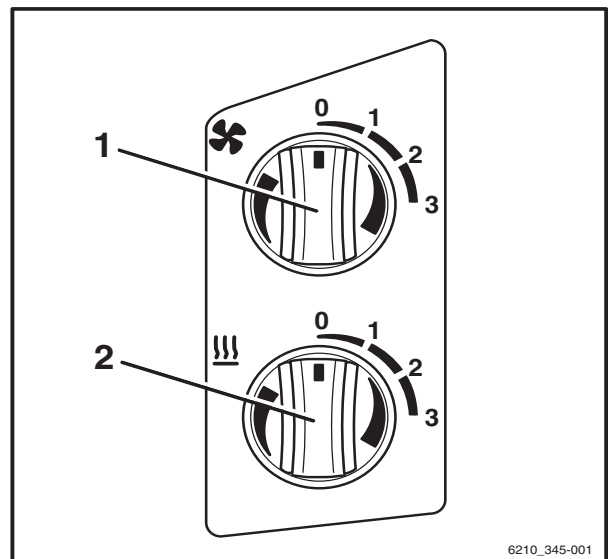

4

Operation

Cab

- Rotate the heating level switch (2) clockwise to the desired heating level.

The heating system is in operation. The air is heated up to the heating level set by the heating level switch (2).

Selecting blower settings

Setting blower to low:

- Set blower switch (1) to level 1.

Setting blower to medium:

- Set blower switch (1) to level 2.

Setting blower to high:

- Set blower switch (1) to level 3.

Setting heating levels

Set heating system to low (50%):

- Set heating level switch (2) to level 1.

Set heating system to medium (75%):

- Set heating level switch (2) to level 2.

Set heating system to high (100%):

- Set heating level switch (2) to level 3.

Turn off the heating system and blower



! DANGER

The heating system overheats if the hot air cannot escape from it. There is a risk of fire!

The blower may only be turned off if the heating system is turned off.

- Always turn the heating system off first.
- Only turn the blower off when the heating system is switched off.

- Rotate the heating level switch (2) anticlockwise to heating level 0.

The heating system is out of order.

- Rotate the blower switch (1) anticlockwise to blower position 0.

The blower is out of order.

Change fuses



⚠ DANGER

Using the wrong fuses can result in short circuits. There is a risk of fire!

- Only use fuses with the prescribed nominal current; see ⇒ Chapter "Replacing fuses", P. 5-402.

Push-up roof window (variant)

⚠ WARNING

Risk of crushing!

- When closing the roof window, do not reach between the roof window and the overhead guard.
- Do not reach in to touch components as they are being closed.

The push-up roof window (1) is an equipment variant.

- To unlock and open the roof window, rotate the handle (2) in an anti-clockwise direction and use it to push the roof window upwards.

The roof window is held in the open position by means of gas springs (3).

- To close and lock the roof window, pull the roof window downwards using the handle and rotate the handle in a clockwise direction

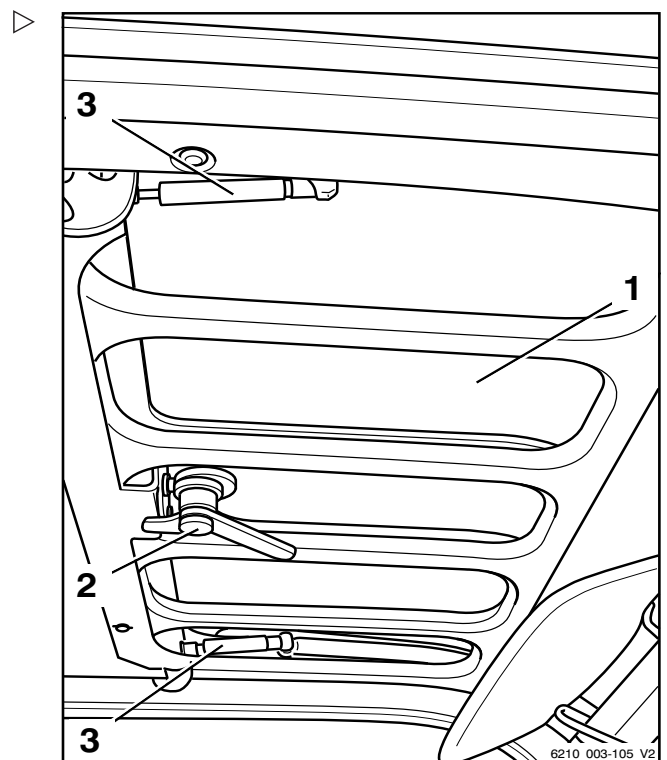

4

Operation

Cab

Clipboard (variant)

The clipboard (1) with reading lamp (2) is an equipment variant.

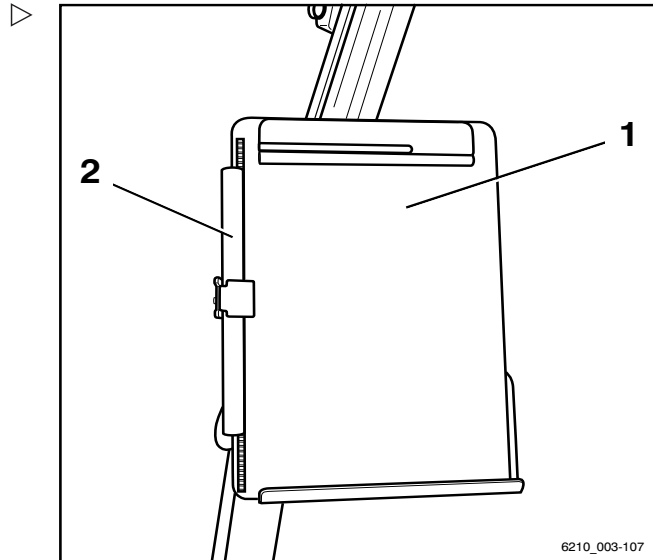

Trailer operation

Towed load

⚠ DANGER

There is an increased risk of accident when using a trailer.

Using a trailer changes the truck handling characteristics. When towing, operate the truck such that the trailer train can be safely driven and braked at all times. The maximum permissible speed when towing is 5 km/h.

- Do not exceed the permissible speed of 5 km/h.
- Do not couple the truck in front of rail vehicles.
- The truck must not be used to push any kind of trolley.
- It must be possible to drive and brake at all times.

⚠ CAUTION

Risk of damage to components!

The maximum towed load for occasional towing is the rated capacity specified on the nameplate. Overloading can lead to component damage on the truck. The sum of the actual towed load and the actual load on the fork must not exceed the rated capacity. If the existing towed load corresponds to the rated capacity of the truck, no load may be transported on the fork at the same time. The load can be distributed between the fork and the trailer.

- Check the load distribution and adjust it to correspond to the rated capacity.
- Observe the permissible rigidity value of the tow coupling.

⚠ CAUTION

Risk of damage to components!

The maximum towed load only applies when towing unbraked trailers on a level surface (maximum deviation +/- 1%) and on firm ground. The towed load must be reduced if towing on gradients. If necessary, notify the authorised service centre of the application conditions. The service centre will provide the required data.

- Inform the authorised service centre.

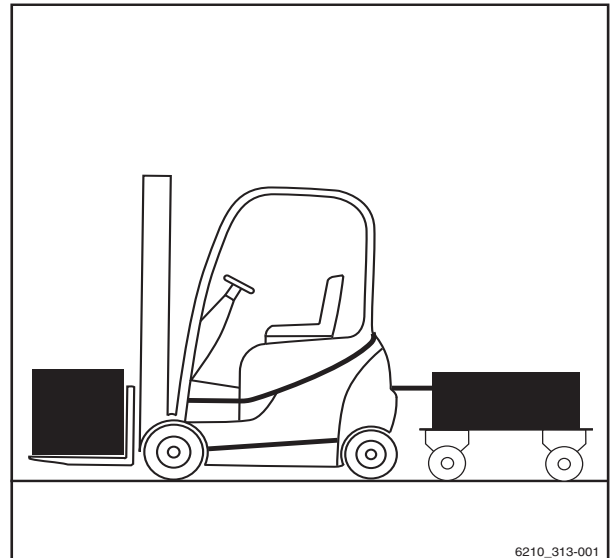

6210_313-001

4

Operation

Trailer operation

⚠ CAUTION

Risk of damage to components!

A support load is not permitted.

- Do not use trailers with tillers supported by the tow coupling.

This truck is suitable for the occasional towing of trailers. If the truck is equipped with a towing device, this occasional towing must not exceed 2% of the daily operating time. If the truck is to be used for towing on a more regular basis, the manufacturer should be consulted.

Coupling pin in the counterweight

Coupling the trailer

⚠ DANGER

If you briefly leave the truck to couple or uncouple the trailer, there is a risk to life caused by the truck rolling away and running you over.

- Apply the parking brake.
 - Lower the forks to the ground.
 - Switch off the key switch and remove the key.
-
- Take measures to prevent the trailer from rolling away, e.g. use wheel chocks (1).

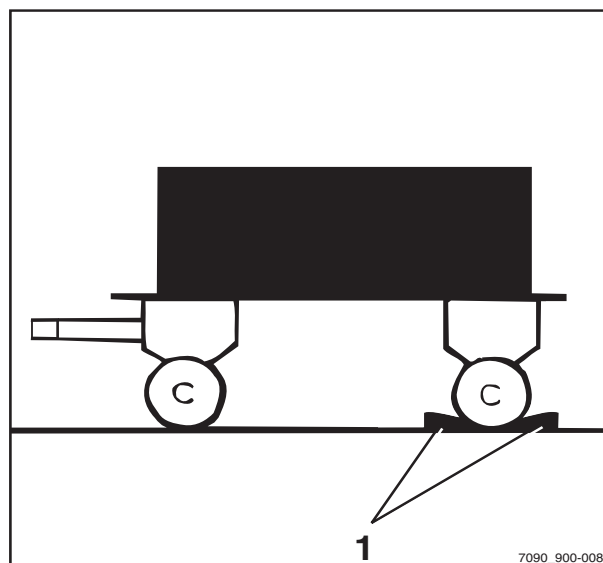

7090_900-008

Operation

4

Trailer operation

- Push the coupling pin (2) down, turn 90° and pull out.
- Adjust tiller height.

⚠ DANGER

People can become trapped between the truck and trailer.

When hooking up, ensure that no one is between the truck and trailer.

- Slowly move the truck back.
- By moving the truck back, introduce the tiller into the recess (3) in the counterweight.

⚠ DANGER

If the coupling pin or securing bush are lost or destroyed during towing, the trailer will work loose and become uncontrollable. This causes a risk of accident!

- Use only original coupling pins that have been checked carefully.
- Ensure that the coupling pin is correctly inserted and secured.
- Insert the coupling pin into the counterweight, press downwards against the spring pressure and turn 90° (the coupling pin is locked in this position).
- Remove any items used to prevent the trailer from rolling away.

Uncoupling the trailer

- Take measures to prevent the trailer from rolling away, e.g. use wheel chocks.

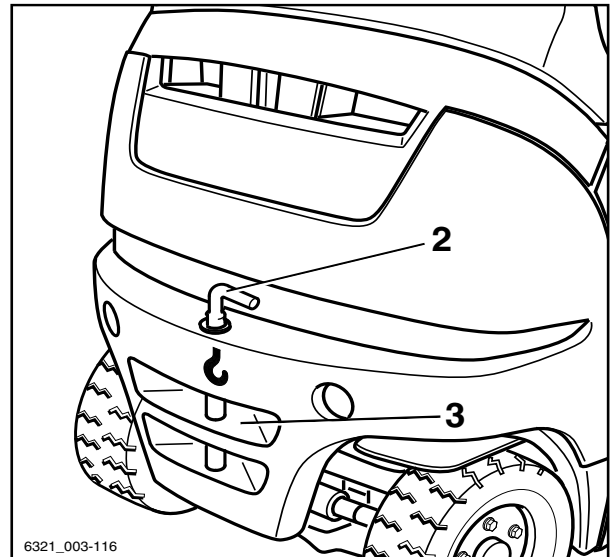

4 Operation

Trailer operation

- Push the coupling pin (2) down, turn 90° and pull out.
- Slowly move the truck forwards and guide the tow-bar eye completely out of the counterweight.
- Insert the coupling pin into the counterweight, press downwards against the spring pressure and turn 90° (the coupling pin is locked in this position).

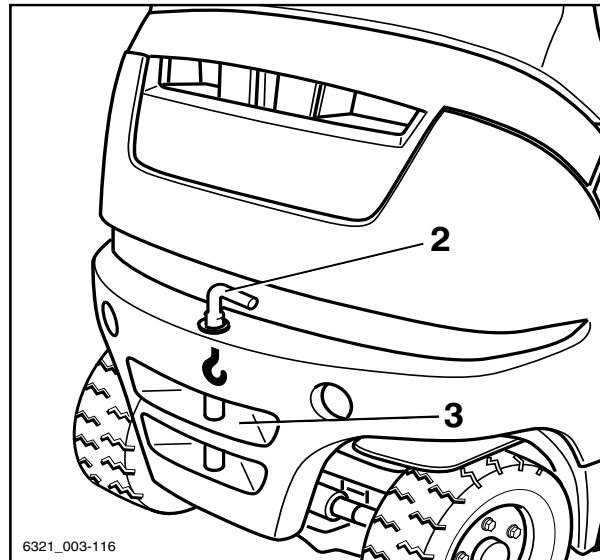

6321_003-116

Automatic tow coupling

⚠ DANGER

People may be trapped between the truck and trailer.

When hooking up, ensure that no one is between the truck and trailer.

⚠ DANGER

Never jack up the truck on the tow coupling or use it for crane lifting. The tow coupling is not designed for this and could be deformed or damaged. This could cause the truck to fall, with potentially fatal consequences!

- Use the tow coupling only for towing.
- For jacking up and crane loading, use only the designated lifting points.

⚠ DANGER

The tow coupling is not designed to support loads and could become deformed or destroyed. This could cause the supported load to fall, with potentially fatal consequences!

- The tow coupling should be subjected only to horizontal loads, i.e. the tiller must be horizontal.



⚠ DANGER

If you briefly leave the truck to couple or uncouple the trailer, there is a risk to life caused by the truck rolling away and running you over.

- Apply the parking brake.
- Lower the forks to the ground.
- Switch off the key switch and remove the key.

⚠ WARNING

Never reach between the coupling pins and the towing jaws. If the component moves suddenly there is a risk of injury!

- To release the coupling pin, actuate the corresponding lever or use a suitable device (e.g. assembly lever).
- When not in use, close the automatic tow coupling.

⚠ WARNING

Risk of damage due to component collision.

A truck with tow coupling needs more room for manoeuvring due to its overhang. The tow coupling can damage the racking or the tow coupling itself when manoeuvring. If there is a collision with the tow coupling, test the tow coupling for damage such as cracks. A damaged tow coupling must not be used again.

- Always manoeuvre carefully and with sufficient room.
- In the case of a collision, test the tow coupling for damage.
- Replace tow coupling if damaged, if necessary contact the authorised service centre.

⚠ WARNING

Risk of damage to the tow bar eye or tiller!

Due to the truck's rear wheel steering, the side slewing angle of the tiller may not be adequate. The coupling or the tiller may be damaged! The tow bar eye of the tiller must fit the tow coupling in terms of shape and size.

- Ensure that the tow bar eye and tiller fit correctly.
- Avoid sharp cornering.
- Exercise care when travelling and manoeuvring in reverse.

4

Operation

Trailer operation

⚠ WARNING

Risk of component damage if the tiller in the tow coupling is tilted!

The tiller should be kept as horizontal as possible when towing. This ensures that the rotation range is sufficient at the top and bottom. The authorised service centre can adjust the assembly height for the tow coupling to the tiller height if necessary.

- Make sure that the tiller is level.
- To change the coupling height, contact the authorised service centre.

Coupling model RO*243

i NOTE

Tow coupling RO 243 is intended for a tow-bar eye in accordance with DIN 74054 (bore diameter: 40 mm).

- Take measures to prevent the trailer from rolling away, e.g. use wheel chocks (1).
- Adjust the tow bar eye of the tiller so that it is at the centre of the towing jaws.

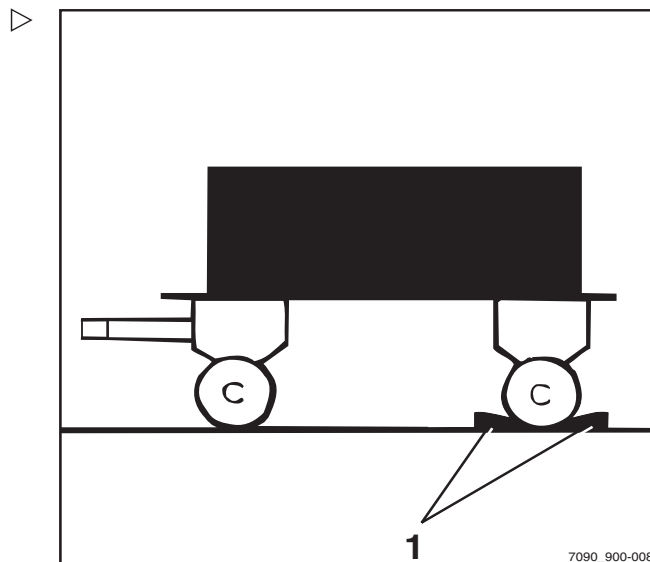

- Pull out the safety handle (3).
- Push the hand lever (2) upwards.

⚠ DANGER

Persons may become trapped between the truck and trailer.

When hooking up, ensure that no one is between the truck and trailer.

⚠ CAUTION

When being coupled, the tow-bar eye must engage in the middle of the coupling jaw. Failure to follow these instructions could result in damage to the coupling jaw or to the tow-bar eye!

- Ensure that the tow-bar eye enters the coupling jaw centrally.

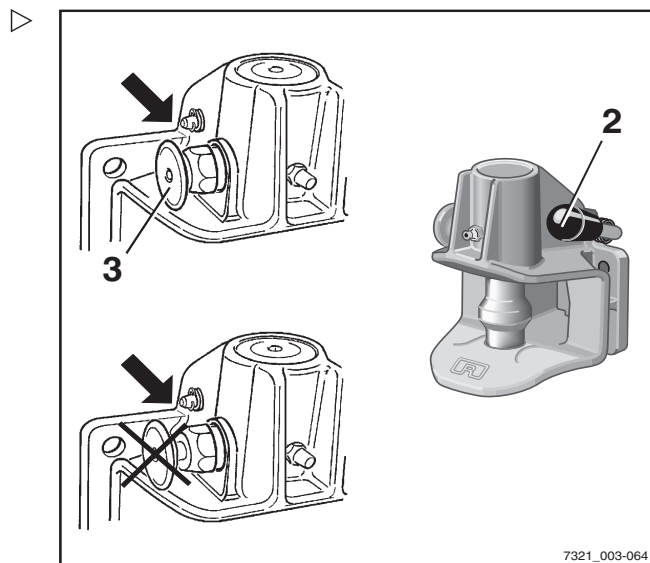

- Slowly move the truck back.

⚠ DANGER

If the coupling pin drops out during towing, the trailer will work loose and can no longer be controlled. There is a risk of accident!

A protruding safety handle means that the tow bar eye has not been coupled correctly. The trailer must not be towed in this condition.

- Ensure that the safety handle is flush with the securing bush.
- If the safety handle protrudes, repeat the coupling process.

-
- Remove any items used to prevent the trailer from rolling away.
 - Tow the trailer.

Closing model RO*243 by hand

⚠ DANGER

Risk of injury from hand becoming trapped!

Do not reach into the coupling pin area. If, for example, a tow rope is to be secured in the tow coupling, use only a suitable device to close the tow coupling (e.g. assembly lever).

-
- Use a suitable device (e.g. assembly lever) to push the coupling pin up.

The coupling pin is released from the latch and the tow coupling then closes automatically.

Uncoupling model RO*243

- Take measures to prevent the trailer from rolling away, e.g. use wheel chocks.
- Pull out the safety handle (3).
- Push the hand lever (2) upwards.
- Slowly drive the truck forwards until the tow-bar eye and towing jaws are disconnected.
- Close the tow coupling by hand.

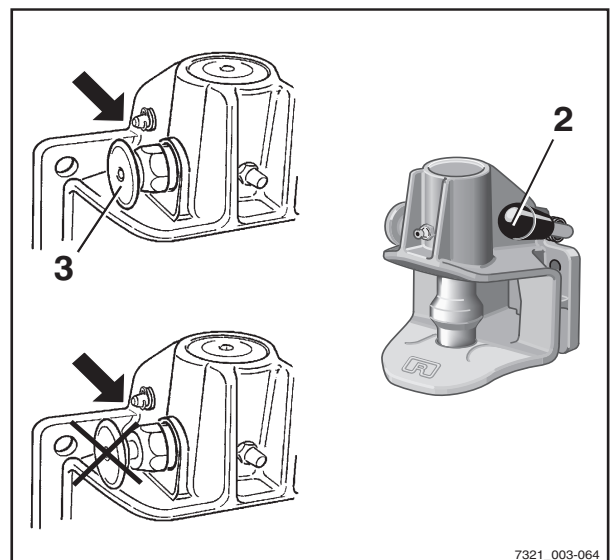

7321_003-064

4

Operation

Trailer operation

Coupling model RO*244 A

i NOTE

Trailer coupling RO 244 is intended for a tow bar eye in accordance with DIN 74054 (bore diameter 40 mm) or DIN 8454 (bore diameter 35 mm).

- Take measures to prevent the trailer from rolling away, e.g. use wheel chocks.
- Adjust the tow bar eye of the tiller so that it is at the centre of the towing jaws.
- Push the hand lever (2) upwards until it snaps into place.

The tow coupling is opened.

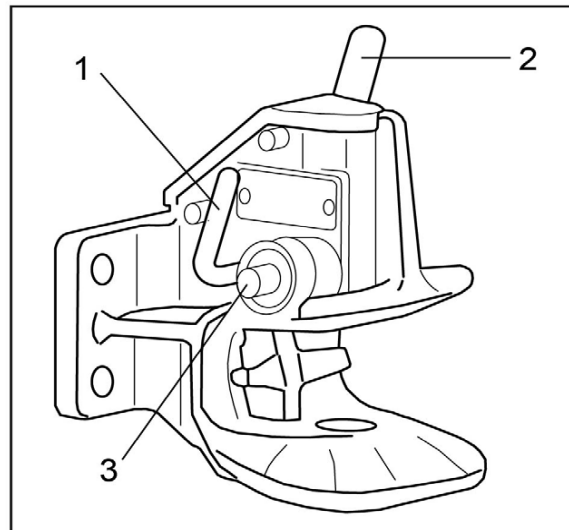

⚠ DANGER

People can become trapped between the truck and trailer!

When hooking up, ensure that no one is between the truck and trailer.

⚠ CAUTION

When being coupled, the tow-bar eye must engage in the middle of the coupling jaw. Failure to follow these instructions could result in damage to the coupling jaw or to the tow-bar eye!

- Ensure that the tow-bar eye enters the coupling jaw centrally.
- Move the truck back slowly until the tow bar eye is inserted centrally into the coupling jaw of the tow coupling and the coupling pin engages.

i NOTE

The coupling pin is correctly engaged if the control pin (3) does not protrude out of its guide.

⚠ DANGER

If the coupling pin drops out during towing, the trailer will work loose and can no longer be controlled. There is a risk of accident!

The control pin (3) must not protrude out of its guide.

- Ensure that the coupling pin is engaged correctly.

If the coupling pin is not correctly engaged:

- Remove any items used to prevent the trailer from rolling away.
- Move the truck with the trailer forwards approx. 1 m and then move it back slightly.
- On the coupling pin, check again that the control pin does not protrude out of its guide.

-
- Remove any items used to prevent the trailer from rolling away.

- Tow the trailer.

Closing model RO*244 A by hand

⚠ DANGER

Risk of injury from hand becoming trapped!

Do not reach into the coupling pin area. If, for example, a tow rope is to be secured in the tow coupling, only actuate the tow coupling via the closing lever (1).

- Press the closing lever (1) downwards as far as it will go.

The tow coupling is closed.

Uncoupling model RO*244 A

- Take measures to prevent the trailer from rolling away, e.g. use wheel chocks.
- Push the hand lever (2) upwards until it snaps into place.

The tow coupling is opened.

- Slowly drive the truck forwards until the tow-bar eye and towing jaws are disconnected.
- Close the tow coupling by actuating the closing lever (1).

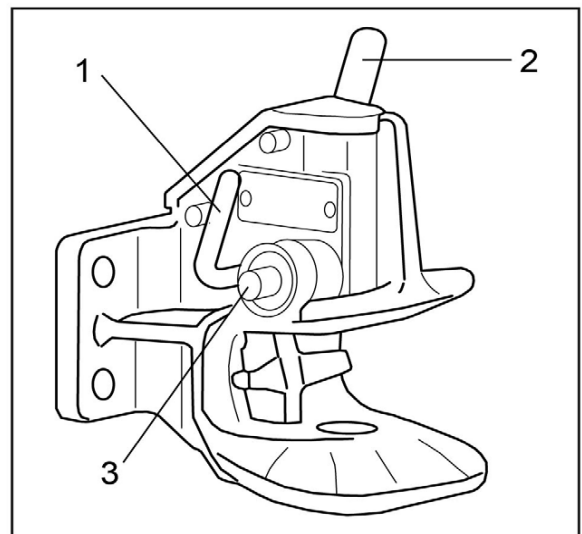

4

Operation

Trailer operation

i NOTE

To protect the lower coupling pin bush against contamination, always keep the tow coupling closed.

Coupling model RO*245

i NOTE

Trailer coupling RO 245 is intended for a tow-bar eye in accordance with DIN 74054 (bore diameter 40 mm) or DIN 8454 (bore diameter 35 mm).

- Take measures to prevent the trailer from rolling away, e.g. use wheel chocks.
- Adjust the tow bar eye of the tiller so that it is at the centre of the towing jaws.
- Push the hand lever (5) upwards.
- The tow coupling is opened.

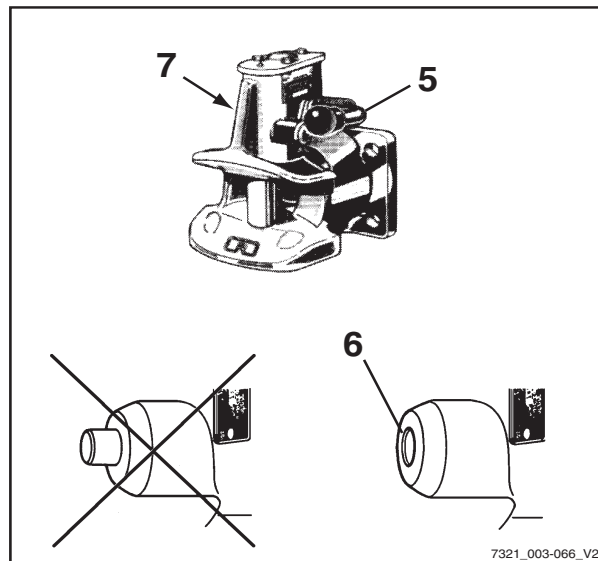

7321_003-066_V2

⚠ DANGER

People can become trapped between the truck and trailer!

When hooking up, ensure that no one is between the truck and trailer.

- Slowly move the truck back.

⚠ DANGER

If the coupling pin drops out during towing, the trailer will work loose and can no longer be controlled. There is a risk of accident!

A protruding safety handle means that the tow bar eye has not been coupled correctly. The trailer must not be towed in this condition.

- Make sure that the control pin does not protrude from the control bush.
 - Repeat the coupling process if necessary.
-
- Remove any items used to prevent the trailer from rolling away.
 - Tow the trailer.

Operation

4

Trailer operation

Uncoupling model RO*245

- Take measures to prevent the trailer from rolling away, e.g. use wheel chocks.
- Push the hand lever (5) upwards.
- Slowly drive the truck forwards until the tow-bar eye and towing jaws are disconnected.
- Push the closing lever (7) on the left side of the tow coupling down as far as it will go.

The tow coupling is closed.

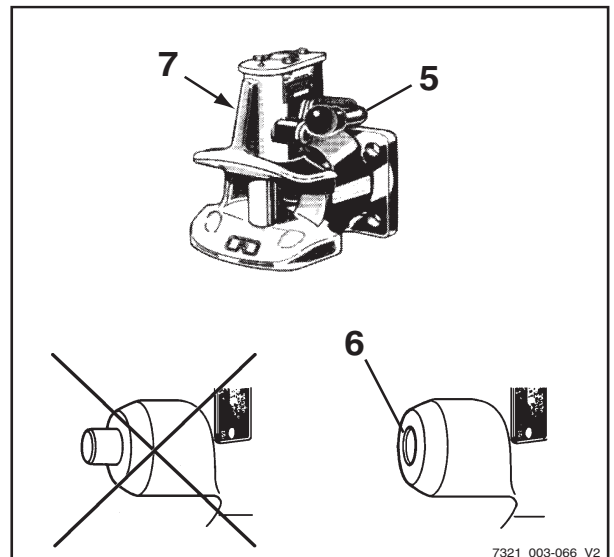

Coupling model RO*841

i NOTE

Tow coupling RO 841 is intended for a tow-bar eye in accordance with DIN 74054 (bore diameter 40 mm).

- Take measures to prevent the trailer from rolling away, e.g. use wheel chocks.
- Push the hand lever (7) upwards until it snaps into place.

⚠ DANGER

People may be trapped between truck and trailer.
When hooking up, ensure that no one is between the truck and trailer.

⚠ CAUTION

When being coupled, the tow-bar eye must engage in the middle of the coupling jaw. Failure to follow these instructions could result in damage to the coupling jaw or to the tow-bar eye!

- Ensure that the tow-bar eye enters the coupling jaw centrally.

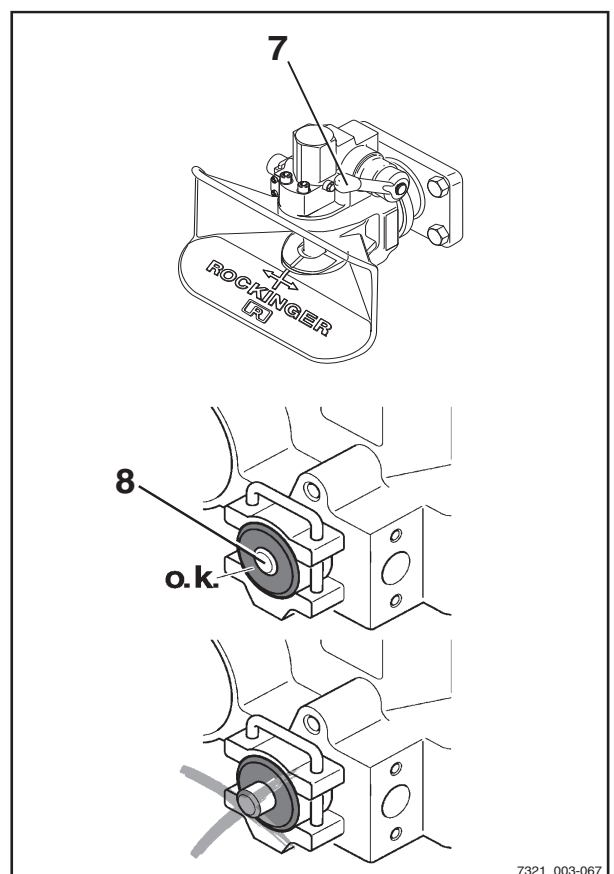

Trailer operation

⚠ DANGER

If the coupling pin drops out during towing, the trailer will work loose and can no longer be controlled. There is a risk of accident!

A protruding safety handle means that the tow bar eye has not been coupled correctly. The trailer must not be towed in this condition.

- Make sure that the control pin does not protrude from the control bush.
 - Repeat the coupling process if necessary.
-
- Remove any items used to prevent the trailer from rolling away.
 - Tow the trailer.

Uncoupling model RO*841

- Take measures to prevent the trailer from rolling away, e.g. use wheel chocks.
- Push the hand lever (7) upwards.
- Slowly drive the truck forwards until the tow-bar eye and towing jaws are disconnected.
- Close the tow coupling.

Towing trailers

- Drivers who are towing a trailer for the first time must practise driving with a trailer in a suitable area.
- When passing through narrow road areas (entrances, gates etc.), observe the dimensions of the trailer and load.
- When towing multiple trailers, ensure a sufficient minimum distance to fixed installations when turning and cornering.

The permissible length of the trailer trains depends on the roadways to be driven and may need to be determined during the test drive.

It is the responsibility of the operating company to instruct the drivers regarding the permissible number of trailers and, where required, any additional speed reductions on individual sections of the route.

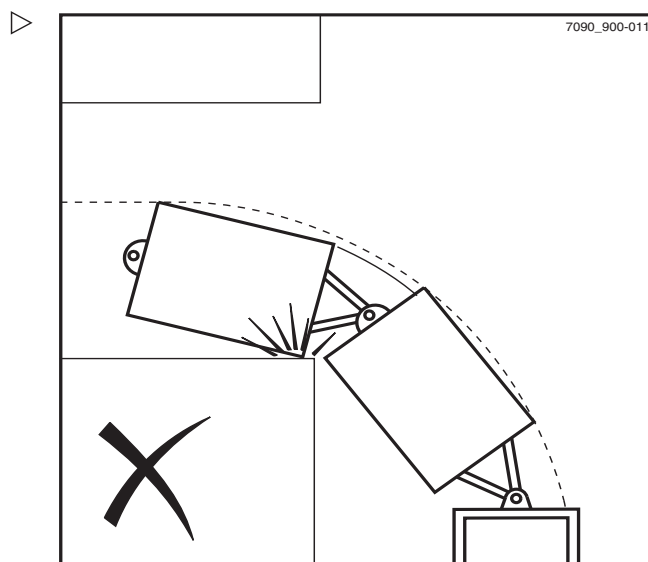



 NOTE

Please observe the definition of the following responsible persons: "operating company" and "driver".

Cold store application

Cold store application

The truck features cold store equipment (variant), making it suitable for use in cold stores.

It is equipped for two different types of application and marked with the cold store symbol.

The display-operating unit is heated in this variant.

As another variant, the truck can be equipped with a driver's cab with a heating system.

Types of application

There are two different types of cold store application for the truck, distinguished by two different temperature ranges.

- 1 Constant deployment in temperature range -5°C , brief deployment down to -10°C .
- 2 Alternating between indoor use down to -32°C and outdoor use to $+25^{\circ}\text{C}$, briefly up to $+40^{\circ}\text{C}$.

Operation

⚠ CAUTION

Changing from a cold internal temperature to a warm outside temperature may result in the formation of condensation water. This water may freeze on re-entry to the cold store, blocking moving parts of the truck.

It is essential that close attention is paid to the duration of deployment in the different temperature ranges for both types of application.

Before being used in the cold store, the truck must be dry and warmed up.

The truck must not leave the cold store area for more than 10 minutes. By adhering to this rule, condensation water will not have time to form.

If the truck stays outside for more than 10 minutes, it must remain there at least until the condensation water has drained away and the truck has dried off. Depending on the weather, this will take at least 30 minutes.

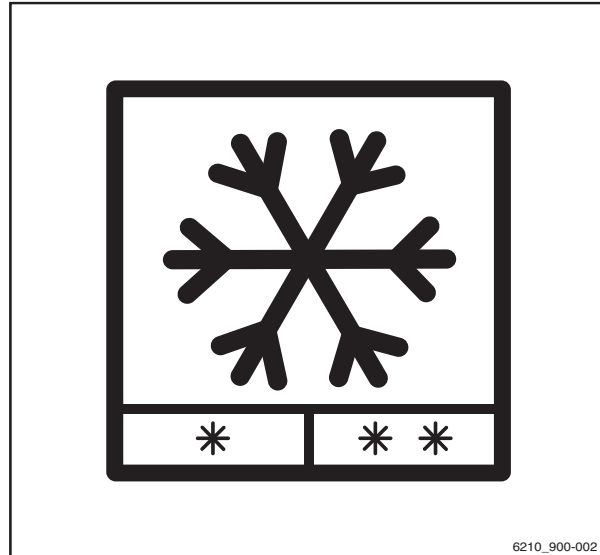

⚠ WARNING

Risk of injury!

If condensation water freezes in the cold store, do not try to free parts that have become stuck with your hands.

- To ensure operational safety, drive the truck for approximately 5 minutes and actuate the brake several times.
- Actuate all hydraulic lifting functions several times.

This warm-up phase is necessary to ensure that the oil reaches the operating temperature.

- Always park the truck outside the cold store.

⚠ CAUTION

Risk of component damage!

The lead-acid batteries must not be left in the cold store overnight without power uptake or charging.

- Charge the battery outside the cold store. Operate the truck using a replacement battery.

Using batteries in the cold store

To compensate for the reduction in capacity at low temperatures, it is advisable to use lead-acid batteries with the maximum nominal capacity in the respective battery dimensions for the truck series.

Electric trucks must not be parked in a cold area for any longer than necessary. This also applies to unused batteries. The charging station and the parking area for trucks and batteries must be at normal room temperature (not below 10°C). Charging is extremely slow at low temperatures. At temperatures below 10°C, the battery cannot be fully charged with the usual charging parameters.

- Charge the battery fully before each shift.
- During the gassing phase, always top up with distilled water.

To prevent the distilled water from freezing, it must be mixed with the battery acid.



Cold store application

Water top-up systems must not be used at temperatures below 0°C, as this could cause the systems and the water present in the hose lines to freeze.

The battery voltage when discharged is thus generally lower at low temperatures. The final discharged voltage is reached earlier, meaning the capacity of the battery is lower.

Display messages

Display content

On the display of the display-operating unit, event-related messages may appear due to certain truck conditions.

The following types of message may appear individually or in combination:

- A graphic symbol (2)
- The message (3)
- An error code (4) consisting of a letter and a four-digit number



NOTE

Each time a message appears, the "Malfunction" display (1) also lights up.

Messages are always shown repeatedly and for a certain period of time, according to the event.

In the case of successive events, the respective messages are displayed one after another on the display.

After a few seconds, the display will alternate between the last shown operating display and the message.

The frequency of alternation depends on the type of event.

- If a message appears, follow these operating instructions.

Once the event is remedied, the message will disappear.

If a malfunction continues to occur, the message will continue to appear.

- Park the truck safely.
- Inform the authorised service centre.

Error code table

The table gives an overview of possible displays. The "Comment" column contains information on how to proceed if any of these messages are displayed.

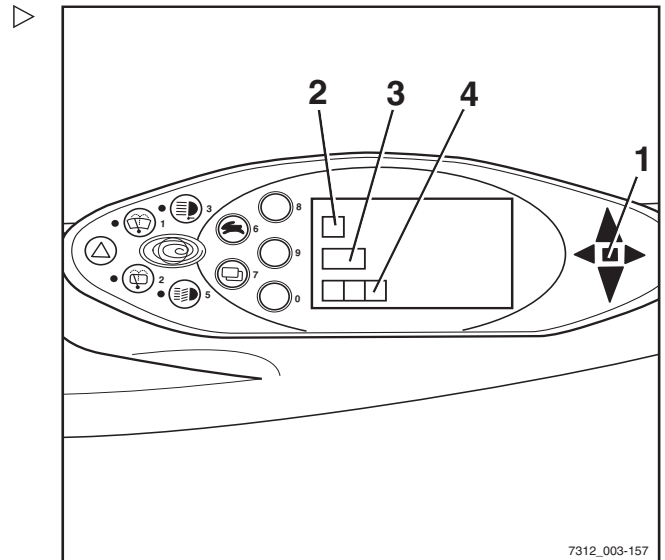



4

Operation

Display messages

Message text (English)/ Error code	Comment
OVERHEATING A5022	The traction motor(s) is/are too hot. 1. phase: regulation of acceleration and speed. 2. phase: limitation of the phase current in the converter (emergency driving function is retained). The error code automatically disappears as soon as the temperature is below the limit. If the error occurs frequently, notify the authorised service centre.
OVERHEATING A5364	Pump converter is too hot. Notify the authorised service centre.
ACCELERATOR A3002 A3003 A3004 A3005 A3006 A3007 A3505	Sensor fault; the truck cannot be driven. Notify the authorised service centre.
ACCELERATOR A3008	Accelerator voltages (for dual pedal) do not match; truck cannot be driven. Notify the authorised service centre.
ACCELERATOR A3811	Accelerator configuration is invalid. The truck cannot be driven. Notify the authorised service centre.
BRAKE SENSOR A3016 A3017	Sensor fault; truck can only be driven at emergency mode speed. Notify the authorised service centre.
CONFIGURATION A2111 A3801 A3812	Parameterisation error; drive unit and hydraulic drive not functioning. Notify the authorised service centre.
SEAT SWITCH A302	The seat switch has not been operated for approx. eight hours. Truck can possibly still be driven at a reduced speed and with reduced lifting capacity. Stand up briefly and then sit down again. If this does not resolve the problem, notify the authorised service centre.
STEERING A3215 A3216 A3570	Sensor fault; truck can be driven at emergency mode speed. Notify the authorised service centre.
DIRECTION SWITCH A3020	Switch error; no or limited drive unit function. Notify the authorised service centre.



Message text (English)/ Error code	Comment
LIFTING A3102 A3103	Sensor fault; no or limited hydraulic drive function. Notify the authorised service centre.
TILTING A3107 A3108	Sensor fault; no or limited hydraulic drive function. Notify the authorised service centre.
VERTICAL MAST A3130 A3131 A3132	No hydraulic function. Turn off "vertical lift mast position". Notify the authorised service centre.
VERTICAL MAST ERROR A3135	No hydraulic function. Turn off "vertical lift mast position". Notify the authorised service centre.
EXT1 A3112 A3113	Sensor fault; no or limited hydraulic drive function. Notify the authorised service centre.
EXT2 A3117 A3118	Sensor fault; no or limited hydraulic drive function. Notify the authorised service centre.
POWER SUPPLY A2242	Transmitter power supply short circuit. The truck cannot be driven. Notify the authorised service centre.
SURVEILLANCE A2801 A2802 A2808 A2809 A2810 A2815	Drive unit not functioning. Release accelerator pedal. If this error occurs sporadically, it can be tolerated. If the operational capacity is impaired, notify the authorised service centre.
SURVEILLANCE A2803 A2806	Drive direction is set to neutral. Reselect the drive direction. If this error occurs sporadically, it can be tolerated. If the operational capacity is impaired, notify the authorised service centre.
SURVEILLANCE A2817	Truck is not ready for operation. Turn key switch to the zero position and restart. If this error occurs sporadically, it can be tolerated. If the operational capacity is impaired, notify the authorised service centre.



4 Operation

Display messages

Message text (English)/ Error code	Comment
SURVEILLANCE A2804 A2805 A2807 A2811 A2812 A2813 A2814 A2816 A2818	No or limited drive unit function. Notify the authorised service centre.
SURVEILLANCE A2295	No or limited function of drive unit and hydraulic drive. Notify the authorised service centre.
DRIVE A5031 A5041 A5046 A5301 A5331 A5361	Temperature sensor fault. Notify the authorised service centre.
BATTERY CHANGER A5910	The support roller for the hydraulic battery carrier is not extended. Notify the authorised service centre.
BATTERY CHANGER A5920	Hydraulic pump of the hydraulic battery carrier is overheating. Allow the truck to cool down for one hour.
BATTERY CHANGER A5930	Button error Notify the authorised service centre.
BATTERY CHANGER A5931	Plausibility error from the potentiometer for the hydraulic battery carrier. Notify the authorised service centre.
CONTROL UNIT A3305	CIO not functioning. Notify the authorised service centre.
PARKING BRAKE OIL PRES - SURE A3043	The oil pressure in the parking brake is too low; the drive unit is locked. Notify the authorised service centre.
PARKING BRAKE OIL PRES - SURE A3049	The oil pressure in the parking brake is low; the truck only moves at emergency mode speed. Notify the authorised service centre.
LEVER A4601	The "lifting" operating device has been moved and held in place for too long. The relevant hydraulic function is switched off. As soon as the operating device is released, the message will disappear and the hydraulic function will be available again. If required, the authorised service centre can disable monitoring of the hydraulic functions.



Message text (English)/ Error code	Comment
LEVER A4602	The "tilting" operating device has been moved and held in place for too long. The relevant hydraulic function is switched off. As soon as the operating device is released, the message will disappear and the hydraulic function will be available again. If required, the authorised service centre can disable monitoring of the hydraulic functions.
LEVER A4603	The "auxiliary hydraulics 1" operating device has been moved and held in place for too long. The relevant hydraulic function is switched off. As soon as the operating device is released, the message will disappear and the hydraulic function will be available again. If required, the authorised service centre can disable monitoring of the hydraulic functions.
LEVER A4604	The "auxiliary hydraulics 2" operating device has been moved and held in place for too long. The relevant hydraulic function is switched off. As soon as the operating device is released, the message will disappear and the hydraulic function will be available again. If required, the authorised service centre can disable monitoring of the hydraulic functions.
A4680	Implausible pressure request to the hydraulic pump. Switch the truck off and then on again using the key switch. If the error message persists, notify the authorised service centre.
SERVICE REQUIRED S5950	The lithium-ion battery requires servicing. Notify the authorised service centre.
LITHIUM BATTERY S5951	No CAN communication with the lithium-ion battery. Switch off the truck. Check the battery male connector and reinsert. Switch the truck on again. If the error occurs frequently, notify the authorised service centre.
LITHIUM BATTERY S5961	Overtemperature in the lithium-ion battery. Allow the truck to cool down. The error automatically disappears as soon as the temperature is below the limit. If the error occurs frequently, notify the authorised service centre.
LITHIUM BATTERY S5962	The temperature of the lithium-ion battery is too low. Allow the truck to acclimatise. The error automatically disappears as soon as the temperature is above the limit. If the error occurs frequently, notify the authorised service centre.

4 Operation

Display messages

Message text (English)/ Error code	Comment
LITHIUM BATTERY S5970	Shock event in the lithium-ion battery. Notify the authorised service centre.
LITHIUM BATTERY S6620	Internal error in the lithium-ion battery. Notify the authorised service centre.

General messages

NOTE

Some of the following messages are equipment-specific and may not appear on the display and operating unit of every truck. The following messages are therefore intended only as a reference.

SERVICE BRAKE message

If the message SERVICE BRAKE appears on the display, notify the authorised service centre.

- Park the truck securely for checking by the authorised service centre.
- If multi-disc brakes in the drive wheel units are blocked, tow the truck.

APPLY HANDBRAKE message

DANGER

Risk of fatal injury from being run over if the truck rolls away!

Parking the truck without the parking brake applied is dangerous and is not permitted.

- The truck must not be parked on a slope.
- Only leave the truck when the parking brake has been applied.
- In emergencies, secure the truck using wedges on the side facing downhill.

NOTE

The truck is equipped with a negative spring-operated brake. Switching off the truck will block the multi-disc brakes in the drive wheel units after a few minutes. However, the truck can still roll until the drive wheel units are



blocked. For this reason, the parking brake must always be applied before you leave the truck!

If you park the truck without applying the parking brake and then vacate the driver's seat, the APPLY HANDBRAKE message will appear in the display (variant). An optional signal tone sounds.

- Apply the parking brake.

The APPLY HANDBRAKE message disappears.

If the truck moves even though the parking brake is applied:

- Drive the truck onto level ground and park it safely. Secure it with wedges if necessary.
- Notify the authorised service centre.

BRAKE SENSOR message

If the BRAKE SENSOR message appears in the display, the maximum driving speed will be reduced. The brake sensor in the brake pedal must be checked.

- Notify the authorised service centre.

CODE DENIED message

If the message CODE DENIED appears on the display, the driver PIN has been entered incorrectly three times. The input is then locked for five minutes before another attempt can be made.

- Enter the driver PIN again after five minutes.

ACCELERATOR message

If the ACCELERATOR message appears on the display, the truck will remain stationary. The accelerator must be checked.

- Notify the authorised service centre.

SWITCH OFF TRUCK? message

If the message SWITCH OFF THE TRUCK? appears on the display, the switching-off of the truck is verified.



Display messages

- Press the corresponding softkey on the display and operating unit to switch off the truck or cancel the operation.

PARKING BRAKE ACTIVE message

If the electric parking brake is applied, the **PARKING BRAKE ACTIVE** message appears on the display for 5 seconds.

- Release the parking brake to enable driving mode.

RELEASE PARKING BRAKE message

If the message **RELEASE PARKING BRAKE** appears on the display, driving mode cannot be enabled until the parking brake has been released by pressing the button.

- Release the parking brake by pressing the button.

PARKING BRAKE: APPLY HANDBRAKE! message

If the message **PARKING BRAKE : APPLY HANDBRAKE !** appears on the display, the electric parking brake is faulty.

- Release the parking brake by pressing the button.

LOWER FORKS message

⚠ DANGER

There is a risk of fatal injury from a falling load or parts of the truck being lowered!

Parking the truck with the load lifted is dangerous and is not permitted under any circumstances! The increased safety provided by this function must not be misused in order to take safety risks.

- Lower the load fully before leaving the truck.

The fork is not lowered.

If the fork is above the height sensor, the key switch is turned off and the seat vacated, the LOWER FORKS message appears in the display (variant). An optional signal tone sounds.

- Lower the fork to the ground.

The message LOWER FORKS disappears.

STEERING message

If the STEERING message appears in the display, the truck will only move at emergency mode speed. The steering angle sensor must be checked.

- Notify the authorised service centre.

TILTING SPEED message

If the message TILTING SPEED appears on the display after the welcome screen, the tilting speed of the lift mast on this truck is significantly higher than on previous trucks in this family.

EMERGENCY SWITCH message

WARNING

No electric braking assistance is available when the emergency off switch is actuated!

Actuating the emergency off switch will disconnect the drives from the power supply.

- To brake, actuate the service brake.

The truck is equipped with an emergency off switch. When this switch is actuated, the driving functions and the functions of the working hydraulics are blocked.

The EMERGENCY SWITCH message appears periodically when the following criteria are met:

- The key switch is set to stage "I"
- The emergency off switch is actuated
- An operating device is actuated

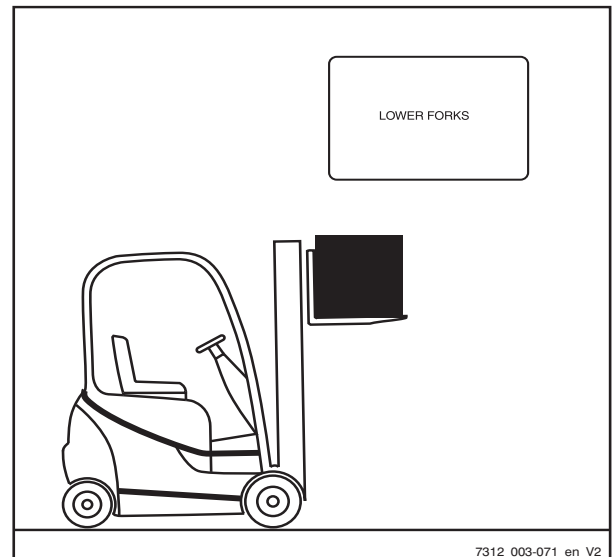

4

Operation

Display messages

? VERTICAL POSITION

If the message ? VERTICAL POSITION appears on the display, calibration of the "vertical lift mast position" has been activated.

- Save the mast position or cancel the calibration.

REFERENCE CYCLE message

If the fork was lowered after the truck was switched off, the control electronics do not know the position of the fork when the truck is restarted. The truck will only travel at a reduced driving speed. Depending on the position of the fork, the message REFERENCE CYCLE (variant) may appear in the display. To align the position with the control electronics, the fork must be raised.

- Switch on the key switch.

The truck will only travel at a reduced driving speed. The message REFERENCE CYCLE may appear in the display.

- Raise the fork.

The message REFERENCE CYCLE goes out, or now appears in the display for the first time and then goes out.

- To drive again, lower the fork to a maximum of 300 mm above the ground.

The truck can now be driven again with no speed limitation.

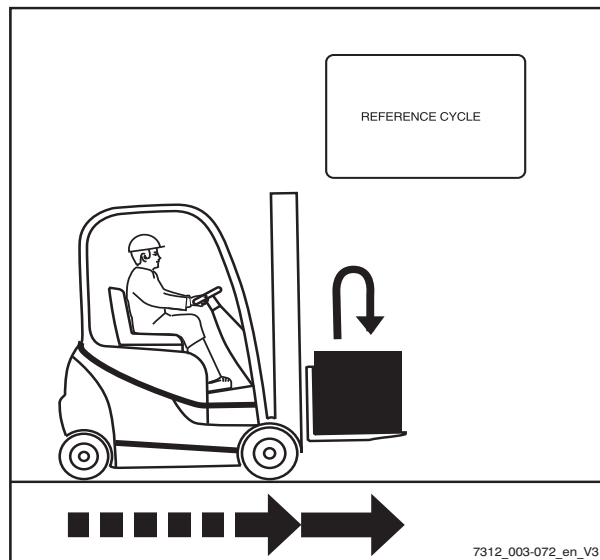

7312_003-072_en_V3

SAFETY BELT message



⚠ DANGER

Risk of fatal injury in the event of falling from the truck if it tips over!

If the truck tips over, the driver is at risk of injury even if a restraint system is used. The risk of injury can be reduced by using a combination of a restraint system and a seat belt. In addition, the seat belt protects against the consequences of rear-end collisions and falling off ramps.

- We recommend that you always use the seat belt.

This device (variant) ensures that if the seat belt is not being used or is being used incorrectly, the truck will only drive slowly or (optionally) will not drive at all.

Depending on the configuration selected, the working hydraulics functions (lifting/tilting) are either available as normal, slowed down or not available at all.

The SAFETY BELT message with the restricted driving and lifting functions is triggered by the following circumstances:

- Seat belt not worn and driver's seat occupied
 - The seat belt is constantly fastened but the driver's seat is only occupied afterwards
 - The seat belt is not fastened until after the key switch has been switched on
 - The seat belt is unfastened while driving
- If the SAFETY BELT message appears, fasten the seat belt in accordance with the regulations.

The truck can again be operated without restrictions.

If the seat belt is released while driving, the truck will be limited to low driving speeds or will be braked to a halt.

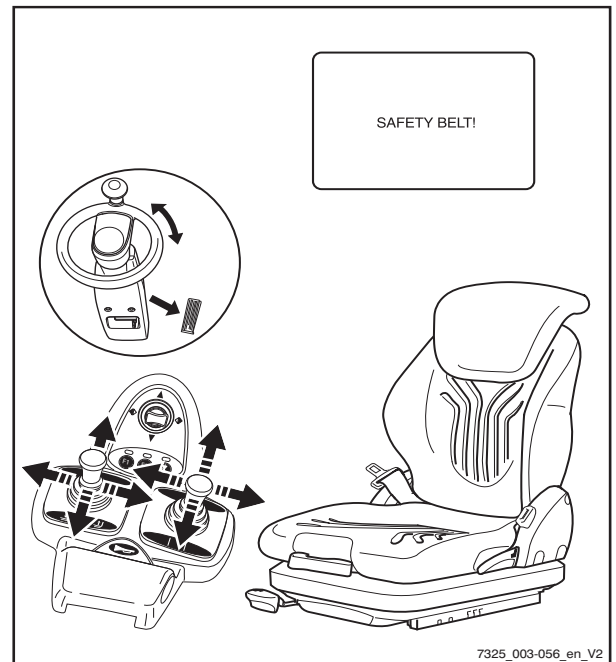

7325_003-056_en_V2



4

Operation

Display messages

⚠ DANGER

Risk of accident!

- The speed must be adjusted to suit the driving situation!

The increased safety provided by this function must not be misused in order to take safety risks.

ARE YOU SURE ? message

If the message ARE YOU SURE ? appears on the display, a prior prompt is verified.

- Press the corresponding softkey on the display and operating unit to continue or to cancel the operation.

SEAT SWITCH message

The truck is equipped with a seat switch.

If the SEAT SWITCH message appears, the driving functions and the working hydraulics are blocked.

The SEAT SWITCH message is triggered by the following situations:

- The seat switch is not actuated while the accelerator pedal or steering wheel is actuated
- The seat switch is not actuated while the operating device for the working hydraulics is actuated
- The shift time has been exceeded
- The operating time has been exceeded

i NOTE

The operating devices shown in the following illustrations are only examples and may differ from the equipment in your truck.

Operation

4

Display messages

The seat switch is not actuated while the accelerator pedal or steering wheel is actuated

The accelerator pedal or the steering wheel is actuated, even though no one is sitting in the driver's seat. The message SEAT SWITCH appears on the display. The truck will not move.

- Sit in the driver's seat and fasten the seat belt.

The truck can be driven again without restrictions.

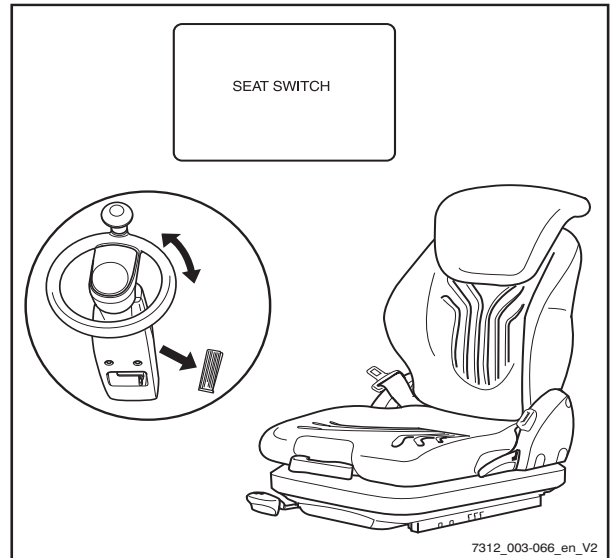

The seat switch is not actuated while the operating device for the working hydraulics is actuated

An operating device for the working hydraulics is actuated, even though no one is sitting in the driver's seat. The message SEAT SWITCH appears on the display. The working hydraulics functions cannot be executed.

- Sit in the driver's seat and fasten the seat belt.

The working hydraulics can be operated again.

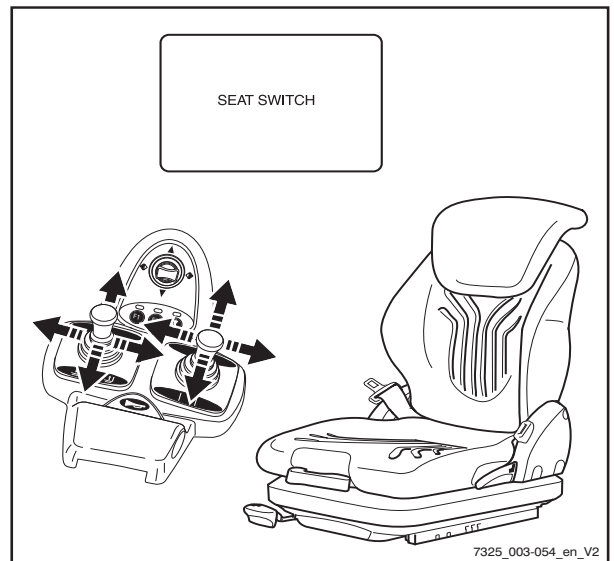

4 Operation

Display messages

The shift time has been exceeded

i NOTE

The shift time is adjustable.

If the key switch is switched on and the driver does not leave the seat before the set shift time is exceeded, SEAT SWITCH appears on the display. This is also the case if an operating device for the working hydraulics or the accelerator pedal is actuated. Depending on the configuration, the working hydraulic functions can be executed normally, only slowly or not at all.

- Stand up briefly from the seat, sit back down again and fasten the seat belt.

The truck can again be operated without restrictions.

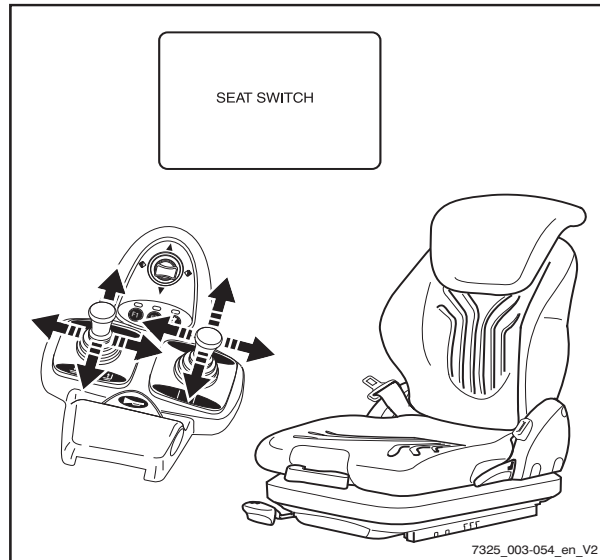

The operating time has been exceeded

i NOTE

The operating time is adjustable.

If the key switch is switched on, the parking brake is released and the driver does not leave the seat before the set operating time is exceeded, and if neither the operating devices for the working hydraulics nor the accelerator pedal are actuated during this time, SEAT SWITCH appears on the display. The truck will not move. Depending on the configuration, the working hydraulic functions can be executed normally, only slowly or not at all.

- Stand up briefly from the seat, sit back down again and fasten the seat belt.

The truck can again be operated without restrictions.

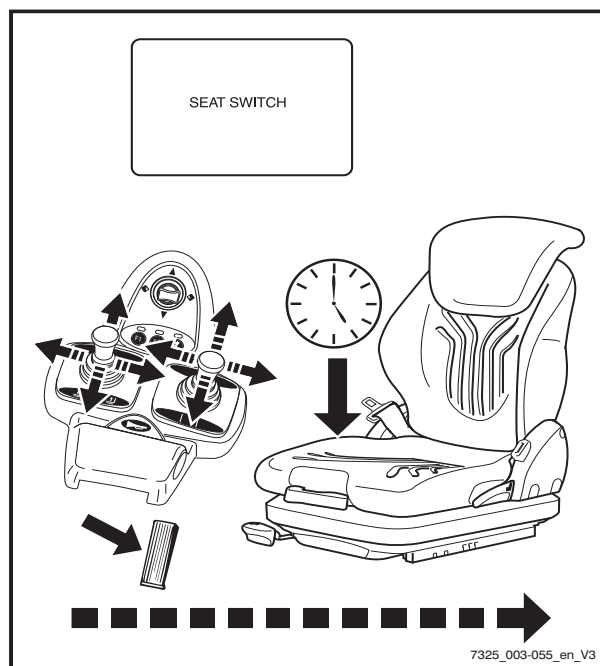

OVERHEATING message

If the message OVERHEATING appears on the display, the traction motors have overheated. The acceleration and the speed of the truck are reduced.

- Allow the truck to cool down.
- If the error persists, contact your authorised service centre.

SURVEILLANCE message

If the SURVEILLANCE message appears in the display, there is a fault in the process monitoring.

This shuts off the drive unit.

- Switch the key switch to the "0" position and then back to the "I" position.
- Start the engine.
- Release accelerator pedal.
- Select the drive direction again.

NOTE

If this error occurs sporadically, it can be tolerated. If the operational capacity is impaired, notify your authorised service centre.

NOT VALID message

If the message NOT VALID appears on the display, an incorrect driver PIN has been entered when entering the access code.

- Once the message goes out, enter the driver PIN again.

Drive-specific messages

Message ! PARKING BRAKE OIL PRESSURE

If the following message appears in the display when the accelerator pedal is actuated:

! PARKING BRAKE OIL PRESSURE, the service brake of the truck is not yet ready for use.

The driving speed is limited to 5 km/h.

When the service brake is ready for operation, the message disappears. The speed limitation is cancelled.

MOT/GEN.-TEMP. message

If the MOT/GEN. -TEMP. message appears, the traction motor or the generator is overheated or a cable is broken.

Display messages

- Interrupt work and allow the truck to cool down. Do not switch off the key switch.

NOTE

If the operational capacity is impaired, notify your authorised service centre.

OVERHEATING message

If the message OVERHEATING appears in the display, the traction motors have overheated. The acceleration and the speed of the truck are reduced.

- Allow the truck to cool down.
- If the error persists, contact your authorised service centre.

CLOSE THE DOOR message

If the message CLOSE THE DOOR (variant) appears in the display, the battery door is not shut correctly. The truck will not move.

- Close the battery door.

LEVER message

If an operating device is actuated continuously for a long period, the Lever message is displayed with the error code A4601...4604. If you continue to move the operating device, the affected hydraulic function is switched off. The message disappears as soon as the operating device is released. The hydraulic function is available again.

- Release the operating device.

LIFT HEIGHT message

Speed limitation with a raised load (variant)

This function makes sure that the truck can only move slowly when a load is lifted.

⚠ DANGER

Risk of accident!

Before using this function, familiarise yourself with the altered driving characteristics of the truck!

Optionally, the truck can have altered acceleration behaviour and/or braking characteristics.

⚠ DANGER

Risk of accident!

Driving with a lifted load is prohibited because the truck can overturn due to the high centre of gravity.

Because the limits determined by physics cannot be altered, the increased safety provided by this function must not be misused in order to take safety risks.

If the fork is raised above a certain height, the following happens:

Lifting the load at a standstill

The key switch is switched on. The driver sits on the seat with the belt fastened. The load is lifted. The display briefly shows the flashing message **LIFT HEIGHT**. The truck will only travel at a reduced driving speed.

- Lower the fork (load) to just above the ground.

The truck can now be driven again with no speed limitation.

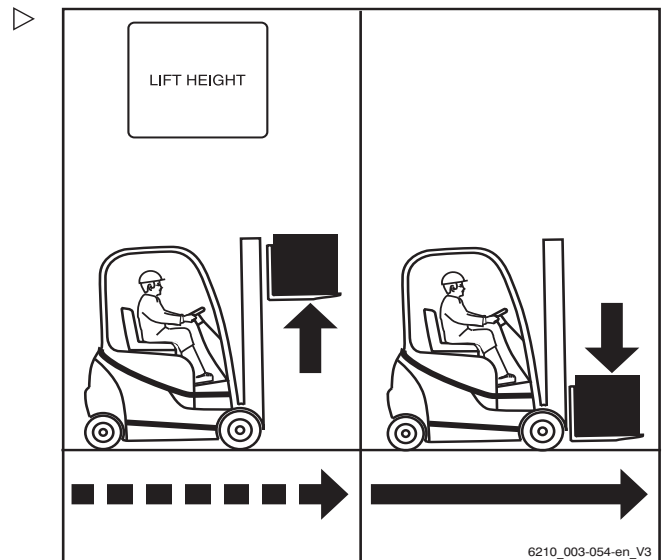

6210_003-054-en_V3

4 Operation

Display messages

Lifting the load while driving

If you are travelling with the load during a stacking/unstacking operation and lift the load while travelling, the flashing message **LIFT HEIGHT** appears briefly in the display. The truck will travel slowly or will be braked.

- Lower the fork (load) to just above the ground.

The truck can now be driven again with no speed limitation.

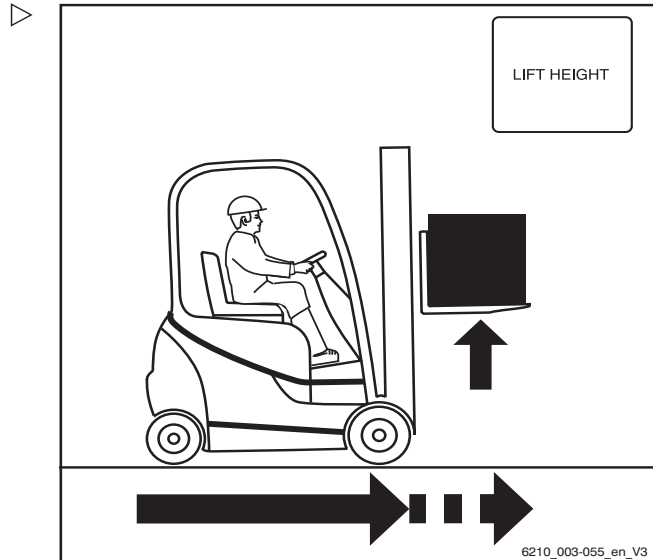

Procedure in emergencies

Emergency shutdown

⚠ WARNING

No electric braking assistance is available when the emergency off switch is actuated!

Actuating the emergency off switch will disconnect the drives from the power supply. The truck will not be held on a slope by the electric brake.

- To brake, actuate the service brake.

⚠ CAUTION

Actuating the emergency off switch (1) or disconnecting the battery male connector (2) shuts down the electrical functions of the truck.

- Only use this safety system in the event of an emergency.

⚠ CAUTION

Risk of component damage!

If you disconnect the battery male connector while the key switch is switched on (under load), an arc will be produced. This can lead to erosion at the contacts, which considerably shortens their service life.

- Switch off the key switch before disconnecting the battery male connector.
- Do not disconnect the battery male connector while the key switch is switched on, except in an emergency.

In an emergency, all functions of the truck can be shut down:

- Press the emergency off switch (1) or disconnect the battery male connector (2).

Pressing the emergency off switch has the following effect in drive mode:

- No reduction in truck speed when the accelerator pedal is released, according to the drive program selected. The truck will coast
- In trucks with an electric parking brake (variant), the electric parking brake is applied as soon as the truck comes to a stop
- The electric brake does not function during the first part of brake pedal travel. To brake

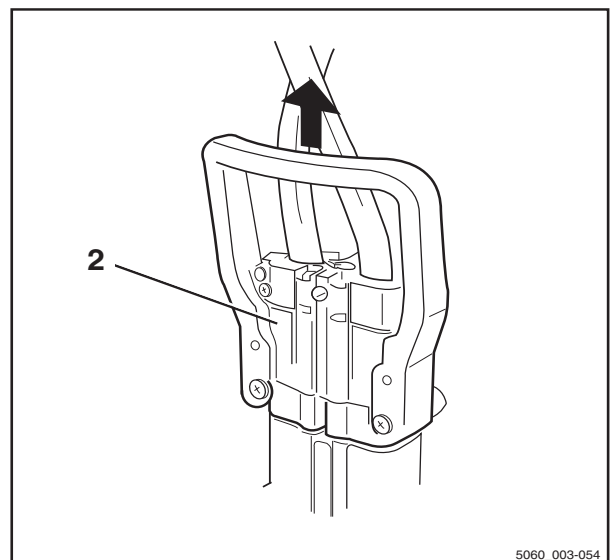
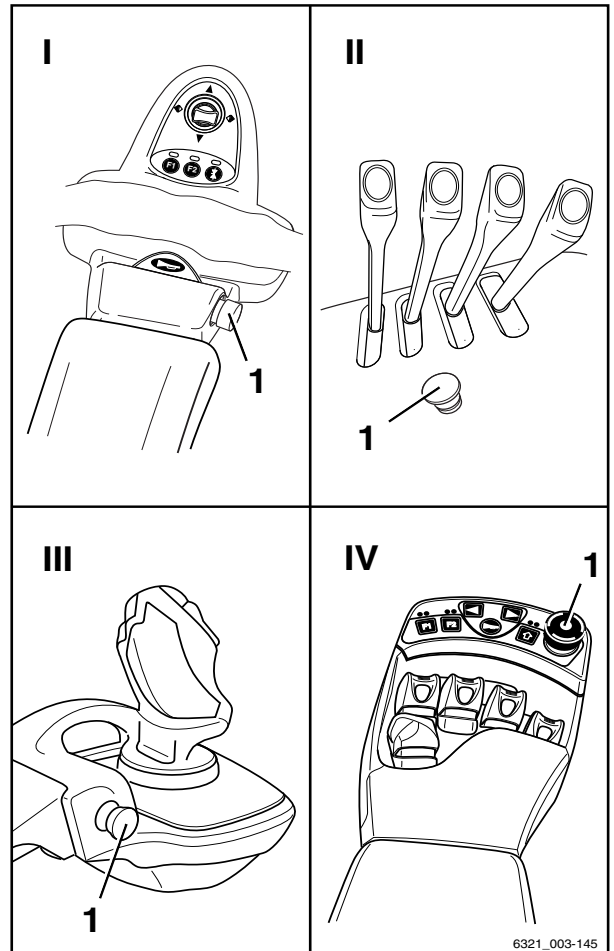

4 Operation

Procedure in emergencies

- the truck using the mechanical brake, the brake pedal must be pushed down further
- The truck can only be held on a slope using the mechanical brake, not the electric brake
- No power steering effect; the steering forces are increased by the remaining emergency steering function
- The "Curve Speed Control" system (automatic reduction in truck speed when cornering) does not function The truck must be decelerated with the mechanical brake by pressing the brake pedal
- No hydraulic functions are available

Procedure if truck tips over

⚠ DANGER

If the truck tips over, the driver could fall out and slide under the truck with potentially fatal consequences. There is a risk to life.

Failure to comply with the limits specified in these operating instructions, e.g. driving on unacceptably steep gradients or failing to adjust speed when cornering, can cause the truck to tip over. If the truck starts to tip over, do not leave the truck under any circumstances. This increases the danger of being hit by the truck.

- Do not release your seat belt.
- Never jump off the truck.
- You must adhere to the rules of behaviour if the truck tips over.

Rules of behaviour if truck tips over:

- Hold onto the steering wheel with your hands.
- Brace your feet in the footwell.
- Bend your upper body over the steering wheel.
- Bend your body against the direction of the fall.

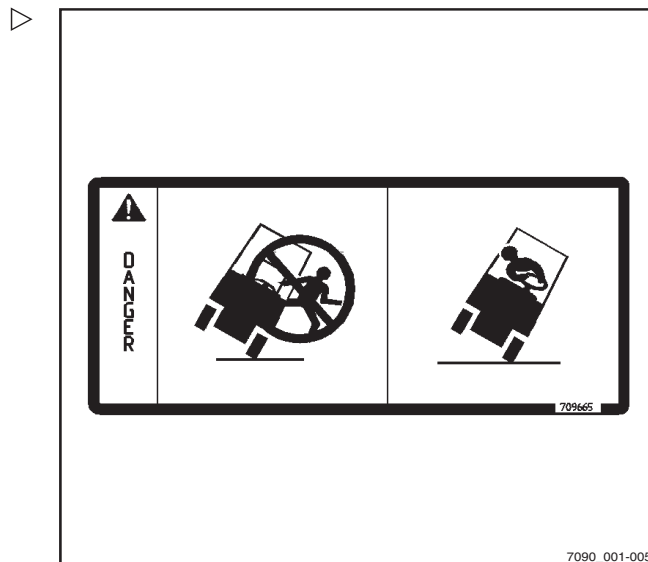

Emergency hammer

The emergency hammer is used to rescue the driver if he is shut inside the cab in a hazardous situation, for example if the truck has toppled over and the cab door cannot be opened.

Single-pane safety glass can be struck relatively safely using the emergency hammer in order for the driver to escape or be rescued from the danger area.

Using the emergency hammer

WARNING

When glass is smashed there is a risk of injury caused by glass splinters!

When the cab glass is smashed, splinters of glass can shoot into the face and cause damage to skin and eyes through cuts. When a pane of glass is smashed, the face should be turned away and covered with the crook of the free arm.

- Protect the face when smashing a pane of glass.
- Pull the emergency hammer out of its support mounting at the handle.
- Using one of the two metal tips on the head of the emergency hammer, hit the pane of glass with force until it breaks.

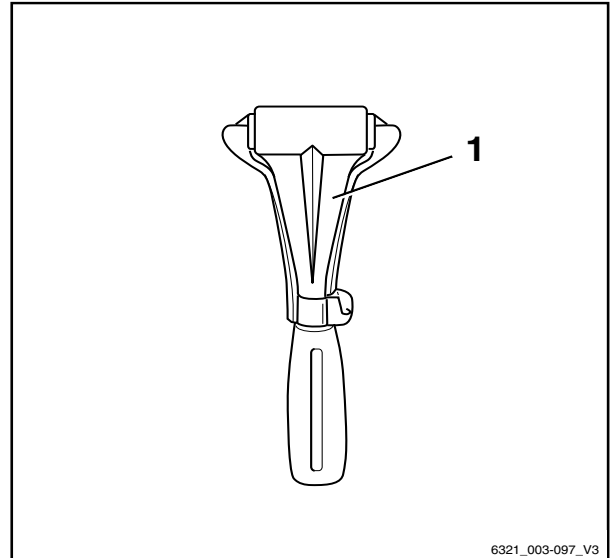

Emergency lowering

If the hydraulic controller fails whilst a load is raised, emergency lowering can be performed. An emergency lowering screw for this purpose is located on the valve block.



DANGER

There is a risk of fatal injury from falling loads or parts of the truck being lowered.

- Do not walk beneath the raised load.
 - Adhere to the following steps.
-
- Remove the valve cover.

4

Operation

Procedure in emergencies

- Remove the hexagon socket wrench (1) from the compartment on the right next to the driver's seat.

i NOTE

In this procedure, a distinction is made between the types of operating devices.

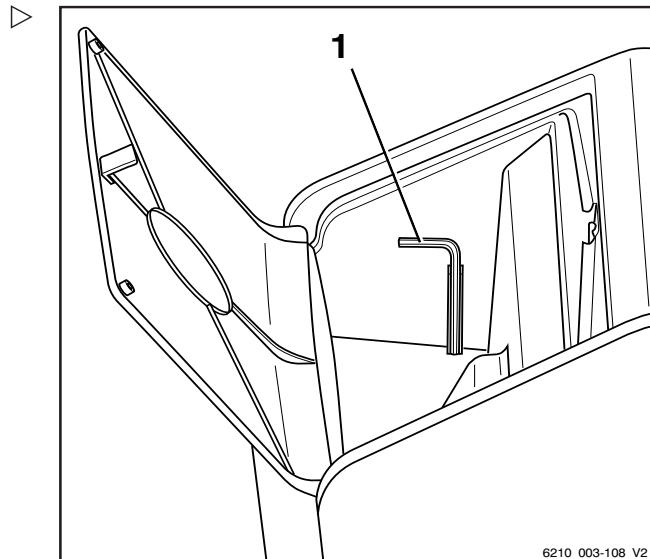

For the Joystick 4Plus version and the mini-lever version (A):

- Using the hexagon socket wrench, turn the emergency lowering screw (2) on the valve block (5) a maximum of 1.5 revolutions to loosen it.

For the multiple-lever version (B):

- Using the hexagon socket wrench (1), turn the emergency lowering screw (4) on the valve block (3) a maximum of 1.5 revolutions to loosen it.

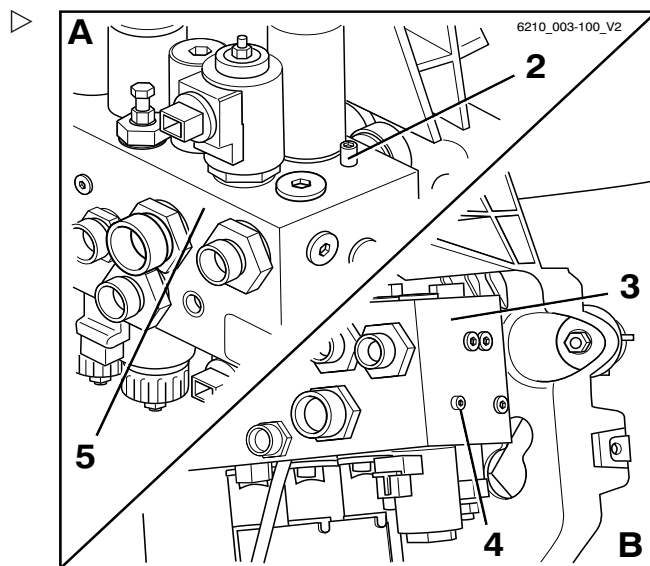

A Joystick 4Plus version and mini-lever version:
B Multiple-lever version

⚠ WARNING

The load is lowered!

The lowering speed is regulated by unscrewing the emergency lowering screw.

- Note the following list.

For both versions:

- Tightening torque:
max. 2.5 Nm
- When unscrewed a little:
The load lowers slowly
- When unscrewed a lot:
The load lowers quickly

After lowering:

- Screw the emergency lowering screw for the load back in.

Operation

4

Procedure in emergencies

- Return the hexagon socket wrench to the support mounting in the compartment.
- Install the valve cover.

⚠ DANGER

If the truck is operated with the hydraulic controller blocked, there is an increased risk of accidents!

- After the emergency lowering procedure, have the malfunction rectified.
- Notify the authorised service centre.

Emergency operation of the electric parking brake

⚠ WARNING

The truck can roll away when the parking brake is released!

Emergency operation of the parking brake can be initiated only when the fork is lowered and the truck is switched off.

In emergency operation or during transport without a battery, the electric parking brake can be operated manually via the hand wheel.

- Lower the forks to the ground.
- Switch off the key switch.
- Lift cover (3) and move it to the side.
- Remove hand wheel (4) and place upside down on the tappet.

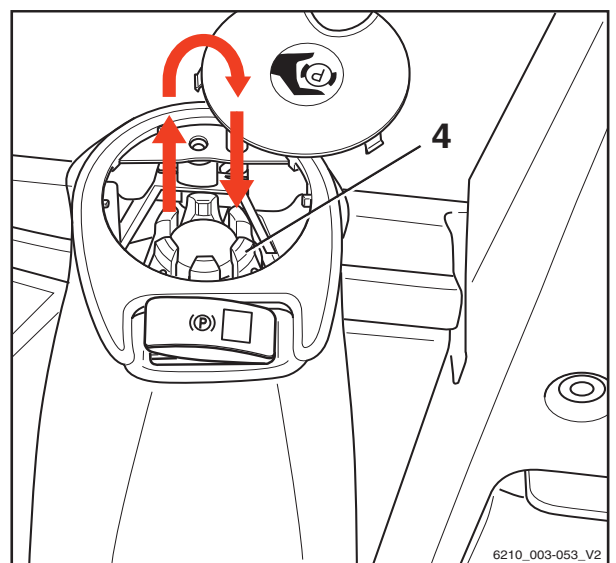
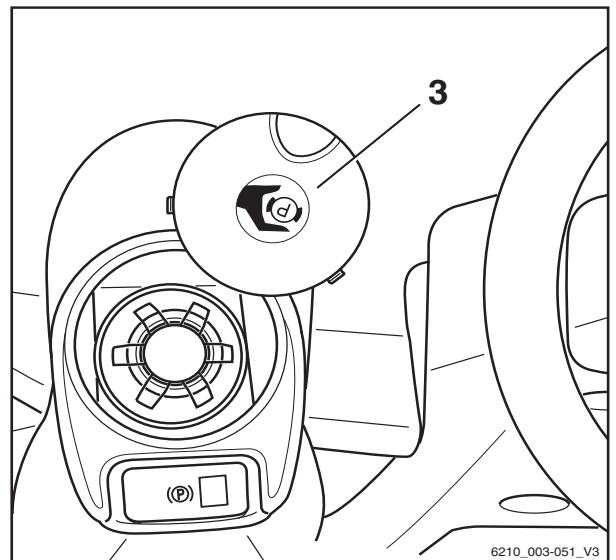

4 Operation

Procedure in emergencies

- Place the hand wheel with the tappet lugs (5) on the tappet (6) and press down against the spring force.

i NOTE

Do not rotate the hand wheel to the stop, because this will trigger the relubrication device.

- To apply the parking brake rotate the hand wheel clockwise until the force needed increases markedly and the truck is held securely. The effort required is not great.
- To release the parking brake rotate the hand wheel anticlockwise a maximum of 5 revolutions until the hand wheel can be turned easily.

After manual operation, the hand wheel is to be returned to its latch position and the cover to its normal position.

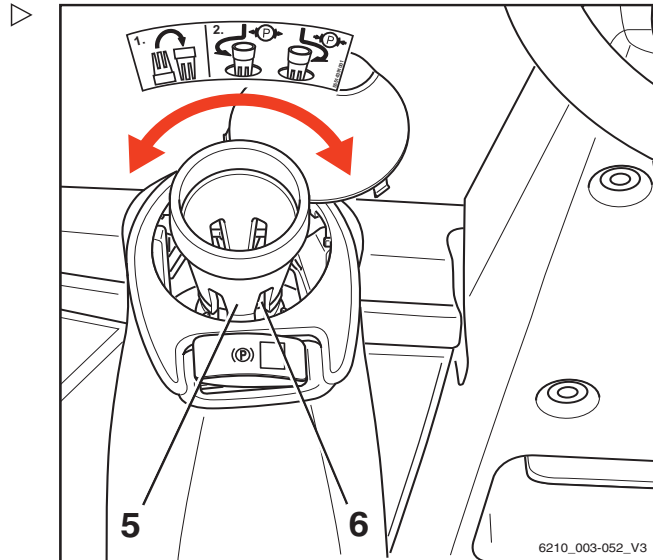

Towing

⚠ DANGER

The brake system on the towing vehicle may fail. There is a risk of accident!

If the brake system of the towing vehicle is not adequately sized, the vehicle may not brake safely or the brakes may fail. The towing vehicle must be able to absorb the pulling and braking forces from the unbraked towed load (total actual weight of the truck).

- Check the pulling and braking forces of the towing vehicle.

⚠ DANGER

The truck could drive into the towing vehicle when the towing vehicle brakes. There is a risk of accident!

If a rigid connection has not been used for power transmission in two directions during towing, the truck may drive into the towing vehicle when the towing vehicle brakes. For safety reasons, only a tested tow bar may be used.

- Use a tested tow bar.

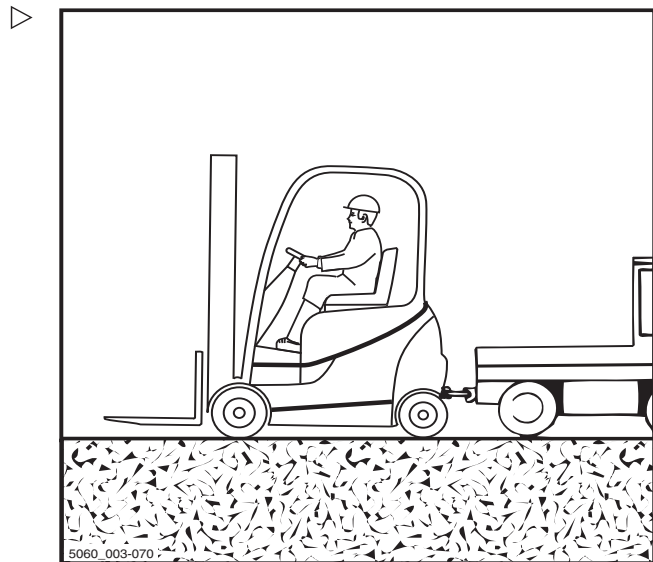



⚠ CAUTION

If the drive of the truck between the drive motor and the drive axle is not interrupted, the drive may be damaged.

- Place the drive direction switch in the neutral position.

⚠ CAUTION

Risk of component damage!

If you remove the battery male connector with the key switch switched on (under load), an arc will be produced. This can lead to corrosion at the contacts, which considerably shortens their service life.

- Do not disconnect the battery male connector while the key switch is switched on.

⚠ DANGER

People can be crushed between the truck and towing vehicle during manoeuvring. There is danger of death!

The towing vehicle may only be manoeuvred and the tow bar may only be attached using a second person as a guide. This ensures that the driver of the towing vehicle and the mechanic attaching the tow bar are aware of possible risks.

- Only manoeuvre with a guide.

⚠ CAUTION

Steering is stiff! There is no power steering if the hydraulics fail!

- The selected towing speed must allow the truck and towing vehicle to be effectively braked and controlled at all times.

⚠ CAUTION

If the truck is not steered while it is being towed, it may veer out in an uncontrolled manner!

- The truck being towed must also be steered by a driver.
 - The driver of the truck being towed must sit in the driver's seat and fasten the seat belt before towing.
 - Where possible, activate the restraint systems provided.
-
- Set down load and lower fork arms close to the ground.



4 Operation

Procedure in emergencies

- Place the drive direction switch in the neutral position.
- Apply the parking brake.
- Switch off the key switch.
- Disconnect the battery male connector.
- Check the pulling and braking forces of the towing vehicle.
- With the help of a guide, attach the towing vehicle to the truck.
- Secure the tow bar to the tow coupling of the towing vehicle and the truck.
- Sit in the driver's seat in the truck to be towed, and fasten the safety belt.
- Where possible, activate the restraint systems provided.
- Release the parking brake.
- Select a towing speed that allows the truck and towing vehicle to be effectively braked and controlled at all times.
- Tow the truck.
- After towing, secure the truck from rolling away (e.g. by applying the parking brake or using chocks).
- Remove the tow bar.

Connecting and disconnecting the battery male connector

Connecting the battery male connector ▷

- Open the battery cover.

⚠ CAUTION

Potential for damage to the battery male connector!
If the battery male connector is connected while the key switch is on (under load), a jump spark will be produced. This jump spark can damage the contacts and considerably shorten the service life of the contacts.

- Do not connect the battery male connector with the key switch switched on.
 - Make sure that the key switch is switched off before connecting the battery male connector.
-
- Ensure that the battery male connector (1) and the plug connection are dry, clean and free of foreign objects.
 - Insert the battery male connector (1) fully into the plug connection on the truck.

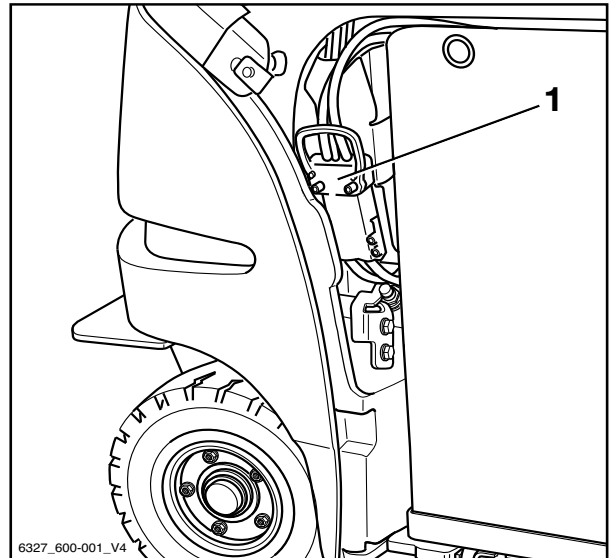

6327_600-001_V4



⚠ CAUTION

There is a risk of short circuit if the cables are damaged.

Do not crush the battery cable when closing the battery cover.

- Ensure that the battery cable does not come into contact with the battery cover.

- Close the battery cover.

Connecting and disconnecting the battery male connector

Disconnecting the battery male connector

⚠ CAUTION

Risk of component damage!

If you remove the battery male connector when the key switch is switched on (under load), an arc will be produced. This can lead to erosion at the contacts, which considerably shortens their service life.

- Switch off the key switch before the battery male connector is disconnected.
- Only disconnect the battery male connector with the key switch switched on in an emergency.

- Open the battery cover.
- Disconnect the battery male connector (1) by pulling in the direction of the arrow at the plug connection.
- Place the battery male connector on the battery.

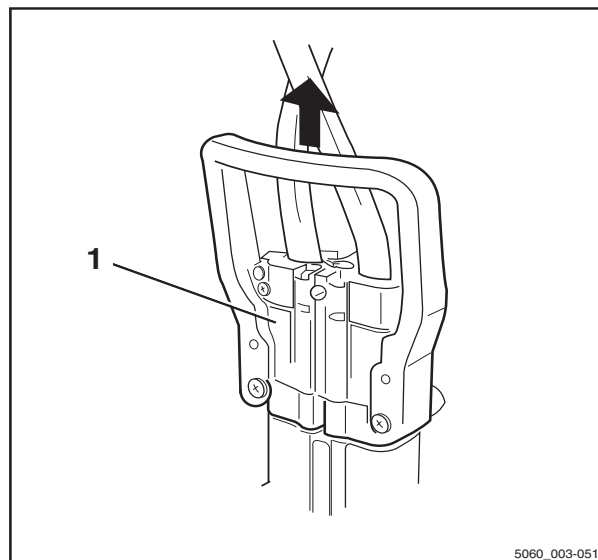

5060_003-051



⚠ CAUTION

There is a risk of short circuit if the cables are damaged.

Position the battery cable on the battery in such a way that it cannot be crushed when removing or inserting the battery or when closing the battery cover.

- Check the connecting cable for damage.
- Ensure that the battery cable does not come into contact with the battery cover.

- Close the battery cover.

Handling the lead-acid battery

Safety regulations for handling the battery

- National statutory provisions for the country of use must be followed when setting up and operating battery charging stations.



⚠ CAUTION

Risk of component damage!
Incorrect connection or incorrect operation of the charging station or battery charger may result in damage to components.

- Follow the operating instructions for the charging station or battery charger and for the battery.

- Observe the following safety regulations when maintaining, charging and changing the battery.

Maintenance personnel

Batteries may only be charged, maintained or replaced by properly trained personnel in accordance with the instructions from the manufacturers of the battery, battery charger and truck.

- Follow the handling instructions for the battery and the operating instructions for the battery charger.



⚠ WARNING

Risk of crushing/shearing!
The battery is very heavy. There is a risk of serious injury if any parts of the body are caught under the battery.

There is a risk of injury if any parts of the body are wedged between the battery cover and the edge of the chassis when the battery cover is closed.

- Always wear safety shoes when replacing the battery.
- Only close the battery cover if there is no part of the body between the battery cover and the edge of the chassis.

Handling the lead-acid battery

The battery must only be replaced in accordance with the directions in these operating instructions.

- When charging and maintaining the battery, observe the manufacturer's maintenance instructions for the battery and the battery charger.

Fire protection measures



⚠ DANGER

Risk of explosion due to flammable gases!

During charging, the battery releases a mixture of oxygen and hydrogen (oxyhydrogen gas). This gas mixture is explosive and must not be ignited.

There must be no flammable materials or spark-forming operating materials within 2 m of either the truck when it is parked for charging or the battery charger.

- When working with batteries, take the following safety precautions.
- Keep away from open flames and do not smoke.
- Ensure that work areas are adequately ventilated.
- Disconnect the battery male connector before charging and only when the truck and battery charger are switched off.
- The battery cover must remain open during charging.
- Expose the surfaces of the battery cells.
- Do not place any metal objects on the battery.
- Fully open any protective structures (e.g. fabric-covered cab).
- Have fire extinguishing equipment ready.



Battery weight and dimensions

⚠ DANGER

Risk of tipping due to change in battery weight!

The battery weight and dimensions affect the stability of the truck. When replacing the battery, the weight ratios must not be changed. The battery weight must remain within the weight range specified on the nameplate.

- Do not remove or change the position of ballast weights.
- Note the battery weight.

Performing battery maintenance

The cell covers of the battery must be kept dry and clean.

Terminals and cable shoes must be clean, lightly coated with battery grease and screwed on tightly.

- Neutralise any spilt battery acid immediately.
- Observe the safety regulations for handling battery acid; see the chapter entitled "Battery acid".

4

Operation

Handling the lead-acid battery

Damage to cables and battery male connectors



CAUTION

There is a risk of short circuit if the cables are damaged.

Do not crush the battery cable when closing the battery cover.

- Check the battery cable for damage.
- When removing and reinstalling the battery, ensure that the battery cables are not damaged.
- Ensure that the battery cable does not come into contact with the battery cover.

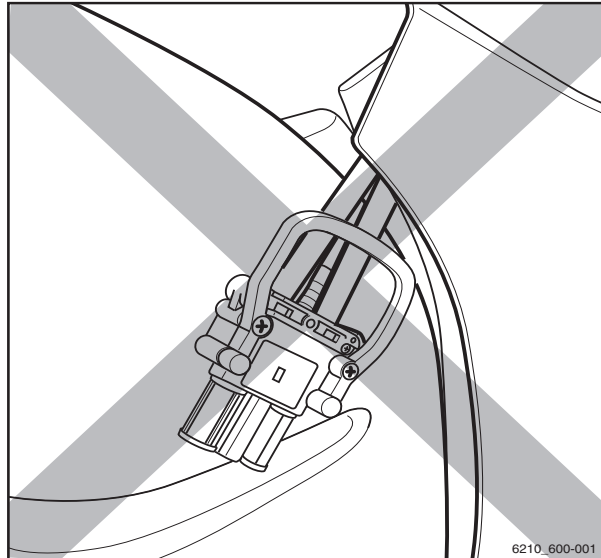

6210_600-001

CAUTION

Potential for damage to the battery male connector!

If the battery male connector is disconnected or connected while the key switch is switched on or while the battery charger is under load, an arc or a transition spark will be produced at the battery male connector. This can lead to erosion at the contacts and can considerably shorten the service life of the contacts.

- Switch off the key switch or the battery charger before the battery male connector is disconnected or connected.
- Do not disconnect the battery male connector while under load, except in an emergency.

Maintaining the battery

DANGER

Risk to life!

- Observe the chapter "Safety regulations for handling the battery".

WARNING

Battery acid is toxic and corrosive!

- Observe the safety regulations in the "Battery acid" chapter.

**i** NOTE

Battery maintenance is carried out in accordance with the battery manufacturer's operating instructions! The operating instructions for the battery charger must also be followed. Only the instructions that came with the battery charger are valid. If any of these instructions are not available, please request them from the dealer.

The battery maintenance is composed of the following sections "Checking the battery condition, acid level and acid density", "Checking the battery charge status", "Charging the battery" and "Equalising charge to prevent a deep discharge of the battery" together.

Handling the lead-acid battery

Checking the battery condition, acid level and acid density



⚠ WARNING

The electrolyte (dilute sulphuric acid) is poisonous and caustic!



- Observe safety regulations for handling battery acid; see chapter "Battery acid".
- Wear personal protective equipment (rubber gloves, apron and protection goggles).
- Rinse away spilt battery acid immediately with plenty of water!

⚠ CAUTION

Risk of damage!

- Heed the information in the operating instructions for the battery.
 - Remove the battery from the truck.
 - Inspect battery for cracked housing, raised plate sand acid leaks.
 - Have defective batteries repaired by the authorised service centre.
 - Open filler cap (1) and check the acid level. ▷
- For batteries with "caged cell plugs", the liquid must reach the bottom of the cage.
- For batteries without "caged cell plugs", the liquid must reach a height of approx. 10 to 15 mm above the lead plates.
- Top up missing fluid with distilled water only.
 - Clean the battery cell cover and dry if necessary.
 - Remove any oxidation residues on the battery terminals and then apply acid-free grease to the terminals.
 - Tighten the battery-terminal clips (2) to a torque of 22–25 Nm (depending on the size of the terminal screws used).
 - Check acid density with an acid siphon.

After charging, the acid density must be between 1.28 and 1.30 kg/l.

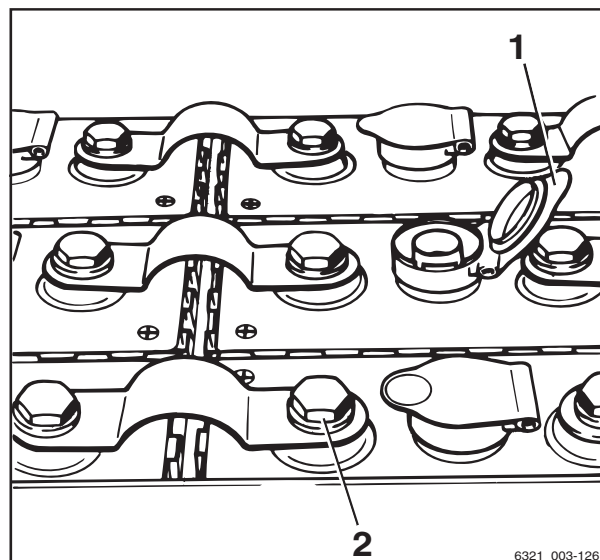

6321_003-126

For a discharged battery, the acid density must be **no lower** than 1.14 kg/l.

Checking the battery charge status

⚠ CAUTION

Deep discharges shorten the service life of the battery.

If no bar is shown in the battery charge display (1) (0% of the available battery capacity, i.e. around 20% of the nominal capacity), deep discharge begins.

- Avoid deep discharges (no bar on the display) (see the section entitled "Equalising charge to prevent a deep discharge of the battery").
- Cease work with the truck immediately.
- Charge the batteries immediately.
- Do not leave batteries in a discharged or partly discharged state.

- Apply the parking brake.
- Switch on the key switch.
- Read the charge state (1) from the display.
- Charge a discharged or partly discharged battery.

i NOTE

The battery charge display shows the available battery capacity as a segmented bar graph in 10% increments. Approx. every 10 seconds, the display switches between the battery charge and the remaining period.

Charging the battery

⚠ DANGER

Danger to life and limb!

- Observe the instructions in the chapter entitled "Safety regulations when handling the battery".

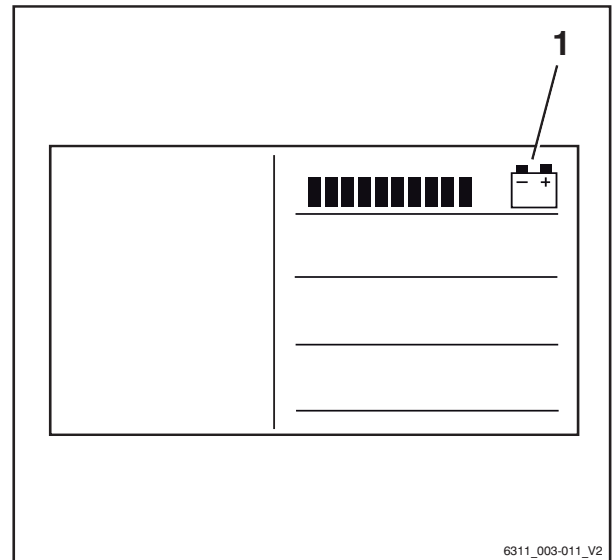

4 Operation

Handling the lead-acid battery

⚠ WARNING

Battery acid is toxic and corrosive!

- Observe the safety regulations in the chapter entitled "Battery acid".



⚠ CAUTION

Risk of component damage!
Incorrect connection or operation of the charging station or battery charger may result in damage to components!

- Follow the operating instructions for the charging station or battery charger and for the battery.

⚠ CAUTION

Possibility of damaging the battery male connectors!
Ensure that the key switch or battery charger is switched off before the battery male connectors are disconnected or connected.

i NOTE

Battery maintenance is carried out in accordance with the battery manufacturer's operating instructions! The operating instructions for the battery charger must also be followed. Only the instructions that came with the battery charger are valid. If any of these instructions are missing, please request them from the dealer.

To read the battery charging state, see the section entitled "Checking the battery charge status".

- Park the truck securely.
- Open any protective structures fully (e.g. fabric-covered cab).
- Open battery cover completely.
- Do not place any metal objects or tools on the battery.
- Keep away from open flames and do not smoke.
- Check the battery cable and the charging cable for damage, and have them replaced

Operation

4

Handling the lead-acid battery

by the authorised service centre if necessary.

- Disconnect the battery male connector (2) by pulling the handle.



⚠ DANGER

Explosive gases are generated during charging!

- Ensure that work areas are adequately ventilated.
- For trucks with a cab (including fabric-covered cabs), ensure adequate ventilation in the cab (variant).

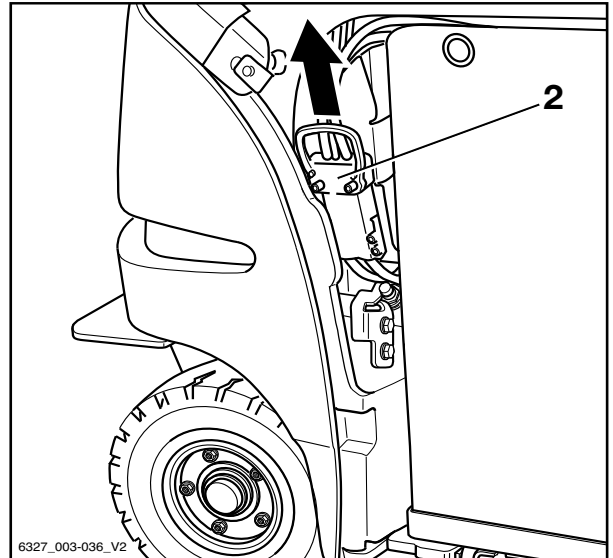

- Attach the battery male connector (3) to the battery charger connector.

i NOTE

Follow the information in the operating instructions for your battery and the battery charger (equalising charge).

- Start the battery charger.
- The ventilation gaps between the cover and chassis must not be blocked.



⚠ DANGER

Risk of explosion!

The battery cover must be kept open during charging to ensure adequate ventilation.

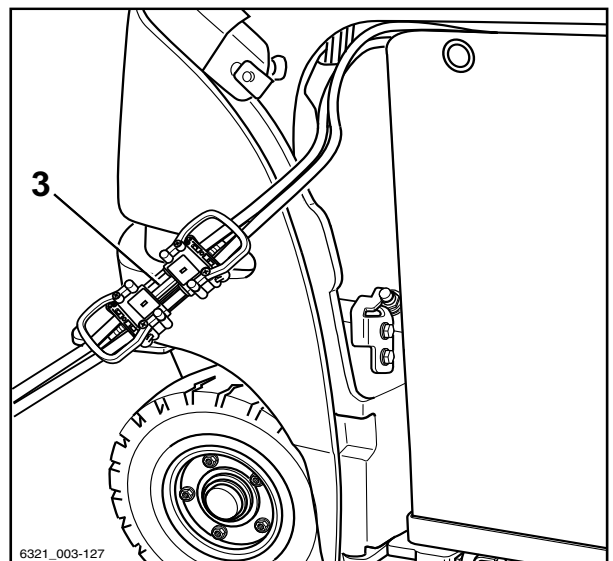

After charging

- Switch off the battery charger.
- Disconnect the battery male connector from the battery charger plug.

4 Operation

Handling the lead-acid battery

- Insert the battery male connector (1) fully into the plug connection on the truck.



CAUTION

There is a risk of short circuit if the cables are damaged.

Do not crush the battery cable when closing the battery cover.

- Ensure that the battery cable does not come into contact with the battery cover.

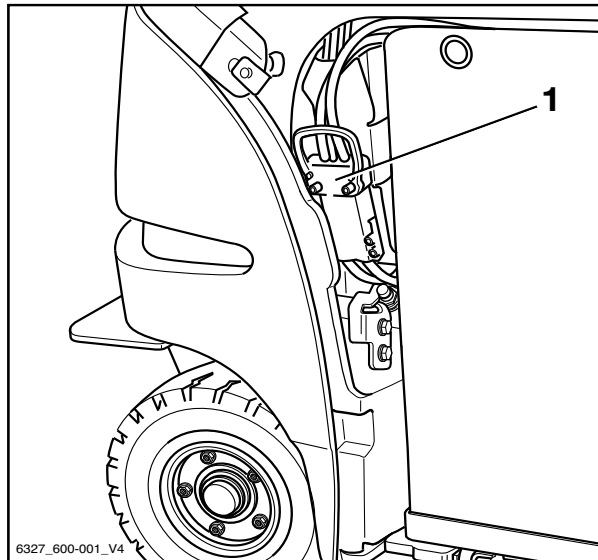

6327_600-001_V4

- Close the battery cover completely. When doing so, ensure that no cables are crushed between the chassis and the cover.

The battery cover must be locked, otherwise the CLOSE THE DOOR error message will appear in the display and the truck will not drive.

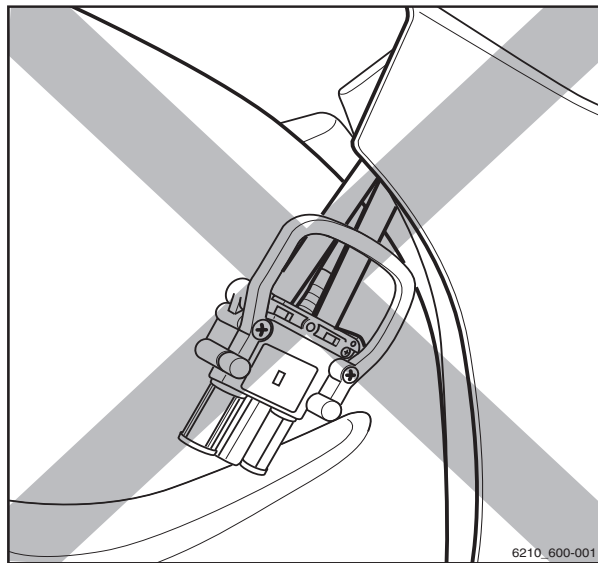

6210_600-001

Charging the battery with the battery charging flap

DANGER

Risk of explosion!

- Observe the safety regulations when handling the battery; see the chapter entitled "Safety regulations for handling the battery".

NOTE

Battery maintenance is carried out in accordance with the battery manufacturer's opera-

ting instructions. The operating instructions for the battery charger must also be followed. Only the instructions that came with the battery charger are valid. If any of these instructions are not available, please request them from the dealer.

Battery charging flap (variant)

- Park the truck safely.
- Press the release buttons (1).

The release buttons (1) pop out.

- Turn the release buttons (1).

The release buttons (1) unlock the battery charging flap (2).

- Open the battery charging flap (2) fully.

⚠ CAUTION

Potential for damage to the battery male connector!
If the battery male connector is disconnected while the key switch is on (under load), an arc will be produced. This can lead to erosion at the contacts, which considerably shortens the service life of the contacts.

- Switch off the key switch before disconnecting the battery male connector.
- Do not disconnect the battery male connector while the key switch is switched on, except in an emergency.

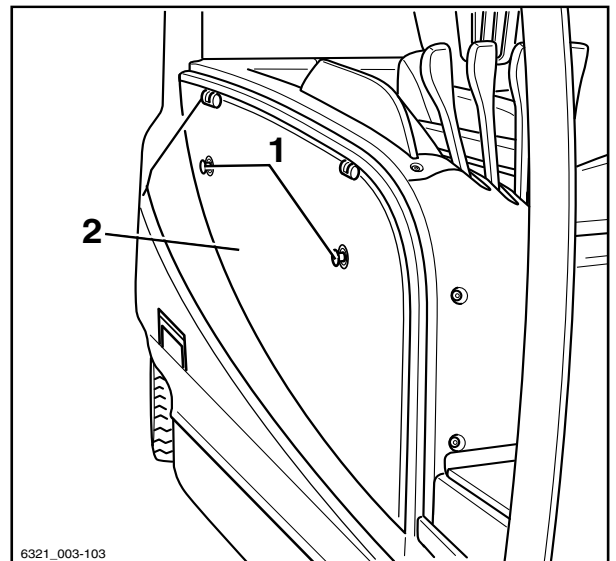

6321_003-103

4 Operation

Handling the lead-acid battery

- Disconnect the battery male connector (3) from the truck.



⚠ DANGER

Explosive gases are generated during charging.

- Ensure that work areas are adequately ventilated.
- For trucks with a cab (including fabric-covered cabs), ensure adequate ventilation in the cab (variant).

⚠ DANGER

There is a risk of damage, short circuiting and explosions!

- Do not place any metal objects or tools on the battery.
- Keep away from open flames and do not smoke.

⚠ WARNING

The electrolyte (diluted sulphuric acid) is poisonous and corrosive!

- Observe safety regulations for handling battery acid; see the chapter entitled "Battery acid".
- Rinse away spilt battery acid immediately using plenty of water!
- Before charging, check the battery cable and the charging cable for damage, and have the cables replaced by the authorised service centre if necessary.

⚠ CAUTION

Damage to the connection assembly is possible!
If the charging cable is connected while the battery charger is switched on (under load), a transition spark will be produced. This transition spark can damage the contacts and considerably shorten the service life of the contacts.

- Switch off the battery charger before you connect the charging cable.
- Ensure that the battery male connector (3) and the plug for the battery charger (4) are dry, clean and free of foreign objects.

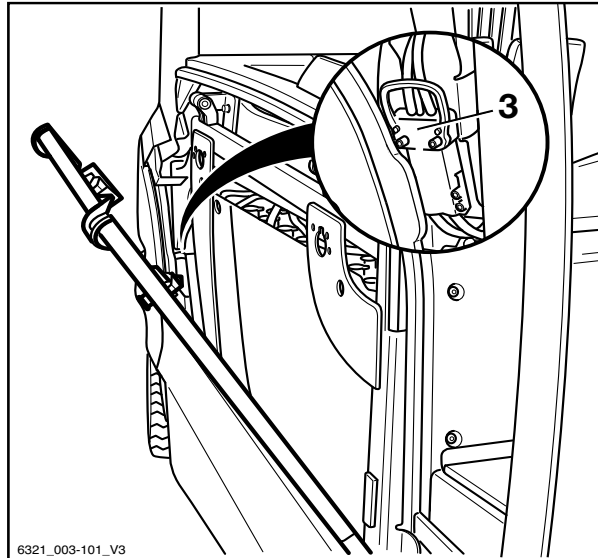

6321_003-101_V3

Operation

4

Handling the lead-acid battery

- Connect the battery male connector (3) to the plug for the battery charger (4).
- Start the battery charger.

i NOTE

Observe the information in the operating instructions for the battery and the battery charger (equalising charge).



⚠ DANGER

Risk of explosion!

In order to ensure sufficient ventilation, the battery charging flap must be kept open during the charging process.

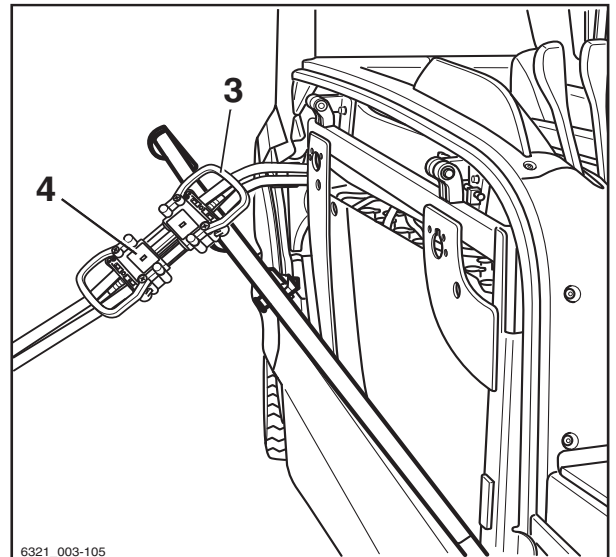

6321_003-105

- The ventilation gap between the flap and chassis must not be blocked.

After charging:

- Switch off the battery charger.

⚠ CAUTION

Damage to the connection assembly is possible! If you pull out the charging cable while the battery charger is switched on, an arc will be produced. This can lead to erosion at the contacts, which considerably shortens the service life of the contacts.

- Switch off the battery charger before you disconnect the charging cable.



⚠ WARNING

Risk of explosion!

The plug may only be disconnected from the socket when the truck and battery charger are switched off.

- Disconnect the battery male connector from the plug for the battery charger.

4 Operation

Handling the lead-acid battery

- Reconnect the battery male connector (3) to the plug connection on the truck. ▷



CAUTION

There is a risk of short circuit if the cables are damaged.
Do not crush the battery cable when closing the battery cover.

- Ensure that the battery cable does not come into contact with the battery cover.

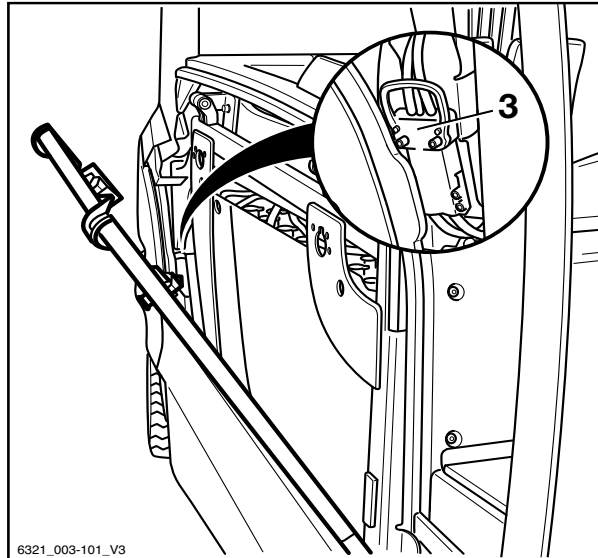

6321_003-101_V3

- Close the battery cover completely. When doing so, ensure that no cables are crushed between the chassis and the cover. ▷

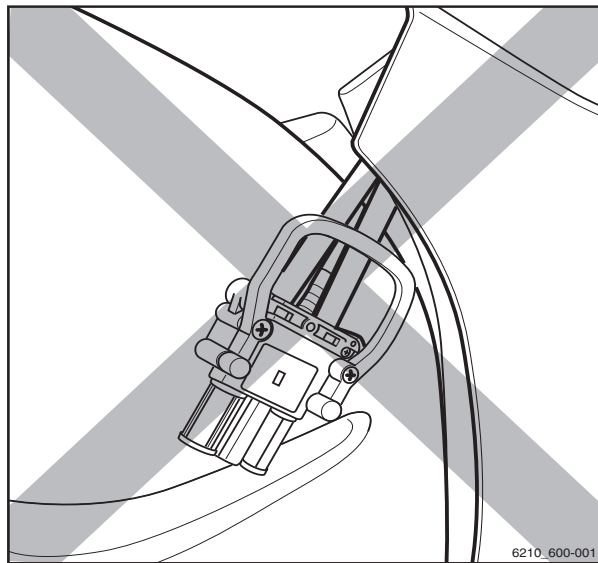

6210_600-001

Equalising charging to preserve the battery capacity

Equalising charges ensure that unevenly charged battery cells are evenly charged again. This preserves the service life of the battery and the battery capacity.

An equalising charge should be carried out in accordance with the battery manufacturer's instructions several times a month after the normal charging process.

 **NOTE**

Depending on the battery charger used, the equalising charge may not begin until 24 hours have elapsed. A period when no shifts are running, such as the weekend, is therefore ideal for performing the equalising charge.

- Observe the information in the operating instructions of the battery charger regarding how to perform an equalising charge.

Starting the equalising charge

- Charge the battery.
- After charging, leave the battery in the charger.

The battery charger remains switched on. Depending on the type of battery charger, the equalising charge begins between 6 and 24 hours after the end of the actual charging process. The equalising charge takes up to 2 hours.

- Please refer to the operating instructions from the manufacturer of the battery charger.

Ending the equalising charge

The equalising charge ends automatically. If the battery is required during this process, you can interrupt the equalising charge by pushing the "stop button" on the battery charger.

- Please refer to the operating instructions from the manufacturer of the battery charger.

 **CAUTION**

Damage to the connection assembly is possible! If you disconnect the charging cable while the battery charger is switched on, an arc will be produced. This can lead to erosion at the contacts, which considerably shortens the service life of the contacts.

- Switch off the battery charger before you disconnect the charging cable.

- Switch off the battery charger.
- Disconnect the battery male connector from the plug for the battery charger.



4

Operation

Handling the lead-acid battery

- Insert the battery male connector fully into the plug connection on the truck.

Handling the lithium-ion battery

Safety regulations for handling the lithium-ion battery

First-aid measures

⚠ WARNING

Risk of injury!

Escaping gases can lead to breathing difficulties.

Course of action required if gases or liquids escape

- Immediately ventilate the area or go out into the fresh air; in more serious cases, call a doctor immediately.

Skin irritation can occur in the event of contact with the skin.

- Thoroughly wash the skin with soap and water.

Eye irritation can occur in the event of contact with the eyes.

- Immediately rinse eyes thoroughly with water for 15 minutes, then consult a doctor.

Maintenance personnel

The lithium-ion battery is virtually maintenance-free and can be charged by the driver.

- If you have any questions, please contact your authorised service centre.
- The handling instruction for the battery and the operating instructions for the battery charger must be followed.
- Observe the following safety regulations when maintaining, charging and changing the battery.

Handling the lithium-ion battery



⚠ WARNING

Risk of crushing/shearing!

The battery is very heavy. There is a risk of serious injury if any parts of the body are caught under the battery.

If parts of the body are wedged between the battery door and the edge of the chassis when the battery door is closed, this could lead to injuries.

- Always wear safety shoes when replacing the battery.
- Only close the battery door if there is no part of the body between the battery door and the edge of the chassis.

The battery must only be replaced in accordance with the directions in these operating instructions.

- When charging and maintaining the battery, observe the manufacturer's maintenance instructions for the battery and battery charger.

Fire protection measures

⚠ DANGER

There is a risk of damage, short circuiting and explosion!

- Do not place any metal objects or tools on the battery.
- Keep away from naked flames and do not smoke.



⚠ DANGER

Increased risk of fire!

Damaged lithium-ion batteries pose an increased fire hazard.

In the event of a fire, large quantities of water are the best option to cool the battery.

- Evacuate the location of the fire as quickly as possible.
- Ventilate the location of the fire well, as the resulting combustion gases are corrosive if inhaled.

- Inform the fire brigade that lithium-ion batteries are affected by the fire.
- Observe the information provided by the battery manufacturer regarding the procedure in the event of a fire.

Battery weight and dimensions

⚠ DANGER

Risk of tipping due to change in battery weight!

The battery weight and dimensions affect the stability of the truck. When replacing the battery, the weight ratios must not be changed. The battery weight must remain within the weight range specified on the nameplate.

- Do not remove or change the position of ballast weights.
- Observe the battery weight.

General safety regulations for lithium-ion batteries

The following safety regulations generally apply to operating lithium-ion batteries.

- Comply with the specifications stated in the safety data sheets of the battery manufacturer.
- Protect the battery against mechanical damage to prevent internal short circuits.
- If batteries have even the slightest external damage, dispose of them in accordance with national regulations for the country in which they are being used.
- Do not expose batteries directly to continuously high temperatures or heat sources, such as direct sunlight.
- Train employees in how to handle lithium-ion batteries correctly.

4 Operation

Handling the lithium-ion battery

Lithium-ion batteries "GGS Li-Ion 80 V BG 7"
36.2 kWh and 118.4 kWh

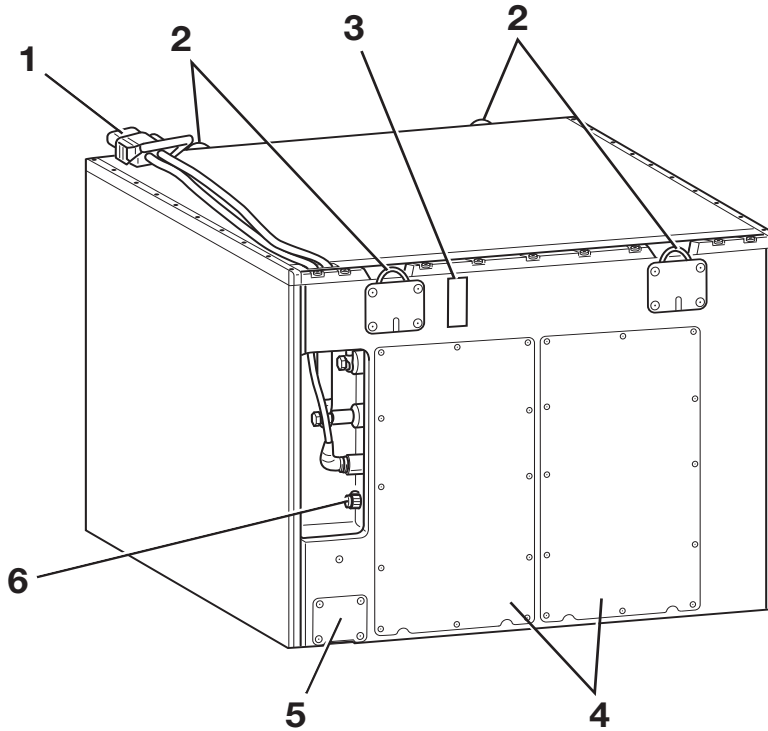

- | | |
|--|---|
| <p>1 Battery male connector
2 Lifting eyes
3 Display</p> | <p>4 Maintenance cover for the technology compartment
5 Safety valve
6 Diagnostic connector</p> |
|--|---|

⚠ WARNING

Risk of accident due to weakened lifting eyes.

If bent lifting eyes are straightened, they lose their rigidity. The lifting eyes are then no longer able to support the weight of the battery. The battery may fall.



- Do not straighten bent lifting eyes.
- Have bent lifting eyes replaced by the authorised service centre.

i NOTE

When switching to lithium-ion batteries, have the truck electronics adapted by the authorised service centre.

Display messages on the display-operating unit

The following table describes the messages that appear on the display-operating unit for the lithium-ion battery:

Message	Meaning	Remedy/reaction
 LITHIUM BATTERY TEMPERATURE	The battery temperature is lower than -15°C or higher than 60°C . If the temperature rises above 60°C , the temperature LED flashes in the battery display. If the temperature rises above 65°C , the temperature LED lights up in the battery display and the truck switches off.	Temperature $< -15^{\circ}\text{C}$: allow the truck to acclimatise in a warmer area. Temperature $> 60^{\circ}\text{C}$: allow the truck to cool down.
 LITHIUM BATTERY RESTRICTION	The truck performance is gradually reduced. The truck goes into emergency operation.	Switch off the truck and then switch it on again. If the error occurs frequently, notify your authorised service centre.
 LITHIUM BATTERY ERROR	The battery has an error and reports it to the truck control unit. The truck switches off after five seconds and rolls to a stop. Within this five-second period, the truck slows down according to the selected gear. The service LED lights up in the battery display.	Notify the authorised service centre.

Regulations for storing lithium-ion batteries

NOTE

Lithium-ion batteries are classified as dangerous goods according to class 9.



Handling the lithium-ion battery

The following recommendations apply:

- Store batteries at a height between 60 cm and 120 cm so that they are not damaged if they fall
- Store the batteries in a segregated area suitable for fire protection (container or safety cabinet)
- Store the batteries at a temperature between +15°C and +30°C and air humidity from 0% to 80%

Observe the following regulations for safe storage of the batteries:

- Store batteries fixed onto pallets and secured against overturning.
- Observe the floor load capacity of the storage area; refer to the manufacturer's specifications regarding battery weight
- To protect batteries against moisture, do not store them directly on the floor
- Due to the fire risk, store batteries outside buildings
- Store in a cool, dry and well-ventilated area
- Never subject the battery to temperatures below -35°C and above 80°C.

Long-term storage below -10°C or above 50°C has a negative impact on the service life of the battery.

- After twelve months, check the charging state of the battery and recharge if necessary
- Cordon off the warehouse area
- Only persons who are aware of the risks and safety regulations may access this area
- Protect against direct sunlight
- Protect against precipitation
- Store in a way that protects the batteries against short circuits
- Store batteries at a safe distance from flammable materials
- Do not store batteries together with metallic objects

**Operation****4****Handling the lithium-ion battery**

- Store lithium-ion batteries separately from other types of batteries (no mixed storage).
- Maintain a safety margin of at least 2.5 m to other goods
- To avoid a deep discharge, observe the specifications of the battery manufacturer regarding the maximum permissible storage period
- If you have any questions, please contact your authorised service centre.

Handling the lithium-ion battery

Checking the battery charge state

The charge state of the lithium-ion battery can be read on the display-operating unit of the truck and on the lithium-ion battery display.

Reading the display-operating unit

- Apply the parking brake.
- Switch on the key switch.
- Read the charge state (1) from the display.
- Charge a discharged or partly discharged battery.

NOTE

The battery charge display shows the available battery capacity as a segmented bar graph in 10% increments. Approx. every 10 seconds, the display switches between the battery charge and the remaining period.

Meaning of the bar graph on the display

- The remaining two bars flash:
The charge state is <30 %.
The battery must be recharged soon.
- No bars are displayed:
The charge state is <15 %.
Charge the battery.
The "Lifting" hydraulic function is slowed down.
The maximum driving speed is limited. This speed can be parameterised specifically for each truck by the authorised service centre.

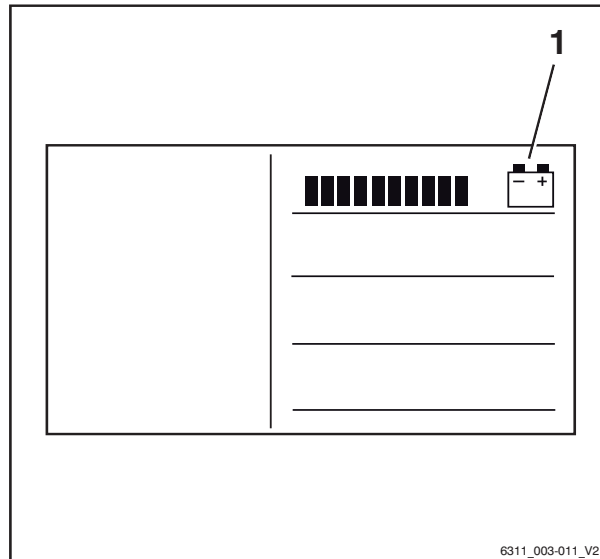

Reading from the battery indicator

The battery indicator is located on the side of the battery tray. Like the display-operating unit, the battery indicator shows the charge state of the lithium-ion battery. Warnings are issued only on this battery indicator.

- If you have any questions, contact your authorised service centre.

Charging state LEDs

When the battery is connected to the truck and the truck is switched on, the charge state LEDs (3) display the charge state in 10% increments. The charge state LEDs can light up green and red.

- A charge state of 0% to 20% is indicated by a red bar.
If this bar flashes, the charge state is < 2%.
The truck can no longer be moved.
- A charge state of > 20% to 30% is indicated by yellow bars.
- A charge state of > 30% to 100% is indicated by green bars.

When charging, the charge state LEDs (3) light up green as a chase light.

Service LED

The service LED (1) lights up red if the battery function is significantly restricted or if operation is not possible.

- Contact your authorised service centre.

Temperature LED

The temperature LED (2) indicates an increased temperature. Battery power is reduced. The LED remains illuminated until the temperature falls to within the normal range. The LED goes out as soon as the temperature falls into the normal range.

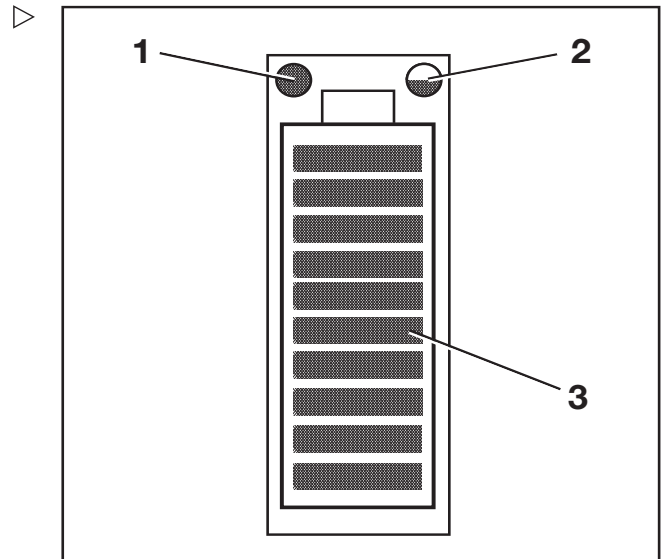

- | | |
|---|-------------------------------|
| 1 | Service LED (red) |
| 2 | Temperature LED (yellow/red) |
| 3 | Charge state LEDs (red/green) |



4

Operation

Handling the lithium-ion battery

Colour of LED	Cause	Consequence
Flash- ing yellow	Slightly increased temperature (> 60°C)	Power reduction
Solid yellow	Increased temperature (> 65°C)	Shut-off
Flash- ing red	Greatly increased temperature (> 70°C)	Shut-off
Solid red	Greatly increased temperature (> 75 °C)	Shut-off

Procedure if a lithium-ion battery has a low charge state

To prevent deep discharge of the lithium-ion battery, performance limitations are imposed once the charge state of the battery is $\leq 10\%$.

- If the charge state drops below 15%, drive to the charging station and charge the battery.

⚠ WARNING

There is no electric brake assistance when the battery is switched off!

The drives are de-energised when the battery is automatically switched off.

The truck will not be held on a slope by the electric brake.

- To brake, actuate the service brake.
-
- If the battery switches off, tow the truck to the charging station.
 - Charge the battery.

Charging the battery

⚠ CAUTION

Risk of component damage!

Incorrect connection or incorrect operation of the charging station or battery charger may result in damage to components!

- Follow the operating instructions for the charging station or battery charger and for the battery.

⚠ CAUTION

Risk of component damage!

Battery male connectors and battery charger connectors from different manufacturers are not compatible and may cause damage.

- Use battery male connectors and battery charger connectors produced by the same manufacturer.
- If the connectors are from different manufacturers, please contact your authorised service centre.

NOTE

To prevent deep discharge of the lithium-ion battery, performance limitations are imposed once the charge state of the battery drops to a certain level. The battery must be charged before the charge state drops below 15%.

To read the battery charge state; see the section entitled "Checking the battery charge status".

- Park the truck safely.
- Fully open any protective structures (e.g. fabric-covered cab).
- Open the battery cover fully.
- Disconnect the battery male connector by pulling the handle.
- Do not place any metal objects or tools on the battery.
- Keep away from naked flames and do not smoke.
- Check the battery cables for damage. If necessary, have the battery cables replaced by the authorised service centre.

Handling the lithium-ion battery

⚠ DANGER

There is a risk of damage, short circuiting and explosion!

- Do not place any metal objects or tools on the battery.
- Keep away from naked flames.
- Do not smoke.

-
- Connect the battery male connector to the plug on the battery charger.
 - Start the battery charger.

The charging process starts automatically. The display signals the charging process by illuminating the LEDs as a chase light.

The charger indicates when the battery is fully charged. Only disconnect the battery from the charger if there is no current is flowing.

The battery has no memory effect. Therefore, it can be charged in any charge state without the capacity of the battery being impaired.

At ambient temperatures below 0°C, the charging process will take much longer.

- Observe the information in the operating instructions for the battery and the battery charger.

After charging

The battery charger will stop automatically.

- Disconnect the battery male connector from the plug for the battery charger.
- Insert the battery male connector fully into the plug connection on the truck.



⚠ CAUTION

There is a risk of short circuit if the cables are damaged.

Do not crush the charging cable when closing the battery cover.

- Make sure that the charging cable does not come into contact with the battery cover.

- Close the battery cover. When doing so, ensure that no cables are crushed between the chassis and the battery cover.

The truck is equipped with a door contact switch for the battery cover. If the battery cover is not fully closed, the message **CLOSE THE DOOR** appears on the display of the display-operating unit. The truck will not move.

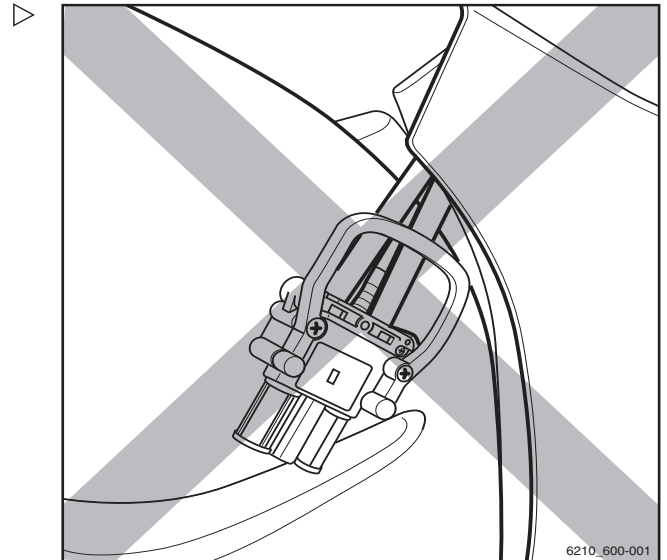

Replacing and transporting the battery

General information on replacing the battery

⚠ CAUTION

Risk of components being damaged by the lifting accessory and battery rolling away!

The lifting accessory and battery may roll away in an uncontrolled manner if the battery is not removed on a level, smooth floor with sufficient load-bearing capacity.

- Follow the operating instructions for the lifting accessories used.
- Always remove the battery on a level, smooth floor with sufficient load-bearing capacity.

The battery can be removed using the following lifting accessories:

- Truck
- Change frame (variant)
- Hydraulic drive

The load capacity of the lifting accessory used must at least match the battery weight (see battery identification plate).

4

Operation

Replacing and transporting the battery

Changing to a different battery type

The authorised service centre can convert the truck to a different battery type and capacity.

Note the following points:

- The new battery capacity and new battery type must be set in the display-operating unit.
If this is not done, the actual battery discharge status cannot be determined. The battery charge level is not displayed correctly.
In the worst case, the battery may be damaged by a deep discharge.
- When changing to TENSOR® batteries, the maximum speed of the truck must be limited to 17 km/h for technical reasons.
- Contact the authorised service centre in this situation.
- Only use lithium-ion batteries that have been approved by STILL with this truck.

Opening/closing the battery cover

Opening the battery cover

⚠ CAUTION

The outside mirror (1) is in the movement range of the battery cover. When opening the battery cover, a collision can cause components to be damaged.

- Fold outside mirror forwards.
- Ensure that there is sufficient lateral distance (at least 100 mm) from the battery cover.

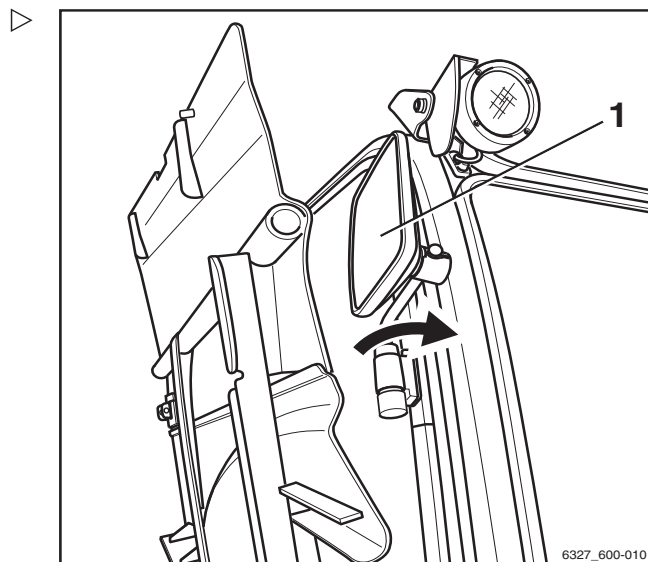

Operation

4

Replacing and transporting the battery

- Pull on the interlock (2) of the battery cover and lift battery cover at (A) grip position. ▷

The cover catch snaps into place.

Closing the battery cover

⚠ WARNING

When closing the battery cover, limbs could become trapped — risk of crushing!

When closing the battery cover, nothing should come between the battery cover and the edge of the chassis.

- Close the battery cover carefully.
- Only close the battery cover if there are no parts of the body in the way.

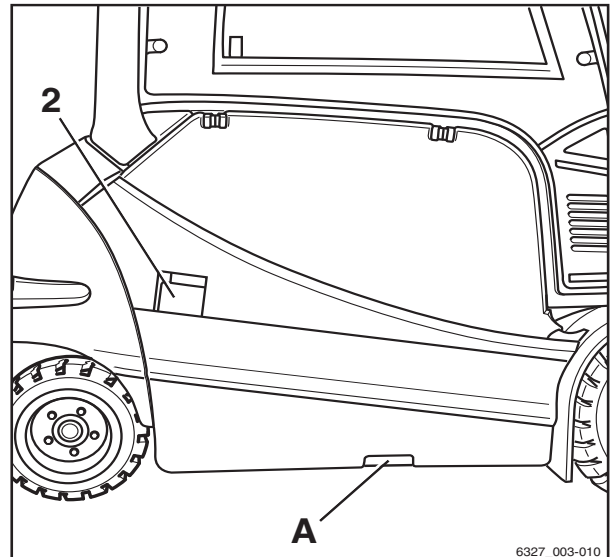

6327_003-010

⚠ WARNING

When closing the battery cover, there is a risk of trapping the battery cable. If the cable is crushed or sheared off, there is a risk of short circuit!

When closing the battery cover, nothing should come between the battery cover and the edge of the chassis.

- Close the battery cover carefully.
- Only close the battery cover if the battery cable is not in the way.

- Pull the cover catch (3) slightly out and pull the battery cover at the grip position downwards at the same time (B) until the cover catch is unlocked.

- Release the latch. ▷

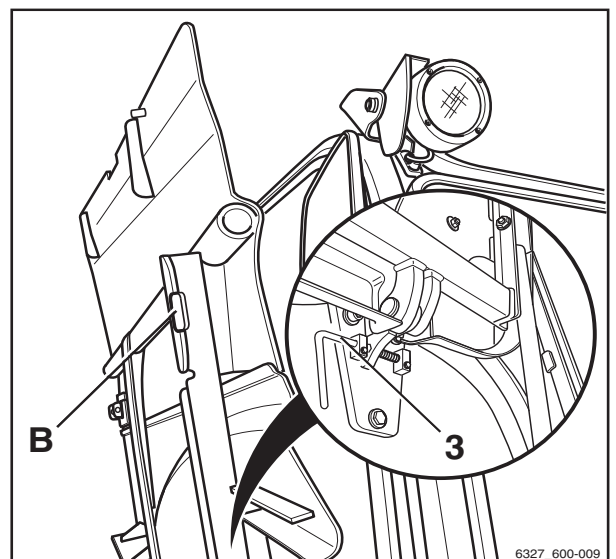

6327_600-009

4 Operation

Replacing and transporting the battery

- Before closing the battery cover, close the battery safety catches (5) until they lock into place.

⚠ DANGER

If the battery is not locked correctly, the battery can slide out of the truck, with potentially fatal consequences!

- Ensure that the battery safety catch (5) is locked as far as it will go.

i NOTE

If the battery safety catch (5) is difficult to move, use the coupling pin (4) to help.

- Allow the battery cover lock to snap into place.

The battery cover interlock must snap into place properly or the built-in sensor (6) will generate the error message CLOSE THE DOOR on the display and the truck will not drive.

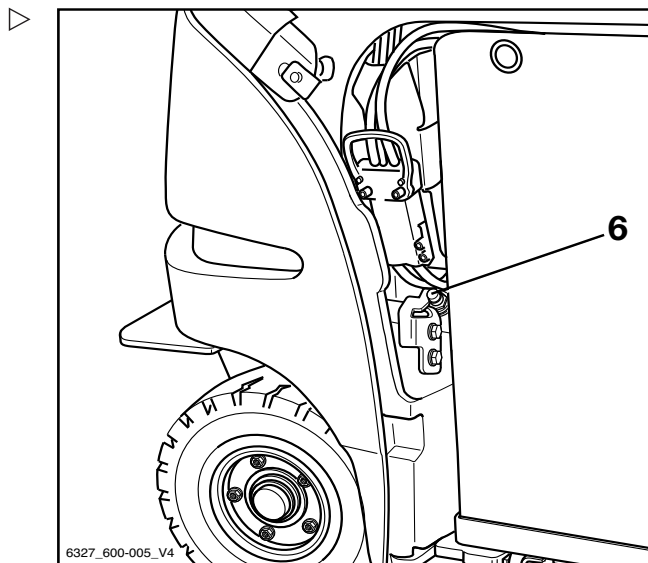
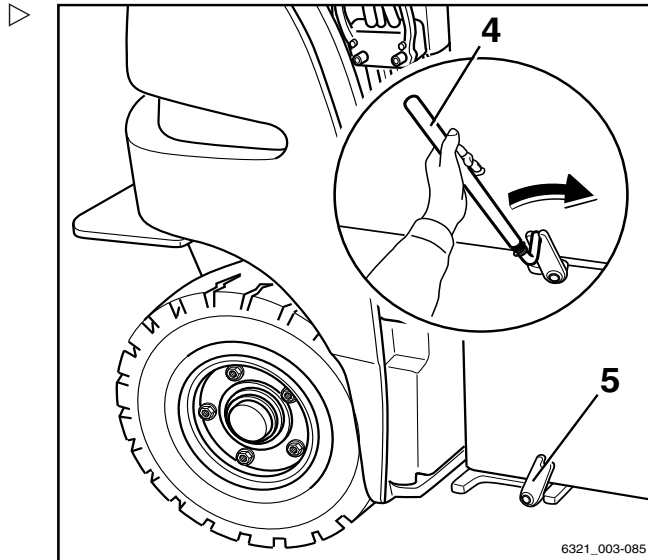

Replacing and transporting the battery

i NOTE

The apertures in the flap (arrowed) are necessary for forced ventilation and must not be blocked.

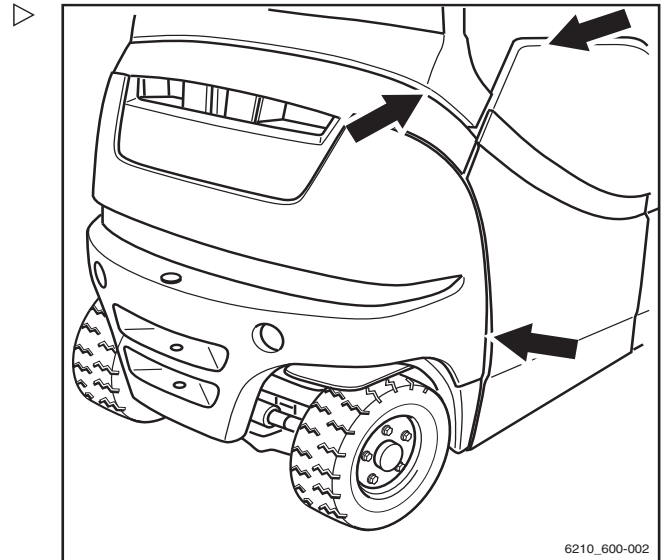

Special notes for installing the lithium-ion battery

With the exception of the following special notes, lithium-ion batteries are replaced in the same way as lead-acid batteries.

- Push down the lifting eyes before inserting the battery into the battery compartment. Make sure that the lifting eyes **do not** protrude.

The lifting eyes may bend in the event of a collision with the truck chassis.

- Install the lithium-ion battery with the display facing the outside of the truck so that it can be read when the battery door or battery cover is open.
- Lay the battery cable on the battery. Make sure that the cable does not come into contact with the truck chassis during installation.

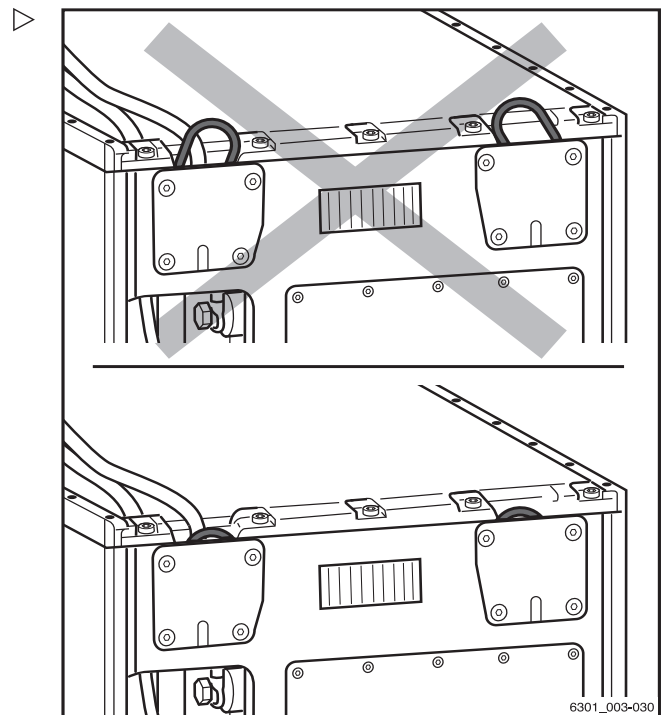



Replacing and transporting the battery

Replacing the battery using forklift truck or pallet truck

⚠ CAUTION

Risk of damage!

The battery must only be removed on a level and smooth floor in accordance with the operating instructions of the truck or lift truck used.

Preparation

- Park the truck safely.
- Open the battery cover.

⚠ CAUTION

Risk of component damage!

If you remove the battery male connector when the key switch is switched on (under load), an arc will be produced. This can lead to erosion at the contacts, which considerably shortens their service life.

- Switch off the key switch before the battery male connector is disconnected.
- Only disconnect the battery male connector with the key switch switched on in an emergency.

Operation

4

Replacing and transporting the battery

- Disconnect the battery male connector (1).



CAUTION

There is a risk of short circuit if the cables are damaged!

Position the battery cable on the battery in such a way that it cannot be crushed when removing or inserting the battery or when closing the battery cover.

- Check the connecting cables for damage.
- Ensure that the battery cable does not come into contact with the battery cover.

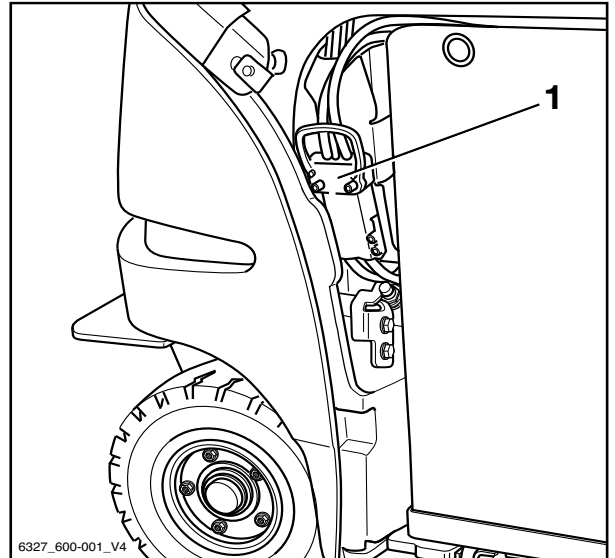

WARNING

Risk of crushing and shearing!

Personnel must not stand directly next to the battery or between the battery and the forklift truck when removing and inserting the battery with the forklift truck or lift truck.

WARNING

Risk of accident!

The load capacity of the truck in use must at least match the battery weight (see battery identification plate).

- Before picking up the battery, the fork arms must be adjusted to match the opening in the chassis (A). Push the fork arms together. Maintain the maximum possible distance between the fork arms.

Taking up the battery

CAUTION

Risk of component damage!

- The fork arms must not be moved underneath the battery beyond the length of the opening in the chassis.

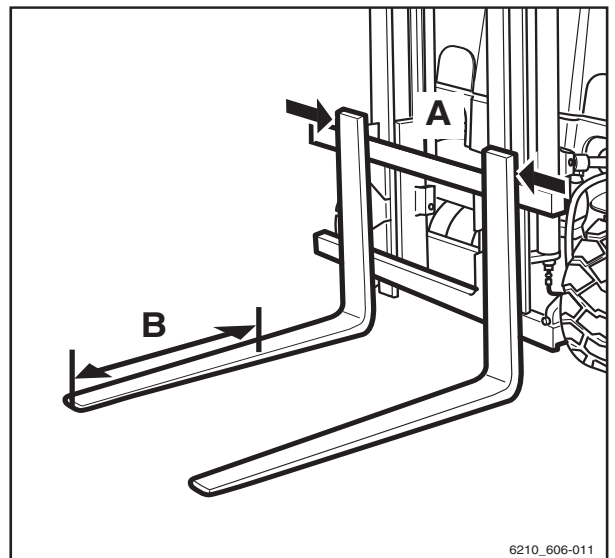

NOTE

It is helpful if this measurement (B), measured from the fork tips, is marked on the fork arms.

4 Operation

Replacing and transporting the battery

- Fold the battery safety catches (2) to the side.
- Move the fork arms carefully underneath the battery.
- Carefully lift the battery up and out of the truck. Pay attention to the distance to the chassis.

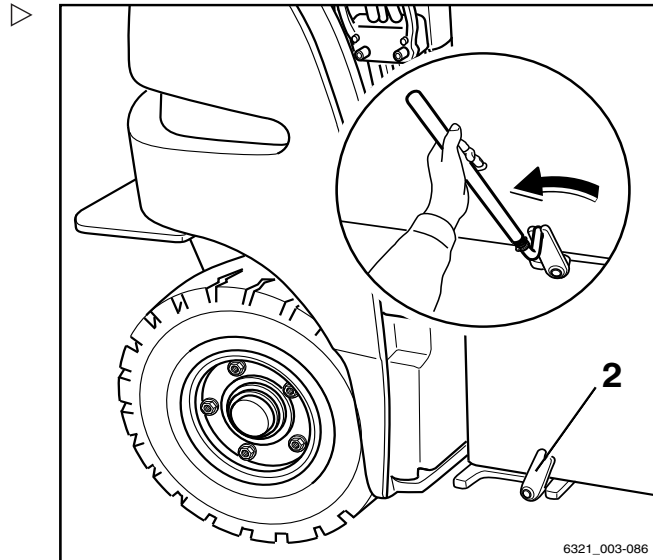

⚠ WARNING

Risk of crushing and shearing!
The battery must be transported very carefully, i.e. at a low speed, using slow steering movements and careful braking.

- Do not use the methods described above to transport the battery over long distances.
- Carefully remove the battery from the truck.
- Set the battery down on a stable base so that it is secure. Position the battery against the stops on the base.
- Pick up the new battery and transport it to the truck.
- Position the battery cable on the battery so that it will not become trapped when the battery is inserted.
- Position the battery at a right angle to the truck.
- Carefully insert the battery into the battery compartment.

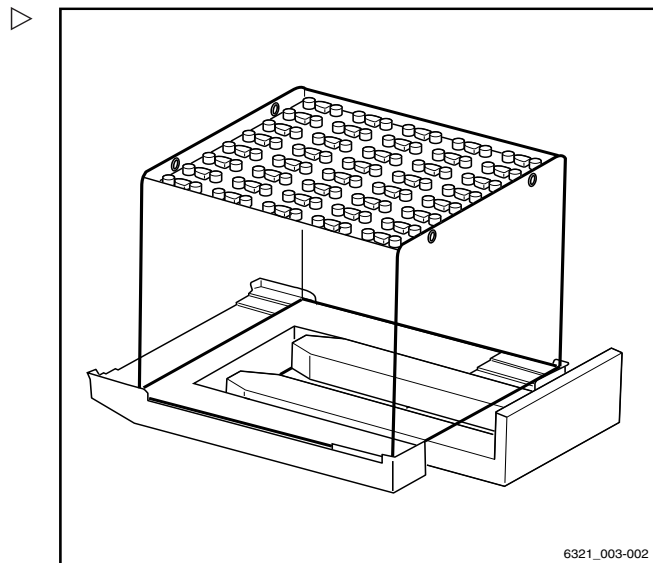

Once the battery is positioned correctly in the battery compartment:

- Carefully lower the battery.
- Carefully move the lifting accessory out from under the battery.
- Close the battery safety catches until they lock into place.

Operation

4

Replacing and transporting the battery

- Insert the battery male connector (1).



⚠ CAUTION

There is a risk of short circuit if the cables are damaged!

Do not crush the battery cable when closing the battery cover.

- Ensure that the battery cable does not come into contact with the battery cover.

- Close the battery cover.

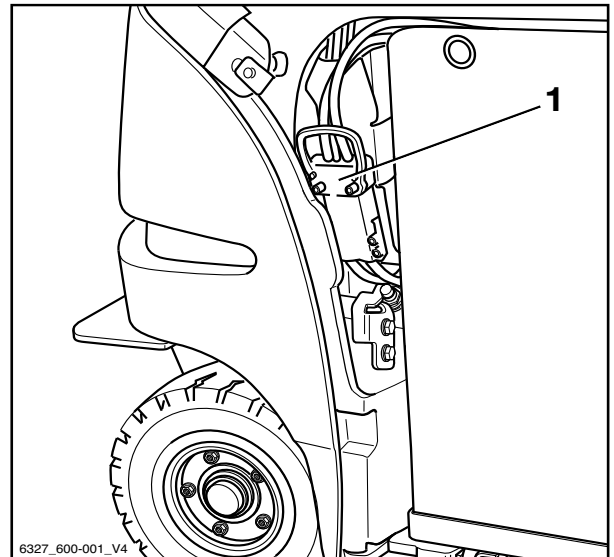

Replacing the battery using a change frame (variant)

⚠ CAUTION

Risk of damage!

Place the battery change frame along with the traction battery only onto a firm surface with sufficient load-bearing capacity.

Do not place the battery change frame with the traction battery onto a soft surface or in a rack.

The battery change frame (variant) features an advantageous design that allows a truck or pallet stacker to pick up the battery quickly. The battery along with the change frame can be set down and charged. The change frame fits between the battery holding fixtures in the battery compartment of the truck. Once the battery has been set down onto its holding fixtures, the change frame is moved back out of the truck.

Preparation

- Park the truck securely.
- Open the battery cover.

4 Operation

Replacing and transporting the battery

⚠ CAUTION

Risk of component damage!

If you disconnect the battery male connector while the key switch is switched on (under load), an arc will be produced. This can lead to erosion at the contacts, which considerably shortens their service life.

- Switch off the key switch before the battery male connector is disconnected.
- Do not disconnect the battery male connector while the key switch is switched on, except in an emergency.

- Disconnect the battery male connector (1).

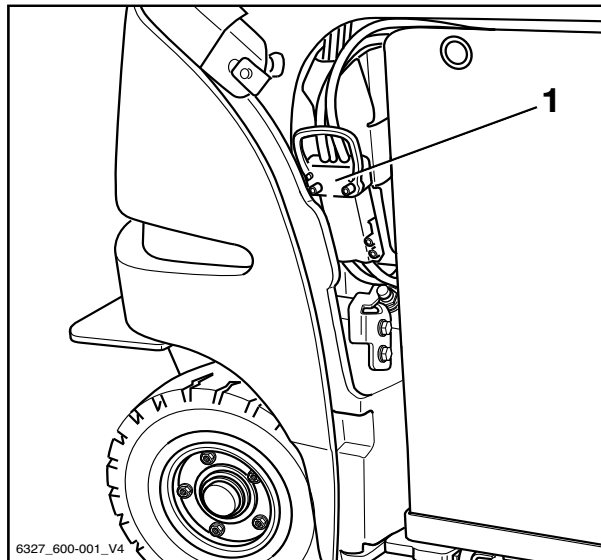

6327_600-001_V4



⚠ CAUTION

There is a risk of a short circuit occurring if the cables are damaged!

Position the battery cable on the battery in such a way that it cannot be crushed when removing or inserting the battery or when closing the battery cover.

- Check the connection cable for damage.
- Ensure that the battery cable does not come into contact with the battery cover.



⚠ WARNING

Risk of crushing/shearing!

Personnel must not stand directly next to the battery or between the battery and the truck when removing and inserting the battery with the truck or lift truck.

⚠ WARNING

Risk of accident!

The load capacity of the truck/lift truck in use must at least match the battery weight (see battery identification plate).

- Ensure that the maximum load capacity of the change frame is not exceeded.

The maximum load capacity of the change frame is specified on the identification plate.

- Before picking up the change frame, adjust the fork arm distance.

Operation

4

Replacing and transporting the battery

- Position the change frame (3) under the battery (2) so that the centre of the battery (1) is in line with the recess (4) in the change frame.

This alignment ensures that the battery is positioned centrally on the change frame. The battery must be positioned centrally on the change frame in order for the change frame to be moved into the truck and to reduce the risk of the battery tipping over when being moved. If multiple batteries are used, it is advisable to permanently mark the centre of the battery (1) (e.g. using a strip of adhesive tape).

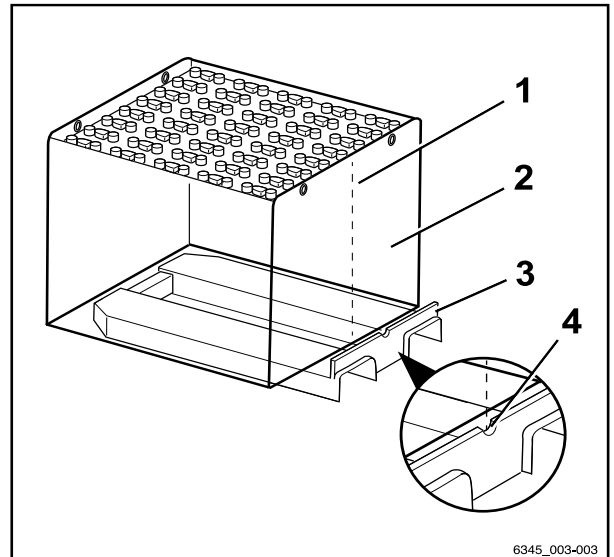

6345_003-003

Picking up the battery

⚠ CAUTION

Risk of component damage!

- Move the change frame under the battery only up to the edge of the stop.

- Fold the battery safety catches (2) to the side.
- Carefully move the change frame under the battery.
- Carefully lift the battery up and out of the truck. Pay attention to the distance to the chassis.

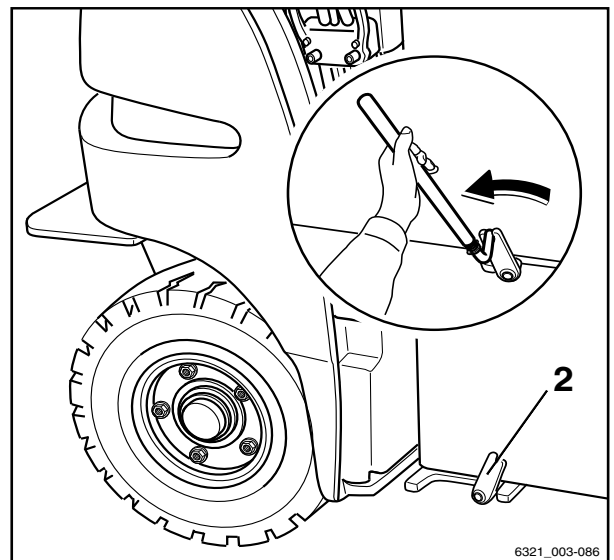

6321_003-086

⚠ WARNING

Risk of crushing/shearing!

The battery must be transported very carefully, i.e. at a low speed, using slow steering movements and careful braking.

- Do not use the methods described above to transport the battery over long distances.
- Carefully remove the battery from the truck.

4 Operation

Replacing and transporting the battery

The battery (1) can remain on the change frame (2). The change frame can then be used to set the battery down.

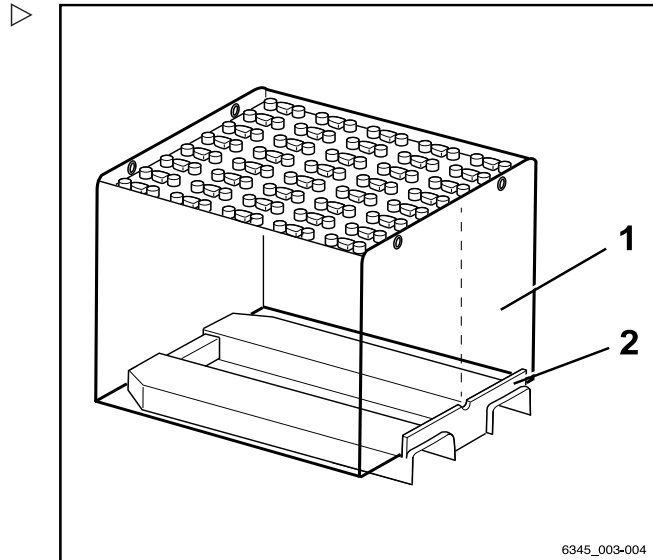

- If a substructure (3) is used to set down the battery (1), ensure that the change frame (2) does not protrude beyond the battery.
- Set the battery down on a stable base so that it is secure. Position the battery against the stops on the base.
- Move the change frame out from under the battery.
- Pick up the new battery using the change frame and transport the new battery to the truck.
- Position the battery cable on the battery so that it will not become trapped when the battery is inserted.
- Position the battery at a right angle to the truck.
- Carefully insert the battery into the battery compartment.

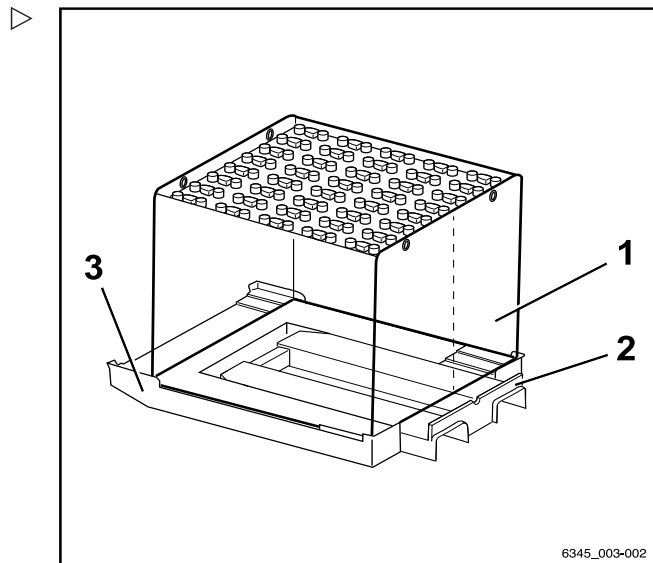

Once the battery is positioned correctly in the battery compartment:

- Carefully place the battery onto the battery holding fixtures.
- Carefully move the change frame out from under the battery.

Operation

4

Replacing and transporting the battery

- Close the battery safety catches (2) until they latch into place.
- Plug in the battery male connector (1)



⚠ CAUTION

There is a risk of a short circuit occurring if the cables are damaged!
Do not crush the battery cable when closing the battery cover.

- Ensure that the battery cable does not come into contact with the battery cover.

- Close the battery cover.

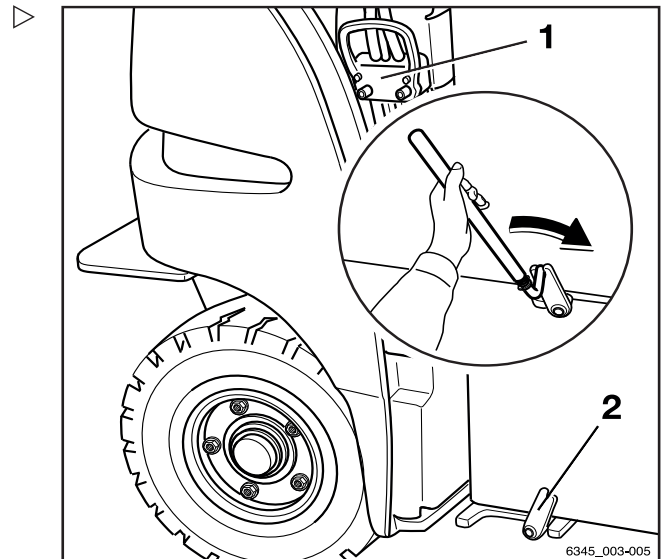

Replacing the battery with the hydraulic battery carrier

Preconditions

The following prerequisites apply when replacing a battery with the hydraulic battery carrier:

- The extension area must be free of obstacles
- The ground must be clean, even and offer sufficient load capacity

i NOTE

If a battery is deeply discharged, it is not possible to use the battery carrier.

4 Operation

Replacing and transporting the battery

Emergency off when moving the battery ▷

When working with the hydraulic battery carrier, it may not be possible to reach the emergency off switch. In an emergency, disconnect the battery male connector (1).

⚠ CAUTION

Potential for damage to the battery male connector! If the battery male connector is connected while the key switch is on (under load), a jump spark will be produced. This jump spark can damage the contacts and considerably shorten the service life of the contacts.

- Do not connect the battery male connector with the key switch switched on.
- Make sure that the key switch is switched off before connecting the battery male connector.

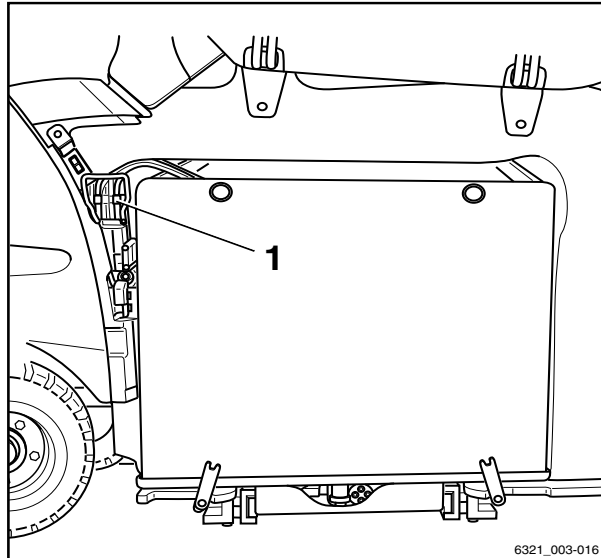

Extending the battery hydraulically ▷

- Apply the parking brake.

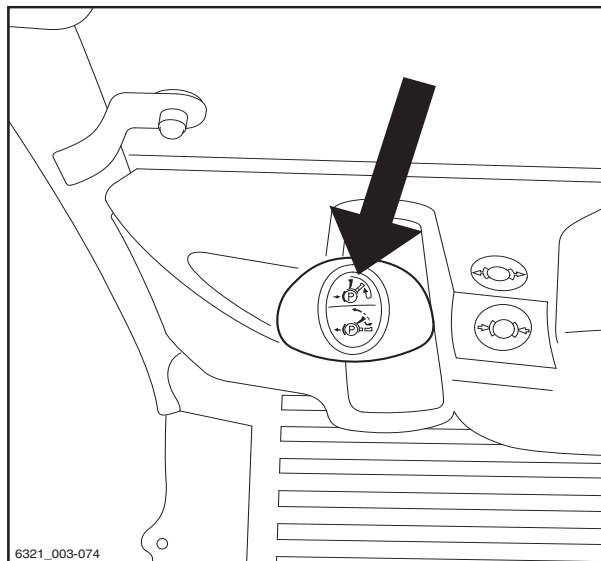

Operation

4

Replacing and transporting the battery

- Make sure that there is no load on the driver's seat.
- Open the battery cover fully.

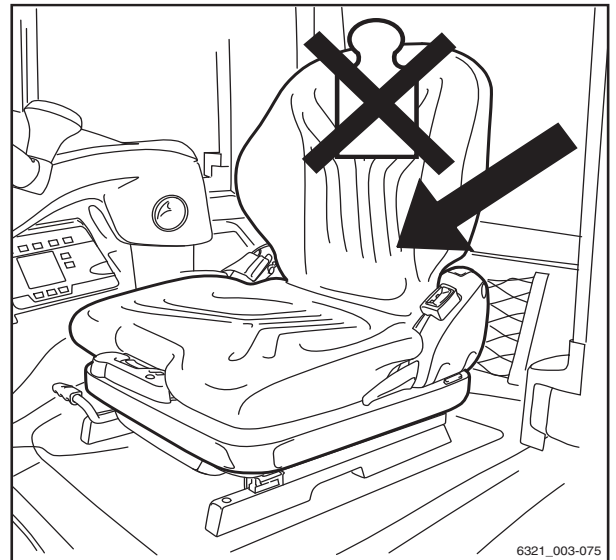

6321_003-075

- Fold down the battery safety catches.

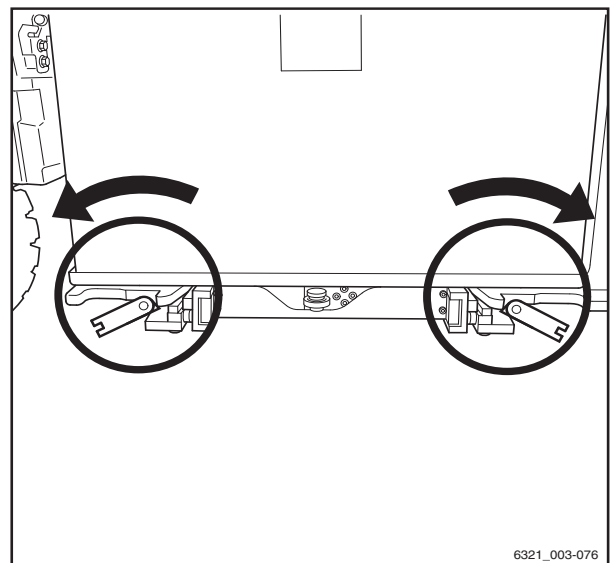

6321_003-076

⚠ WARNING

Risk of crushing/shearing!

When extending the battery carrier, there must be no personnel in the extension area. There is a risk of crushing and shearing when the battery carrier extends.

The battery male connector must remain in reach as an emergency off mechanism.

- Place the counterweight and outside the extension area.

4

Operation

Replacing and transporting the battery

- Press the extension button until the carriage ▷ has reached its end position.

During the extension procedure, the support also extends automatically.

⚠ CAUTION

Risk of component damage!

When extending the carriage, the battery cable may collide with components and become damaged.

- Ensure that the battery cable does not become stuck or crushed.
- In the event of a malfunction, release the extension button and correct the malfunction.

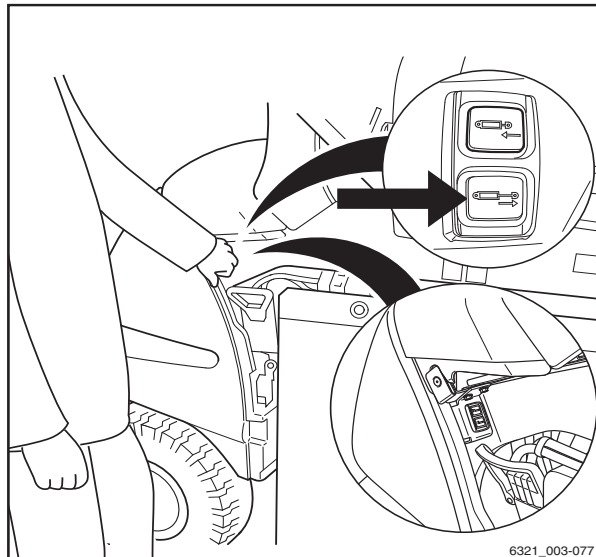

- Ensure that the battery cable is not damaged when the carriage is extended. ▷

i NOTE

If the movement of the carriage is restricted by obstacles, release the push button. The carriage can only be retracted. If the push button is actuated continuously, the drive switches off after 50 seconds.

⚠ WARNING

Risk of crushing!

Never reach under the battery to remove obstacles.

- Retract the battery again and remove the obstacle.

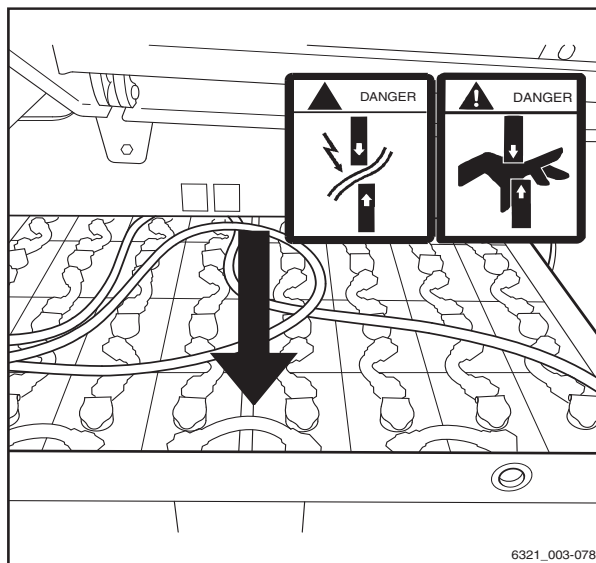

i NOTE

If the motor protection function is triggered: the motor protection function is controlled by a counter. After retracting and extending five times, the hydraulic battery carrier is disabled for 60 minutes. The counter is reset when the motor has been running for less than five minutes and there is no actuation for 15 minutes.

Operation

4

Replacing and transporting the battery

After extending the battery fully

- To prevent short circuits, place a rubber mat on the battery if it has open terminals or connectors.

⚠ CAUTION

Potential for damage to the battery male connector!
If the battery male connector is disconnected while the key switch is on (under load), an arc will be produced. This can lead to erosion at the contacts, which considerably shortens the service life of the contacts.

- Switch off the key switch before disconnecting the battery male connector.
- Do not disconnect the battery male connector while the key switch is switched on, except in an emergency.

- Switch off the key switch.
- Disconnect the battery male connector and place it on the battery.
- Hook the battery on to suitable lifting gear. Observe the operating instructions for the lifting gear.
- Lift the battery sideways out of the truck. Ensure that there is sufficient distance from the battery cover.

⚠ CAUTION

Risk of component damage!

- Do not allow slack lifting gear to fall onto the battery cells.



⚠ DANGER

Risk of death from suspended loads!

- Never walk or stand underneath suspended loads.

- Lift the battery out of the battery tray and set it down carefully.
- To prevent damage to the truck when the crane is used, ensure that the battery is set down at a sufficient distance from the truck.
- Before inserting the battery, check that the battery tray is free of objects.

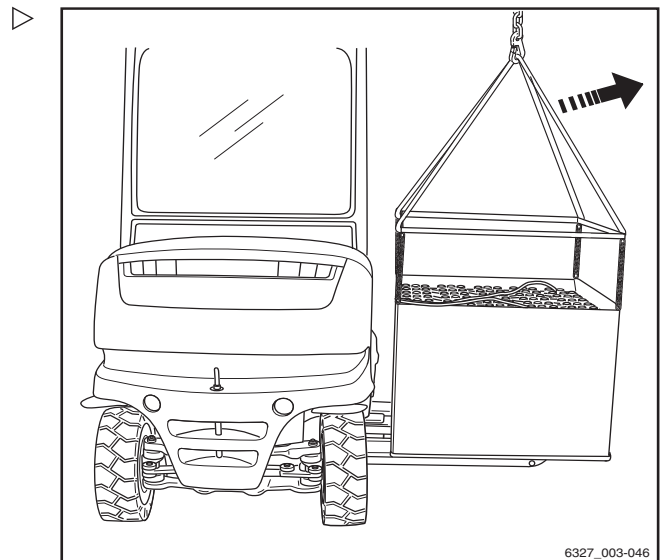
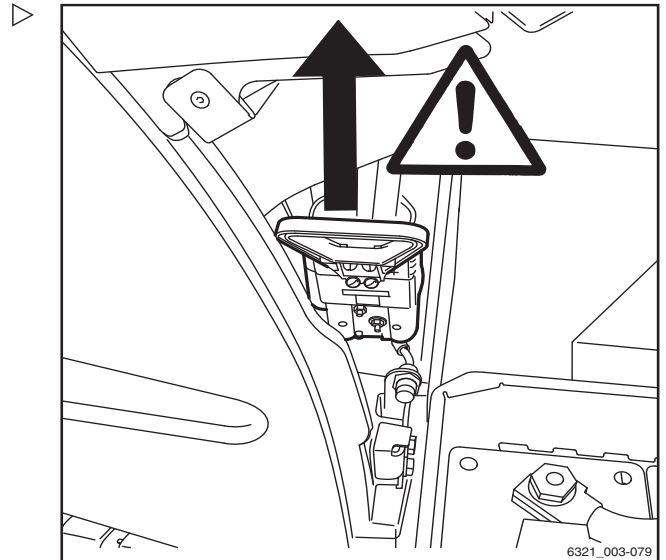

4

Operation

Replacing and transporting the battery

- Carefully insert the replacement battery into the battery tray.

After inserting the battery into the battery tray ▷

⚠ CAUTION

Potential for damage to the battery male connector!

If the battery male connector is connected while the key switch is on (under load), a jump spark will be produced. This jump spark can damage the contacts and considerably shorten the service life of the contacts.

- Do not connect the battery male connector with the key switch switched on.
 - Make sure that the key switch is switched off before connecting the battery male connector.
-
- Ensure that the battery male connector and the plug connection are dry, clean and free of foreign objects.
 - Connect the battery male connector.
 - Switch on the key switch.

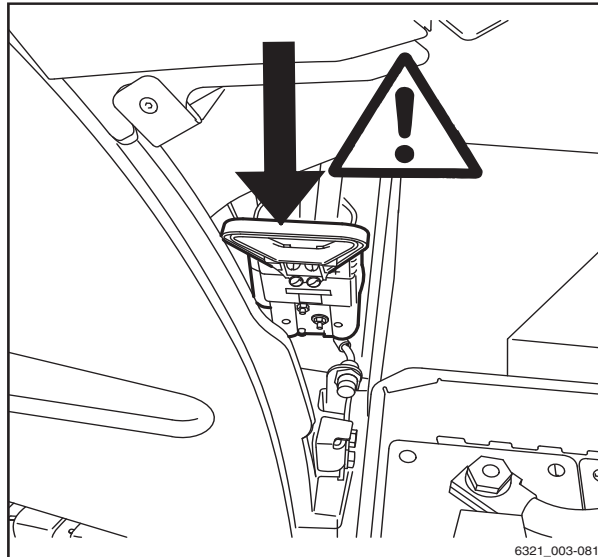

⚠ WARNING

Risk of injury!

- Personnel must stand beside the counterweight and outside the retraction area.

⚠ CAUTION

Risk of component damage!

When retracting the carriage, the battery cable may collide with components and become damaged.

- Ensure that the battery cable does not become stuck or crushed.
- In the event of a malfunction, release the retraction button and correct the malfunction.

Operation

4

Replacing and transporting the battery

- Make sure that the battery cable is not damaged when the carriage is retracted.

⚠ WARNING

Risk of crushing!

Do not reach into the battery compartment if the battery carrier is being operated.

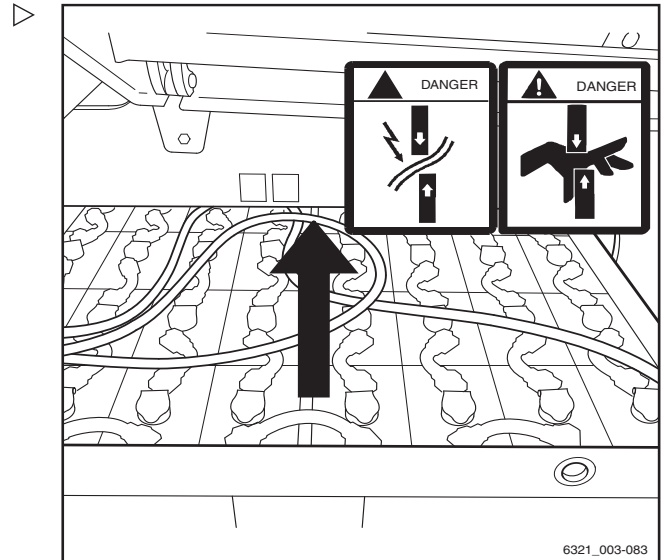

- Press the retraction button until the carriage has reached its end position.
- Release the push button.

i NOTE

If the movement of the carriage is restricted by obstacles, release the push button.

⚠ WARNING

Risk of crushing!

Never reach under the battery to remove obstacles.

- Extend the carriage again.
- Lift the battery again using the crane, swivel the battery to the side and remove the obstacle.

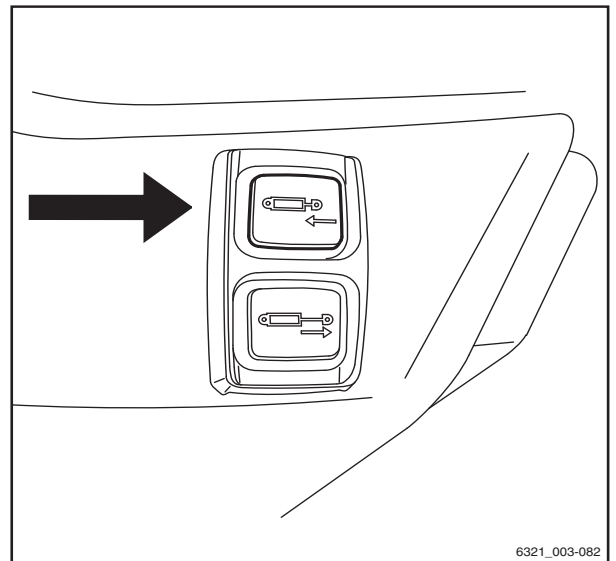

⚠ CAUTION

Risk of damage!

If the drive system overheats, the battery carrier is switched off automatically. After a cooling-down period of about 60 minutes, the battery carrier can be reactivated.

- Notify the authorised service centre if the battery carrier is blocked.

4 **Operation**

Replacing and transporting the battery

- Close the battery safety catches.
- Close the battery cover.

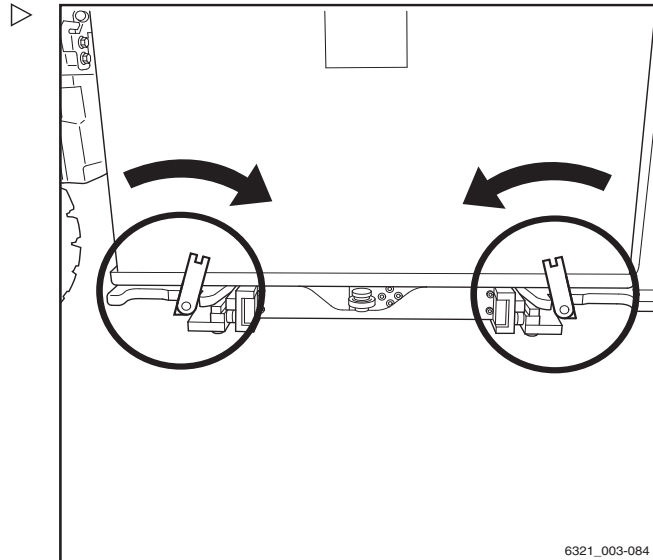

Messages and errors when using the hydraulic battery carrier

Error code	Cause	Remedy
5920	The unit has overheated.	Allow the truck to cool down for one hour.
5910		Notify the authorised service centre.
5930		
5931		

Message	Cause	Remedy
BATTERY CHANGER	The battery support is not fully retracted.	Press the "Retract battery" push button until the support is fully retracted. If this operation is not successful, notify the authorised service centre.
CLOSE THE DOOR	The battery cover is not closed correctly.	Close the battery cover.

Transporting the lead-acid battery by crane ▷



⚠ DANGER

There is risk of fatal injury from being struck by falling loads!

- Never walk or stand underneath suspended loads.

The tray for the lead-acid battery (1) is equipped with four lifting eyes. The battery may only be transported by crane using a lifting gear and bridge piece (2) that are suitable in terms in size and load capacity.

- To avoid short circuits, cover batteries with open terminals or connectors with a rubber mat.
- Observe the operating instructions for the lifting gear.
- Attach the battery (1) to suitable lifting gear (2).
- Lift the battery carefully and ensure that it hangs straight on the lifting gear.

The lifting gear must be vertical when lifting, so that no lateral pressure is applied to the tray.

- Set the battery down carefully.
- Remove the lifting gear after the battery has been set down.
- Do not place slack lifting gear on the battery cells or allow it to fall on the battery cells.

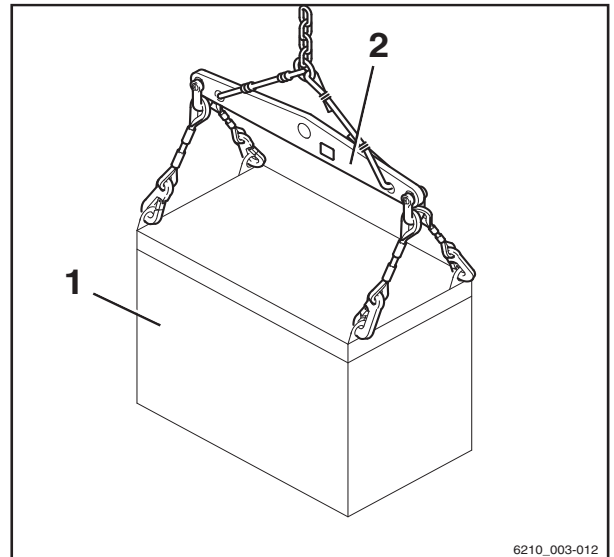

6210_003-012

4 Operation

Replacing and transporting the battery

Transporting the lithium-ion battery by crane



DANGER

There is risk of fatal injury from being struck by falling loads!

- Never walk or stand underneath suspended loads.

WARNING

Risk of accident due to weakened lifting eyes.

If bent lifting eyes are straightened, they lose their rigidity. The lifting eyes are then no longer able to support the weight of the battery. The battery may fall.

- Do not straighten bent lifting eyes.
- Have bent lifting eyes replaced by the authorised service centre.

The lithium-ion battery (1) is equipped with four extendable lifting eyes. The battery may only be transported by crane using a lifting gear and bridge piece (2) that are suitable in terms in size and load capacity.

- Pull out the two lifting eyes (1) on each side and tilt them towards each other.

The lifting eyes are locked in this position.

- Observe the operating instructions for the lifting gear.
- Attach the lifting gear to the four lifting eyes.
- Lift the battery carefully and ensure that it hangs straight on the lifting gear.

The lifting gear must be vertical when lifting, so that no lateral pressure is applied to the tray.

- Set the battery down carefully.
- Remove the lifting gear after the battery has been set down. Lift up and release the lifting eyes to lower them.

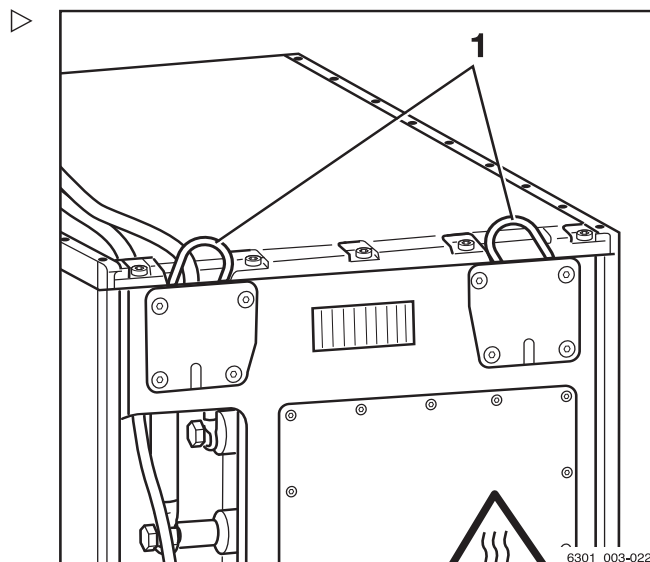
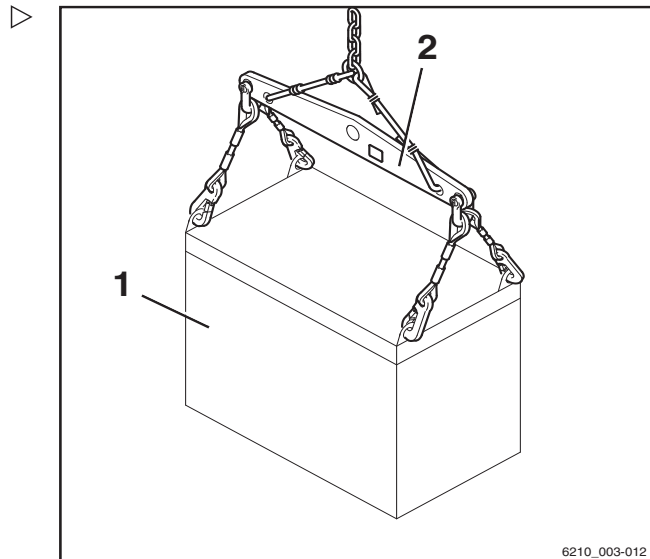

Cleaning the truck

Cleaning the truck



⚠ WARNING

Risk of injury from falling off the truck!

When climbing onto the truck, there is a risk of getting stuck or slipping and falling. Use suitable equipment to reach higher points on the truck.

- Use only the steps provided to climb onto the truck.
- Use equipment such as stepladders or platforms to reach inaccessible areas.



⚠ WARNING

Risk of fire due to flammable cleaning materials!

Flammable cleaning materials can be ignited by hot components.

- Do not use any flammable cleaning materials.



⚠ CAUTION

Risk of fire due to flammable materials!

Deposits and solids can be ignited by hot components, e.g. drive units.

- Remove deposits and solids.

⚠ CAUTION

Risk of damage to the battery male connector when disconnecting!

If the battery male connector is disconnected while the key switch is switched on under load, an arc will be produced. The arc can damage the contacts and considerably shorten the service life of the contacts.

- Switch off the key switch.
- Only disconnect the battery male connector while the key switch is switched off.

⚠ CAUTION

If water penetrates the electrical system, there is a risk of short circuit!

- Adhere strictly to the following steps.

Cleaning the truck

⚠ CAUTION

Excessive water pressure or water and steam that are too hot can damage truck components.

- Adhere strictly to the following steps.

⚠ CAUTION

Abrasive cleaning materials can damage the surfaces of components!

Using abrasive cleaning materials that are unsuitable for plastics can cause plastic parts to dissolve or become brittle. The screen on the display-operating unit could become cloudy.

- Adhere strictly to the following steps.
- Park the truck safely.
- Switch off the key switch.
- Disconnect the battery male connector.
- Do not spray electric motors and other electrical components or their covers directly with water.
- Use only high-pressure cleaners with a maximum output power of up to 50 bar and 85°C.
- If a high-pressure cleaner is used, maintain a distance of at least 20 cm between the nozzle and the object being cleaned.
- Do not aim the cleaning jet directly at adhesive labels or decal information.
- Remove all deposits and accumulations of foreign materials in the vicinity of hot components.
- Use only non-flammable fluids for cleaning.
- Note the manufacturer's guidelines for working with cleaning materials.
- Clean plastics only with cleaning materials intended for plastics.
- Note the manufacturer's guidelines for working with cleaning materials.
- Clean the truck exterior using water-soluble cleaning materials and water. Cleaning with a water jet, a sponge or a cloth is recommended.
- Clean all accessible areas.

- Before lubrication, clean the oil filling openings and the area around the oil filling openings, as well as the lubricating nipples.

Cleaning the electrical system

⚠ WARNING

Danger of electric shocks due to residual capacity!

- Never reach into the electrical system with your bare hands.



⚠ CAUTION

Cleaning electrical system parts with water can damage the electrical system.

Cleaning electrical system parts with water is forbidden!

- Do not remove covers etc.
- Use only dry cleaning materials in accordance with the manufacturer's specifications.

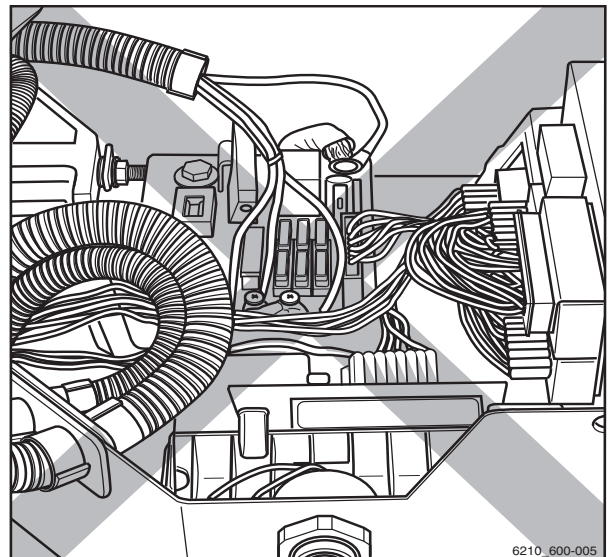

6210_600-005

- Clean the electrical system parts with a metal-free brush and blow the dust off with low-pressure compressed air.

Clean load chains

⚠ WARNING

Risk of accident!

Load chains are safety elements.

The use of cold cleaning solvents, chemical cleaners or fluids that are corrosive or contain acid or chlorine can damage the chains; use of these items is forbidden!

- Observe the manufacturer's guidelines for working with cleaning materials.
- Place a collection vessel under the lift mast.
- Clean with paraffin derivatives, such as benzene.
- When using a steam jet, do not use additional cleaning agents.

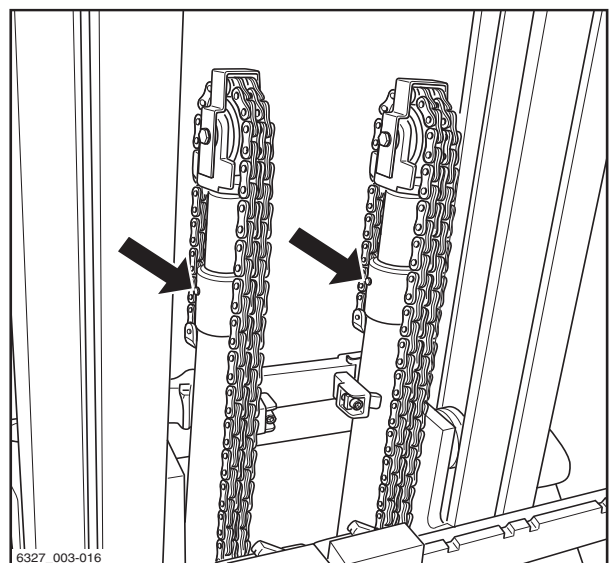

6327_003-016

4 Operation

Cleaning the truck

- Remove any water in the chain links using compressed air immediately after cleaning. Move the chain several times during this procedure.
- Immediately after drying the chain, spray it with chain spray. Move the chain several times during this procedure.

ENVIRONMENT NOTE

Dispose of any fluid that has been spilled or collected in the collection vessel in an environmentally friendly manner.

- Observe the national regulations for the country of use.

Cleaning the windows

Any panes of glass, e.g. cab windows (variant), must always be kept clean and free of ice. This is the only means of guaranteeing good visibility.

CAUTION

Do not damage the rear window heater (inside).
 - Take great care when cleaning the rear window (1) and do not use any objects with sharp edges.

- Clean the windows.

NOTE

Cleaning can be done using a commercially available glass cleaner.

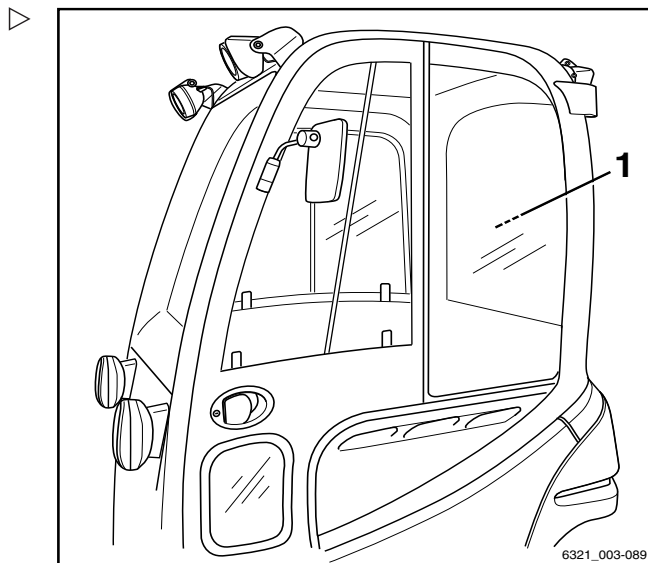

After cleaning

CAUTION

Danger of short-circuits!
 Ingress of moisture into the battery male connector can lead to an electrical short circuit.

- Use compressed air to dry the battery male connector before you connect the battery male connector.
- Only connect the battery male connector if it is dry.



- Thoroughly dry the truck after wet cleaning, e.g. using compressed air.
- Apply a thin layer of oil or grease to all uncoated moving parts.
- Grease the truck.
- Lubricate the joints and controls.
- Lubricate the battery cover interlock.
- Check that the battery male connector is dry before you connect the battery male connector.

 **NOTE**

The more often the truck is cleaned, the more frequently the truck must be lubricated.

4 Operation

Transporting the truck

Transporting the truck

Transport

⚠ CAUTION

Danger of material damage from overloading!

If the truck is driven onto a means of transport, the load capacity of the means of transport, the ramps and loading bridges must be greater than the actual total weight of the truck. Components may become permanently deformed or damaged due to overloading.

- Determine the actual total weight of the truck.
- Only load the truck if the load capacity of the means of transport, the ramps and loading bridges is greater than the actual total weight of the truck.

Determining the actual total weight

- Park the truck securely.
- Determine the unit weights by reading the truck nameplate and, if necessary, the attachment (variant) nameplate.
- Add the determined unit weights to obtain the actual total weight of the truck:

Tare weight (1)

+ Max. permissible battery weight (2)

+ Ballast weight (variant) (3)

+ Attachment net weight (variant)

+ 100 kg allowance for driver

= Actual total weight

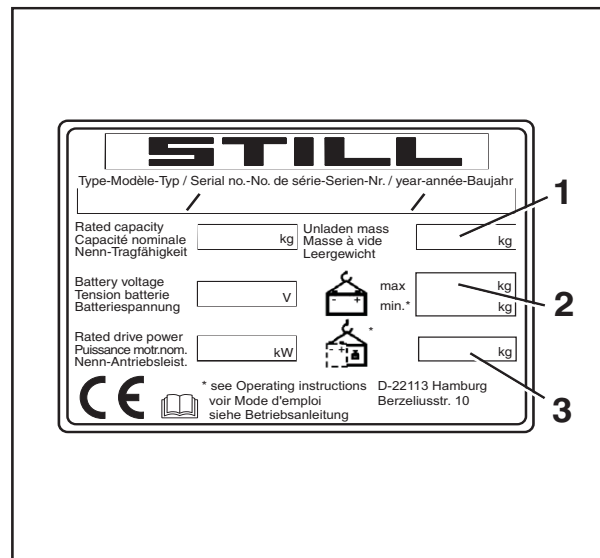

⚠ DANGER

Risk of accident from the truck crashing!

Steering movements can cause the tail end to veer off the loading bridge towards the edge. This may cause the truck to crash.

- Before driving over a loading bridge, ensure that it is installed and secured properly.
- Ensure that the transport vehicle to be driven onto has been sufficiently secured against moving.
- Maintain a safety distance from edges, loading bridges, ramps, working platforms etc.
- Drive slowly and carefully onto the transport vehicle.

Setting chocks

- Secure the truck from rolling away by placing a wheel chock in front of each front wheel and behind each back wheel (1).
- Park the truck securely.

⚠ CAUTION

Risk of component damage!

If you remove the battery male connector when the key switch is switched on (under load), an arc will be produced. This can lead to erosion at the contacts, which considerably shortens their service life.

- Switch off the key switch before the battery male connector is disconnected.
- Only disconnect the battery male connector with the key switch switched on in an emergency.

- Ensure that the key switch is switched off.
- Disconnect the battery male connector.

i NOTE

If the electric parking brake (variant) cannot be triggered electrically, it must be applied manually; see the chapter entitled "Emergency operation of the electric parking brake".

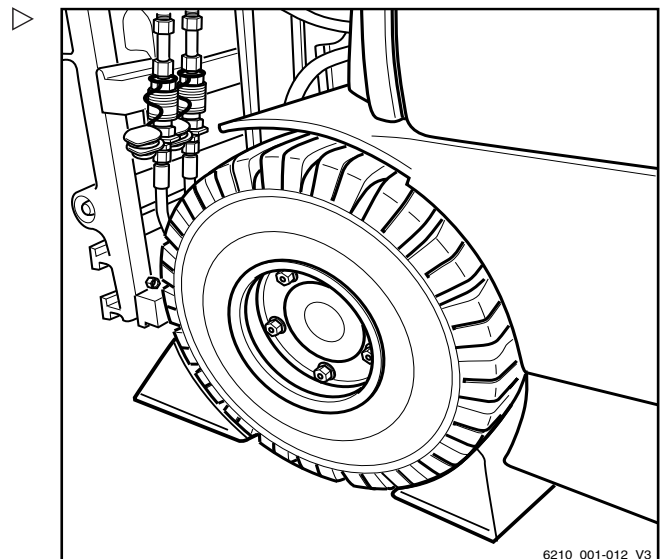

4 Operation

Transporting the truck

Lashing

CAUTION

Abrasive lashing straps can rub against the surface of the truck and cause damage.

- Position slip-resistant pads beneath the lifting points (e.g. rubber mats or foam).

- Attach lashing straps (1) to both sides of the truck and lash the truck to the rear. ▷

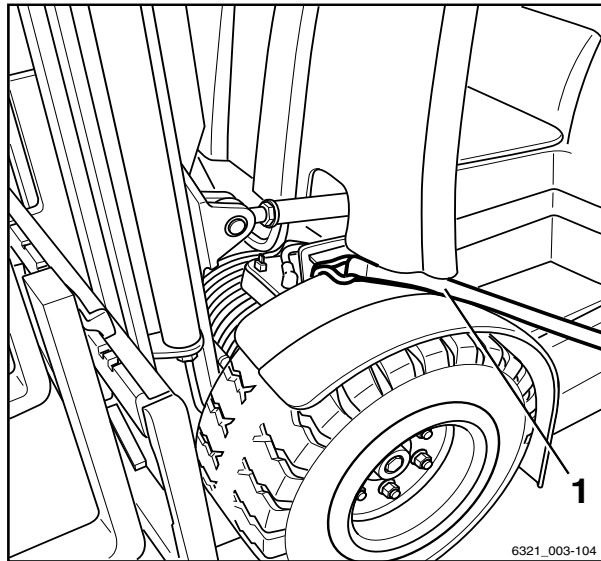

- Attach lashing straps (1) to the coupling pin (2) or loop around the coupling pin and lash the truck to the side. ▷

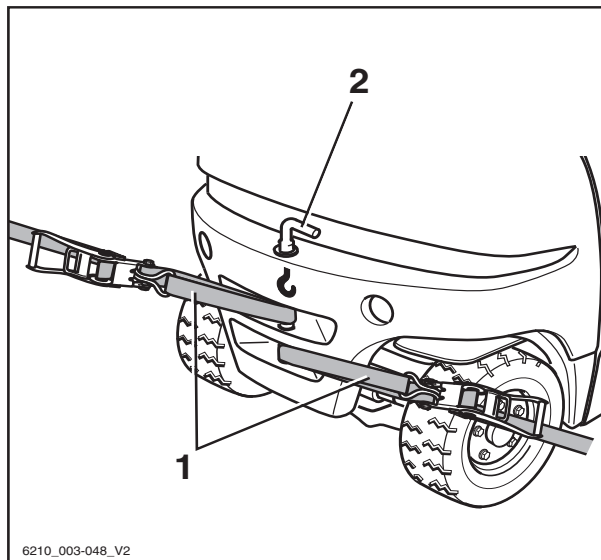

DANGER

Shifting of the load caused by the lashing straps slipping!

The truck must be lashed securely so that it cannot move during transportation.

- Make sure that the lashing straps are tightened securely and that the pads cannot slip off.

Crane loading

Crane loading is only intended for transporting the complete truck, including the lift mast, for its initial commissioning. For application conditions that require frequent loading or

that are not dealt with here, please contact the manufacturer with regard to special equipment variants.

Trucks may only be laden by persons with sufficient experience in the suitable harnesses and hoists.

Determining the loading weight

- Park the truck securely; see chapter "Parking the truck securely".
- Determine the unit weights by reading them off the truck nameplate and, if necessary, the attachment (variant) nameplate.
- Add the determined unit weights to obtain the loading weight of the truck:

Tare weight (1)

+ Max. permissible battery weight (2)

+ Ballast weight (variant) (3)

+ Attachment net weight (variant)

= Loading weight

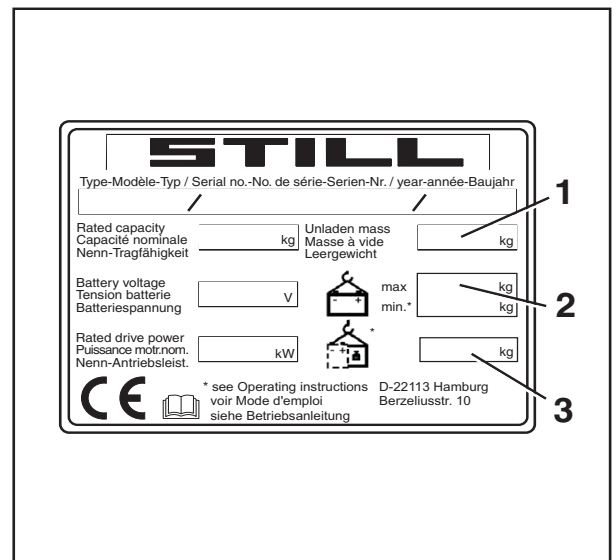

Hooking on the lifting straps

CAUTION

Harnesses may damage the truck's paintwork!
 Harnesses may damage paintwork by chafing and pressing on the surface of the truck. Particularly hard or sharp-edged harnesses, such as wires or chains, can quickly damage the surface.

- Use textile harnesses, e.g. lifting straps, with edge protectors or similar protective devices if necessary.

4 Operation

Transporting the truck



DANGER

If the hoists and harnesses fail and cause the truck to fall, the consequences are potentially fatal!

- Use only hoists and harnesses with sufficient load capacity for the determined loading weight.
- Only use the truck's designated lifting points.
- Make sure that harnesses such as hooks, shackles, belts etc. are only used in the indicated load direction.
- The harnesses must not be damaged by truck parts.

i NOTE

The attachment points are indicated by a hook symbol.

- Loop the lifting straps around the main traverse (4) on the outer mast of the lift mast.

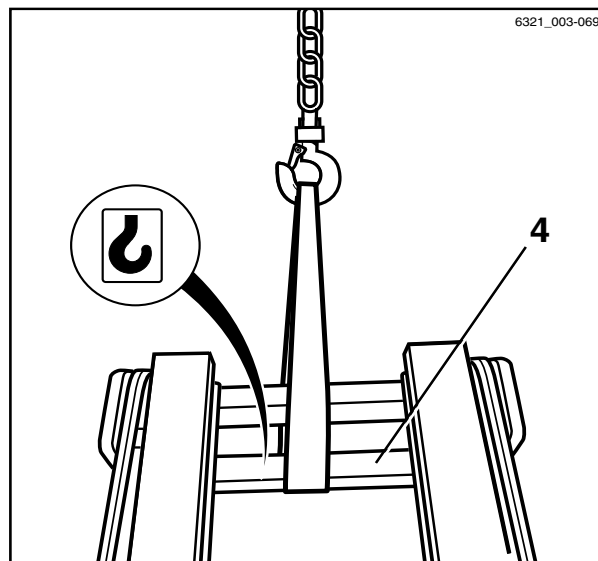

Operation

4

Transporting the truck

- Loop the lifting straps around the counter-weight (5) as shown.
- Determine the truck's centre of gravity, see "Dimensions" chapter.

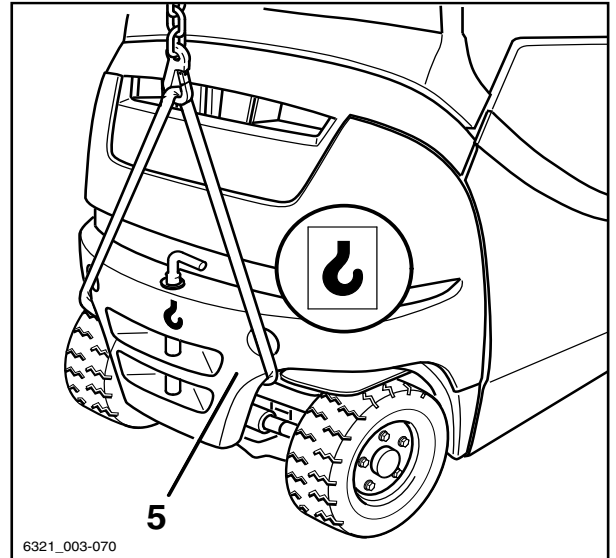

- Adjust the length of the harnesses so that the lifting eye (6) is vertically above the truck's centre of gravity.

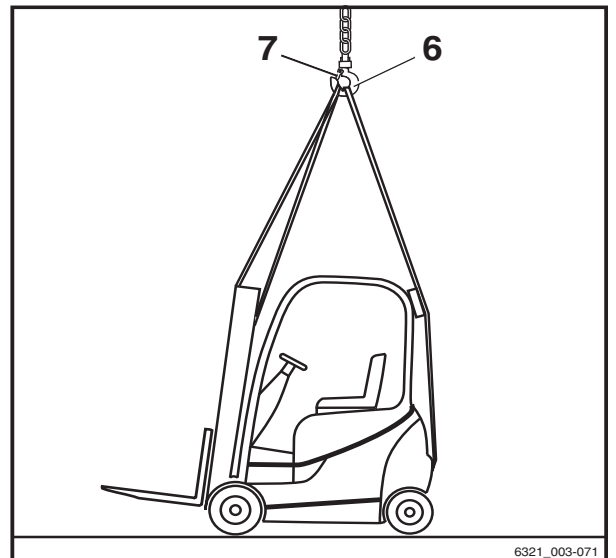

This ensures that the truck hangs level when lifting it.

- Connect the lifting straps to the lifting eye and insert the safety device (7).

⚠ CAUTION

Incorrectly fitted harnesses may damage attachment parts!

Pressure from the harnesses can damage or destroy attachment parts when the truck is lifted. If attachment parts are in the way (e.g. lighting, rear window, trademark emblem etc.), these must be removed before loading.

- Secure harnesses in such a way that they do not touch any attachment parts.

- Check that harnesses cannot collide with attachment parts.

4 Operation

Decommissioning

Loading the truck



⚠ DANGER

If the raised truck swings in an uncontrolled fashion, it may crush people. There is a risk to life!

- Never walk or stand underneath suspended loads.
- Do not allow the truck to bump into anything whilst it is being lifted, or allow it to move in an uncontrolled way.
- If necessary, hold the truck using guide ropes.

- Carefully lift the truck and set it down at the intended location.

Decommissioning

Decommissioning and storing the truck

⚠ CAUTION

Component damage through incorrect storage!

Improper storage or decommissioning for a period of more than two months can result in corrosion damage to the truck. If the truck is parked in an ambient temperature of below -10°C for an extended period, the batteries will cool down. The electrolyte may freeze and damage the batteries.

- Store the truck in a dry, clean, frost-free and well-ventilated environment.
- Implement the following measures before decommissioning.

Measures to be implemented before decommissioning

- Clean the truck thoroughly, see the chapter entitled "Cleaning the truck".
- Lift the fork carriage to the stop several times.
- Tilt the lift mast forwards and backwards several times and, if fitted, move the attachment repeatedly.

- To relieve the strain on the load chains, lower the fork onto a suitable supporting surface, e.g. a pallet.
- Check the hydraulic oil level. Top the oil up if necessary.
- Apply a thin layer of oil or grease to all uncoated moving parts.
- Lubricate the truck.
- Lubricate the joints and controls.
- Lubricate the slide elements and guides of the hydraulic battery carrier (variant); see the section entitled "Lubricating the slide elements" in the chapter entitled "1000-hour maintenance/annual maintenance".
- Lubricate the catch rail of the hydraulic battery carrier (variant); see the section entitled "Oiling the catch rails" in the chapter entitled "1000-hour maintenance/annual maintenance".
- Lubricate the battery interlock and the battery cover; see the section entitled "Checking the battery interlock and battery cover" in the chapter entitled "Remaining ready for operation".

⚠ CAUTION

Risk of component damage!

If you remove the battery male connector with the key switch switched on (under load), an arc will be produced. This can cause the contacts to erode, which considerably shortens their service life.

- Switch off the key switch before disconnecting the battery male connector.
- Do not disconnect the battery male connector while the key switch is switched on, except in an emergency.

-
- Disconnect the battery male connector.
 - Check the battery condition, acid level and acid density.
 - Service the battery.

i NOTE

Store only fully charged batteries.



Decommissioning

- Apply a suitable contact spray to all exposed electrical contacts.

⚠ CAUTION

Tyre deformation as a result of continuous loading on one side!

Have the truck raised and jacked up by the authorised service centre so that all wheels are off the ground. This prevents permanent deformation of the tyres.

- Only have the truck raised and jacked up by the authorised service centre.

⚠ CAUTION

Risk of damage from corrosion due to condensation on the truck!

Many plastic films and synthetic materials are watertight. Condensation water on the truck cannot escape through these covers.

- **Do not** use plastic film as this facilitates the formation of condensation water.
- Cover with vapour-permeable material, e.g. cotton.

- Cover the truck to protect it from dust.
- If the truck is to be shut down for even longer periods, contact the authorised service centre to find out about additional measures.

Returning to service after decommissioning

If the truck has been decommissioned for longer than six months, it must be carefully checked before being re-commissioned. As with the annual safety inspection, this check should also include all safety-related aspects of the truck.

- Clean the truck thoroughly, see the chapter entitled "Cleaning the truck".
- Lubricate the joints and controls.
- Lubricate the slide elements and guides of the hydraulic battery carrier (variant); see the section entitled "Lubricating the slide elements" in the chapter entitled "1000-hour maintenance/annual maintenance".



- Lubricate the catch rail of the hydraulic battery carrier (variant); see the section entitled "Oiling the catch rails" in the chapter entitled "1000-hour maintenance/annual maintenance".
- Check the battery condition, acid level and acid density.
- Check the hydraulic oil for condensation water. Change the hydraulic oil if necessary.
- Carry out the checks and tasks that are to be performed before the first commissioning.
- Perform "visual inspections and function checking".

The following points must be checked in particular:

- Drive, control, steering
- Brakes (service brake, parking brake)
- Lifting system (lifting accessories, load chains, mounting)

 **NOTE**

For further information, see the workshop manual for the truck or contact the authorised service centre.



4

Decommissioning

Operation



5

Maintenance



Safety regulations for maintenance

Safety regulations for maintenance

General information

To prevent accidents during maintenance and repair work, all necessary safety measures must be taken, e.g.:

- Apply the parking brake.
- Turn off the key switch and remove the key.
- Disconnect the battery male connector.
- Ensure that the truck cannot move unintentionally or start up inadvertently.
- If required, have the truck jacked up by the authorised service centre.
- Have the raised fork carriage or the extended lift mast secured against accidental lowering by the authorised service centre.
- Insert an appropriately sized wooden beam as an abutment between the lift mast and the cab, and secure the lift mast to prevent it tilting backwards unintentionally.
- Observe the maximum lift height of the lift mast, and compare the dimensions from the technical data with the dimensions of the hall into which the truck is to be driven. These steps are taken to prevent a collision with the ceiling of the hall and to avoid any damage caused as a result.

Working on the hydraulic equipment

The hydraulic system must be depressurised prior to all work on the system.

Working on the electrical equipment

Work may only be performed on the electrical equipment of the truck when it is in a voltage-free state. Function checks, inspections and adjustments on energised parts must only be performed by trained and authorised persons, taking the necessary precautions into account. Rings, metal bracelets etc. must be removed before working on electric components.



To prevent damage to electronic systems with electronic components, such as an electronic driving regulator or lift control, these components must be removed from the truck prior to the start of electric welding.

Work on the electrical system (e.g. connecting a radio, additional headlights etc.) is only permitted with approval from the authorised service centre.

Safety devices

After maintenance and repair work, all safety devices must be reinstalled and tested for operational reliability.

Set values

The device-dependent set values must be observed when making repairs and when changing hydraulic and electrical components. These are listed in the appropriate sections.

Lifting and jacking up

DANGER

There is a risk to life if the truck tips over!

If not raised and jacked up properly, the truck may tip over and fall off. Only the hoists specified in the workshop manual for this truck are allowed and are tested for the necessary safety and load capacity.

- Only have the truck raised and jacked up by the authorised service centre.
- Only jack the truck up at the points specified in the workshop manual.

The truck must be raised and jacked up for various types of maintenance work. The authorised service centre must be informed that this is to take place. Safe handling of the truck and the corresponding hoists is described in the truck's workshop manual.

Safety regulations for maintenance

Working at the front of the truck

⚠ DANGER

Risk of accident!

If the lift mast or fork carriage is raised, no work may be performed on the lift mast or at the front of the truck unless the following safety measures are observed.

- When securing, only use chains with sufficient load-bearing capacity.
- Contact the authorised service centre.

⚠ CAUTION

Possibility of damage to the ceiling!

- Note the maximum lift height of the lift mast.

Securing the lift mast against tilting backwards

A hardwood beam with a cross-section of 120 x 120 mm is required. The length of the hardwood beam must approximately correspond to the width of the fork carriage (b3). To avoid impact injuries, the hardwood beam must not protrude beyond the outer contour of the truck. A maximum length matching the total width (b1) of the truck is recommended.

- Obtain the dimensions (b1) and (b3) from the corresponding VDI datasheet.

- Clamp the hardwood beam (1) between the driver protection structure (2) and the lift mast (3).

Removing the lift mast

⚠ DANGER

Risk of accident!

This work must only be performed by an authorised service technician.

- Arrange for an authorised service technician to remove the lift mast.

Securing the lift mast against falling off

⚠ DANGER

Risk of accident!

This work must only be performed by an authorised service technician.

- Arrange for an authorised service technician to secure the lift mast.

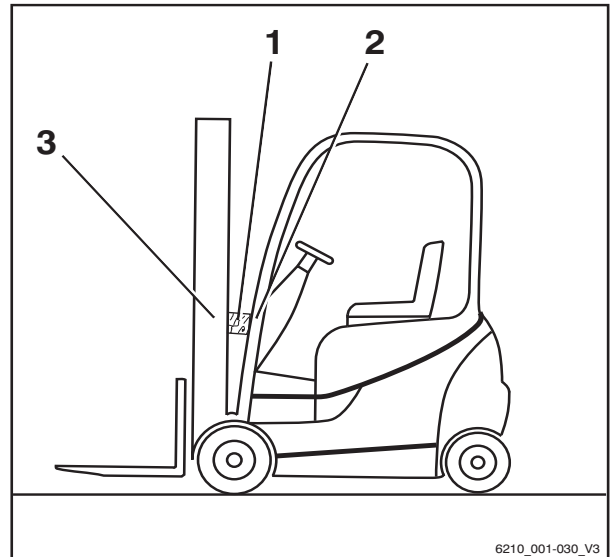



General maintenance information

General maintenance information

Personnel qualifications

Only qualified and authorised personnel are allowed to perform maintenance work. Regular safety checks and checks after unusual incidents must be performed by a competent person. The competent person must conduct their evaluation and assessment from a safety standpoint, unaffected by operational and economic conditions. The competent person must have sufficient knowledge and experience to be able to assess the condition of a truck and the effectiveness of the protective devices in accordance with technical conventions and the principles for testing trucks.

Maintenance personnel for batteries

Batteries may only be charged, serviced, and replaced by personnel who have received appropriate training in accordance with the instructions from the manufacturers of the battery, battery charger and truck.

- Follow the handling instructions for the battery and the operating instructions for the battery charger.

Maintenance work without special qualifications

Simple maintenance work, such as checking the hydraulic oil level, may be carried out by untrained personnel. A qualification such as those held by a competent person is not required to carry out this work. The required tasks are described in the chapter entitled "Remaining ready for operation".

Information for carrying out maintenance

This section contains all information required to determine when the truck needs maintenance. Carry out maintenance work within the time limits according to the hour meter and using the following maintenance check lists. This is the only way to ensure that the truck remains ready for operation and provides op-

timal performance and service life. It is also a precondition for any warranty claims.

Maintenance timeframe

- Carry out maintenance work on the truck in accordance with the "Service in" display (1).
- The maintenance check lists indicate the maintenance work that is due.

The intervals are defined for standard use. Shorter maintenance intervals can be defined in consultation with the operating company, depending on the application conditions of the truck.

The following factors may necessitate shorter maintenance intervals:

- Contaminated, poor quality roads
- Dusty or salty air
- High levels of air humidity
- Extremely high or low ambient temperatures, or extreme changes in temperature
- Multi-shift operation with a high duty cycle
- Specific national regulations for the truck or individual components

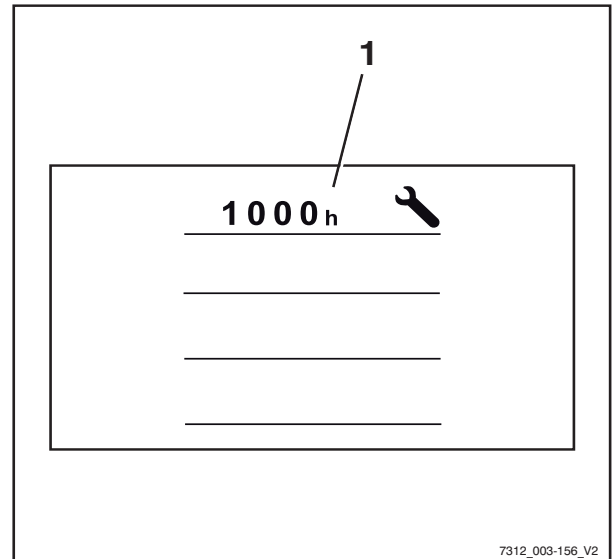



5

Maintenance

General maintenance information



Maintenance — 1000 hours/annually

At operating hours									Carried out	
1000		2000		4000		5000		7000		
8000		10000		11000		13000		14000	✓	✗
Chassis, bodywork and fittings										
Check chassis for cracks										
Check overhead guard/cab and panes of glass for damage										
Check controls, switches and joints for damage, and apply grease and oil										
Check driver's seat for correct function and for damage										
Check driver restraint system for correct function and for damage, and clean.										
Check the signal horn										
Variant: Check the dual-pedal variant for damage and correct function, and lubricate										
Tyres and wheels										
Check tyres for wear and check the air pressure if necessary										
Check wheels for damage and check the tightening torques										
Power unit										
Drive axle: Check mounting, check for leaks, and clean cooling fins										
Drive wheel unit and multi-disc brake: Check the oil level										
Change the gearbox oil (once after the first 1000 hours)										
Steering										
Check steering system for correct function and for leaks										
Check that the steering wheel is firmly attached and check the turning handle for damage										
Steering axle: Check that it is firmly attached, check for leaks, and apply grease										
Check steering stop										
Brake										
Check all mechanical brake parts for condition and correct function										
Carry out brake test										
Variant: Check the electric parking brake variant for damage and correct function										
Variant: Electric parking brake: Check the relubrication device										
Electrical system										
Check all power cable connections										
Check main contactor contacts										



5

Maintenance

General maintenance information

At operating hours								Carried out			
1000		2000		4000		5000		7000		✓	✗
8000		10000		11000		13000		14000			
Test switches, transmitters and sensors for correct function											
Check lighting and indicator lights											
Battery and accessories											
Check the lead-acid battery for damage and check the acid density; observe the manufacturer's maintenance instructions											
Variant: Lead-acid battery with electrolyte circulation: Replace the non-return valve											
Variant: Lithium-ion battery: Observe the manufacturer's maintenance instructions											
Check the appliance plug and truck harness for damage											
Check the battery male connector and battery harness for damage											
Battery compartment											
Check that the battery door, and the sensor if necessary, is working correctly and check for damage.											
Check the battery lock for damage.											
Variant: Hydraulic battery carrier: Check all moving parts for wear, and oil or lubricate. Observe the special maintenance schedule											
Variant: Hydraulic battery carrier: Check the oil level and check for leaks											
Hydraulics											
Check hydraulic system for condition, correct function and leaks											
Check the hydraulics blocking function (ISO valve)											
Check oil level											
Lift mast											
Check mast bearings for damage, and lubricate. Check the tightening torque											
Check mast profiles for damage and wear, and lubricate											
Check load chains for damage and wear, adjust and lubricate											
Check lift cylinders and connections for damage and leaks											
Check guide pulleys for damage and wear											
Check support rollers and chain rollers for damage and wear											
Check the play between the fork carriage stop and run-out barrier											
Check tilt cylinders and connections for damage and leaks											
Check fork carriage for damage and wear											
Check fork arm interlock for damage and correct function											



Maintenance

5

General maintenance information

At operating hours									Carried out	
1000		2000		4000		5000		7000		
8000		10000		11000		13000		14000	✓	✗
Check fork arms for wear and deformation										
Check that there is a safety screw on the fork carriage or on the attachment										
Special equipment										
Check the condition of the antistatic belt or antistatic electrode.										
Check heating system for damage; observe manufacturer's maintenance instructions										
Check attachments for wear and damage; observe manufacturer's maintenance instructions										
Check trailer coupling for wear and damage; observe manufacturer's maintenance instructions										
General										
Read out error numbers and delete list										
Reset maintenance interval										
Check labelling for completeness										
Test drive the truck										



5 Maintenance
General maintenance information



Maintenance - 3000 hours/every two years

At operating hours								Carried out		
3000		6000		9000		12000		15000	✓	✗
Note										
Perform all 1000-hour maintenance work										
Power unit										
Drive wheel unit and multi-disc brake: Change the gearbox oil										
Replace the bleeder screws on the drive wheel units										
Brake										
Variant: Electric parking brake: Replace the actuation push button										
Hydraulics										
Renew the hydraulic oil										
Replace the return line filter and breather filter										
Variant: Replace the high-pressure filter										
For RX60-50 LSP600 (6330) only: Replace the accumulator										

Ordering spare parts and wearing parts

Spare parts are provided by our spare parts service department. The information required for ordering parts can be found in the spare parts list.

Only use spare parts as per the manufacturer's instructions. The use of unapproved spare parts can result in an increased risk of accidents due to insufficient quality or incorrect assignment. Anyone using unapproved spare parts shall assume unlimited liability in the event of damage or harm.

Quality and quantity of the required operating materials

Only the operating materials specified in the maintenance data table may be used.

- The required consumables and lubricants can be found in the maintenance data table.

**5****Maintenance****General maintenance information**

Oil and grease types of a different quality must not be mixed. This negatively affects the lubricity. If a change between different manufacturers cannot be avoided, drain the old oil thoroughly.

Before carrying out lubricating work, filter changes or any work on the hydraulic system, carefully clean the area around the part involved.

When topping up working materials, use only clean containers!

Lubrication plan

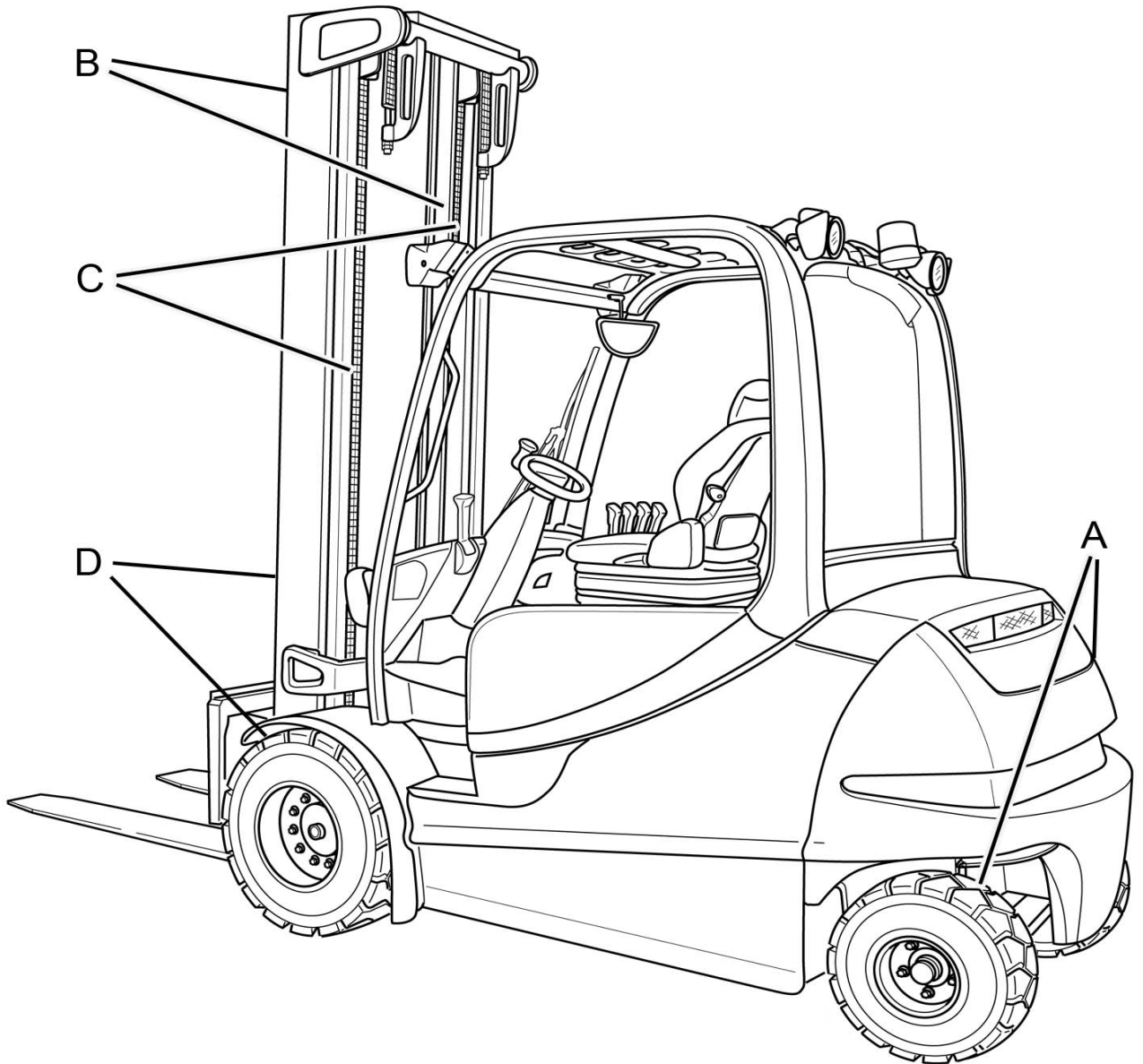

Code ¹	Lubrication point
(A)	Four lubricating nipples on each side of the steering axle for the axle stub bearing and track rod bearings
(B)	Sliding surfaces on the lift mast
(C)	Load chains



5 **Maintenance**

General maintenance information

Code¹	Lubrication point
(D)	One lubricating nipple on each of the two lift mast bearings
<p>¹The respective lubricant specification can be found in the "Maintenance data table" section below, under this Code. This lubrication plan describes the series-production truck with standard equipment. For maintenance points on variant trucks, see the relevant chapter and/or instructions provided by the manufacturer.</p>	

Maintenance

5

General maintenance information

Maintenance data table

General lubrication points

Code	Unit	Operating materials	Specifications	Quantity
	Lubrication	High-pressure grease	ID no. 0147873	As required

Battery

Code	Unit	Operating materials	Specifications	Quantity
	System contents	Distilled water		As required
	Insulation resistance		DIN 43539 VDE 0510	For further information, refer to the workshop manual for the truck in question.

Electrical system

Code	Unit	Operating materials	Specifications	Quantity
	Insulation resistance		DIN EN 1175 VDE 0117	For further information, refer to the workshop manual for the truck in question.

Controls/joints

Code	Unit	Operating materials	Specifications	Quantity
	Lubrication	High-pressure grease	ID no. 0147873	As required
		Oil	SAE 80 MIL-L2105 API-GL4	As required

Hydraulic system

Code	Unit	Operating materials	Specifications	Quantity
	System contents	Hydraulic oil	HVLP 68 DIN 51524, part 3	Max. 47.5 l
		Hydraulic oil for the food industry (variant)	USDA H1 DIN 51524	Max. 47.5 l
		Hydraulic oil for cold store application	HVLP 68 DIN 51524, part 3	Max. 47.5 l

5

Maintenance

General maintenance information

Hydraulic battery carrier

Code	Unit	Operating materials	Specifications	Quantity
	Catch rail	Multi-purpose oil, acid-free, resin-free	Rivolta TRS Plus ID no. 0149847	As required
	Slide elements and guide rails	High-pressure grease	ID no. 0147873	As required
	System contents	Hydraulic oil	HVLP 68 DIN 51524, part 3	Max. 1.6 l

Tyres

Code	Unit	Operating materials	Specifications	Quantity
	Superelastic tyres	Minimum tread depth		Min. 1.6 mm
		Wear limit		To wear mark

Steering axle

Code	Unit	Operating materials	Specifications	Quantity
(A)	Axle stub bearing, spherical bearing	High-pressure grease	ID no. 0147873	As required
	Wheel nuts/screws	Torque wrench		195 Nm
	Wheel hub fastening	Torque wrench		300 Nm
	Axle stub nut	Torque wrench		310 Nm

Drive axle

Code	Unit	Operating materials	Specifications	Quantity
	Wheel nuts/screws	Torque wrench		600 Nm
	Wheel gear	Mineral oil	ARAL HGS FLUID ID no. 127830	

Lift mast

Code	Unit	Operating materials	Specifications	Quantity
(B)	Lubrication	High-pressure grease	ID no. 0147873	As required
	Stop	Play		Min. 2 mm
(D)	Lift mast bearing	Grease	Aralub 4320 DIN 51825-KPF2N20 ID no. 0148659	Fill with grease until a small amount of fresh grease escapes
	Screws for the lift mast bearing	Torque wrench		290 Nm



Maintenance

5

General maintenance information

Load chains

Code	Unit	Operating materials	Specifications	Quantity
(C)	Lubrication	High-load chain spray	Fully synthetic Temperature range: -35°C to +250°C ID no. 0156428	As required

Washer system

Code	Unit	Operating materials	Specifications	Quantity
	System contents	Washer fluid	Winter, ID no. 172566	As required

5

Maintenance

Providing access to maintenance points

Providing access to maintenance points

Removing and installing the valve cover

Removing the valve cover

- For trucks with a heating system (variant), unscrew five screws (2).
- Remove the heating system panelling (3).
- If the cover (6) is in place, remove it by lifting it with your finger.
- Unscrew the four screws (5).

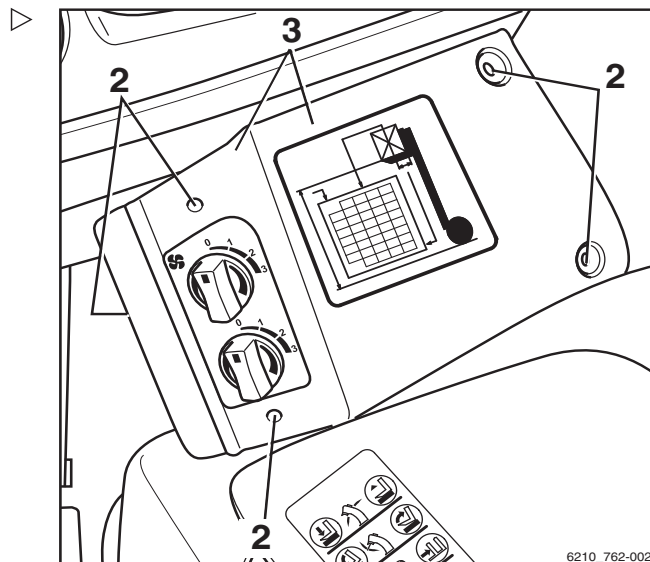

- Lift up the valve cover (4) and remove it.

Fitting the valve cover

- Refit the valve cover (4).
- Refit the cover (6).
- Refit the heating system panelling (3).

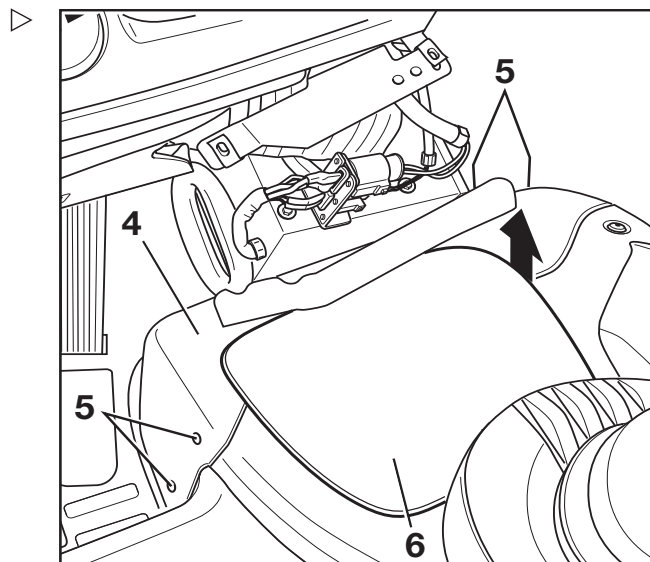

Opening the fuse box

To access the fuse box and other components in the electronic control unit, you need to remove the cover sheet (1).

Providing access to maintenance points

Removing the cover sheet

- Park the truck safely and switch it off.
- Open the battery door or battery cover.

Beneath it there is a screw.

- Remove the hexagon socket wrench from the compartment.
- Loosen two screws (2) but do not remove them completely.

The cover sheet is held in place by clamps at the sides.

- Unscrew two screws (3).
- Remove the cover sheet (1).
- To fit the cover sheet, slide it into the clamps at the sides.
- Tighten all screws.

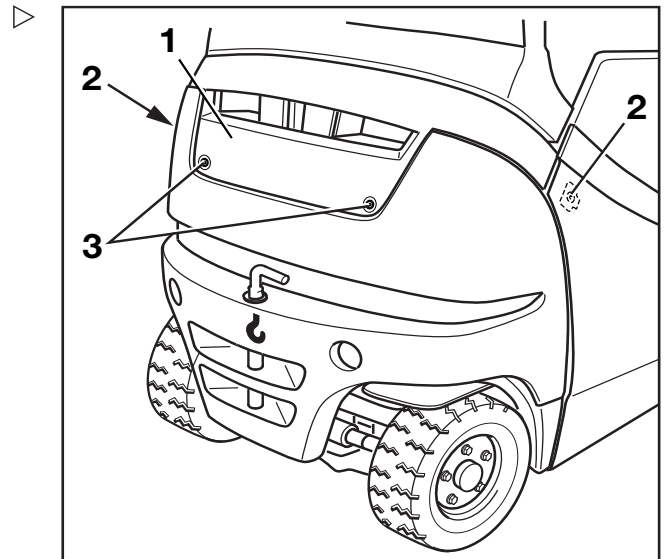

Opening the fuse box

- Unscrew the screws (5).

The screw at the side can be accessed through the open battery door or battery cover.

- Remove the fuse box cover (4).
- To fit the cover, screw in and tighten the screws again.

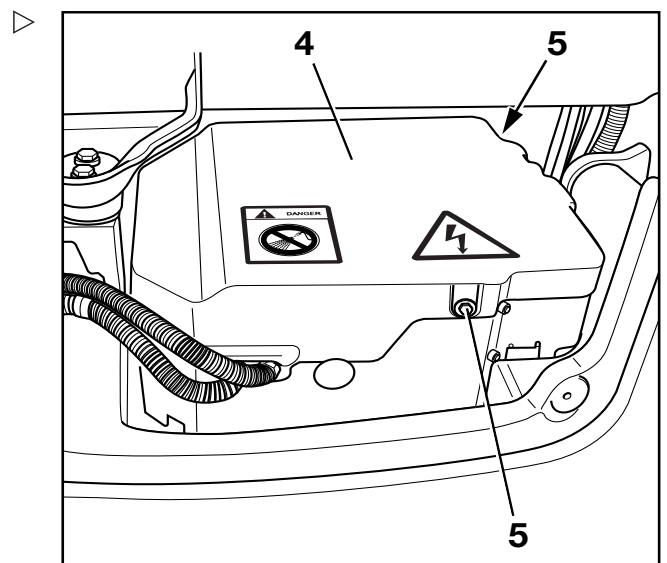

Preserving operational readiness

Preserving operational readiness

Lubricating the joints and controls

- Oil or grease bearings and joints according to the "maintenance data table".
- Driver's seat guide
- Cab door hinges (variant)
- Battery-door hinges or battery-cover hinges
- Actuating rod (1) for valves (with multi-lever operation)

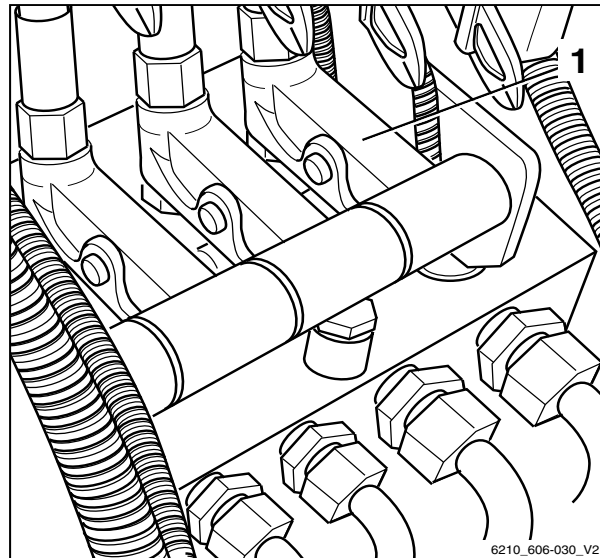

Checking the battery interlock and battery cover

⚠ DANGER

A malfunction of the battery interlock and battery cover can cause the battery cover to open and the battery could possibly fall out when the truck is tilted or during sharp deceleration. If the battery falls out there is a danger of being crushed.

- If the interlock is deformed, damaged or difficult to move, inform STILL Service immediately. Do not operate the truck.
- Check that the interlocks function correctly.
- Interlocks must be greased and move easily.
- Always check the interlock after an accident.

i NOTE

The interval for greasing is influenced significantly by the application conditions and environmental conditions affecting the truck. Every 1000 hours and as necessary visually inspect and check the function of the interlock and all of its moving parts.

- Open the battery cover; see ⇒ Chapter "Opening/closing the battery cover", P. 4-334.

Maintenance

5

Preserving operational readiness

- Check that the battery lock (1) moves easily and that it is not deformed or damaged. ▷

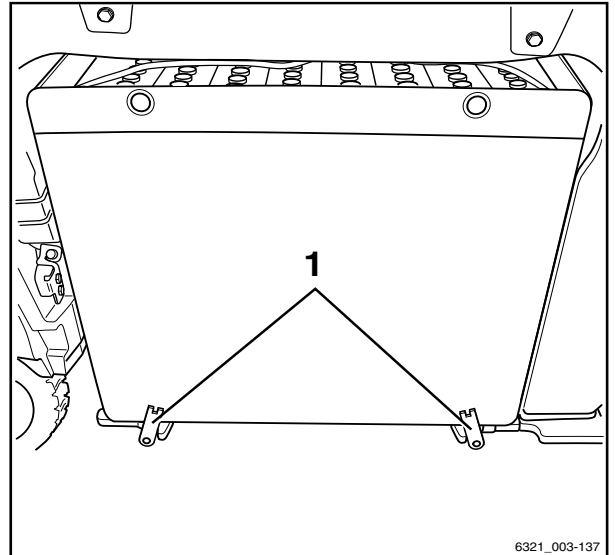

- Check that the battery cover lock (3) moves easily and that it is not deformed or damaged. ▷
- Check that the rest plate (2) of the battery cover lock is seated correctly, and that it is not deformed or damaged.
- Grease the lock mechanisms.
- Close the battery cover again.

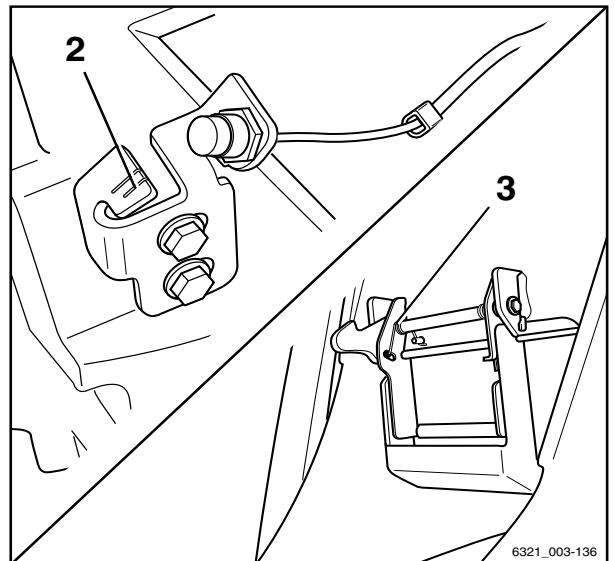

5 Maintenance

Preserving operational readiness

Maintaining the seat belt

⚠ DANGER

There is a risk to life if the seat belt fails during an accident!

If the seat belt is faulty, it may tear or open during an accident and no longer keep the driver in the driver's seat. The driver may therefore be hurled against the truck components or out of the truck.

- Ensure operational reliability by continually testing.
- Do not use a truck with a defective seat belt.
- Only have a defective belt replaced by your service centre.
- Only use genuine spare parts.
- Do not make any changes to the belt.

i NOTE

Carry out the following checks on a regular basis (monthly). In the case of significant strain, a daily check is necessary.

Checking the seat belt

- Pull out the belt (3) completely and check for wear.

The belt must not be frayed or cut. The stitching must not be loose.

- Check whether the belt is dirty.
- Check whether parts are worn or damaged, including the attachment points.
- Check the buckle (1) to ensure that it locks in properly.

When the belt tongue (2) is inserted, the belt must be held securely.

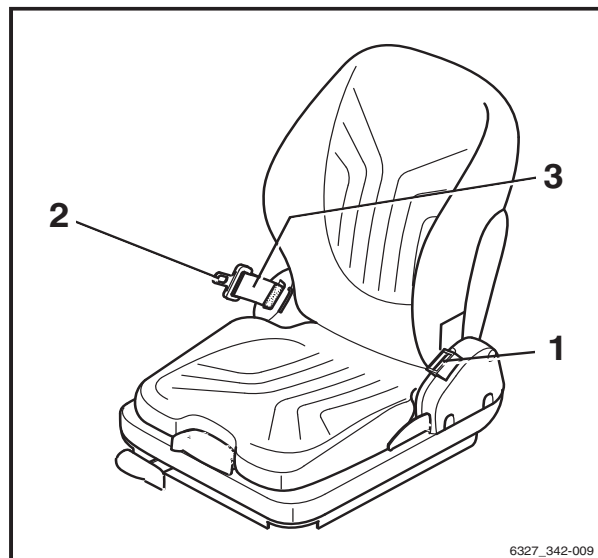

6327_342-009

Maintenance

5

Preserving operational readiness

- The belt tongue (2) must release when the red button (4) is pressed.
- The automatic blocking mechanism must be tested at least once a year:
- Park the forklift truck on level ground.
- Pull out the belt with a jerk.

The automatic blocking mechanism must block extension of the belt.

- Tilt the seat at least 30 ° (if necessary, remove the seat).
- Slowly extend the belt.

The automatic blocking mechanism must block extension of the belt.

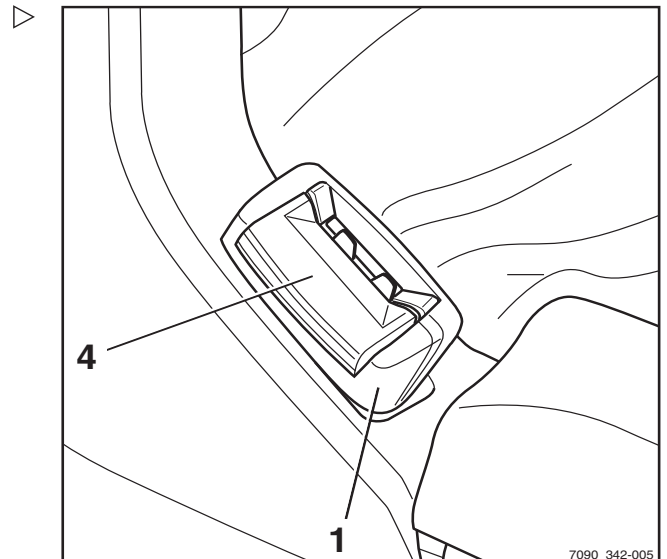

Cleaning the seat belt

- Clean the seat belt as necessary, but without using chemical cleaning materials (a brush will suffice).

Replacement after an accident

As a rule, the seat belt must be changed after an accident.

Checking the driver's seat

⚠ WARNING

Risk of injury!

- After an accident, check the driver's seat with attached restraining belt and fastening.
- Check the controls for correct operation.
- Check the condition of the seat (e.g. wear on the upholstery) and secure fastening to the hood.

⚠ WARNING

Risk of injury!

- Have the seat repaired by the service centre if you identify any damage during the checks.

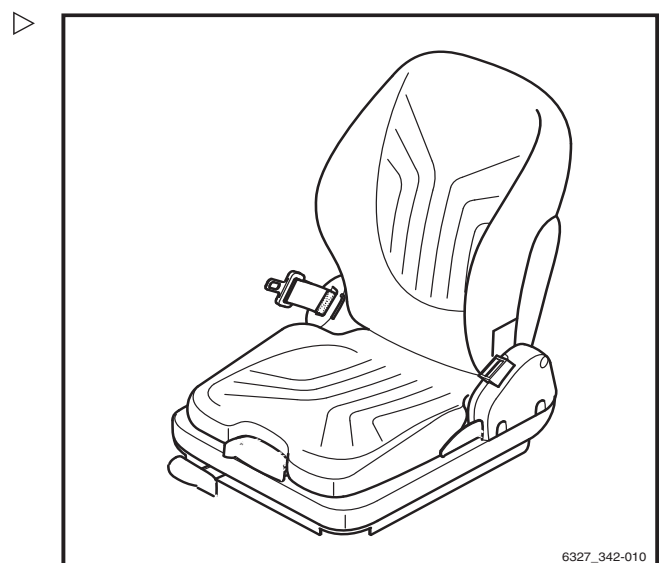

Preserving operational readiness

Maintaining wheels and tyres

⚠ WARNING

Risk of accident!
 Uneven wear reduces the stability of the truck and increases the braking distance.
 – Change worn or damaged tyres without delay.

⚠ WARNING

Risk of tipping!
 Tyre quality affects the stability of the truck.
 If you wish to use a different type of tyre on the truck from the tyres approved by the truck manufacturer, or tyres from a different manufacturer, you must first obtain approval from the truck manufacturer.

⚠ WARNING

Risk to stability!
 When using pneumatic tyres or solid rubber tyres, rim wheel parts must never be changed and rim wheel parts from different manufacturers must not be mixed.

Checking the condition and wear of the tyres

⚠ WARNING

Tyre quality affects the stability and handling of the truck.
 Changes can only be made after consultation with the manufacturer.
 When changing wheels or tyres, always ensure that this does not cause the truck to tilt to one side (e.g. always replace right-hand and left-hand wheels at the same time).

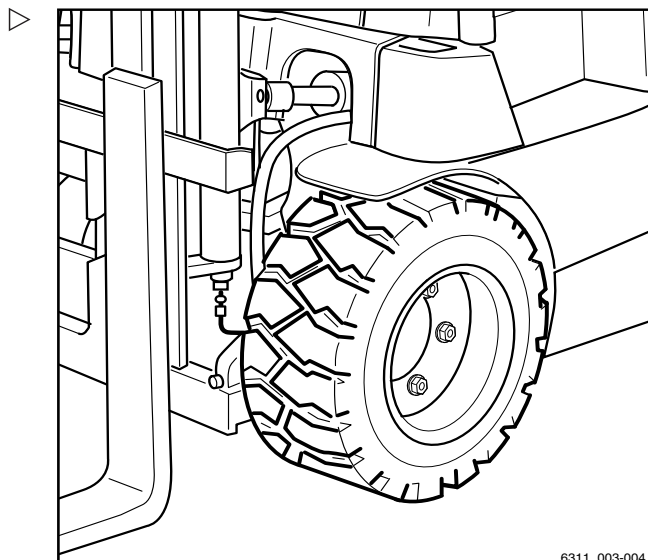

Maintenance

5

Preserving operational readiness

- If necessary, remove any foreign bodies imbedded in the tyre profile (1).

i NOTE

The wear of the tyres on an axle must be approximately the same.

- *Super elastic tyres and solid rubber tyres can be worn down to the wear mark (2)*

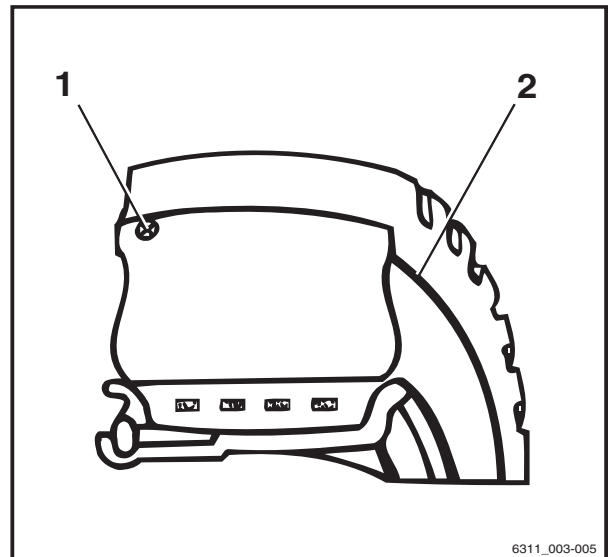

Checking wheel fastenings

- Check wheel fastening nuts (3) and bolts for secure positioning, and retighten as necessary.
- Observe the torques; see the "maintenance data table".

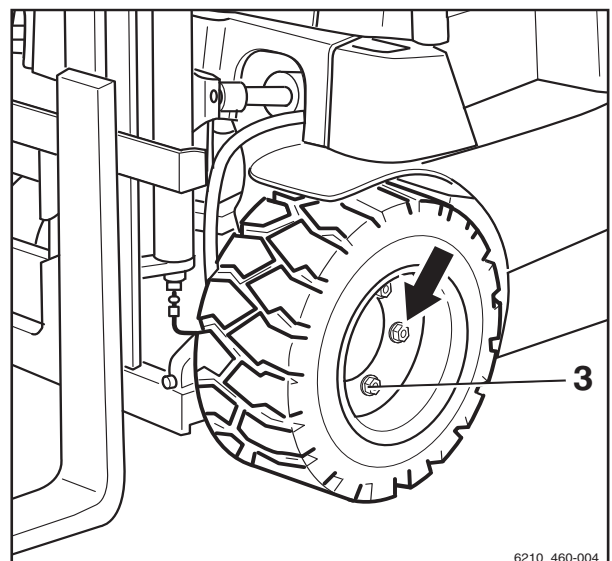

5 **Maintenance**

Preserving operational readiness

Servicing the steering axle

- Park the truck securely.

Checking the steering axle

- Check the condition and wear of the rubber parts of the axle swivel bearings. ▷
- Check the stub axle bearing (1) and tie rod joint (2) for play and wear.

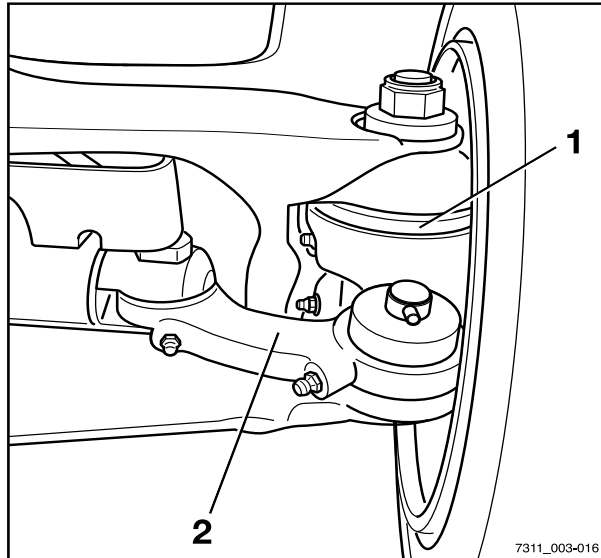

- Check the steering cylinder (3) for leaktightness (traces of oil). ▷

i NOTE

In the case of excessive play or wear, have your service centre change the relevant parts.

Lubricating the steering axle

ENVIRONMENT NOTE

Dispose of old grease and contaminated devices in accordance with the national regulations for the country in which the truck is being used.

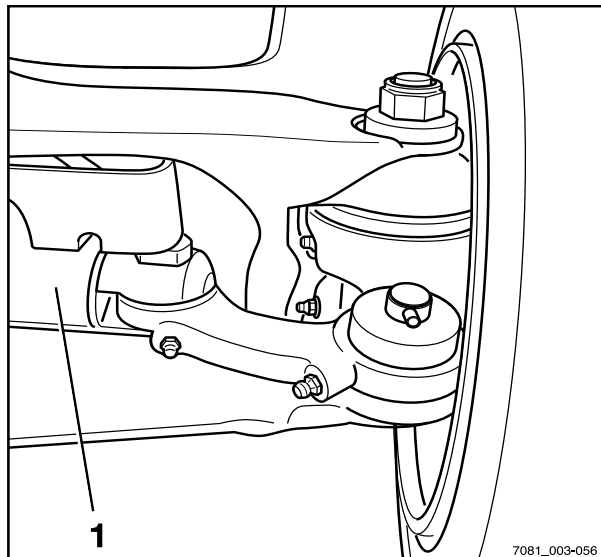

Maintenance

5

Preserving operational readiness

- At the lubricating nipples (4), lubricate the axle stub bearing and the steering lever bearings with grease in accordance with the "maintenance data table".

If, after a few strokes, there is no longer any old grease escaping, actuate the steering.

⚠ WARNING

Risk of crushing!

Do not actuate the steering during lubrication.

- Switch on the truck.
- Actuate the steering.
- Park the truck securely again.
- Repeat the lubrication procedure.

i NOTE

Please note: the more often the truck is cleaned, the more frequently it must be lubricated.

Checking the lines for leaks

- Retighten leaky connections.

i NOTE

Have faulty lines replaced by your authorised service centre.

- After repairs, force out any trapped air by turning the steering wheel from stop to stop several times.

Checking the tightening torque of the axle stub nuts

- Set steering to end stop.
- Park the truck securely again.

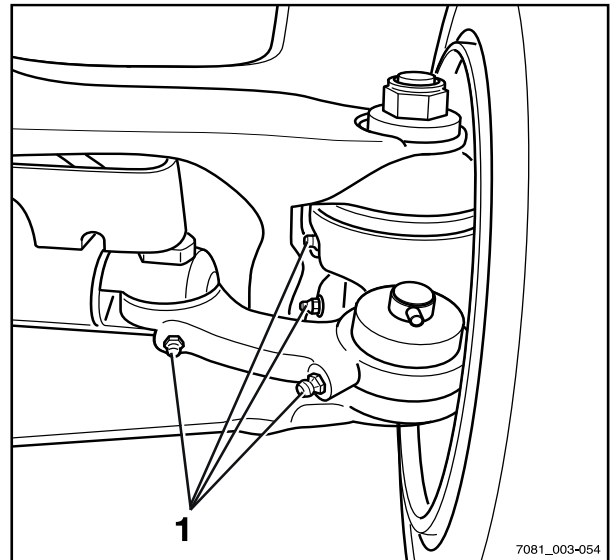

5 Maintenance

Preserving operational readiness

- Check the tightening torque of the axle stub nut (5) in accordance with the "maintenance data table" and tighten the axle stub nut as necessary.

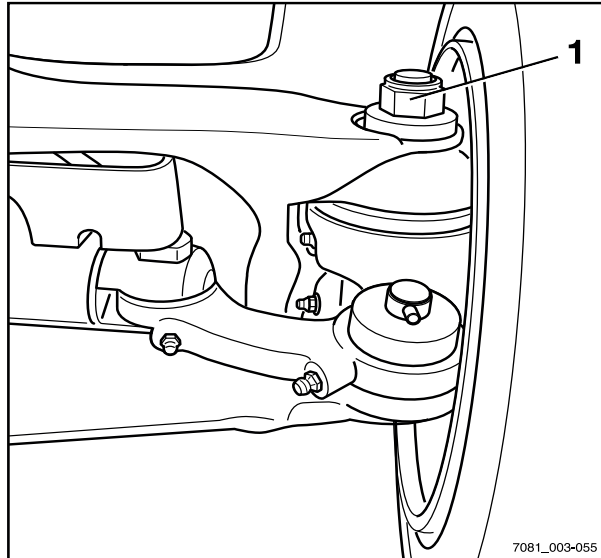

Checking the battery

- For information on checking the battery, see the chapter entitled "Checking the battery condition, acid level and acid density".

Checking the fuses



⚠ DANGER

Hazard from electrical current!

Take care when handling; residual capacity may be present.

Before starting the following maintenance work:

- Park the truck securely.
- Disconnect the battery male connector.

⚠ CAUTION

Risk of component damage!

If you remove the battery male connector when the key switch is switched on (under load), an arc will be produced. This can lead to erosion at the contacts, which considerably shortens their service life.

- Switch off the key switch before the battery male connector is disconnected.
- Do not disconnect the battery male connector while the key switch is switched on, except in an emergency.

Fuses for standard equipment and equipment variants are located in the rear part of the control electronics (1).

- Open the cover.
- Remove the cover from the control electronics.

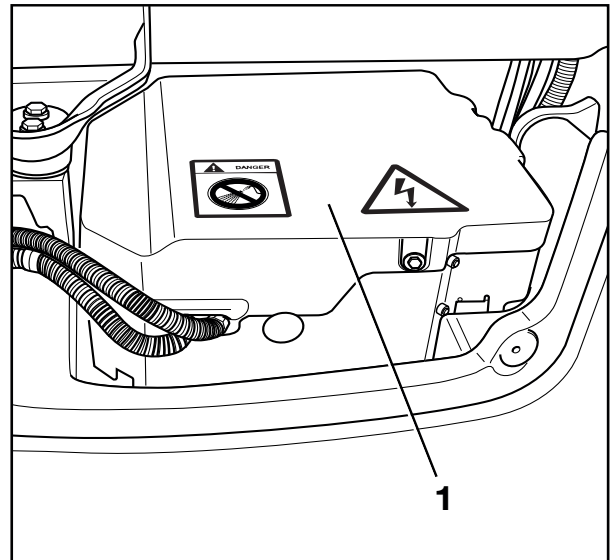

5

Maintenance

Preserving operational readiness

- Check the condition of the main fuse (2) (no damage to the porcelain body) and check that it is securely positioned; tighten the clamping screws if necessary.
- Check the condition of fuses (3) to (3), check that the cable connections are secure and check for oxidation residues. Clean if necessary.(9)

i NOTE

Depending on the specification, not all fuses will be present in the truck.



CAUTION

Water in the electrical system can cause damage to components!
In order to protect the electrical system against ingress of water, the cover must be closed.

- Refit the cover after these tasks have been completed.

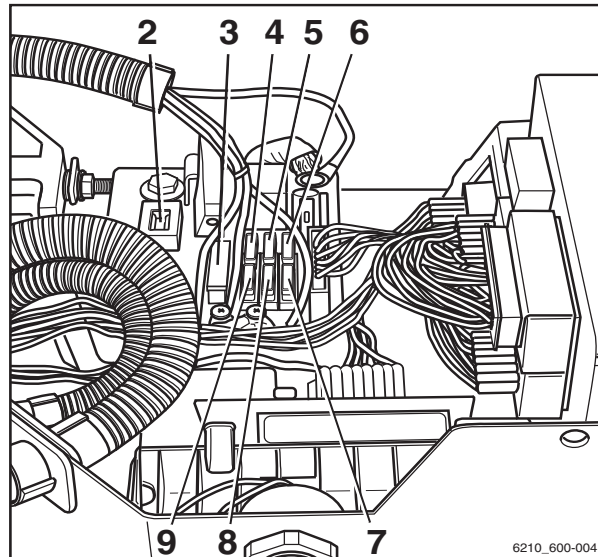

- Connect the battery male connector.
- Carry out a functional test.

Replacing fuses



DANGER

Hazard from electrical current!
Take care when handling; there may be residual capacity present.
Before starting the following maintenance work:

- Park the truck securely.
- Disconnect the battery male connector.

⚠ CAUTION

Risk of component damage!

If you remove the battery male connector when the key switch is switched on (under load), an arc will be produced. This can lead to erosion at the contacts, which considerably shortens their service life.

- Switch off the key switch before the battery male connector is disconnected.
- Do not disconnect the battery male connector while the key switch is switched on, except in an emergency.



⚠ DANGER

Risk of fire!

Using the wrong fuses can result in short circuits.

- Only use fuses with the prescribed nominal current.

i NOTE

Depending on the equipment, not all fuses will be present in the truck.

Fuses for standard equipment and equipment variants are located in the rear part of the control electronics (1).

- Open the cover.
- Remove the cover from the control electronics.
- Replace the blown fuse; see the section entitled "Fuse assignment".



⚠ CAUTION

Water in the electrical system can cause damage to components!

In order to protect the electrical system against ingress of water, the cover must be closed.

- Refit the cover after these tasks have been completed.

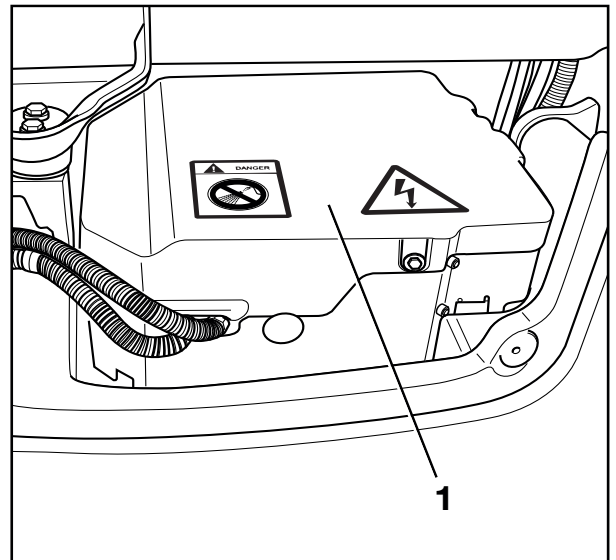

- Connect the battery male connector.
- Carry out a functional test.

5 Maintenance

Preserving operational readiness

Checking the hydraulic oil level

- Park the truck securely.

⚠ CAUTION

Risk of component damage!

If you remove the battery male connector when the key switch is switched on (under load), an arc will be produced. This can lead to erosion at the contacts, which considerably shortens their service life.

- Switch off the key switch before the battery male connector is disconnected.
- Only disconnect the battery male connector with the key switch switched on in an emergency.

- Disconnect the battery male connector.
- Remove maintenance lid or bottom plate.

⚠ CAUTION

Hydraulic oils are hazardous to your health and are under pressure during operation.

- Note the safety regulations in the "Hydraulic fluid" chapter.

⚠ CAUTION

Risk of damage to components!
Remove connector for drive unit.

- Unscrew breather filter (1).
- Check the oil level on the oil dipstick. The oil level must be between the markings (2).
- If the oil level is too low, pour hydraulic oil of the correct specification as specified in the maintenance data table into the filler neck.
- Fill the hydraulic oil no higher than the upper marking on the oil dipstick.

i NOTE

Use a funnel.

♻ ENVIRONMENT NOTE

Carefully collect up any spilled oil and dispose of it in an environmentally friendly manner.

- Screw in the breather filter with oil dipstick.
- Close maintenance lid or bottom plate.

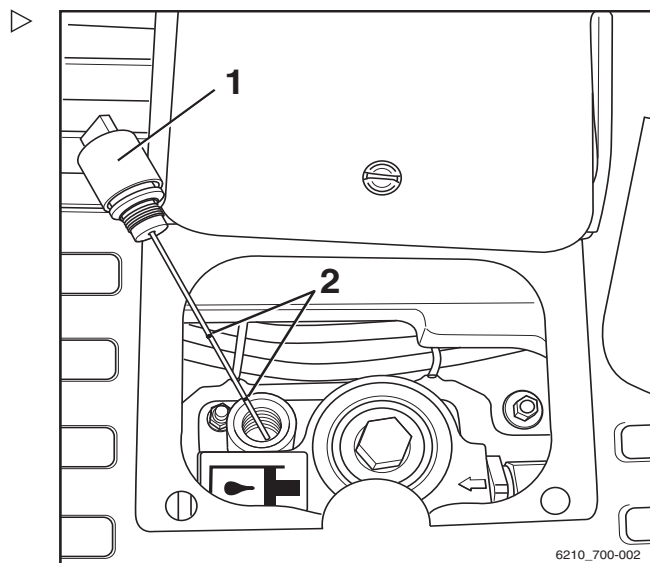

- Connect the battery male connector.

Checking the hydraulic system for leak tightness



⚠ WARNING

Hydraulic oil is hazardous to health!
Hydraulic oil under pressure can escape from leaking pipes and lines, and cause injuries.

- Wear suitable protective gloves, protection goggles etc.

⚠ CAUTION

Hydraulic hoses become brittle!

- Do not store hydraulic hoses for more than two years.
 - Do not use hydraulic hoses for more than six years if they are subject to normal wear.
 - Do not use hydraulic hoses for more than two years if they are subject to a high level of wear.
 - Comply with the specifications of DGUV 113-020 in Germany.
 - Outside of Germany, observe the national regulations for the country of use.
-
- Check pipe and hose connection screw joints for leaks (traces of oil).

Replace hose lines if they display the following abnormalities:

- Outer layer has been damaged, or is brittle or cracked
- Leaking
- Deformation (e.g. with blisters or kinks)
- A fitting has come loose
- A fitting is badly damaged or corroded

Replace pipes if they display the following abnormalities:

- Abrasion
- Deformation and bending
- Leaking

5 Maintenance

Preserving operational readiness

Lubricating the lift mast and roller track

- Remove dirt and lubricant residue from the roller track.
- Lubricate the roller tracks (1) of the outside, middle, and inside mast with a super-pressure adhesion lubricant to reduce wear. See ⇒ Chapter "Maintenance data table", P. 5-387.

i NOTE

Spray the roller track evenly from a distance of approx. 15-20 cm. Wait approx. 15 minutes until the equipment is ready to use again.

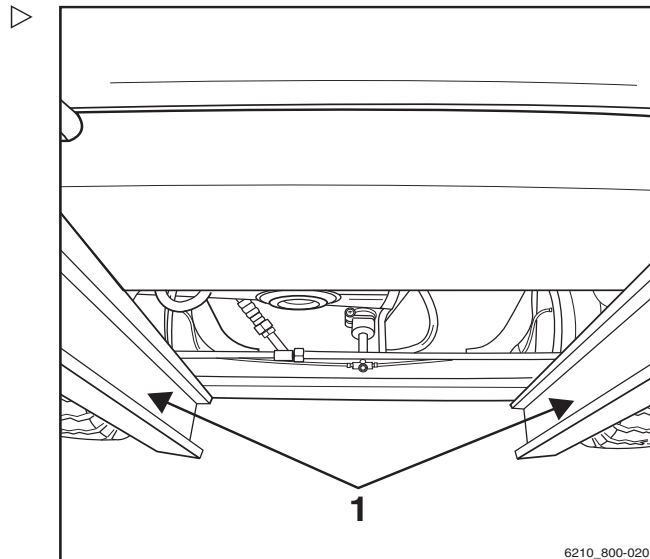

Greasing the automatic tow coupling

i NOTE

Wear to moving parts can be significantly reduced by appropriate servicing and regular lubrication of the coupling.

- Avoid over-greasing!

i NOTE

Close the coupling before cleaning with a high-pressure cleaner. After cleaning, lubricate the coupling pin, tow bar eye and its supporting surface again.

Maintenance

5

Preserving operational readiness

Model RO*243

- Pull out the safety handle (3).
- Push the hand lever (2) upwards.
- Grease using the lubricating nipple(1) in accordance with the maintenance data table; see => Chapter "Maintenance data table", P. 5-387.
- Close the coupling by raising the coupling pin with a suitable tool.
- For journeys with a rigid drawbar trailer, lubricate the underside of the tow bar eye and the supporting surface on the coupling.

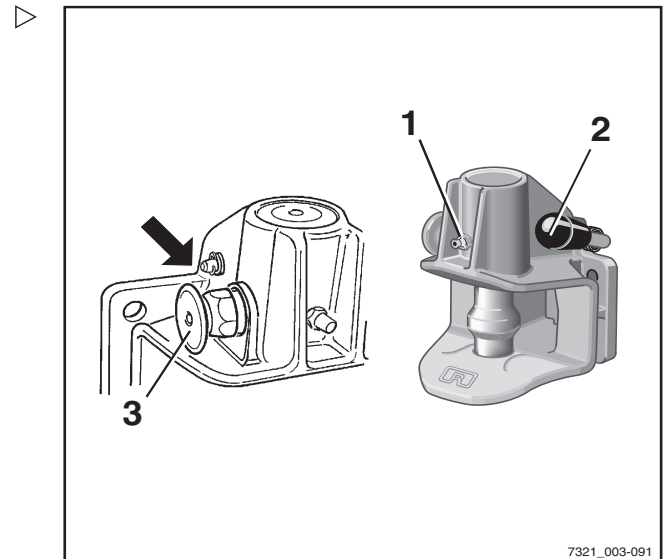

- Determine the wear on the coupling pin.
- The diameter of the spherical part must not be less than 36.5 mm.

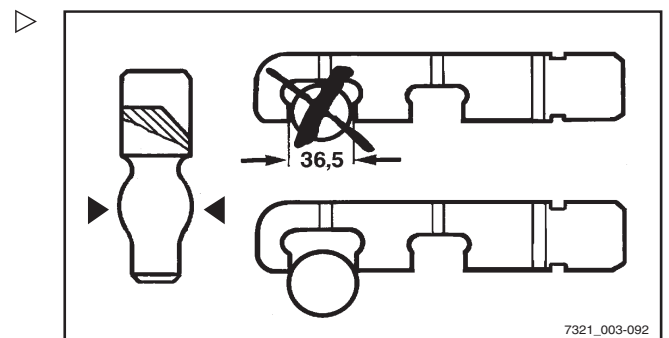

Model RO*244 A

- Open coupling.
- Grease using the lubricating nipple(1) in accordance with the maintenance data table; see => Chapter "Maintenance data table", P. 5-387.
- Grease coupling pin, tow bar eye and its supporting surface.

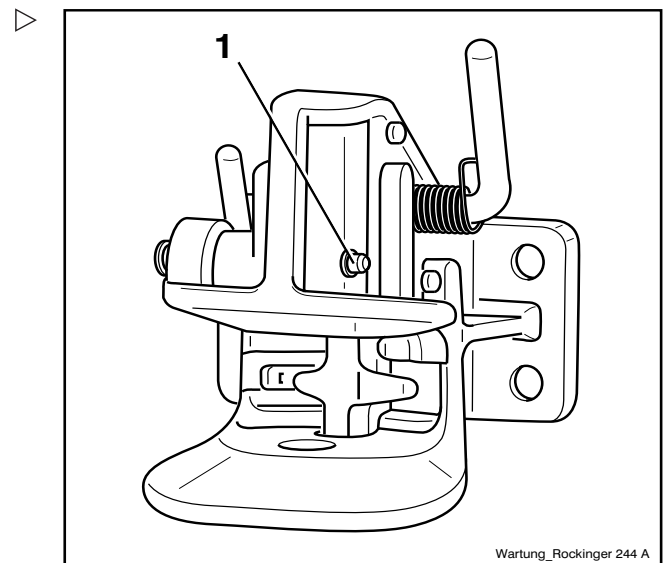

5 Maintenance

Preserving operational readiness

Model RO*245

- Lubricate via the points provided for this purpose (lubricating nipple, opened coupling) in accordance with the maintenance data table; see ⇒ Chapter "Maintenance data table", P. 5-387.
- Grease the supporting surface for the tow-bar eye.

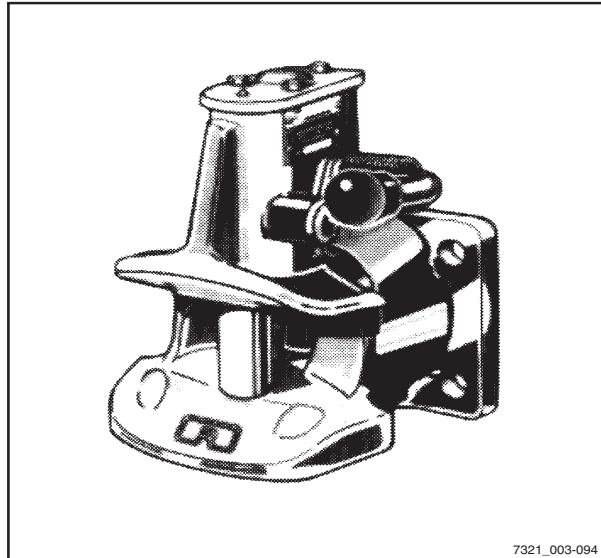

Model RO*841

- Lubricate via the points provided for this purpose (lubricating nipple, opened coupling) in accordance with the maintenance data table; see ⇒ Chapter "Maintenance data table", P. 5-387.
- Grease the supporting surface for the tow-bar eye.

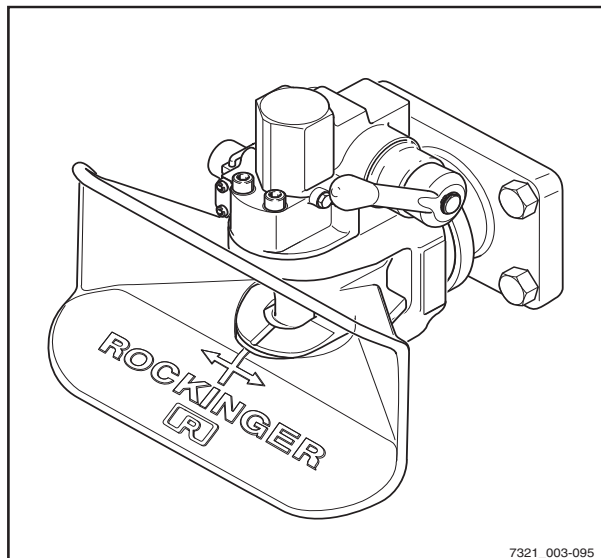

Preserving operational readiness for cold store application ▷

- On trucks for cold store application (variant), check all rollers and chains in the lift mast for ease of movement once a week.

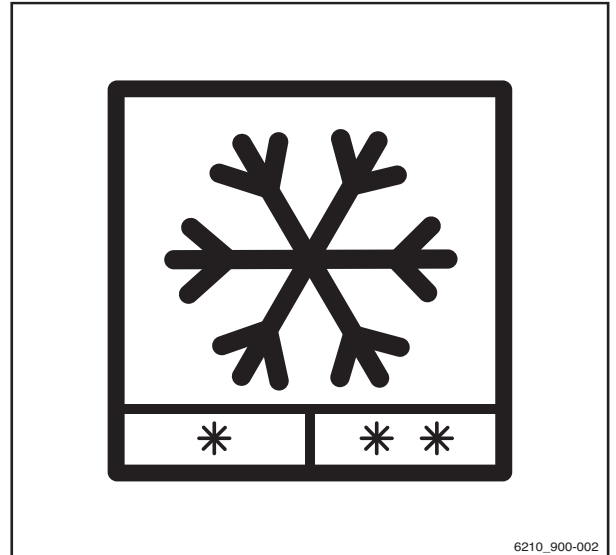

Maintaining the heater ▷

- Loosen the fixing screw (1) and remove the cover (2).

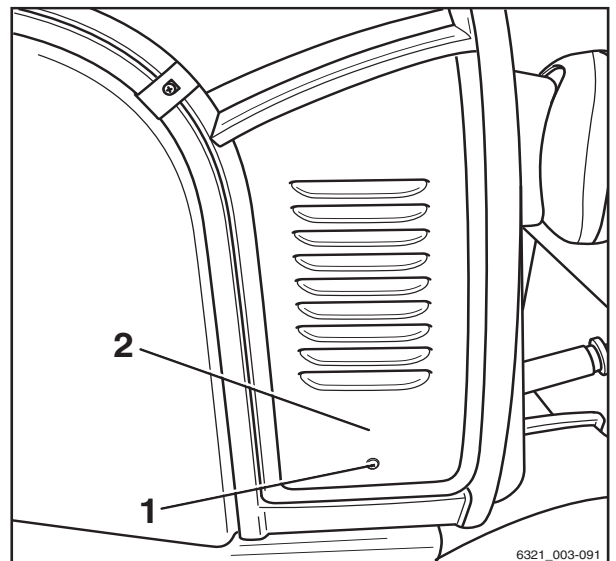

5 Maintenance

Preserving operational readiness

- Check the filter mat (3) for soiling.
If the filter mat is grey in colour, replace it.



NOTE

Change the filter mat at least every 2 months.

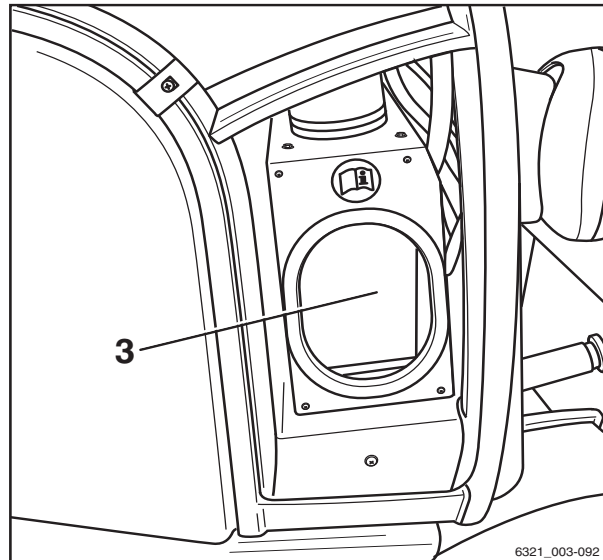

- Clean the fresh-air inlet (4) of dust and dirt.

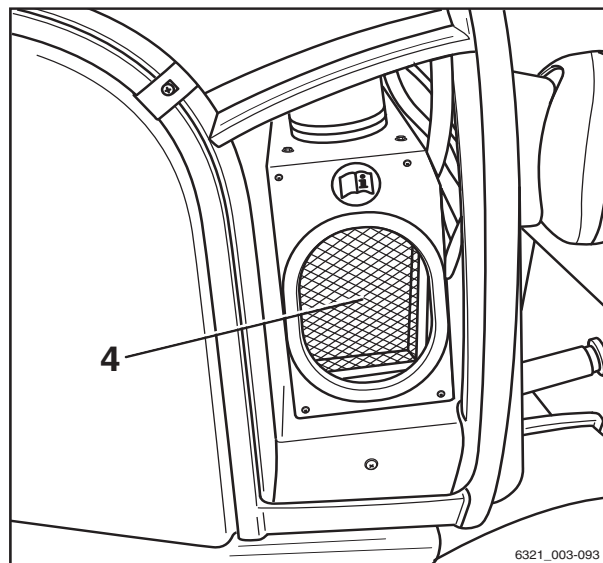

1000-hour maintenance/yearly maintenance

Other tasks

- Perform all tasks required to maintain full operability; see the chapter entitled "Remaining ready for operation".

Checking the cable connections

- Check supply cable of pump motor (1) and traction motor (2) for secure positioning, condition and insulation .

i NOTE

Oxidised connections and brittle cables lead to voltage drops , so causing malfunctions.

- Remove oxidised connections and replace brittle cables.

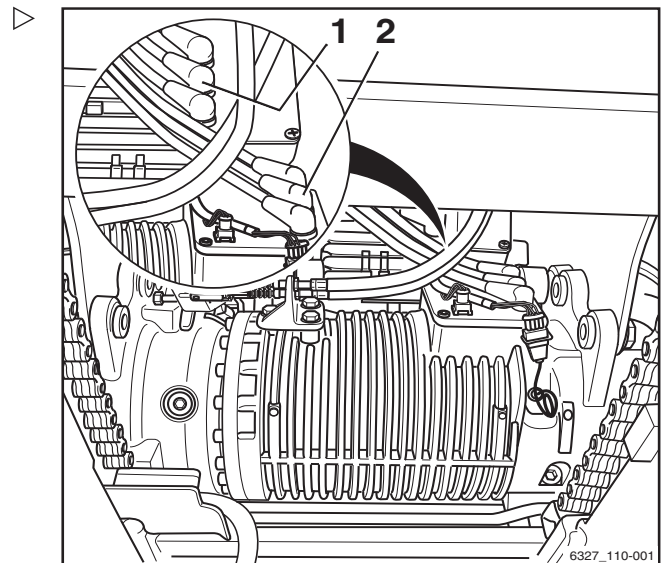

Checking the hydraulic oil level of the hydraulic battery carrier

⚠ WARNING

Hydraulic oils are hazardous to your health and are under pressure during operation.

- Note safety regulations for working with hydraulic oils; see ⇒ Chapter "Hydraulic fluid", P. 2-51.

Checking the hydraulic oil level

- Park the forklift truck on level ground.
- Remove the battery (see ⇒ Chapter "Replacing the battery with the hydraulic battery carrier", P. 4-345) and place it next to the truck so that the battery male connector can be inserted again.

The minimum distance between the battery and the truck should be > 0.5 m. This is to

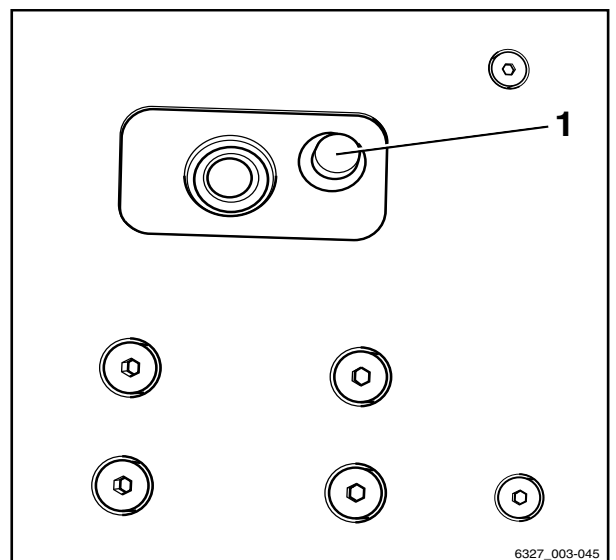

5

Maintenance

1000-hour maintenance/yearly maintenance

ensure that the hydraulic battery carrier push buttons can be accessed.

- Connect the battery plug.

⚠ WARNING

If the battery carrier is not at a sufficient safety distance from mechanical components when it is actuated hands or feet can be crushed. There is risk of injury!

- Actuating beyond the carrier is prohibited.
- It is not permitted to walk on the battery holder plate.

- Retract the hydraulic battery carrier.
- Withdraw sealing plug (1) through the opening in the mounting plate.

The oil level must lie between 65 and 70 mm when measured from the base of the container.

- If the oil level is below the required level, top up the hydraulic oil via the filler neck according to the maintenance data table (see ⇒ Chapter "Maintenance data table", P. 5-387).

i NOTE

Use a funnel.

- Screw sealing plugs (1) back in.
- Reinstall the battery.

♻ ENVIRONMENT NOTE

Carefully collect up any spilled oil and dispose of it in an environmentally friendly manner.

Lubricating the slide elements

Lubricating the slide elements

- Extend the battery with the hydraulic battery carrier and remove the battery, see ⇒ Chapter "Replacing the battery with the hydraulic battery carrier", P. 4-345.
- Remove dirt and contaminated lubricant residues.
- Lubricate the slide elements and guide rails (2) and (3) in accordance with the maintenance data table (see ⇒ Chapter "Maintenance data table", P. 5-387).
- Reinstall the battery.

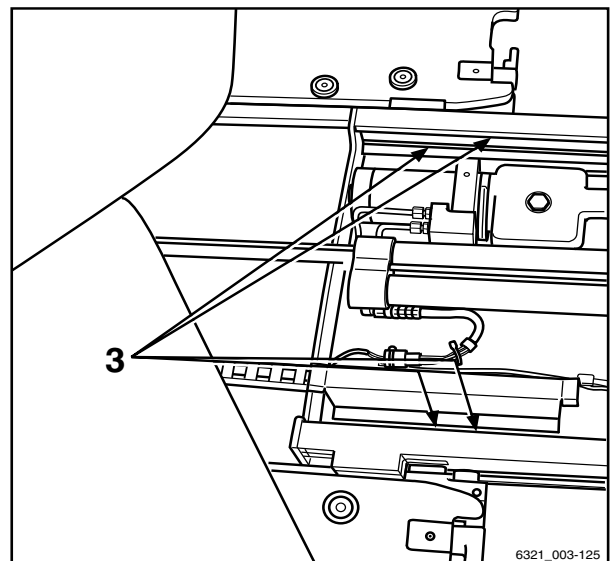
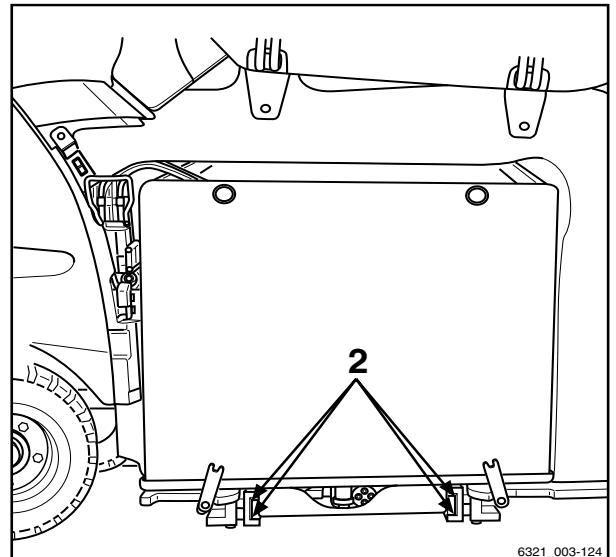

Oiling the catch rails

⚠ WARNING

Risk of injury!

If the battery carrier is not at a sufficiently safety distance from mechanical components when it is actuated, hands or feet may be crushed.

- Actuating beyond the battery carrier is prohibited.
- It is not permitted to walk on the battery holder plate.

5

Maintenance

1000-hour maintenance/yearly maintenance

⚠ WARNING

Risk of injury!

If the battery carrier is actuated while maintenance work is being carried out, hands or feet may be crushed.

- De-energise the truck before performing maintenance work.

⚠ WARNING

Risk of crushing!

If the support rollers swing away when the battery is inserted, the battery carrier with the battery can land on feet.

If the catch rails are not clean and are insufficiently oiled, there is no guarantee that the support rollers will lock correctly.

To ensure that the oil is evenly distributed and to test the functionality, fully retract and then fully extend the battery carrier once after the oiling is complete.

The support rollers must be swung out fully and locked in position after lubrication.

i NOTE

The catch rails of the support rollers are located beneath the battery carrier. If necessary use a mirror to gain a better view.

- Park the forklift truck on level ground.
- Remove the battery, see "Replacing the battery with the hydraulic battery carrier".
- Place the battery next to the truck so that the battery male connector can be reinserted.

The minimum distance between the battery and the truck must be > 0.5 m. This distance ensures that the hydraulic battery carrier actuation buttons can be accessed.

- Connect the battery male connector.
- Retract the battery carrier until the support rollers are directly underneath (the battery carrier is then extended by approx. 300 mm).
- Pull out the switch key.
- Push the emergency off switch.
- Disconnect the battery male connector.

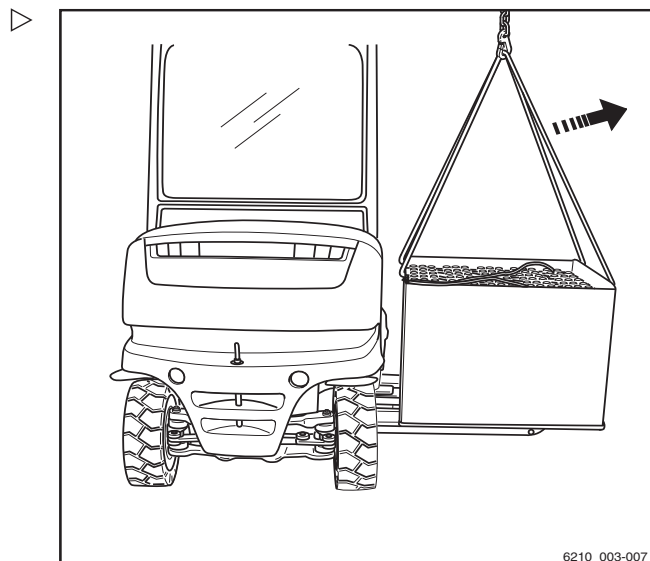

Maintenance

5

1000-hour maintenance/yearly maintenance

- Remove any dirt from the catch rails.
- Lubricate the catch rails with oil according to the maintenance data table - do not use grease!
- Connect the battery male connector.
- Pull the emergency off switch.
- Switch on the key switch.
- Retract the battery carrier fully and then extend again.

⚠ WARNING

Risk of crushing!

The support rollers must be swung out fully and locked in position after lubrication.

- Check that the support rollers are swung all the way out and are locked in position.
- If the support rollers are fully swung out and locked, reinstall the battery.
- If the support rollers do not swing out correctly or are not in the locked position, inform your authorised service centre.

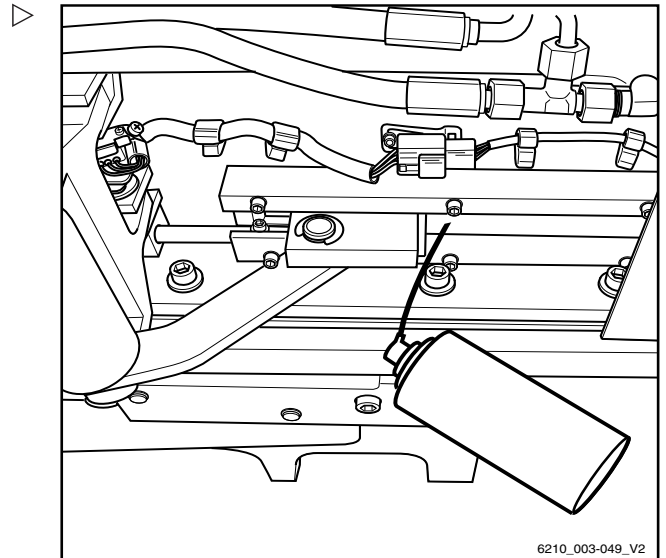

6210_003-049_V2

Checking the lift cylinders and connections for leaks

⚠ WARNING

Risk of injury!

Observe safety regulations for working on the lift mast, see the "Working at the front of the truck" chapter.

- Check hydraulic connections and lift cylinders for leaks (visual inspection).
- Have leaking screw joints or leaking hydraulic cylinders repaired by the authorised service centre.

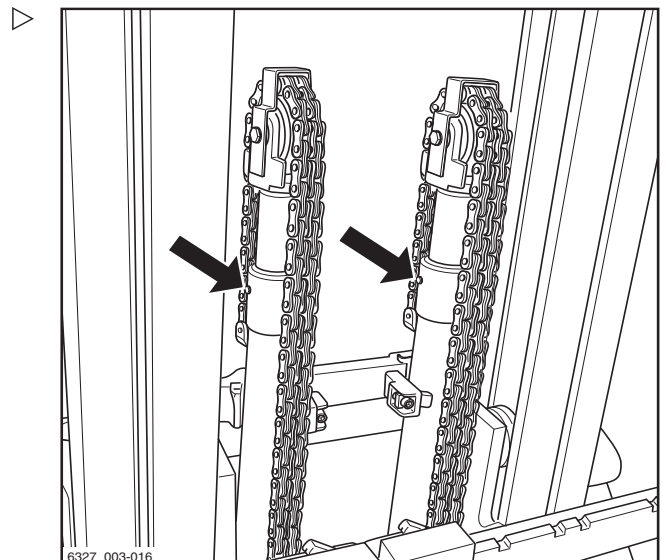

6327_003-016

5 Maintenance

1000-hour maintenance/yearly maintenance

Checking fork arms

- Inspect the fork arms (1) for any visible deformation. The wear must not amount to more than 10 % of the original thickness.

CAUTION

Worn fork arms should always be replaced in pairs.

- Check the securing mechanism (3) for proper operation.
- The locking screw (2) that prevents dislodging must be present.

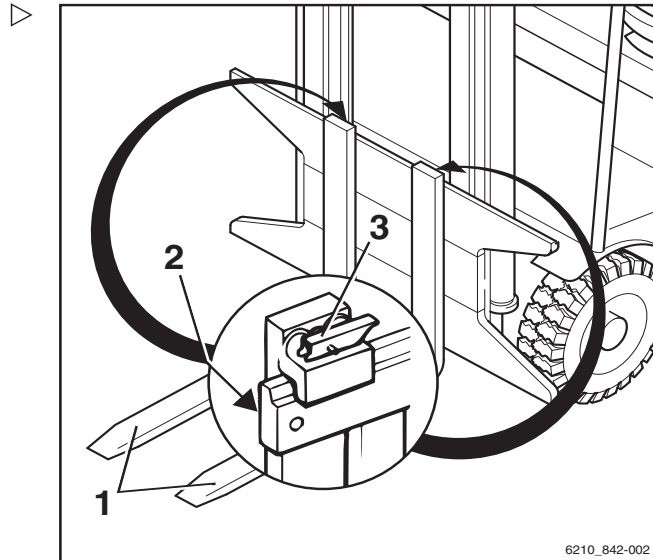

Checking the reversible fork arms

NOTE

This check is only required for reversible fork arms (variant).

- Check the outside of the fork bend (1) for cracks. Contact your service centre.

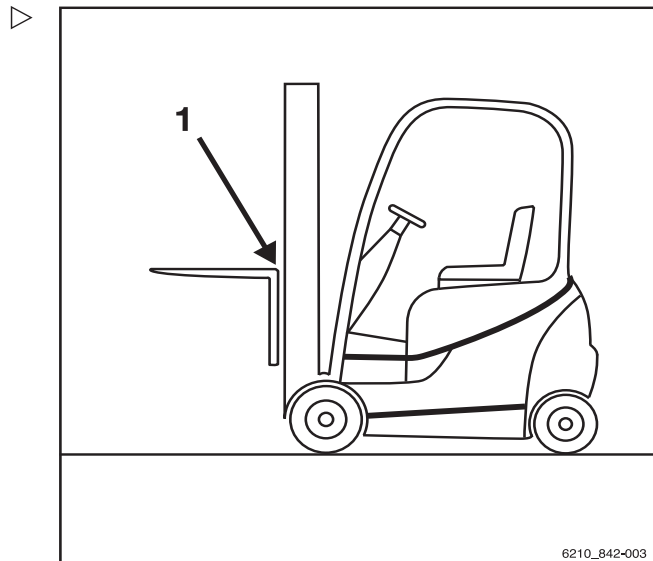

Checking the double pedal

- Remove the floorplate.
- Check that the support and springs of the double pedal mechanism are securely positioned.
- Check that all screws are sealed with locking varnish.

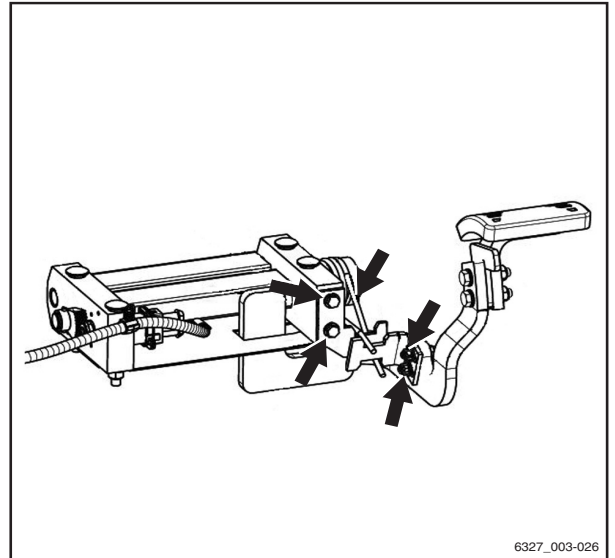

6327_003-026

Checking the battery changeover frame

- The screw joints and welded seams of the battery changeover frame must be subjected to a visual inspection.



5

Maintenance

1000-hour maintenance/yearly maintenance



6

Technical data

6 Technical data

Dimensions

Dimensions

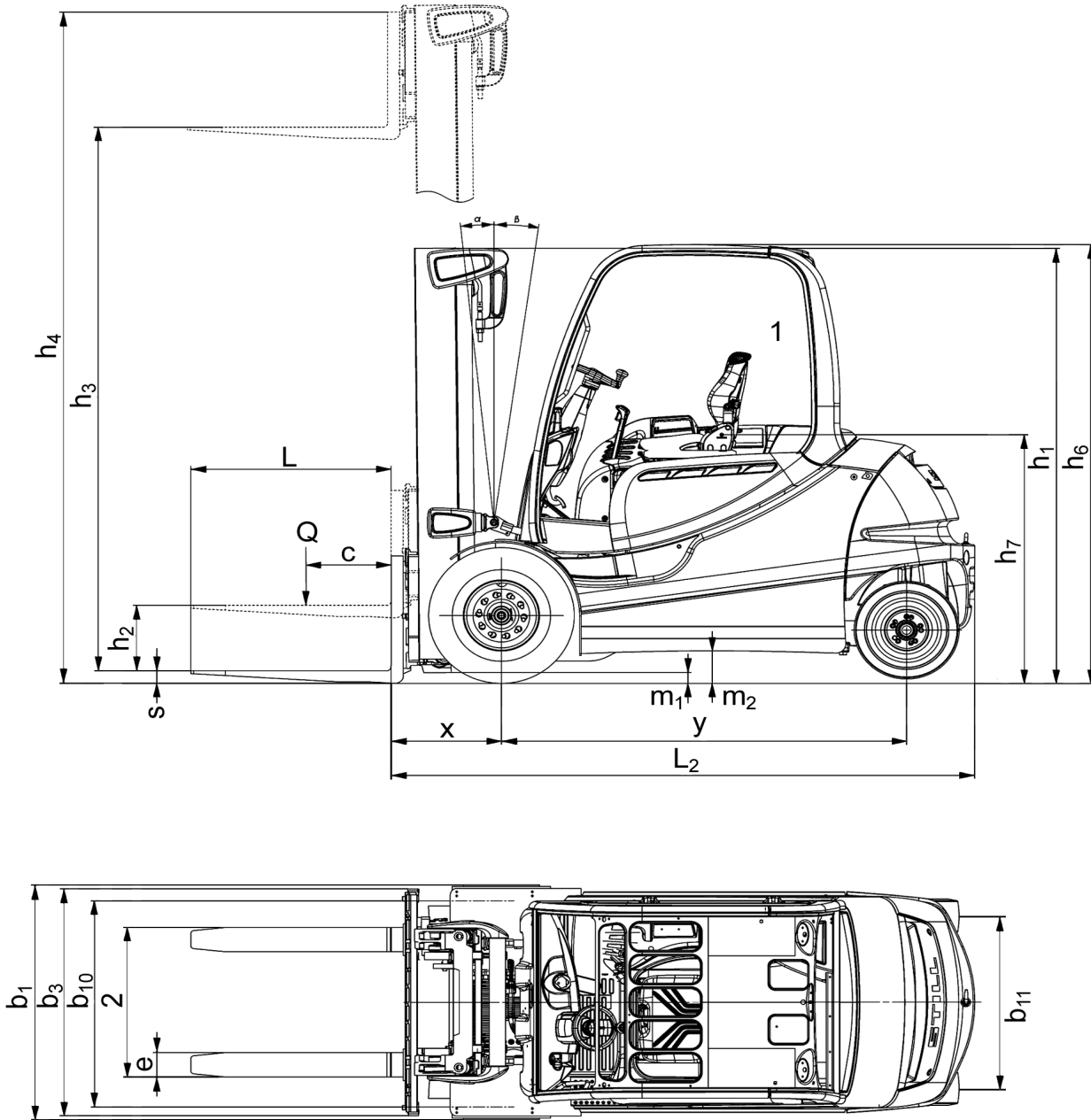

6327_003-028_V5

1 Seat is adjustable ± 90 mm

2 Fork spacing is adjustable

i NOTE

Measurements h_1 , h_3 , h_4 , h_6 and b_1 are customer-specific and can be taken from the order confirmation.



Technical data

6

Dimensions

Centre of gravity "S" (distance measured from the front axle)

RX60-35/600	(6367)	945 mm
RX60-40	(6327)	945 mm
RX60-40/600	(6368)	945 mm
RX60-45	(6328)	985.5 mm
RX60-45/600	(6369)	985.5 mm
RX60-50	(6329)	1023 mm
RX60-50/600	(6330)	1023 mm

 **NOTE**

The specified centre of gravity "S" relates to trucks with standard equipment. If, for example, the truck is equipped with a different lift mast, attachment or driver protection structure, this value is only a guide value. If necessary, the centre of gravity "S" must be determined on an individual basis for each truck.

VDI datasheet RX60-35/600

VDI datasheet RX60-35/600

i NOTE

This VDI datasheet specifies only the technical values for trucks with standard equipment. Different tyres, lift masts, additional units etc. can produce different values.

Key data

Model		RX60-35/600
Type number		6367
Manufacturer		STILL GmbH
Drive		Electric
Operation		Seat
Rated capacity/load	Q (kg)	3500
Load centre of gravity distance	c (mm)	600
Load distance	x (mm)	525
Wheelbase	y (mm)	2021

Weights

Model		RX60-35/600
Type number		6367
Net weight	kg	6495
Front axle load, laden	kg	8748
Rear axle load, laden	kg	1247
Front axle load, unladen	kg	3300
Rear axle load, unladen	kg	3195

Wheels, chassis frame

Model		RX60-35/600
Type number		6367
Tyres		SE
Tyre size, front		250/70-15



Technical data

6

VDI datasheet RX60-35/600

Model		RX60-35/600
Type number		6367
Tyre size, rear		200/75-9
Number of front wheels (x = driven)		2x
Number of rear wheels (x = driven)		2
Track width, front	b10 (mm)	1030
Track width, rear	b11 (mm)	920

Basic dimensions

Model		RX60-35/600
Type number		6367
Tilt of lift mast/fork carriage, forwards	Degrees	3
Tilt of lift mast/fork carriage, backwards	Degrees	9
Height with lift mast retracted	h1 (mm)	2300
Free lift	h2 (mm)	160
Lift ¹	h3 (mm)	2980
Height with lift mast extended	h4 (mm)	3762
Height above overhead guard (cab)	h6 (mm)	2322
Seat height in relation to SIP	h7 (mm)	1251
Coupling height	h10 (mm)	546 / 421
Overall length	l1 (mm)	4086
Length including fork back	l2 (mm)	2886
Overall width	b1 (mm)	1256
Fork arm thickness	s (mm)	50
Fork arm width	e (mm)	120
Fork arm length	l (mm)	1000
Fork carriage	Standard; class; form	ISO 2328 III A
Fork carriage width	b3 (mm)	1200
Ground clearance with load below lift mast	m1 (mm)	150
Ground clearance at the middle of the wheelbase	m2 (mm)	147

¹ The specified nominal lift takes into account the tyre deflection and tolerances of the tyre diameter.

VDI datasheet RX60-35/600

Model		RX60-35/600
Type number		6367
Aisle width for pallet 1000 x 1200 crosswise	Ast (mm)	4208
Aisle width for pallet 800 x 1200 lengthwise	Ast (mm)	4408 ²
Turning radius	Wa (mm)	2483
Smallest pivot point distance	b13 (mm)	629

Performance data

Model		RX60-35/600
Type number		6367
Driving speed with load	km/h	19
Driving speed without load	km/h	20
Lifting speed with load	m/s	0.43
Lifting speed without load	m/s	0.55
Lowering speed with load	m/s	0.55
Lowering speed without load	m/s	0.46
Pulling force with load	kg	3850
Pulling force without load	kg	4390
Max. tractive force with load	kg	16000
Max. tractive force without load	kg	16140
Climbing capability with load	%	11.9
Climbing capability without load	%	17.0
Max. climbing capability with load	%	16.9
Max. climbing capability without load	%	26.8
Acceleration time with load	s	5
Acceleration time without load	s	4.5
Service brake		Electr./mech.

Gradients

The values specified in the "Performance data" table as the maximum climbing capa-

² Calculated based on a 1000-mm-long fork arm

Technical data

6

VDI datasheet RX60-35/600

bility can be used only to compare the performance of forklift trucks in the same category. The specified values in no way represent the normal daily operating conditions.

⚠ WARNING

To use the truck safely – with or without a load – the maximum ascending or descending gradient permitted for travel is 15 %.

- If you have any questions, contact your authorised service centre.

Electric motor

Model		RX60-35/600
Type number		6367
Traction motor, power rating at S2: 60 min	kW	15
Lift motor, power rating at 15 % ED	kW	25
Battery	Standard; circuit	DIN 43536 A
Battery voltage	U (V)	80
Battery capacity K ₅	K ₅ Ah	840 (-930)
Battery weight	kg	2178
Energy consumption: 60 VDI working cycles/hour	kWh/h	9.7

Other

Model		RX60-35/600
Type number		6367
Working pressure for attachments	bar	250
Oil flow for attachments	l/min	30
Sound pressure level L _{pAZ} (driver's compartment) ³	dB (A)	< 70
Human vibration: acceleration according to EN 13059	m/s ²	< 0.7
Tow coupling, DIN type/model		Bolt

³ Without cab. Values are different with a cab.

VDI datasheet RX60-40 and RX60-40/600

VDI datasheet RX60-40 and RX60-40/600

i NOTE

This VDI datasheet specifies only the technical values for trucks with standard equipment. Different tyres, lift masts, additional units etc. can produce different values.

Key data

Model		RX60-40	RX60-40/600
Type number		6327	6368
Manufacturer		STILL GmbH	STILL GmbH
Drive		Electric	Electric
Operation		Seat	Seat
Rated capacity/load	Q (kg)	4000	4000
Load centre of gravity distance	c (mm)	500	600
Load distance	x (mm)	525	525
Wheelbase	y (mm)	2021	2021

Weights

Model		RX60-40	RX60-40/600
Type number		6327	6368
Net weight	kg	6477	6810
Front axle load, laden	kg	9296	9587
Rear axle load, laden	kg	1181	1223
Front axle load, unladen	kg	3286	3361
Rear axle load, unladen	kg	3209	3449

Wheels, chassis frame

Model		RX60-40	RX60-40/600
Type number		6327	6368
Tyres		SE	SE
Tyre size, front		250/70-15	355/50-15

Technical data

6

VDI datasheet RX60-40 and RX60-40/600

Model		RX60-40	RX60-40/600
Type number		6327	6368
Tyre size, rear		200/75-9	200/75-9
Number of front wheels (x = driven)		2x	2x
Number of rear wheels (x = driven)		2	2
Track width, front	b10 (mm)	1030	1104
Track width, rear	b11 (mm)	920	920

Basic dimensions

Model		RX60-40	RX60-40/600
Type number		6327	6368
Tilt of lift mast/fork carriage, forwards	Degrees	3	3
Tilt of lift mast/fork carriage, backwards	Degrees	9	9
Height with lift mast retracted	h1 (mm)	2300	2300
Free lift	h2 (mm)	160	160
Lift ⁴	h3 (mm)	2980	2980
Height with lift mast extended	h4 (mm)	3762	3987
Height above overhead guard (cab)	h6 (mm)	2322	2320
Seat height in relation to SIP	h7 (mm)	1251	1249
Coupling height	h10 (mm)	546 / 422	546 / 423
Overall length	l1 (mm)	3886	4086
Length including fork back	l2 (mm)	2886	2886
Overall width	b1 (mm)	1256	1399
Fork arm thickness	s (mm)	50	50
Fork arm width	e (mm)	120	120
Fork arm length	l (mm)	1000	1200
Fork carriage	Standard; class; form	ISO 2328 III A	ISO 2328 III A
Fork carriage width	b3 (mm)	1200	1200
Ground clearance with load below lift mast	m1 (mm)	150	150
Ground clearance at the middle of the wheelbase	m2 (mm)	147	145

⁴ The specified nominal lift takes into account the tyre deflection and tolerances of the tyre diameter.

VDI datasheet RX60-40 and RX60-40/600

Model		RX60-40	RX60-40/600
Type number		6327	6368
Aisle width for pallet 1000 x 1200 crosswise	Ast (mm)	4208	4208
Aisle width for pallet 800 x 1200 lengthwise	Ast (mm)	4408	4408 ⁵
Turning radius	Wa (mm)	2483	2483
Smallest pivot point distance	b13 (mm)	629	629

Performance data

Model		RX60-40	RX60-40/600
Type number		6327	6368
Driving speed with load	km/h	19	19
Driving speed without load	km/h	20	20
Lifting speed with load	m/s	0.40	0.38
Lifting speed without load	m/s	0.55	0.46
Lowering speed with load	m/s	0.55	0.55
Lowering speed without load	m/s	0.47	0.48
Pulling force with load	kg	3770	3700
Pulling force without load	kg	4390	4470
Max. tractive force with load	kg	15940	15900
Max. tractive force without load	kg	16140	16150
Climbing capability with load	%	11.3	10.6
Climbing capability without load	%	17.0	16.8
Max. climbing capability with load	%	15.5	15.5
Max. climbing capability without load	%	25.9	25.5
Acceleration time with load	s	5.1	5.1
Acceleration time without load	s	4.5	4.5
Service brake		Electr./mech.	Electr./mech.

Gradients

The values specified in the "Performance data" table as the maximum climbing capa-

⁵ Calculated based on a 1000-mm-long fork arm

Technical data

6

VDI datasheet RX60-40 and RX60-40/600

bility can be used only to compare the performance of forklift trucks in the same category. The specified values in no way represent the normal daily operating conditions.

⚠ WARNING

To use the truck safely – with or without a load – the maximum ascending or descending gradient permitted for travel is 15 %.

- If you have any questions, contact your authorised service centre.

Electric motor

Model		RX60-40	RX60-40/600
Type number		6327	6368
Traction motor, power rating at S2: 60 min	kW	15	15
Lift motor, power rating at 15 % ED	kW	25	25
Battery	Standard; circuit	DIN 43536 A	DIN 43536 A
Battery voltage	U (V)	80	80
Battery capacity K ₅	K ₅ (Ah)	840 (-930)	840 (-930)
Battery weight	kg	2178	2178
Energy consumption: 60 VDI working cycles/hour	kWh/h	10.2	10.3

Other

Model		RX60-40	RX60-40/600
Type number		6327	6368
Working pressure for attachments	bar	250	250
Oil flow for attachments	l/min	30	30
Sound pressure level L _{pAZ} (driver's compartment) ⁶	dB (A)	< 70	< 70
Human vibration: acceleration according to EN 13059	m/s ²	< 0.7	< 0.7
Tow coupling, DIN type/model		Bolt	Bolt

⁶ Without cab. Values are different with a cab.

VDI datasheet RX60-45 and RX60-45/600

VDI datasheet RX60-45 and RX60-45/600

i NOTE

This VDI datasheet specifies only the technical values for trucks with standard equipment. Different tyres, lift masts, additional units etc. can produce different values.

Key data

Model		RX60-45	RX60-45/600
Type number		6328	6369
Manufacturer		STILL GmbH	STILL GmbH
Drive		Electric	Electric
Operation		Seat	Seat
Rated capacity/load	Q (kg)	4500	4500
Load centre of gravity distance	c (mm)	500	600
Load distance	x (mm)	525	535
Wheelbase	y (mm)	2021	2021

Weights

Model		RX60-45	RX60-45/600
Type number		6328	6369
Net weight	kg	6793	7145
Front axle load, laden	kg	10112	10441
Rear axle load, laden	kg	1184	1204
Front axle load, unladen	kg	3329	3413
Rear axle load, unladen	kg	3463	3732

Wheels, chassis frame

Model		RX60-45	RX60-45/600
Type number		6328	6369
Tyres		SE	SE
Tyre size, front		355/50-15	355/50-15

Technical data

6

VDI datasheet RX60-45 and RX60-45/600

Model		RX60-45	RX60-45/600
Type number		6328	6369
Tyre size, rear		200/75-9	200/75-9
Number of front wheels (x = driven)		2x	2x
Number of rear wheels (x = driven)		2	2
Track width, front	b10 (mm)	1104	1104
Track width, rear	b11 (mm)	920	920

Basic dimensions

Model		RX60-45	RX60-45/600
Type number		6328	6369
Tilt of lift mast/fork carriage, forwards	Degrees	3	3
Tilt of lift mast/fork carriage, backwards	Degrees	9	9
Height with lift mast retracted	h1 (mm)	2300	2300
Free lift	h2 (mm)	160	160
Lift ⁷	h3 (mm)	2980	2980
Height with lift mast extended	h4 (mm)	3987	3987
Height above overhead guard (cab)	h6 (mm)	2320	2320
Seat height in relation to SIP	h7 (mm)	1249	1249
Coupling height	h10 (mm)	546 / 424	546 / 425
Overall length	l1 (mm)	3886	4096
Length including fork back	l2 (mm)	2886	2896
Overall width	b1 (mm)	1399	1399
Fork arm thickness	s (mm)	50	60
Fork arm width	e (mm)	120	130
Fork arm length	l (mm)	1200	1200
Fork carriage	Standard; class; form	ISO 2328 III A	ISO 2328 III A
Fork carriage width	b3 (mm)	1200	1310
Ground clearance with load below lift mast	m1 (mm)	150	150
Ground clearance at the middle of the wheelbase	m2 (mm)	145	145

⁷ The specified nominal lift takes into account the tyre deflection and tolerances of the tyre diameter.



VDI datasheet RX60-45 and RX60-45/600

Model		RX60-45	RX60-45/600
Type number		6328	6369
Aisle width for pallet 1000 x 1200 crosswise	Ast (mm)	4208	4218
Aisle width for pallet 800 x 1200 lengthwise	Ast (mm)	4408	4418 ⁸
Turning radius	Wa (mm)	2483	2483
Smallest pivot point distance	b13 (mm)	629	629

Performance data

Model		RX60-45	RX60-45/600
Type number		6328	6369
Driving speed with load	km/h	19	19
Driving speed without load	km/h	20	20
Lifting speed with load	m/s	0.38	0.38
Lifting speed without load	m/s	0.47	0.48
Lowering speed with load	m/s	0.55	0.55
Lowering speed without load	m/s	0.49	0.50
Pulling force with load	kg	3620	3610
Pulling force without load	kg	4470	4400
Max. tractive force with load	kg	15830	15750
Max. tractive force without load	kg	16150	16090
Climbing capability with load	%	9.5	9.2
Climbing capability without load	%	16.8	15.8
Max. climbing capability with load	%	14.3	14.3
Max. climbing capability without load	%	24.6	24.1
Acceleration time with load	s	5.2	5.2
Acceleration time without load	s	4.5	4.6
Service brake		Electr./mech.	Electr./mech.

Gradients

The values specified in the "Performance data" table as the maximum climbing capa-

⁸ Calculated based on a 1000-mm-long fork arm

Technical data

6

VDI datasheet RX60-45 and RX60-45/600

bility can be used only to compare the performance of forklift trucks in the same category. The specified values in no way represent the normal daily operating conditions.

⚠ WARNING

To use the truck safely – with or without a load – the maximum ascending or descending gradient permitted for travel is 15 %.

- If you have any questions, contact your authorised service centre.

Electric motor

Model		RX60-45	RX60-45/600
Type number		6328	6369
Traction motor, power rating at S2: 60 min	kW	15	15
Lift motor, power rating at 15 % ED	kW	25	25
Battery	Standard; circuit	DIN 43536 A	DIN 43536 A
Battery voltage	U (V)	80	80
Battery capacity K ₅	K ₅ (Ah)	840 (-930)	840 (-930)
Battery weight	kg	2178	2178
Energy consumption: 60 VDI working cycles/hour	kWh/h	10.8	11.1

Other

Model		RX60-45	RX60-45/600
Type number		6328	6369
Working pressure for attachments	bar	250	250
Oil flow for attachments	l/min	30	30
Sound pressure level L _{pAZ} (driver's compartment) ⁹	dB (A)	< 70	< 70
Human vibration: acceleration according to EN 13059	m/s ²	< 0.7	< 0.7
Tow coupling, DIN type/model		Bolt	Bolt

⁹ Without cab. Values are different with a cab.

VDI datasheet RX60-50 and RX60-50/600

VDI datasheet RX60-50 and RX60-50/600

i NOTE

This VDI datasheet specifies only the technical values for trucks with standard equipment. Different tyres, lift masts, additional units etc. can produce different values.

Key data

Model		RX60-50	RX60-50/600
Type number		6329	6330
Manufacturer		STILL GmbH	STILL GmbH
Drive		Electric	Electric
Operation		Seat	Seat
Rated capacity/load	Q (kg)	4990	4990
Load centre of gravity distance	c (mm)	500	600
Load distance	x (mm)	535	535
Wheelbase	y (mm)	2021	2088

Weights

Model		RX60-50	RX60-50/600
Type number		6329	6330
Net weight	kg	7121	7711
Front axle load, laden	kg	10917	11547
Rear axle load, laden	kg	1194	1154
Front axle load, unladen	kg	3372	3845
Rear axle load, unladen	kg	3749	3866

Wheels, chassis frame

Model		RX60-50	RX60-50/600
Type number		6329	6330
Tyres		SE	SE
Tyre size, front		355/50-15	355/50-15

Technical data

6

VDI datasheet RX60-50 and RX60-50/600

Model		RX60-50	RX60-50/600
Type number		6329	6330
Tyre size, rear		200/75-9	200/75-9
Number of front wheels (x = driven)		2x	2x
Number of rear wheels (x = driven)		2	2
Track width, front	b10 (mm)	1104	1104
Track width, rear	b11 (mm)	920	920

Basic dimensions

Model		RX60-50	RX60-50/600
Type number		6329	6330
Tilt of lift mast/fork carriage, forwards	Degrees	3	3
Tilt of lift mast/fork carriage, backwards	Degrees	9	6
Height with lift mast retracted	h1 (mm)	2300	2300
Free lift	h2 (mm)	160	160
Lift ¹⁰	h3 (mm)	2980	2780
Height with lift mast extended	h4 (mm)	3987	3935
Height above overhead guard (cab)	h6 (mm)	2320	2320
Seat height in relation to SIP	h7 (mm)	1249	1249
Coupling height	h10 (mm)	546 / 426	546 / 427
Overall length	l1 (mm)	3896	4163
Length including fork back	l2 (mm)	2896	2963
Overall width	b1 (mm)	1399	1399
Fork arm thickness	s (mm)	60	60
Fork arm width	e (mm)	130	130
Fork arm length	l (mm)	1000	1200
Fork carriage	Standard; class; form	ISO 2328 III A	ISO 2328 III A
Fork carriage width	b3 (mm)	1310	1310
Ground clearance with load below lift mast	m1 (mm)	150	150
Ground clearance at the middle of the wheelbase	m2 (mm)	145	145

¹⁰ The specified nominal lift takes into account the tyre deflection and tolerances of the tyre diameter.

VDI datasheet RX60-50 and RX60-50/600

Model		RX60-50	RX60-50/600
Type number		6329	6330
Aisle width for pallet 1000 x 1200 crosswise	Ast (mm)	4218	4284
Aisle width for pallet 800 x 1200 lengthwise	Ast (mm)	4418	4484 ¹¹
Turning radius	Wa (mm)	2483	2549
Smallest pivot point distance	b13 (mm)	629	638

Performance data

Model		RX60-50	RX60-50/600
Type number		6329	6330
Driving speed with load	km/h	19	18
Driving speed without load	km/h	20	19
Lifting speed with load	m/s	0.33	0.31
Lifting speed without load	m/s	0.46	0.44
Lowering speed with load	m/s	0.55	0.55
Lowering speed without load	m/s	0.51	0.52
Pulling force with load	kg	3600	3600
Pulling force without load	kg	4400	4400
Max. tractive force with load	kg	15670	15670
Max. tractive force without load	kg	16090	16090
Climbing capability with load	%	8.8	7.4
Climbing capability without load	%	15.8	13.7
Max. climbing capability with load	%	13.2	12.6
Max. climbing capability without load	%	23.4	21.4
Acceleration time with load	s	3.3	5.4
Acceleration time without load	s	4.6	4.7
Service brake		Electr./mech.	Electr./mech.

Gradients

The values specified in the "Performance data" table as the maximum climbing capa-

¹¹ Calculated based on a 1000-mm-long fork arm

Technical data

6

VDI datasheet RX60-50 and RX60-50/600

bility can be used only to compare the performance of forklift trucks in the same category. The specified values in no way represent the normal daily operating conditions.

⚠ WARNING

To use the truck safely – with or without a load – the maximum ascending or descending gradient permitted for travel is 15 %.

- If you have any questions, contact your authorised service centre.

Electric motor

Model		RX60-50	RX60-50/600
Type number		6329	6330
Traction motor, power rating at S2: 60 min	kW	15	15
Lift motor, power rating at 15 % ED	kW	25	25
Battery	Standard; circuit	DIN 43536 A	DIN 43536 A
Battery voltage	U (V)	80	80
Battery capacity K ₅	K ₅ (Ah)	840 (-930)	840 (-930)
Battery weight	kg	2178	2178
Energy consumption: 60 VDI working cycles/hour	kWh/h	11.5	12.1

Other

Model		RX60-50	RX60-50/600
Type number		6329	6330
Working pressure for attachments	bar	250	250
Oil flow for attachments	l/min	30	30
Sound pressure level L _{pAZ} (driver's compartment) ¹²	dB (A)	< 70	< 70
Human vibration: acceleration according to EN 13059	m/s ²	< 0.7	< 0.7
Tow coupling, DIN type/model		Bolt	Bolt

¹² Without cab. Values are different with a cab.

Ergonomic dimensions

Ergonomic dimensions

⚠ WARNING

Danger of impact injuries to the head!

If the head of the operator is located too close to the underside of the roof, the suspension of the driver's seat or an accident may cause the head to strike the overhead guard.

To avoid head injuries, a minimum distance of **40 mm** must be ensured between the underside of the roof and the head of the tallest operator.

To determine the actual head clearance, the operator must sit in the driver's seat and the seat suspension must be set to this driver's requirements.

Due to the individual nature of height and body weight as well as the wide variety of types of driver's seat and overhead guard, the minimum head clearance must be ensured in every truck.

The driver's compartment has been designed taking ergonomics in the workplace into account and in accordance with EN ISO 3411. In general, from the seat position, the operator has sufficient space to reach the operating devices safely, to operate the truck and to view the outline of the truck. Operators whose body size deviates from the specified dimensions on which EN ISO 3411 is based must be individually considered by the operating company.

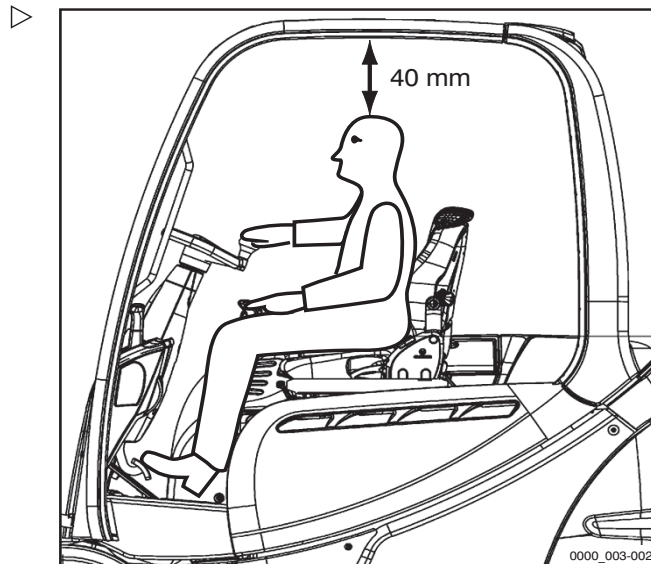

Information about the lead-acid battery

⚠ CAUTION

The battery weight and the battery dimensions affect the stability of the truck.

When replacing the battery, the weight ratios must not be changed. The battery weight must remain within the weight range specified on the nameplate. The location of ballast weights must not be changed. The bottom of the battery tray must be closed.

- Use batteries that meet DIN standards.
- Do not change the position of ballast weights.
- Check the battery weight against the information on the nameplate.
- Only use a battery tray that is closed at the bottom.

i NOTE

Battery specifications according to DIN 43535; cells in accordance with DIN EN 60254-2, 80-V circuit A.

- The battery weight can be found on the nameplate of the battery.

RX60-40 (6327), RX60-45 (6328), RX60-50 (6329), RX60-50/600 (6330), RX60-35/600 (6367), RX60-40/600 (6368), RX60-45/600 (6369)

Battery designation	Capacity [Ah]	Battery compartment dimensions [mm]			Tray
		Depth	Width	Height	
5 PzV 600	600	1028	855	784	235
5 PzW 700 HAWKER® wf 200plus	700				
5 PzS 700	700				
5 PzS 775	775				
5 CSM 800	800				
TENSOR® TCSM 1620	840				

Information about the lead-acid battery

Battery designation	Capacity [Ah]	Battery compartment dimensions [mm]			Tray
		Depth	Width	Height	
6 PzV 720	720	1028	999	784	236
6 PzW 840 HAWKER® wf 200plus	840				
6 PzS 840	840				
6 PzS 930	930				
6 CSM 960	960				

i NOTE

When converting to TENSOR® batteries, the maximum speed of the truck must be limited to 17 km/h for technical reasons. Contact the authorised service centre regarding this matter.

Information about the lithium-ion battery

⚠ CAUTION

The battery weight and the battery dimensions affect the stability of the truck.

When replacing the battery, the weight ratios must not be changed. The battery weight must remain within the weight range specified on the nameplate. The bottom of the battery tray must be closed.

i NOTE

Even though this truck has an operating voltage of 80 V, lithium-ion batteries with a nominal voltage of 90 V can be used.

- Use batteries that meet DIN standards.
- Check the battery weight against the information on the nameplate.
- Only use a battery tray that is closed at the bottom.
- The battery weight can be found on the nameplate of the battery.
- For more information, please refer to the nameplate and the operating instructions for the lithium-ion battery.

GG5 Li-Ion 90 V BG7

Battery designation and nominal energy [kW/h]	Capacity [Ah]	Battery compartment dimensions [mm]			Weight [kg]	Tray
		Depth	Width	Height		
36.2	402	1028	720	999	2178	S509
118.44	1316					

- Contact the authorised service centre for further technical data.

6

Technical data

Fuse assignment

Fuse assignment

Fuse assignment standard equipment

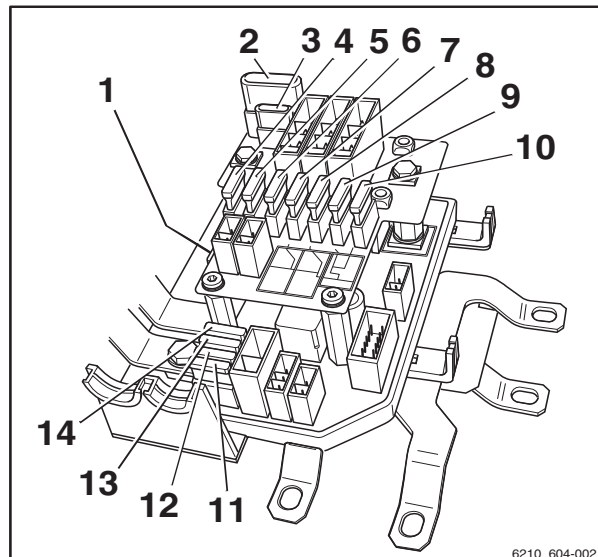

1	Main fuse	F01	400 A
2	Heating system	F22	50 A
3	Voltage converter	F21	20 A
4	CPP rear	F24	10 A
5	Option board, solenoid valve on the attachment	F23	10 A
6	CPP/RPP roof	F26	25 A
7	CPP/RPP seat	F27	25 A
8	MMS option board	F29	15 A
9	CPP/RPP front	F28	10 A
10	Proportional technology	F25	10 A
11	U4 voltage converter	F15	10 A
	Solenoid valve on attachment	F15	10 A
12	U1 voltage converter	F14	15 A
	U1/U2 voltage converter	F14	30 A
	48 V working spotlight	F14	15 A
13	SU/MCU	F11	10 A
14	Horn	F12	10 A

Fuse assignment equipment variants

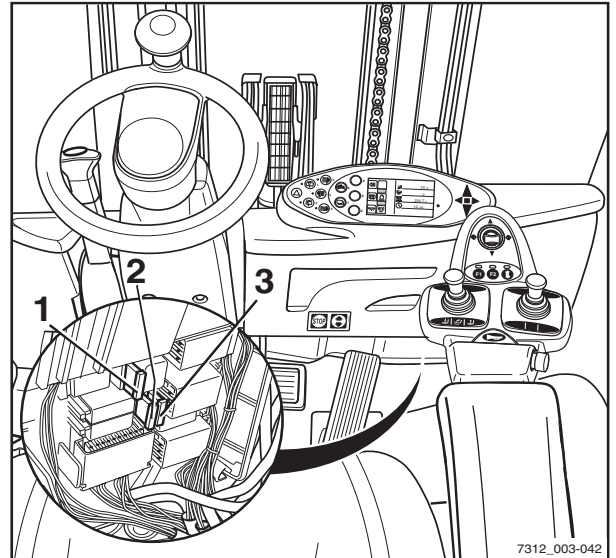

7312_003-042

1	5th hydraulic function 24/48 V	F1	10 A
2	Variant (e.g. MMS)	F3	10 A
3	Variant (e.g. light)	F2	10 A



6

Fuse assignment

Technical data



Index

A

Access authorisation	
Changing the password	106
Defining the driver PIN	102
Entering the access code	101
Selecting the driver PIN	104
Access authorisation with PIN code	99
Accessories	7
Actuate the parking brake	
when the truck is moving	148
Actuating the drive direction switch	
Fingertip version	135
Joystick 4Plus version	135
Mini-console version	136
Mini-lever version	134
Multiple-lever version	134
Address of manufacturer	I
Adjusting the armrest	85
Adjusting the fork	190
Adjusting the steering column	86
After cleaning	358
Attachments	
Assembly	202
Controlling using a double mini-lever	213
Controlling using multi-lever operation	210
Controlling using the double mini-lever and the 5th function	215
Controlling using the joystick 4Plus	225
Controlling using the quadruple mini-lever and the 5th function	223
Controlling using the triple mini-lever and the 5th function	219
Controlling with a quadruple mini-lever	221
Controlling with a triple mini-lever	217
Controlling with fingertip	229
Controlling with fingertip and 5th function	230
General controlling	208
Mounting	203
Operating with multi-lever controls and the 5th function	211
Releasing the pressure from the connections	204
Special risks	42
Taking up a load	236
Automatic lift cut out	178
Automatic tow coupling	264
Coupling RO*243	266
Coupling RO*244 A	268
Coupling RO*245	270
Coupling RO*841	271
Uncoupling RO*243	267
Uncoupling RO*244 A	269
Uncoupling RO*245	271
Uncoupling RO*841	272
Axle stub nuts	
Checking the tightening torque	399



B	
Battery	
Changing the battery type	334
Charging	311
Charging to equalise	318
Charging with the battery charging flap	314
Check interlock	392
Checking	400
Checking condition, acid level and acid density	310
Checking the changeover frame	417
Checking the charge state	311
Disposal	23
Information	439
Maintaining	308
Safety regulations	305
Battery acid	52
Battery cover	
Check interlock	392
Battery specifications	
Lead-acid battery	439
Lithium-ion battery	441
Before taking up load	185
Blue-Q	
Configure	123
Functional description	121
Switching off	122
Switching off additional consumers	122
Switching on	122
C	
Cab	
Open door	253
Opening the side windows	254
Operating the interior lighting	255
Operating the rear window heating	256
CE labelling	5
Ceiling sensor	247
Changes to the truck	33
Changing the drive direction	137
Dual-pedal version	140
Changing the fork arms	171
Changing the password	106
Charging the lithium-ion battery	331
Checking fork arms	416
Checking the cable connections	411
Checking the charge state of the lead-acid battery	311
Checking the charge state of the lithium-ion battery	328
Checking the double pedal	417
Checking the driver's seat	395
Checking the emergency off function	94
Checking the lift cylinders and connections for leaks	415
Checking wheel fastenings	397
Clamp locking mechanism	
Releasing	232
Cleaning the electrical system	357
Cleaning the truck	355
Cleaning the windows	358
Climbing into the truck	77
Climbing out of the truck	77
Clipboard	260
Closing the cab door	254
Closing the side windows	254
Cold store application	274
Batteries	275
Operation	274
Types of application	274
Commissioning	11
Condition of the roadways	129
Connecting the battery male connector	303
Consumables	50
Disposal	53
Safety information for handling battery acid	52
Safety information for handling oils	50
Safety information for hydraulic fluid	51
Contact details	I
Copyright and trademark rights	18
Coupling pin in the counterweight	262



Index

Cover sheet on the counterweight		Display symbols	113
Fitting	391	Auxiliary equipment softkey	
Removing	391	functions	115
Crane loading	362	Error messages	114
Determining the loading weight	363	Menu navigation softkey functions	116
Hooking on the lifting straps	363	Numeric keypad	117
Curve Speed Control	158	Operating messages	113
D		Status LEDs	116
Damage	37	Warning messages	114
Danger area	190	Display-operating unit	
Danger areas of lithium-ion batteries	31	Standard display elements	99
Danger to employees	47	Disposal	
Declaration of conformity	6	Battery	23
Declaring the use of lithium-ion batteries	32	Components	23
Decommissioning the truck	366	Documentation scope	16
Defects	37	Double mini-lever	66
Defining the driver PIN	102	Lifting/lowering the fork carriage	165
Definition of directions	21	Tilting the lift mast	165
Description of the truck	2	Drive direction	
Dimensions	420	Neutral position	133
Dimensions of roadways	127	Driver qualification for using lithium-ion	
Disconnecting the battery male		batteries	32
connector	304	Driver rights, duties and rules of	
Display and operating unit		behaviour	27
Additional indicators	111	Driver's cab	
Adjusting the displays	111	Use	89
Configure Blue Q	123	Drivers	27
Indicators	109	Driveways	127
Display messages		Driving	
Display content	277	Ascending gradients	199
Drive-specific	291, 325	Descending gradients	199
General	282	Driving lights	
Display operating unit	62	Switching on and off	237
Resetting the daily kilometres	118	Driving on lifts	200
Setting the date	118	Driving on loading bridges	201
Setting the language	119	E	
Setting the time	118	EC declaration of conformity in	
Standard displays	109	accordance with Machinery	
		Directive	6
		Electric parking brake	
		Emergency operation	299
		Malfunctions	150



Emergencies	
Emergency operation of the electric parking brake	299
Truck tipping over	296
Using the emergency hammer	297
Emergency hammer	297
Emergency lowering	297
Emergency shutdown	295
Emissions	54
Battery	56
Noise emissions	54
Radiation	56
Vibrations	55
Entering the access code	101
Ergonomic dimensions	438
Error code table	277
Example	186
F	
Filling the washer system	245
Fingertip	70
Lifting/lowering the fork carriage	170
Tilting the lift mast	170
First-aid measures for working with lithium-ion batteries	
Maintenance personnel	321
Fitting attachments	202
FleetManager	246
Shock recognition	246
Fork arms	
Length	39
Fork extension	173
Four-way mini-lever	68
Lifting/lowering the fork carriage	167
Function checking	74
Fuse assignment	
Equipment variants	443
Standard equipment	442
Fuse box	
Closing	391
Opening	391
Fuses	
Checking	400
Replacing	402
G	
General	4
General view	58
Driver's compartment	60
H	
Handling gas springs and accumulators	39
Hazard areas	130
Hazard assessment	32
Hazard warning system	239
Hazards and countermeasures	44
Heating system	257
Hydraulic battery carrier	
Checking the oil level	411
Lubricating the slide elements	413
Oiling the catch rails	413
Hydraulic blocking function	177
Releasing	178
Hydraulic fluid	51
Hydraulic system	
Checking for leak tightness	405
Checking the oil level	404
I	
Illustration of lithium-ion batteries	324
Impermissible use	13
Information for carrying out maintenance	376
Maintenance timeframe	377
Information symbols	18
Insulation testing	48
Drive battery test values	49
Test values for the truck	49
Insurance cover on company premises	29
Interior lighting	255
Issue date of the operating instructions	18



Index

J

Jacking up	373
Joystick 4Plus	69
Fork-carriage sideshift	169
Lifting/lowering the fork carriage	168
Tilting the lift mast	169

L

Labelling points	8
Lashing	362
Lift cut out	
Automatic	178
Lift mast	
Lubricating the roller track	406
Removing	375
Securing against falling off	375
Securing against tilting backwards	374
Lift mast versions	
Triplex lift mast	163
Lift mast vertical position	179
Automatic approach	181
Calibrating	183
Description	179
Display	181
Possible restrictions	183
Run-in to end stops	181
Tilting the lift mast backwards	182
Tilting the lift mast forwards	182
Lifting	373
Lifting system	
Controlling using a double mini-lever	165
Controlling using a quadruple mini-lever	167
Controlling using a triple mini-lever	166
Controlling using the joystick 4Plus	168
Controlling with the fingertip console	170
Multi-lever	164
Operating devices	163

Lighting

STILL SafetyLight	244
Switching on and off	237
List of abbreviations	19
Lithium-ion batteries	
Battery weight and dimensions	323
Changing the battery type	334
Charging	331
Checking the charge state	328
Danger areas	31
Declaring the use of	32
Display	63
Display messages	325
Driver qualification	32
Fire protection measures	322
First-aid measures	321
Hazard assessment	32
Illustration	324
Information	441
Installing	337
Maintenance personnel	321
Nameplate	11
Permissible batteries	32
Procedure in the event of a fire	32
Product-specific dangers	31
Regulations for storing	325
Safety regulations	321, 323
Special features	30
Transporting outside the premises	33
Lithium-ion battery display	63
Load	
Picking up	192
Setting down	197
transporting	196
Load capacity	185
Load chains	
Cleaning	357
Load measurement	186
Description	186
Execution	187
Zero adjustment	95
Lubricating the joints and controls	392



M		Message	
Maintaining the heater	409	! PARKING BRAKE OIL PRES- SURE	291
Maintenance data table	387	? VERTICAL POSITION	286
Battery	387	ACCELERATOR	283
Controls/joints	387	APPLY HANDBRAKE	282
Drive axle	388	ARE YOU SURE ?	288
Electrical system	387	BRAKE SENSOR	283
General lubrication points	387	CLOSE THE DOOR	292
Hydraulic battery carrier	388	CODE DENIED	283
Hydraulic system	387	EMERGENCY SWITCH	285
Lift mast	388	LEVER	292
Load chains	389	LIFT HEIGHT	292
Steering axle	388	LITHIUM BATTERY ERROR	325
Tyres	388	LITHIUM BATTERY RESTRIC- TION	325
Washer system	389	LITHIUM BATTERY TEMPERA- TURE	325
Maintenance personnel for batteries	376	LOWER FORKS	284
Maintenance work without special qualifications	376	MOT/GEN. TEMP.	291
Malfunctions during lifting mode	176	NOT VALID	291
Malfunctions in the electric parking brake	150	OVERHEATING	290, 292
Manual tow coupling		PARKING BRAKE ACTIVE	284
Coupling	262	PARKING BRAKE: APPLY HANDBRAKE!	284
Uncoupling	263	REFERENCE CYCLE	286
Medical equipment	38	RELEASE PARKING BRAKE	284
		SAFETY BELT	287
		SEAT SWITCH	288
		SERVICE BRAKE	282
		STEERING	285
		SURVEILLANCE	291
		SWITCH OFF TRUCK?	283
		TILTING SPEED	285
		Messages	
		General	282
		Mini console	71
		Misuse of safety systems	37



Index

MSG 65/MSG 75 driver's seat		Parking brake	142
Adjusting	78	Electric parking brake	144
Adjusting the backrest extension	81	Mechanical parking brake	142
Adjusting the lumbar support	81	Parking the truck securely	160
Adjusting the seat backrest	79	Permissible lithium-ion batteries	32
Adjusting the seat suspension	80	Personnel qualifications	376
Moving	79	Picking up loads	189
Switching the seat heater on and off	82	Place of use	13
Multi-lever	65	Procedure if truck tips over	296
Lifting/lowering the fork carriage	164	Procedure in the event of a fire when using lithium-ion batteries	32
Tilting the lift mast	164	Product-specific dangers of lithium-ion batteries	31
N		Production number	10
Nameplate	10	Prohibition of use by unauthorised persons	28
Nameplate of a lithium-ion battery	11	Proper usage	12
Neutral position	133	Push-up roof window	259
O		Q	
Oils	50	Quadruple mini-lever	
Opening the cab door	253	Tilting the lift mast	167
Opening the side windows	254	R	
Opening/closing the battery cover	334	Radio	256
Operating company	26	Rear window heating	256
Operating devices for hydraulic and traction functions	64	Reducing speed when turning	158
Operating materials		Reducing speed with a raised load	159
Quality and quantity	383	Regulations for storing lithium-ion batteries	325
Operating procedures	21	Replacing the battery	
Operating the service brake	141	General information	333
Operating the signal horn	88	Lithium-ion battery	337
Operational readiness		Using a change frame	341
Trucks for cold store application	409	using a forklift truck	338
Ordering spare parts and wearing parts	383	Using the hydraulic battery carrier	345
Overhead guard		Resetting the daily kilometres	118
Drilling	36	Resetting the daily operating hours	118
Roof loads	36	Residual dangers	41
Welding	36	Residual risks	41
Overview		Retrofitting	33
Accessories	7	Returning to service after decommis- sioning	368
P			
Packaging	23		



Reversible fork arm		Schematic views	21
Checking	416	Scope of the documentation	
Reversible fork arms	175	UPA solutions	17
Roadways	129 – 130	Seat belt	82
Aisle widths	127	Checking	394
Ascending gradients	128	Cleaning	395
Components protruding beyond the		Fastening	83
truck contour	129	Fastening on a steep slope	84
Descending gradients	128	Maintaining	394
Rotating beacon	238	Malfunction due to cold	84
Rules for roadways and the working		Releasing	84
area	130	Replacement after an accident	395
S		Selecting the drive direction	133
Safety devices	373	Selecting the driver PIN	104
Safety inspection	48	Set values	373
Safety regulations for handling		Setting chocks	361
lithium-ion batteries	321	Setting the date	118
Battery weight and dimensions	323	Setting the drive programs	130
Fire protection measures	322	Setting the language	119
Maintenance personnel	321	Setting the time	118
Safety regulations for handling the		Shock recognition	246
battery	305	Special risks	42
Battery weight and dimensions	307	Sprint mode (variant)	132
Damage to cables and battery male		Stability	42
connectors	308	Standard display elements	99
Fire protection measures	306	Starting drive mode	136
Maintenance personnel	305	Dual-pedal version	138
Performing battery maintenance	307	Status LEDs	116
Safety regulations for maintenance		Steering	157
General information	372	Steering axle	
Safety devices	373	Checking	398
Set values	373	Checking the lines for leaks	399
Working on the electrical equip-		Lubrication	398
ment	372	Servicing	398
Working on the hydraulic equip-		Steering system	
ment	372	Checking for correct function	93
Safety regulations for working on the lift		Storing the truck	366
mast	374	StVZO (Road Traffic Licensing	
Safety regulations for working with		Regulations) information	11
lithium-ion batteries	323	Switching off the truck	160
Safety regulations when driving	125	Switching on the key switch	97
Safety regulations when handing loads	184		



Index

T

Technical data	
Dimensions	420
The turn indicators	
Fingertip version	240
Mini-console version	241
Mini-lever version	239
Three-way mini-lever	67
Lifting/lowering the fork carriage	166
Topicality of the operating instructions	18
Towed load	261
Towing	300
Proper use	12
Trailers	
Towing	272
Transport	360
Transporting pallets	191
Transporting suspended loads	191
Transporting the battery by crane	
Lead-acid battery	353
Lithium-ion battery	354
Transporting the lithium-ion battery	33
Triple mini-lever	
Tilting the lift mast	166
Turn indicators	
Switching on and off	239
Types of lift mast	162
Telescopic mast	162
Tyres	
Safety principles	37

U

Unlocking the emergency off switch	87
Using working platforms	15

V

Valve cover	
Installing	390
Removing	390

Variant

Ceiling sensor	247
----------------	-----

Variants

Access authorisation with PIN code	99
Automatic lift cut out	178
Clamp locking mechanism	232
Clipboard	260
FleetManager	246
Fork extension	173
Heating system	257
Lift mast vertical position	179
Lifting systems	162
Load measurement	186
Push-up roof window	259
Radio	256
Reducing speed with a raised load	159
Reversible fork arms	175
Shock recognition	246
Sprint mode	132
Triplex lift mast	163
Wheel chock	161
Windscreen wiper/washer	245

VDI datasheet

RX60-35/600	422
RX60-40	426
RX60-40/600	426
RX60-45	430
RX60-45/600	430
RX60-50	434
RX60-50/600	434

Vertical lift mast position

Checking for correct function	95
View of functions and operations	21
View of operating procedures	21
Views of the display operating unit	22
Visual inspections	74

W

Warning regarding non-original parts	36
Wheel chock	161



Wheels and tyres

Checking the condition and wear of the tyres	396
Checking wheel fastenings	397
Maintaining	396
Windscreen wiper/washer	245
Working at the front of the truck	374
Working on the electrical equipment	372
Working on the hydraulic equipment	372
Working spotlight for reverse travel	
Switching on and off	238

Working spotlights

Automatically switching on/off	243
Lift-height-controlled switching on/off	243
Manually switching on/off	242
Switching on and off	237, 242

Z

Zero adjustment of the load measurement	95
---	----



