



Original instructions

Electric forklift truck

RX60-60
RX60-70
RX60-80
RX60-80/900



6341 6342 6343 6344
56358042501 EN - 10/2018

first in intralogistics



Preface

Address of manufacturer and contact details ▷

STILL GmbH
Berzeliusstraße 10
22113 Hamburg, Germany
Tel. +49 (0) 40 7339-0
Fax: +49 (0) 40 7339-1622
Email: info@still.de
Website: <http://www.still.de>



Rules for the operating company of industrial trucks

In addition to these operating instructions, a code of practice containing additional information for the operating companies of industrial trucks is also available.

This guide provides information for handling industrial trucks:

- Information on how to select suitable industrial trucks for a particular area of application
- Prerequisites for the safe operation of industrial trucks
- Information on the use of industrial trucks
- Information on transport, initial commissioning and storage of industrial trucks

Internet address and QR code ▷

The information can be accessed at any time by pasting the address <https://m.still.de/vdma> in a web browser or by scanning the QR code.

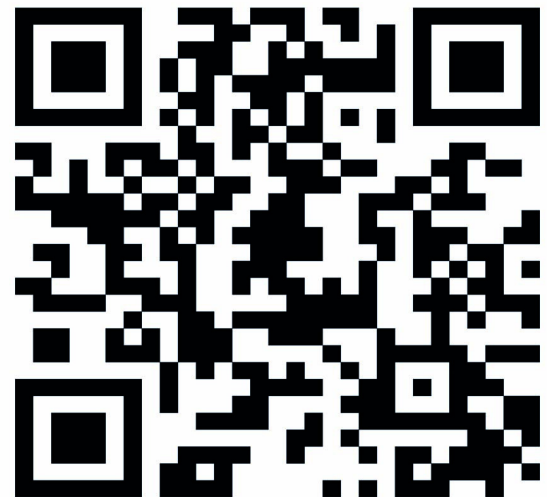





Table of contents

1 Foreword

Your truck	2
Description of the truck	2
General	4
CE labelling	5
EC declaration of conformity in accordance with Machinery Directive	6
Accessories	7
Overview	8
Nameplate	11
Production number	12
StVZO (Road Traffic Licensing Regulations) information	12
Using the truck	12
Commissioning	12
Proper usage	13
Proper use during towing	13
Impermissible use	14
Place of use	14
Parking in temperatures below -10°C	15
Using working platforms	16
Information about the documentation	17
Documentation scope	17
Supplementary documentation	18
Issue date and topicality of the operating instructions	19
Copyright and trademark rights	19
Explanation of information symbols used	19
List of abbreviations	20
Units	22
Definition of directions	23
Schematic views	23
Environmental considerations	25
Packaging	25
Disposal of components and batteries	25

2 Safety

Definition of responsible persons	28
Operating company	28
Specialist	28
Drivers	29
Basic principles for safe operation	31
Insurance cover on company premises	31



Table of contents

Changes and retrofitting	31
Changes to the overhead guard and roof loads	33
Warning regarding non-original parts	34
Damage, defects and misuse of safety systems	34
Tyres	35
Medical equipment	36
Exercise caution when handling gas springs and accumulators	37
Length of the fork arms	37
Residual risk	39
Residual dangers, residual risks	39
Special risks associated with using the truck and attachments	40
Overview of hazards and countermeasures	42
Danger to employees	45
Safety tests	46
Regular safety inspection of the truck	46
Insulation testing	46
Safety regulations for handling consumables	48
Permissible consumables	48
Oils	48
Hydraulic fluid	49
Battery acid	50
Coolant and cooling fluid	51
Disposal of consumables	52
Emissions	53
3 Overviews	
Overview	58
Driver's compartment	60
Operating and display elements	61
Display operating unit	61
Operating devices for hydraulic and driving functions	62
Double mini-lever	63
Three-way mini-lever	64
Four-way mini-lever	65
Joystick 4Plus	66
Fingertip	67
Mini console	68



Table of contents

4 Operation

Checks and tasks before daily use	70
Visual inspections	70
Climbing into and out of the truck	73
Shelves and cup holders	76
Adjusting the MSG 65/MSG 75 driver's seat	76
Adjusting the armrest	80
Adjusting the steering column	81
Unlocking the emergency off switch	82
Operating the signal horn	82
Seat belt	83
Using the driver's cab	86
Checking the brake system for correct function	86
Checking the steering system for correct function	89
Checking the emergency off function	90
Checking the vertical lift mast position (variant) for correct function	91
Zero adjustment of the load measurement (variant)	91
Switching on	93
Switching on the key switch	93
Access authorisation with PIN code (variant)	95
Operating the display and operating unit	105
Indicators	105
Adjusting the displays	107
Symbols in the display	109
Setting the date or time	114
Resetting the daily kilometres and daily operating hours	114
Setting the language	115
Softkeys for operating various equipment variants	115
Configuring Blue-Q efficiency mode	116
Blue-Q efficiency mode	118
Functional description	118
Switching off additional consumers	119
Switching efficiency mode Blue-Q on and off	119
Traction	121
Safety regulations when driving	121
Roadways	123
Setting the drive programme	125
Sprint mode (variant)	127
Selecting the drive direction	128
Actuating the drive direction switch, mini-lever version	129
Actuating the vertical rocker switch for the "drive direction", joystick 4Plus version	130



Table of contents

Actuate the drive direction switch, fingertip version	130
Actuating the drive direction switch, mini-console version	131
Starting drive mode	131
Starting drive mode, dual pedal version (variant)	134
Operating the service brake	137
Actuating the mechanical parking brake	138
Steering	140
Reducing speed when turning (Curve Speed Control)	141
Driving on ascending and descending gradients	142
Reducing speed with a raised load (variant)	143
Parking	144
Parking the truck securely and switching it off	144
Wheel chock (variant)	145
Lifting	146
Lifting system variants	146
Automatic lift cut out (variant)	146
Lift mast vertical position (variant)	147
Types of lift mast	151
Malfunctions during lifting mode	152
Hydraulic blocking function	153
Lifting system operating devices	154
Controlling the lifting system using a double mini-lever	155
Controlling the lifting system using a triple mini-lever	156
Controlling the lifting system using a quadruple mini-lever	157
Controlling the lifting system using the joystick 4Plus	158
Controlling the lifting system with the fingertip console	160
Changing the fork arms	161
Fork extension (variant)	163
Operation with reversible fork arms (variant)	165
Handling loads	167
Safety regulations when handling loads	167
Before taking up load	168
Load measurement (variant)	169
Picking up loads	172
Danger area	173
Transporting pallets	174
Transporting suspended loads	174
Load pick up	175
Transporting loads	179
Setting down loads	180
Driving on lifts	182



Table of contents

Driving on loading bridges	183
Attachments	184
Fitting attachments	184
Releasing the pressure from the hydraulic system	186
General instructions for controlling attachments	188
Controlling attachments using a double mini-lever	190
Controlling attachments using the double mini-lever and the 5th function	192
Controlling attachments using a triple mini-lever	194
Controlling attachments using the triple mini-lever and the 5th function	196
Controlling attachments using a quadruple mini-lever	198
Controlling attachments using the quadruple mini-lever and the 5th function	200
Controlling attachments via the joystick 4Plus	202
Controlling attachments using the joystick 4Plus and the 5th function	203
Controlling the attachments with fingertip	204
Controlling attachments with fingertip and the 5th function	205
Clamp locking mechanism (variant)	207
Taking up a load using attachments	210
Auxiliary equipment	211
Switching the lighting on and off	211
Switching the working spotlight for reverse travel on and off	212
Switching the rotating beacon on and off	213
Switching the hazard warning system on and off	213
Switching the turn indicators on and off	214
Switching the double working spotlights on and off.	216
STILL SafetyLight (variant)	218
Operating the windscreen wiper/washer	219
Filling the washer system	219
FleetManager (variant)	220
Shock recognition (variant)	220
12-V socket	221
Driver restraint systems (variants)	221
Ceiling sensor (variant)	222
Cab	228
Opening the cab door	228
Closing the cab door	229
Opening the side windows	229
Closing the side windows	229
Operating the interior lighting	230
Operating the rear window heating	231
Radio (variant)	231
Heating system (variant)	232



Table of contents

Push-up roof window (variant)	234
Clipboard (variant)	234
Trailer operation	235
Towed load	235
Coupling pin in the counterweight	236
Automatic tow coupling	238
Towing trailers	246
Display messages	247
Display content	247
Error code table	247
General messages	250
Drive-specific messages	259
Connecting and disconnecting the battery male connector	262
Connecting the battery male connector	262
Disconnecting the battery male connector	263
Handling the battery	265
Safety regulations when handling the battery	265
Checking the battery charge status	268
Charging the battery	268
Equalising charging to preserve the battery capacity	271
Replacing and transporting the battery	273
General information on replacing the battery	273
Changing to a different battery type	273
Opening and closing the battery cover	274
Replacing the battery	276
PowerPlusLife battery	282
PowerPlusLife® battery	282
PowerPlusLife® temperature monitoring	284
PowerPlusLife® error messages	284
Cleaning	286
Cleaning the truck	286
Cleaning the electrical system	288
Cleaning load chains	288
Cleaning the windows	289
After cleaning	289
Procedure in emergencies	291
Emergency shutdown	291
Procedure if truck tips over	293
Emergency hammer	294
Emergency lowering	294



Table of contents

Releasing the spring-operated brake	296
Towing	299
Transporting the truck	302
Transportation	302
Crane loading	304
Shutdown	308
Shutting down and storing the truck	308
Re-commissioning after shutdown	310
5 Maintenance	
Safety regulations for maintenance	312
General information	312
Working on the hydraulic equipment	312
Working on the electrical equipment	312
Safety devices	313
Set values	313
Lifting and jacking up	313
Working at the front of the truck	314
General maintenance information	316
Personnel qualifications	316
Information for carrying out maintenance	316
Maintenance - 1000 hours/annually	319
Maintenance - 3000 hours/every two years	322
Ordering spare parts and wearing parts	322
Quality and quantity of the required operating materials	322
Lubrication plan	324
Maintenance data table	325
Providing access to maintenance points	328
Removing and attaching the left side cover	328
Installing and removing the bottom plate	328
Opening/closing the front right cover	330
Removing and attaching the rear cover	331
Preserving operational readiness	332
Checking the coolant level	332
Topping up cooling fluid and checking coolant content	333
Cleaning the radiator and checking the radiator for leak tightness	336
Checking the battery condition, acid level and acid density	338
Changing the heating system fresh air filter	339
Lubricating the joints and controls	340
Maintaining the seat belt	341



Table of contents

Checking the driver's seat	342
Checking the door latch	343
Replacing the recirculated air filter for the heating system	343
Servicing wheels and tyres	344
Replacing the fuses	346
Checking the hydraulic oil level	348
Checking the hydraulic system for leak tightness	350
Lubricating the lift mast and roller track	351
Greasing the automatic tow coupling	351
6 1000-hour maintenance/annual maintenance	
Other tasks	356
Checking the lift cylinders and the hydraulic connections for leak tightness	356
Checking the fork arms	356
Checking the reversible fork arms	357
7 Technical data	
Dimensions	360
VDI datasheet	362
Ergonomic dimensions	366
Battery specifications	367
Fuse assignment	369



1

Foreword



Your truck

Your truck

Description of the truck

General

The electrically driven counterbalanced trucks from series RX60–60/70/80 have a load capacity of up to eight tonnes with a load centre of gravity of 900 mm. This means that the truck can reach a top speed of 17 km/h, which can be increased to 20 km/h thanks to sprint mode and PowerPlusLife battery.

The bend-resistant and warp-resistant lift mast enables safe load handling during indoor and outdoor use, even with heavy loads. In addition, the driver's compartment features the most up-to-date ergonomic design in order to support safety. The steering column and the driver's compartment are both offset to one side, enabling comfortable working and preventing fatigue.

The low centre of gravity of the truck provides stability, which is guaranteed if the truck is used according to its intended use.

The truck is equipped with a particularly long-life air-cooled battery. Thanks to the high battery capacity of 1240 Ah and battery replacement from the side, the truck is suitable for multi-shift use. In addition, the series supports all the functions of FleetManager4.x.

Brake system

The brake system of the truck comprises three different brakes:

- Service brake
- Regenerative brake
- Parking brake

The service brake is based on a wear-free, oil-immersed multi-disc brake. This multi-disc brake is used as the service brake for heavy braking or emergency braking with the brake pedal. In the normal working mode, the regenerative brake of the electric traction motor takes effect. The regenerative brake converts the acceleration energy of the truck into electrical energy. This causes the truck to decelerate as soon as the accelerator pedal



is released. Completely removing your foot from the accelerator pedal causes the truck to brake until it comes to a standstill. A parking brake ensures that the truck remains securely in place when parked.

Steering

The truck is equipped with a swing axle and has kickback-free, hydraulic rear-wheel steering. Stability is guaranteed when cornering thanks to speed limitation based on the steering angle. The simple handling of the truck is assisted by the agile steering axle.

Hydraulic system

The steering, the lift cylinders and the tilt cylinders of the lift mast are all supplied by the electrically driven hydraulic pump.

The directional control valve block with electrical proportional technology ensures extremely sensitive movements and safe handling of the load. The hydraulic functions can be parameterised individually by the authorised service centre.

Up to three hydraulic circuits can be used to activate attachments (variant). Depending on the equipment, a hydraulic accumulator is also available in the lifting circuit for the purpose of dampening pressure peaks in the hydraulic system.

Drive concept

The RX60 60–80 is driven by a maintenance-free 80-volt three-phase drive.

Power is supplied by a battery that is located at the side for ease of access. The optional cold store variant is available for operating the truck in temperatures down to -30°C .

The driver can help to influence the energy consumption and performance of the truck using the Blue-Q efficiency mode, which allows the required setting for each current application to be called up via the display-operating unit.



Your truck

Operating devices

The truck is characterised by an accessible operating concept. When purchasing the truck, a variety of operating devices and equipment variants are available:

- Double mini-lever
- Triple mini-lever
- Quadruple mini-lever
- Joystick 4Plus
- Fingertip switch
- Single pedal
- Dual pedal

Hands are always kept free for steering and for controlling the operational movements to allow efficient working. The forces that need to be applied for this purpose are reduced to a minimum thanks to the compact steering wheel.

Operational information, such as the fuel level or an indication that the Blue-Q energy-saving mode is enabled, is shown on the display-operating unit.

For drive mode, the truck features either single-pedal or dual-pedal operation. The accelerator pedal is used to accelerate and brake (regenerative brake) the truck. In emergency situations or when carrying heavy loads, the driver can also brake the truck using the service brake by pressing the brake pedal. In dual-pedal operation, the truck has one pedal for the "Forwards" drive direction and one pedal for the "Reverse" drive direction. Acceleration and braking behaviour can be individually selected from five different drive programmes.

General

The truck described in these operating instructions corresponds to the applicable standards and safety regulations.

If the truck is to be operated on public roads, it must conform to the existing national regulations for the country in which it is being used.

The driving permit must be obtained from the appropriate office.

The truck has been fitted with state-of-the-art technology. Following these operating instructions will allow the truck to be handled safely. By complying with the specifications in these operating instructions, the functionality and the approved features of the truck will be retained.

Get to know the technology, understand it and use it safely - these operating instructions provide the necessary information and help to avoid accidents and to keep the truck ready for operation beyond the warranty period.

Therefore:

- Before commissioning the truck, read the operating instructions and follow the instructions.
- Always follow all of the safety information contained in the operating instructions and on the truck.

CE labelling

The manufacturer uses CE labelling to indicate that the truck complies with the standards and regulations valid at the time of marketing. This is confirmed by the issued EC declaration of conformity. The CE labelling is attached to the nameplate.

An independent structural change or addition to the truck can compromise safety, thus invalidating the EC declaration of conformity.

The EC declaration of conformity must be carefully stored and made available to the responsible authorities.

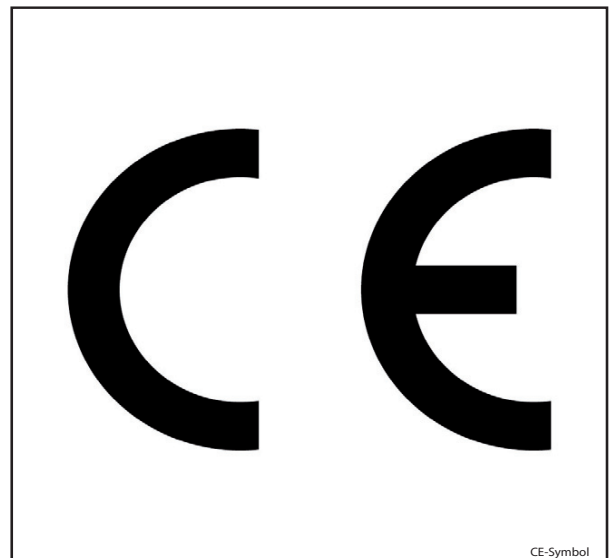



EC declaration of conformity in accordance with Machinery Directive

Declaration

STILL GmbH
Berzeliusstraße 10
D-22113 Hamburg Germany

We declare that the

Industrial truck	according to these operating instructions
Model	according to these operating instructions

conforms to the latest version of the Machinery Directive 2006/42/EC.

Personnel authorised to compile the technical documents:

See EC compliance declaration

STILL GmbH



Accessories

- Key for key switch (two pieces)
- Key for cab (variant)
- Hexagon socket wrench for emergency lowering



1 Foreword

Your truck

Overview

Labelling points, left

1

3

4

6

7

8

9

10

11

12

13

14

15

16



1	Decal information: Caution/Read the operating instructions/Fasten seat belt/Apply parking brake when leaving the truck/Passengers are not allowed/Do not jump off if the truck is tipping over/Lean in the opposite direction to which the truck is tipping	9	Decal information: StVZO (German Road Traffic Licensing Regulations) information (variant)
2	Manufacturer's label text	10	Decal information: Nameplate
3	Decal information: Capacity rating plate	11	Decal information: Inspection sticker
4	Decal information: Attachment capacity rating plate	12	Decal information: FEM test
5	Manufacturer's label text	13	Warning sign: Danger due to shearing/Danger due to high fluid pressure
6	Decal information: Hydraulic oil tank	14	Warning sign: Do not stand underneath the fork/Do not stand on the fork/Danger due to shearing/Danger due to high fluid pressure
7	Decal information: Tyre filling pressure	15	Warning sign: Actuate accumulator/brake pedal 30x/Read operating instructions
8	Warning sign: Do not stand underneath the fork/Do not stand on the fork	16	Decal information: Battery service

1 Foreword

Your truck

Labelling points, right

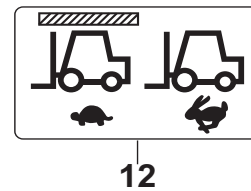
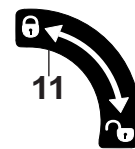
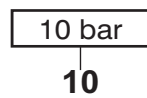
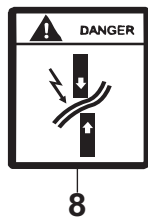
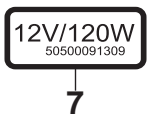
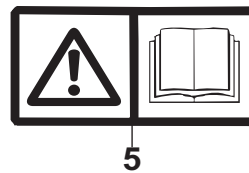
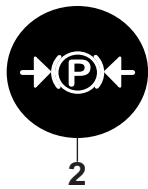
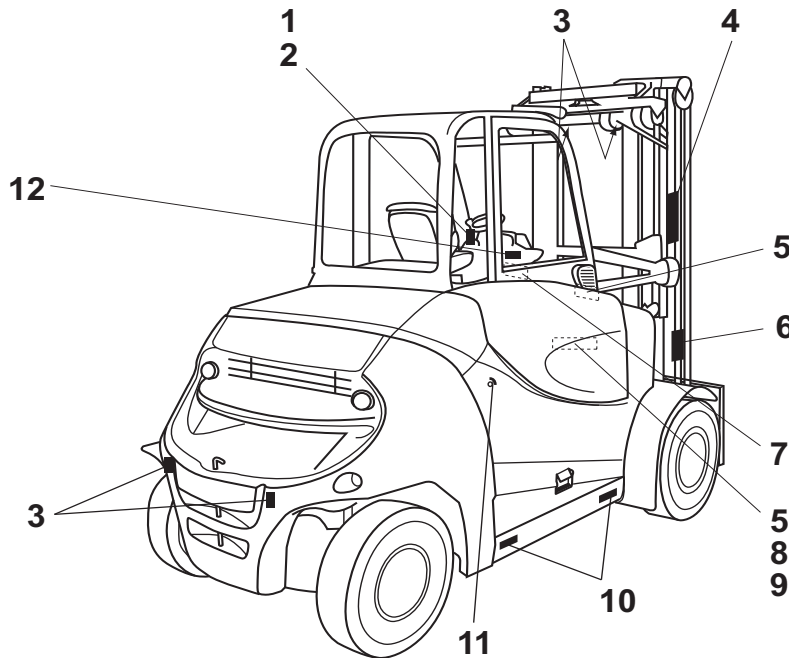

Foreword

1

Your truck

- | | | | |
|---|--|----|---|
| 1 | Decal information: Parking brake released | 7 | Decal information: 12-V socket |
| 2 | Decal information: Parking brake applied | 8 | Warning sign: Risk of short circuit due to shearing |
| 3 | Decal information: Lifting gear attachment point | 9 | Warning sign: Danger due to shearing |
| 4 | Manufacturer's label text | 10 | Decal information: Tyre filling pressure |
| 5 | Decal information: Caution/read the operating instructions | 11 | Decal information: To unlock, turn 90° to the right/to lock, turn 90° to the left |
| 6 | Warning sign: Danger due to shearing/Danger due to high fluid pressure | 12 | Decal information: Ceiling sensor |

Nameplate

The truck can be identified from the information on the nameplate.

The information for the battery weights (5, 6) and the ballast weight (7) only applies to electric forklift trucks.

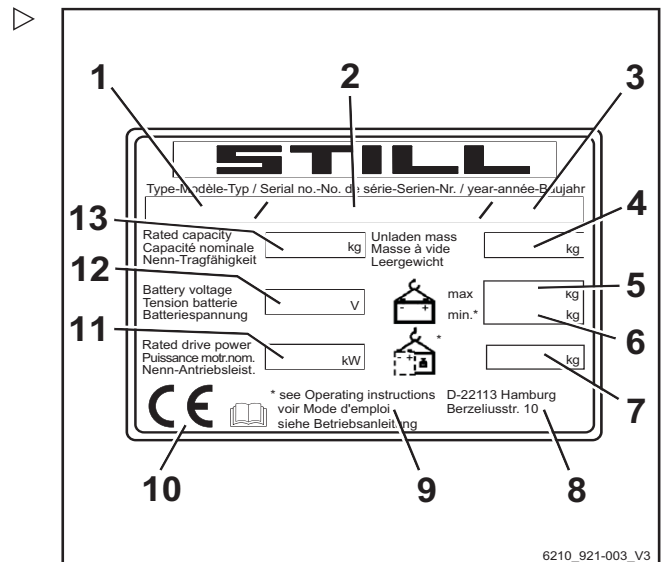

- | | |
|----|--|
| 1 | Type |
| 2 | Production number |
| 3 | Year of manufacture |
| 4 | Tare weight in kg |
| 5 | Max. permissible battery weight in kg |
| 6 | Min. permissible battery weight in kg |
| 7 | Ballast weight in kg |
| 8 | Address of manufacturer |
| 9 | Refer to the technical data listed in these operating instructions for more detailed information |
| 10 | CE labelling |
| 11 | Nominal drive power in kW |
| 12 | Battery voltage in V |
| 13 | Rated capacity in kg |

Using the truck

Production number

i NOTE

The production number is used to identify the truck. It can be found on the nameplate and must be referred to in all technical questions.

The production number contains the following coded information:

- (1) Production location
- (2) Model
- (3) Year of manufacture
- (4) Sequential number

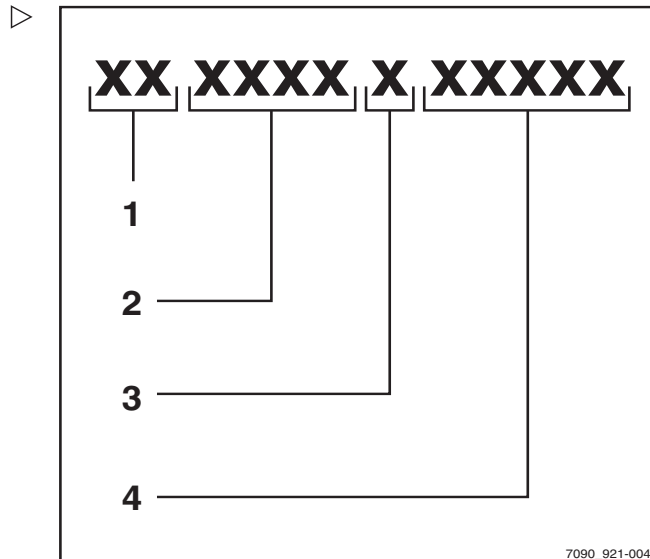

StVZO (Road Traffic Licensing Regulations) information

This label includes information on the weight and load distribution of the truck.

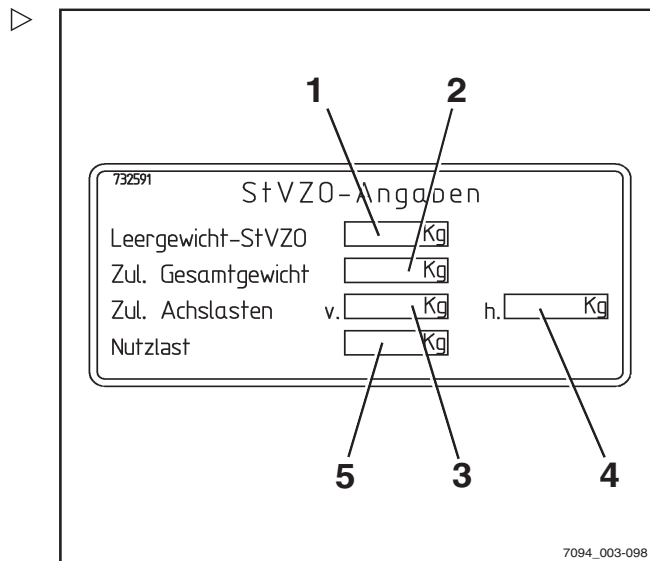

- 1 Tare weight (in kg)
- 2 Permitted total weight (in kg)
- 3 Permitted front axle weight (in kg)
- 4 Permitted rear axle weight (in kg)
- 5 Payload (in kg)

Using the truck

Commissioning

Commissioning is the initial intended use of the truck.



The necessary steps for the commissioning vary depending on the model and equipment of the truck. These steps require preparatory work and adjustment work that cannot be performed by the operating company. See also the chapter entitled "Definition of responsible persons".

- To commission the truck, contact the authorised service centre.

Proper usage

The truck described in these operating instructions is suitable for lifting, transporting and stacking loads.

The truck may only be used for its proper purpose as set out and described in these operating instructions.

If the truck is to be used for purposes other than those specified in the operating instructions, the approval of the manufacturer and, if applicable, the relevant regulatory authorities must be obtained beforehand to prevent hazards.

The maximum load to be lifted is specified on the capacity rating plate (load diagram) and must not be exceeded; see also the chapter entitled "Before picking up a load".

Proper use during towing

This truck is suitable for the occasional towing of trailers and is equipped with a towing device for this purpose. This occasional towing may not exceed 2% of the daily operating time. If the truck is to be used for towing on a more regular basis, the manufacturer should be consulted.

The regulations regarding trailer operation must be observed; see chapter "Trailer operation".

Using the truck

Impermissible use

The operating company or driver, and not the manufacturer, is liable for any hazards caused by improper use.

NOTE

Please observe the definition of the following responsible persons: "operating company" and "driver".

Use for purposes other than those described in these operating instructions is prohibited.



DANGER

There is a risk of fatal injury from falling off the truck while it is moving!

- It is prohibited to carry passengers on the truck.

The truck may not be operated in areas where there is a risk of fire, explosion or corrosion, or in areas that are particularly dusty.

Stacking or unstacking is not permissible on inclined surfaces or ramps.

Place of use

The truck can be used both outdoors and in buildings. Operation on public roads is only permitted if the "StVZO" (German Road Traffic Licensing Regulations) equipment variant is installed.

If the truck is to be operated on public roads, it must conform to the national regulations for the country in which it is being used.

The ground must have an adequate load capacity (concrete, asphalt) and a rough surface. Routes, work areas and aisle widths must conform to the specifications in these operating instructions, see the "Routes" chapter.

Driving on upward and downward gradients is permitted provided the specified data and specifications are observed, see the "Routes" chapter.

The truck is suitable for indoor and outdoor use in countries ranging from the Tropics to Nordic regions (temperature range: -20 °C to +40 °C).

This truck is not designed to be operated in cold stores.

⚠ CAUTION

Batteries may freeze!

If the truck is parked in an ambient temperature of below -10 °C for an extended period, the batteries will cool down. The electrolyte may freeze and damage the batteries. The truck will then not be ready for operation.

- When the ambient temperature is below -10 °C, only park the truck for short periods of time.

The operating company must ensure suitable fire protection for the relevant application in the truck's surroundings. Depending on the application, additional fire protection must be provided on the truck. If in doubt, contact the relevant authorities.

i NOTE

Please note the definition of "operating company" in the sense of responsible persons!

Parking in temperatures below -10°C

⚠ CAUTION

Batteries can freeze!

If the truck is parked in an ambient temperature below -10°C for an extended period, the batteries will cool down. The electrolyte may freeze and damage the batteries. The truck is then not ready for operation.

- When the ambient temperature is below -10°C, only park the truck for short periods of time.



Using the truck

Using working platforms

WARNING

The use of working platforms is regulated by national law. The use of working platforms is only permitted by virtue of the jurisdiction in the country of use.

- Observe national legislation.
- Before using working platforms, consult the national regulatory authorities.

Information about the documentation

Documentation scope

- Original operating instructions
- Original operating instructions for attachments (variant)
- Spare parts list
- Depending on the truck equipment, "UPA" operating instructions may also be provided

NOTE

Refer to the additional information in the section entitled "Rules for the operating company of industrial trucks".

These operating instructions describe all measures necessary for the safe operation and proper maintenance of the truck in all possible variants available at the time of printing. Special versions to meet customer requirements (UPA) are documented in separate operating instructions. If you have any questions, please contact your authorised service centre.

Enter the production number and year of manufacture from the nameplate in the space provided:

Production number:

Year of manufacture:

Please quote the production number in all technical enquiries.

Each truck comes with a set of operating instructions. These instructions must be stored carefully and must be available to the driver and operating company at all times. The storage location is specified in the chapter entitled "Overviews".

If the operating instructions are lost, the operating company must obtain a replacement from the manufacturer immediately.

The operating instructions are included in the spare parts list and can be reordered as a spare part.



Information about the documentation

The personnel responsible for operating and maintaining the equipment must be familiar with these operating instructions.

The operating company must ensure that all users have received, read and understood these operating instructions.

Safely store the complete documentation and pass on to the subsequent operating company when transferring or selling the truck.

NOTE

Please observe the definition of the following responsible persons: "operating company" and "driver".

Thank you for reading and complying with these operating instructions. If you have any questions or suggestions for improvements, or if you have found any errors, please contact the authorised service centre.

Supplementary documentation

This industrial truck can be fitted with un-planned equipment (UPA) that deviates from the standard equipment and/or the variants.

The UPA may be, for example:

- Special sensors
- Special attachments
- Towing devices
- Customised attachments

In this case, the industrial truck has additional documentation. This may be in the form of an insert or separate operating instructions.

The original operating instructions for this industrial truck are valid for the operation of standard equipment and variants without restriction. The operational and safety information in the original operating instructions continues to be valid in its entirety unless it is countermanded in this additional documentation.

The requirements for the qualification of personnel as well as the time for maintenance



may vary. This is defined in the additional documentation.

- If you have any questions, please contact your authorised service centre.

Issue date and topicality of the operating instructions

The issue date of these operating instructions can be found on the title page.

STILL is constantly engaged in the further development of trucks. These operating instructions are subject to change, and any claims based on the information and/or illustrations contained in them cannot be asserted.

Please contact your authorised service centre for technical support relating to your truck.

Copyright and trademark rights

These instructions must not be reproduced, translated or made accessible to third parties—including as excerpts—except with the express written approval of the manufacturer.

Explanation of information symbols used

DANGER

Indicates procedures that must be strictly adhered to in order to prevent the risk of fatalities.

WARNING

Indicates procedures that must be strictly adhered to in order to prevent the risk of injuries.

CAUTION

Indicates procedures that must be strictly adhered to in order to prevent material damage and/or destruction.

Information about the documentation

i NOTE

For technical requirements that require special attention.

♻️ ENVIRONMENT NOTE

To prevent environmental damage.

List of abbreviations

i NOTE

This list of abbreviations applies to all types of operating instructions. Not all of the abbreviations that are listed here will necessarily appear in these operating instructions.

Abbreviation	Meaning	Explanation
ABE	Display operating unit	
ArbSchG	Arbeitsschutzgesetz	German implementation of EU occupational health and safety directives
Betr-SichV	Betriebssicherheitsverordnung	German implementation of the EU working equipment directive
BG	Berufsgenossenschaft	German insurance company for the company and employees
BGG	Berufsgenossenschaftlicher Grundsatz	German principles and test specifications for occupational health and safety
BGR	Berufsgenossenschaftliche Regel	German rules and recommendations for occupational health and safety
DGUV	Berufsgenossenschaftliche Vorschrift	German accident prevention regulations
CE	Communauté Européenne	Confirms conformity with product-specific European directives (CE mark)
CEE	Commission on the Rules for the Approval of the Electrical Equipment	International commission on the rules for the approval of electrical equipment
DC	Direct Current	Direct current
DFÜ	Datenfernübertragung	Remote data transmission
DIN	Deutsches Institut für Normung	German standardisation organisation
EG	European Community	
EN	European standard	
FEM	Fédération Européenne de la Manutention	European Federation of Materials Handling and Storage Equipment
F _{max}	maximum Force	Maximum power



Abbreviation	Meaning	Explanation
GAA	Gewerbeaufsichtsamt	German authority for monitoring/issuing regulations for worker protection, environmental protection, and consumer protection
GPRS	General Packet Radio Service	Transfer of data packets in wireless networks
ID no.	ID number	
ISO	International Organization for Standardization	International standardisation organisation
LAN	Local Area Network	Local area network
K _{pA}	Uncertainty of measurement of sound pressure levels	
LED	Light Emitting Diode	Light emitting diode
L _p	Sound pressure level at the workplace	
L _{pAZ}	Average continuous sound pressure level in the driver's compartment	
LSP	Load centre of gravity	Distance of the centre of gravity of the load from the front face of the fork backs
MAK	Maximum workplace concentration	Maximum permissible air concentrations of a substance at the workplace
Max.	Maximum	Highest value of an amount
Min.	Minimum	Lowest value of an amount
PIN	Personal Identification Number	Personal identification number
PPE	Personal protective equipment	
SE	Super-Elastic	Superelastic tyres (solid rubber tyres)
SIT	Snap-In Tyre	Tyres for simplified assembly, without loose rim parts
StVZO	Straßenverkehrs-Zulassungs-Ordnung	German regulations for approval of vehicles on public roads
TRGS	Technische Regel für Gefahrstoffe	Ordinance on hazardous materials applicable in the Federal Republic of Germany
VDE	Verband der Elektrotechnik Elektronik Informationstechnik	German technical/scientific association
VDI	Verein Deutscher Ingenieure	German technical/scientific association
VDMA	Verband Deutscher Maschinen- und Anlagenbau e.V.	German Mechanical Engineering Industry Association
WLAN	Wireless LAN	Wireless local area network



Information about the documentation

Units

Unit symbol	Unit name	Explanation
°C	Degree Celsius	Unit of temperature
°F	Degree Fahrenheit	Unit of temperature
A	Ampere	Unit of electrical current
Ah	Ampere hour	Unit of electrical charge storage capacity (nominal capacity)
dB	Decibel	Unit of sound intensity
cm	Centimetre	Unit of length (1 cm = 10 mm)
cm ³	Cubic centimetres	Unit of volume
g	Gram	Unit of mass
h/d	Hours per day	Hours driven per day
kg	Kilogram	Unit of mass (1 kg = 1000 g)
kg/m ³	Kilograms per cubic metre	Unit of density (ratio of the mass of a body to its volume)
km/h	Kilometres per hour	Unit of speed
kN	Kilonewton	Unit of force (1 kN = 1000 N)
kW	Kilowatt	Unit of electrical power
kWh/h	Kilowatt hour/hour	Energy consumption
l	Litre	Unit of volume
l/h	Litres per hour	Unit of consumption
l/min	Litres per minute	Unit of consumption
m	Metre	Unit of length (1 m = 100 cm)
m/s ²	Metres per second squared	Unit of acceleration
min	Minute	Unit of time (1 min. = 60 s)
rpm	Revolution(s) per minute	Unit of revolution speed
mm	Millimetre	Unit of length (1 mm = 10 ⁻³ m)
N	Newton	Unit of force (1 N = 10 ⁻³ kN)
Nm	Newton metre	Unit of torque
s	Second	Base unit for time

Unit symbol	Unit name	Explanation
t	Tonne	Unit of mass (1 t = 1000 kg)
V	Volt	Unit of electrical voltage
W	Watt	Unit of electrical power
W/kg	Watt/kilogram	Performance by mass (power density)
Wh	Watt-hours	Unit of electrical work (nominal energy)
Wh/kg	Watt-hours/kilogram	Stored energy per kilogram of mass (energy density)

Definition of directions

The directions "forwards" (1), "backwards" (3), "right" (2) and "left" (4) refer to the installation position of the parts as seen from the driver's compartment; the load is to the front.

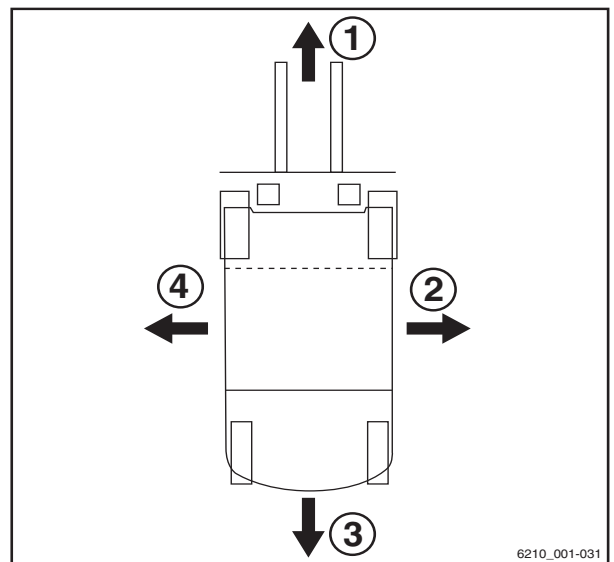

Schematic views

View of functions and operations

This documentation explains the (usually sequential) chain of certain functions or operations. Schematic diagrams of a counterbalance truck are used to illustrate these procedures.

NOTE

These schematic diagrams are not representative of the structural state of the documented truck. The diagrams are used solely for the purpose of clarifying procedures.

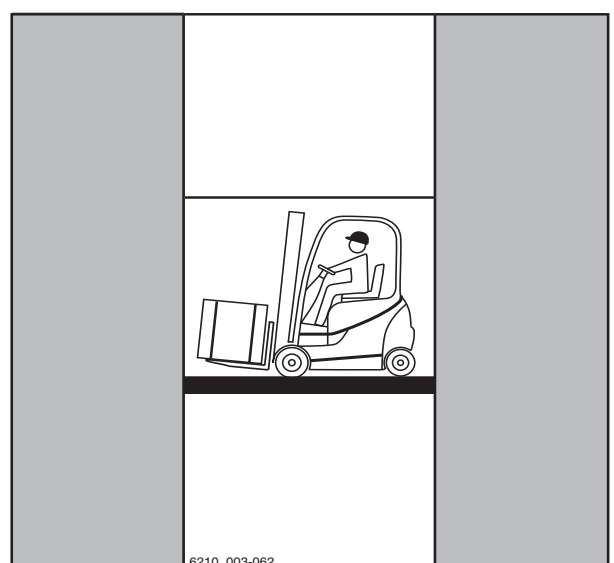

Information about the documentation

View of the display operating unit

i NOTE

Views of operating statuses and values in the display of the display operating unit are examples and partly dependent on the truck equipment. As a result, the displays shown of the actual operating statuses and values can vary. Information that is not relevant for descriptions is not shown.

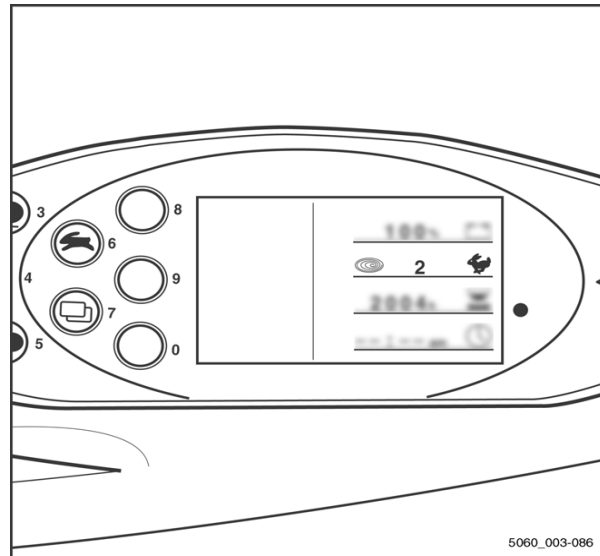



Environmental considerations

Packaging

During delivery of the truck, certain parts are packaged to provide protection during transport. This packaging must be removed completely prior to initial start-up.



ENVIRONMENT NOTE

The packaging material must be disposed of properly after delivery of the truck.

Disposal of components and batteries

The truck is composed of different materials. If components or batteries need to be replaced and disposed of, they must be:

- disposed of,
- treated or
- recycled in accordance with regional and national regulations.



NOTE

The documentation provided by the battery manufacturer must be observed when disposing of batteries.



ENVIRONMENT NOTE

We recommend working with a waste management company for disposal purposes.





2

Safety



Definition of responsible persons

Definition of responsible persons

Operating company

The operating company is the natural or legal person or group who operates the truck or on whose authority the truck is used.

The operating company must ensure that the truck is only used for its proper purpose and in compliance with the safety regulations set out in these operating instructions.

The operating company must ensure that all users read and understand the safety information.

The operating company is responsible for the scheduling and correct performance of regular safety checks.

We recommend that the national performance specifications are adhered to.

Specialist

A qualified person is defined as a service engineer or a person who fulfils the following requirements:

- A completed vocational qualification that demonstrably proves their professional expertise. This proof should consist of a vocational qualification or a similar document.
- Professional experience indicating that the qualified person has gained practical experience of industrial trucks over a proven period during their career. During this time, this person has become familiar with a wide range of symptoms that require checks to be carried out, such as based on the results of a hazard assessment or a daily inspection.
- Recent professional involvement in the field of the industrial truck test in question and an appropriate further qualification are essential. The qualified person must have experience of carrying out the test in question or of carrying out similar tests. Moreover, this person must be aware of the latest technological developments.



regarding the industrial truck to be tested and the risk being assessed

Drivers

This truck may only be driven by suitable persons who are at least 18 years of age, have been trained in driving, have demonstrated their skills in driving and handling loads to the operating company or an authorised representative, and have been specifically instructed to drive the truck. Specific knowledge of the truck to be operated is also required.

The training requirements under §3 of the Health and Safety at Work Act and §9 of the plant safety regulations are deemed to have been satisfied if the driver has been trained in accordance with BGG (General Employers' Liability Insurance Association Act) 925. Observe the national regulations for your country.

Driver rights, duties and rules of behaviour

The driver must be trained in his rights and duties.

The driver must be granted the required rights.

The driver must wear protective equipment (protection suit, safety footwear, safety helmet, industrial goggles and gloves) that is appropriate for the conditions, the job and the load to be lifted. Solid footwear should be worn to ensure safe driving and braking.

The driver must be familiar with the operating instructions and have access to them at all times.

The driver must:

- have read and understood the operating manual
- have familiarised himself with safe operation of the truck
- be physically and mentally able to drive the truck safely



Definition of responsible persons

⚠ DANGER

The use of drugs, alcohol or medications that affect reactions impair the ability to drive the truck!

Individuals under the influence of the aforementioned substances are not permitted to perform work of any kind on or with the truck.

Prohibition of use by unauthorised persons

The driver is responsible for the truck during working hours. He must not allow unauthorised persons to operate the truck.

When leaving the truck, the driver must secure it against unauthorised use, e.g. by pulling out the key.



Basic principles for safe operation

Insurance cover on company premises

In many cases, company premises are restricted public traffic areas.

 **NOTE**

The business liability insurance should be reviewed to ensure that, in the event of any damage caused in restricted public traffic areas, there is insurance cover for the truck in respect of third parties.

Changes and retrofitting

If the truck will be used for work that is not listed in the directives or in these instructions, convert or retrofit the truck for this purpose as required. Any structural modification can impair the handling and stability of the truck, and can result in accidents.

Any modifications that adversely affect the stability, the load capacity or the circumferential view of the truck require written approval from the manufacturer.

The following components may only be modified with prior written approval from the manufacturer:

- Brakes
- Steering
- Operating devices
- Safety systems
- Equipment variants
- Attachments

The truck may only be converted with written approval from the manufacturer. If necessary, obtain approval from the relevant authorities.

We warn against the installation and use of restraint systems not approved by the manufacturer.

- Contact the authorised service centre before converting or retrofitting the truck.

Basic principles for safe operation



⚠ DANGER

Risk of injury if truck tips over!

Even if an approved restraint system is in use, there is still a residual risk that the driver could be injured if the truck tips over. The risk of injury can be reduced by using the restraint system in conjunction with the seat belt. In addition, the seat belt protects against the consequences of rear-end collisions and falling off ramps.

- Use the seat belt too.

Only the authorised service centre is permitted to perform welding work on the truck.



⚠ DANGER

Risk of explosion from additional bores in the battery hood!

Explosive gases can escape and can lead to potentially fatal injuries if they explode. Sealing bores with plugs is not sufficient to prevent gas from escaping.

- Do not drill any holes in the battery hood.

⚠ DANGER

Risk of accident from additional holes in the battery hood!

The rigidity of the battery hood is impaired and the battery hood can break. The driver's seat may collapse into the battery hood, which could cause the driver to perform uncontrolled steering and driving manoeuvres.

- Do not drill any holes in the battery hood.

⚠ DANGER

Risk to life from falling load!

There is a risk to the driver's life if the truck is not equipped with an overhead guard, as the driver may be struck by a load falling from a lift height of 1800 mm or greater.

Operation of the truck without an overhead guard is prohibited at a lift height greater than 1800 mm.

- At lift heights of 1800 mm and above, only use the truck in conjunction with an overhead guard.

The operating company is only permitted to make modifications to the truck independently

if the manufacturer goes into liquidation and the company is not taken over by another legal person.

The operating company must also fulfil the following prerequisites:

- Design documents, test documents and assembly instructions associated with the modification must be permanently archived and remain accessible at all times.
- The capacity rating plate, the decal information, the hazard warnings and the operating instructions must be checked to ensure that they are consistent with the modifications and must be amended if required.
- Modifications must be designed, checked and implemented by a design office that specialises in industrial trucks. The design office must comply with the standards and directives valid at the time that modifications are made.

Decal information with the following data must be permanently affixed to the truck so that it is clearly visible:

- Type of modification
- Date of modification
- Name and address of the company that carried out the modification

Changes to the overhead guard and roof loads

DANGER

In the event of the overhead guard failing due to a falling load or the truck tipping over, there are potentially fatal consequences for the driver. There is a risk to life!

Welding and drilling on the overhead guard changes the material characteristics and the structural design of the overhead guard. Excessive forces caused by falling loads or the truck tipping over may result in buckling of the modified overhead guard and no protection for the driver.

- Do not perform welding on the overhead guard.
- Do not perform drilling on the overhead guard.



Basic principles for safe operation

⚠ CAUTION

Heavy roof loads damage the overhead guard!

To ensure the stability of the overhead guard at all times, a roof load may only be mounted on the overhead guard if the structural design has been tested and the manufacturer has given approval.

- Seek advice from the authorised service centre for the mounting of roof loads.

Warning regarding non-original parts

Original parts, attachments and accessories are specially designed for this truck. We specifically draw your attention to the fact that parts, attachments and accessories supplied by other companies have not been tested and approved by STILL.

⚠ CAUTION

Installation and/or use of such products may therefore have a negative impact on the design features of the truck and thus impair active and/or passive driving safety.

We recommend that you obtain approval from the manufacturer and, if necessary, from the relevant regulatory authorities before installing such parts. The manufacturer accepts no liability for any damage caused by the use of non-original parts and accessories without approval.

Damage, defects and misuse of safety systems

Damage or other defects on the truck or attachment must be reported to the supervisor or responsible fleet manager immediately so that they can have the defect rectified.

Trucks and attachments that are not functional or safe to drive may not be used until they have been properly repaired.

Do not remove or deactivate safety systems and switches.

Fixed set values may only be changed with the approval of the manufacturer.

Work on the electrical system (e.g. connecting a radio, additional headlights etc.) is only

permitted with the manufacturer's written approval. All electrical system interventions must be documented.

Even if they are removable, roof panels may not be removed, as they are designed to protect against small falling objects.

Tyres

DANGER

Risk to stability!

Failure to observe the following information and instructions can lead to a loss of stability. The truck may tip over, risk of accident!

The following factors can lead to a loss of stability and are therefore **prohibited**:

- Different tyres on the same axle, e.g. pneumatic tyres and superelastic tyres
- Tyres not approved by the manufacturer
- Excessive tyre wear
- Tyres of inferior quality
- Changing rim wheel parts
- Combining rim wheel parts from different manufacturers

The following rules must be observed to ensure stability:

- Only use tyres with equal and permitted levels of wear on the same axle
- Only use wheels and tyres of the same type on the same axle, e.g. only superelastic tyres
- Only use wheels and tyres approved by the manufacturer
- Only use high-quality products

Wheels and tyres approved by the manufacturer can be found on the spare parts list. If other wheels or tyres are to be used, authorisation from the manufacturer must be obtained beforehand.

- Contact the authorised service centre on this matter.

When changing wheels or tyres, always ensure that this does not cause the truck to



Basic principles for safe operation

tilt to one side (e.g. always replace right-hand and left-hand wheels at the same time). Changes must only be made following consultation with the manufacturer.

If the type of tyre used on an axle is changed, for example from superelastic tyres to pneumatic tyres, the load diagram must be changed accordingly.

- Contact the authorised service centre on this matter.

Medical equipment

WARNING

Electromagnetic interference may occur on medical devices!

Only use equipment that is sufficiently protected against electromagnetic interference.

Medical equipment, such as pacemakers or hearing aids, may not work properly when the truck is in operation.

- Ask your doctor or the manufacturer of the medical equipment to confirm that the medical equipment is sufficiently protected against electromagnetic interference.

Exercise caution when handling gas springs and accumulators

⚠ WARNING

Gas springs are under high pressure. Improper removal results in an elevated risk of injury.

For ease of operation, various functions on the truck can be supported by gas springs. Gas springs are complex components that are subject to high internal pressures (up to 300 bar). They may under no circumstances be opened unless instructed to do so, and may be installed only when not under pressure. If required, the authorised service centre will depressurise the gas spring in accordance with the regulations before removal. Gas springs must be depressurised before recycling.

- Avoid damage, lateral forces, buckling, temperatures over 80°C and heavy contamination.
- Damaged or defective gas springs must be changed immediately.
- Contact the authorised service centre.

⚠ WARNING

Accumulators are under high pressure. Improper installation of an accumulator results in an elevated risk of injury.

Before starting work on the accumulator it must be depressurised.

- Contact the authorised service centre.

Length of the fork arms

⚠ DANGER

Risk of accident due to the incorrect selection of fork arms!

- The fork arms must match the depth of the load.

If the fork arms are too short, the load may fall off the arms after it has been picked up. In addition, be aware that the load centre of gravity may shift as a result of dynamic forces, such as braking. A load that is otherwise resting safely on the fork arms may move forwards and fall.

If the fork arms are too long, they can catch on loading units behind the load that is to be



2

Safety

Basic principles for safe operation

picked up. These other loading units then fall over when the load is raised.

- For help with selecting the correct fork arms, contact the authorised service centre.



Residual risk

Residual dangers, residual risks

Despite careful working and compliance with standards and regulations, the occurrence of other risks when using the truck cannot be entirely excluded.

The truck and all other system components comply with current safety requirements. Nevertheless, even when the truck is used for its proper purpose and all instructions are followed, some residual risk cannot be excluded.

Even beyond the narrow danger areas of the truck itself, a residual risk cannot be excluded. Persons in this area around the truck must exercise a heightened degree of awareness, so that they can react immediately in the event of any malfunction, incident or breakdown etc.

⚠ WARNING

All persons that are in the vicinity of the truck must be instructed regarding these risks that arise through use of the truck.

In addition, we draw attention to the safety regulations in these operating instructions.

Risks can include:

- Escape of consumables due to leakages, rupture of lines and containers etc.
- Risk of accident when driving over difficult ground such as gradients, smooth or irregular surfaces, or with poor visibility etc.
- Falling, tripping etc. when moving on the truck, especially in wet weather, with leaking consumables or on icy surfaces
- Fire and explosion risks due to batteries and electrical voltages
- Human error resulting from failure to observe the safety regulations,
- Unrepaired damage or defective and worn components,
- Insufficient maintenance and testing
- Use of incorrect consumables
- Exceeding test intervals



Residual risk

The manufacturer is not held responsible for accidents involving the truck caused by the failure of the operating company to comply with these regulations either intentionally or carelessly.

Stability

The stability of the truck has been tested to the latest technological standards and is guaranteed provided that the truck is used properly and according to its intended purpose. These standards only take into account the dynamic and static tipping forces that can arise during specified use in accordance with the operating rules and intended purpose. However, the danger of exceeding the moment of tilt due to improper use or incorrect operation and losing stability can never be excluded.

The loss of stability can be avoided or minimised by the following actions:

- Always secure the load against slipping, e.g. by lashing.
- Always transport unstable loads in suitable containers.
- Always drive slowly when cornering.
- Drive with the load lowered.
- Even with sideshifts, align the load as centrally as possible with the truck and transport in this position.
- Avoid turning and diagonally driving across slopes or gradients.
- Never have the load facing downhill when travelling on slopes or gradients.
- Pick up only loads of the approved width.
- Always take great care when transporting suspended loads.
- Do not drive over ramp edges or steps.

Special risks associated with using the truck and attachments

Approval from the manufacturer and attachment manufacturer must be obtained each



Safety

2

Residual risk

time the truck is used in a manner that falls outside the scope of normal use, and in cases where the driver is not certain that he can use the truck correctly and without the risk of accidents.



Residual risk

Overview of hazards and counter-measures

i NOTE

This table is intended to help evaluate the hazards in your facility and applies to all drive types. It does not claim to be complete.

- Observe the national regulations for the country in which the truck is being used.

Hazard	Measure	Check note √ Complete - Not applicable	Notes
Truck equipment does not comply with local regulations	Test	○	If in doubt, consult competent factory inspectorate or employers' liability insurance association
Lack of skills and qualification of driver	Driver training (sit-on and stand-on)	○	BGG 925 VDI 3313 driver permit
Usage by unauthorised persons	Access with key only for authorised persons	○	
Truck not in a safe condition	Recurrent testing and rectification of defects	○	German Ordinance on Industrial Safety and Health (BetrSichV)
Risk of falling when using working platforms	Compliance with national regulations (different national laws)	○	German Ordinance on Industrial Safety and Health (BetrSichV) and employer's liability insurance associations
Impaired visibility due to load	Resource planning	○	German Ordinance on Industrial Safety and Health (BetrSichV)
Contamination of respiratory air	Assessment of diesel exhaust gases	○	Technical Regulations for Hazardous Substances (TRGS) 554 and the German Ordinance on Industrial Safety and Health (BetrSichV)
	Assessment of LPG exhaust gases	○	German threshold limit values list (MAK-Liste) and the German Ordinance on Industrial Safety and Health (BetrSichV)



Safety

2

Residual risk

Hazard	Measure	Check note √ Complete - Not applicable	Notes
Impermissible usage (improper usage)	Issuing of operating instructions	○	German Ordinance on Industrial Safety and Health (BetrSichV) and German Health and labour protection law (ArbSchG)
	Written notice of instruction to driver	○	German Ordinance on Industrial Safety and Health (BetrSichV) and German Health and labour protection law (ArbSchG)
	Note the German Ordinance on Industrial Safety and Health (BetrSichV), the operating instructions and the German Engineering Federation (VDMA) rules	○	
When fuelling			
a) Diesel	Note the German Ordinance on Industrial Safety and Health (BetrSichV), the operating instructions and the German Engineering Federation (VDMA) rules	○	
b) LPG	Note German Social Accident Insurance (DGUV) regulation D34, the operating instructions and the German Engineering Federation (VDMA) rules	○	



2

Safety

Residual risk

Hazard	Measure	Check note √ Complete - Not applicable	Notes
When charging the traction battery	Note the German Ordinance on Industrial Safety and Health (BetrSichV), the operating instructions and the German Engineering Federation (VDMA) rules	○	Association for Electrical, Electronic and Information Technologies (VDE) regulation 0510: In particular - Ensure adequate ventilation - Insulation value within the permissible range
When using battery chargers	Note the German Ordinance on Industrial Safety and Health (BetrSichV), employers' liability insurance association regulation 104 and the operating instructions	○	German Ordinance on Industrial Safety and Health (BetrSichV) and employers' liability insurance association regulation 104
When parking LPG trucks	Note the German Ordinance on Industrial Safety and Health (BetrSichV), employers' liability insurance association regulation 104 and the operating instructions	○	German Ordinance on Industrial Safety and Health (BetrSichV) and employers' liability insurance association regulation 104
With driverless transport systems			
Roadway quality inadequate	Clean/clear driveways	○	German Ordinance on Industrial Safety and Health (BetrSichV)
Load carrier incorrect/slipped	Reattach load to pallet	○	German Ordinance on Industrial Safety and Health (BetrSichV)
Drive behaviour unpredictable	Employee training	○	German Ordinance on Industrial Safety and Health (BetrSichV)
Driveways blocked	Mark driveways Keep driveways clear	○	German Ordinance on Industrial Safety and Health (BetrSichV)
Driveways intersect	Announce right-of-way rule	○	German Ordinance on Industrial Safety and Health (BetrSichV)
No person detection during depositing and retrieval	Employee training	○	German Ordinance on Industrial Safety and Health (BetrSichV)

Danger to employees

According to the German Ordinance on Industrial Safety and Health (BetrSichV) and labour protection law (ArbSchG), the operating company must determine and assess hazards during operation, and establish the labour protection measures required for employees (BetrSichVO). The operating company must therefore draw up appropriate operating instructions (§ 6 ArbSchG) and make them available to the driver. A responsible person must be appointed.

NOTE

Please observe the definition of the following responsible persons: "operating company" and "driver".

The construction and equipment of the truck correspond to the Machinery Directive 2006/42/EC and are therefore marked with CE labelling. These elements are therefore not included in the hazard assessment. Attachments possess their own CE labelling and likewise are not included for that reason. The operating company must, however, select the type and equipment of the trucks so as to comply with the local provisions for deployment.

The result must be documented (§ 6 ArbSchG). In the case of truck applications involving similar hazard situations, the results may be summarised. This overview (see chapter "Overview of hazards and countermeasures") provides help on complying with this regulation. The overview specifies the main hazards that are the most frequent cause of accidents in the event of non-compliance. If other major operational hazards are involved, they must also be taken into consideration.

The conditions of use for trucks are broadly similar in many plants, so the hazards can be summarised in one overview. Observe the information provided by the relevant employers' liability insurance association on this subject.

Safety tests

Safety tests

Regular safety inspection of the truck ▷

Safety inspection based on time and extraordinary incidents

The operating company must ensure that the truck is checked by a specialist at least once a year or after particular incidents.

As part of this inspection, a complete check of the technical condition of the truck must be performed with regard to accident safety. In addition, the truck must be thoroughly checked for damage that could potentially have been caused by improper use. A test log must be created. The results from the inspection must be retained until a further two inspections have been carried out.

The inspection date is indicated by an adhesive label on the truck.

- Arrange for the service centre to perform periodic safety inspections on the truck.
- Observe guidelines for checks carried out on the truck in accordance with FEM 4.004.

The operator is responsible for ensuring any defects are remedied without delay.

- Contact your service centre.

i NOTE

Observe the national regulations for your country!

Insulation testing

The insulation of the truck must have sufficient insulation resistance. For this reason, insulation testing in accordance with DIN EN 1175 and DIN 43539, VDE 0117 and VDE 0510 must be conducted at least once yearly as part of the FEM testing.

The insulation testing results must be at least the test values given in the following two tables.

- For insulation testing, contact the authorised service centre.



The exact procedure for this insulation testing is described in the workshop manual for this truck.

 **NOTE**

The truck's electrical system and drive batteries must be checked separately.

Test values for the drive battery

Component	Recommended test voltage	Measurements		Nominal voltage U_{Batt}	Test values
Battery	50 VDC	Batt+ Batt-	Battery tray	24 volts	> 1200 Ω
	100 VDC			48 volts	> 2400 Ω
	100 VDC			80 volts	> 4000 Ω

Test values for the entire truck

Nominal voltage	Test voltage	Test values for new trucks	Minimum values over the duration of the service life
24 volts	50 VDC	Min. 50 k Ω	> 24 k Ω
48 volts	100 VDC	Min. 100 k Ω	> 48 k Ω
80 volts	100 VDC	Min. 200 k Ω	> 80 k Ω

Safety regulations for handling consumables

Safety regulations for handling consumables

Permissible consumables

DANGER

Failure to observe the safety regulations relating to consumables may result in a risk of injury, death or damage to the environment.

- Observe the safety regulations when handling such materials.

Refer to the maintenance data table for the permissible substances that are necessary for operation (see ⇒ Chapter "Maintenance data table", P. 5-325).

Oils



DANGER

Oils are flammable!

- Follow the statutory regulations.
- Do not allow oils to come into contact with hot engine parts.
- No smoking, fires or naked flames!



DANGER

Oils are toxic!

- Avoid contact and consumption.
- If vapour or fumes are inhaled, move to fresh air immediately.
- In the event of contact with the eyes, rinse thoroughly (for at least 10 minutes) with water and then consult an eye specialist.
- If swallowed, do not induce vomiting. Seek immediate medical attention.



⚠ WARNING

Prolonged intensive contact with the skin can result in dryness and irritate the skin!

- Avoid contact and consumption.
- Wear protective gloves.
- After any contact, wash the skin with soap and water, and then apply a skin care product.
- Immediately change soaked clothing and shoes.

⚠ WARNING

There is a risk of slipping on spilled oil, particularly when combined with water!

- Spilt oil should be removed immediately with oil-binding agents and disposed of according to the regulations.



ENVIRONMENT NOTE

Oil is a water-polluting substance!

- *Always store oil in containers that comply with the applicable regulations.*
- *Avoid spilling oils.*
- *Spilt oil should be removed immediately with oil-binding agents and disposed of according to the regulations.*
- *Dispose of old oils according to the regulations.*

Hydraulic fluid



⚠ WARNING

These fluids are pressurised during operation of the truck and are hazardous to your health.

- Do not spill the fluids.
- Follow the statutory regulations.
- Do not allow the fluids to come into contact with hot engine parts.

Safety regulations for handling consumables



⚠ WARNING

These fluids are pressurised during operation of the truck and are hazardous to your health.

- Do not allow the fluids to come into contact with the skin.
- Avoid inhaling spray.
- Penetration of pressurised fluids into the skin is particularly dangerous if these fluids escape at high pressure due to leaks in the hydraulic system. In case of such injury, immediate medical assistance is required.
- To avoid injury, use appropriate personal protective equipment (e.g. protective gloves, industrial goggles, skin protection and skin care products).



ENVIRONMENT NOTE

Hydraulic fluid is a water-polluting substance.

- *Always store hydraulic fluid in containers that comply with regulations*
- *Avoid spills*
- *Spilt hydraulic fluid should be removed immediately with oil-binding agents and disposed of according to the regulations*
- *Dispose of old hydraulic fluid according to the regulations*

Battery acid



⚠ WARNING

Battery acid contains dissolved sulphuric acid. This is toxic.

- Avoid touching or swallowing the battery acid at all costs.
- In case of injury, seek medical advice immediately.



⚠ WARNING

Battery acid contains dissolved sulphuric acid. This is corrosive.

- When working with battery acid, use appropriate PSA (rubber gloves, apron, protection goggles).
- When working with battery acid, never wear a watch or jewellery.
- Do not allow any acid to get onto clothing or skin or into the eyes. If this does happen, rinse immediately with plenty of clean water.
- In case of injury, seek medical advice immediately.
- Immediately rinse away spilt battery acid with plenty of water.
- Follow the statutory regulations.



ENVIRONMENT NOTE

- Dispose of used battery acid in line with the applicable regulations.

Coolant and cooling fluid



⚠ WARNING

Coolant and cooling fluid can be hazardous to your health and the environment!

Coolants are chemical corrosion inhibitors and cooling system protecting agents such as Glysantin. The cooling fluid is an appropriate mixture of water and coolant. Coolant in both concentrated and dilute form can be hazardous to your health if swallowed, or hazardous to the environment if spilled.

- Store coolant and cooling fluid only in their original containers and do not spill them.
- Never store coolant or cooling fluid in empty food containers, bottles or other containers.
- Observe the national regulations for the country of use.



ENVIRONMENT NOTE



Safety regulations for handling consumables

- Soak up any spilt coolant or cooling fluid immediately using an oil binding agent and dispose of it in accordance with the national regulations for the country of use.
- Dispose of old coolant or cooling fluid in accordance with the national regulations for the country of use.

Disposal of consumables



ENVIRONMENT NOTE

Materials that accumulate during repair, maintenance and cleaning must be collected properly and disposed of in accordance with the national regulations for the country in which the truck is being used. Work must only be carried out in areas designated for that purpose. Care must be taken to minimise any environmental pollution.

- Soak up any spilt fluids such as hydraulic oil or gearbox oil immediately using an oil-binding agent.
- Neutralise any spilt battery acid immediately.
- Always observe national regulations concerning the disposal of used oil.



Emissions

The values specified apply to a standard truck (compare the specifications in the "Technical data" chapter). Different tyres, lift masts, additional units etc. may produce different values.

Noise emissions

The values were determined based on measuring procedures from the standard EN 12053 "Safety of industrial trucks. Test methods for measuring noise emissions", based on EN 12001, EN ISO 3744 and the requirements of EN ISO 4871.

This machine emits the following sound pressure level:

Continuous sound pressure level in the driver's compartment

LpAZ	Measurement uncertainty KpA
< 70 dB(A)	4 dB(A)

The values were determined in the test cycle on an identical machine from the weighted values for operating statuses and idling.

Time proportions:

- Lifting 18%
- Idling 58%
- Driving 24%

However, the noise levels indicated on the truck cannot be used to determine the noise emissions at workplaces according to the most recent version of **Directive 2003/10/EC** (daily personal noise pollution). If necessary, these noise emissions should be determined by the operating company directly at the workplace under the actual conditions there (additional noise sources, special application conditions, sound reflections).

NOTE

Please note the definition of "operating company" in the sense of responsible persons!

Emissions

Vibrations

The vibrations of the machine have been determined on an identical machine in accordance with the standards DIN EN 13059 "Safety of industrial trucks - Test methods for measuring vibration" and DIN EN 12096 "Mechanical vibration - Declaration and verification of vibration emission values".

Frequency-weighted effective value of acceleration on the seat

MSG 65 driver's seat	Measurement uncertainty
0.31 m/s ²	0.093 m/s ²

Tests have indicated that the amplitude of the hand and arm vibrations on the steering wheel or the operating devices in trucks is less than 2.5 m/s². There are therefore no measurement guidelines for these measurements.

The personal vibration load on the driver over a working day must be determined by the operating company at the actual place of use in accordance with **Directive 2002/44/EC**, in order to consider all additional influences, such as driving route, intensity of use etc.

NOTE

Please note the definition of "operating company" in the sense of responsible persons!



Battery



⚠ DANGER

Risk of explosion due to flammable gases!

During charging, the battery releases a mixture of oxygen and hydrogen (oxyhydrogen gas). This gas mixture is explosive and must not be ignited.

- Make sure that there is always sufficient ventilation in working areas that are entirely or partially enclosed.
- Keep away from open flames and flying sparks.
- Do not smoke.
- Observe the safety regulations for handling the battery.



2

Emissions

Safety



3

Overviews

3 Overview

Overview

Overview

Left-hand side (when viewed in the drive direction)

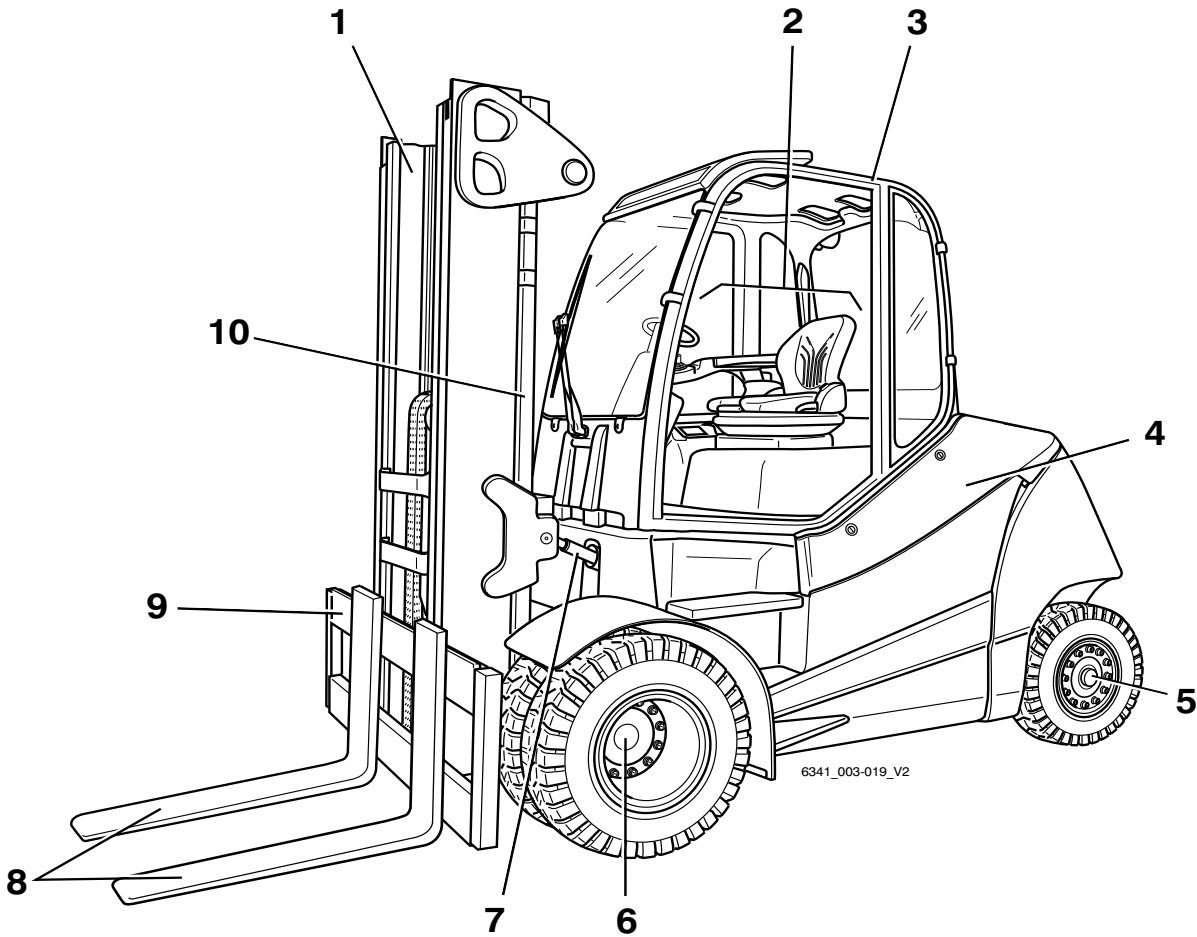

- | | | | |
|---|----------------------|----|---------------|
| 1 | Lift mast | 6 | Drive axle |
| 2 | Driver's compartment | 7 | Tilt cylinder |
| 3 | Overhead guard | 8 | Fork arms |
| 4 | Left side cover | 9 | Fork carriage |
| 5 | Steering axle | 10 | Lift cylinder |

Right-hand side (when viewed in the drive direction)

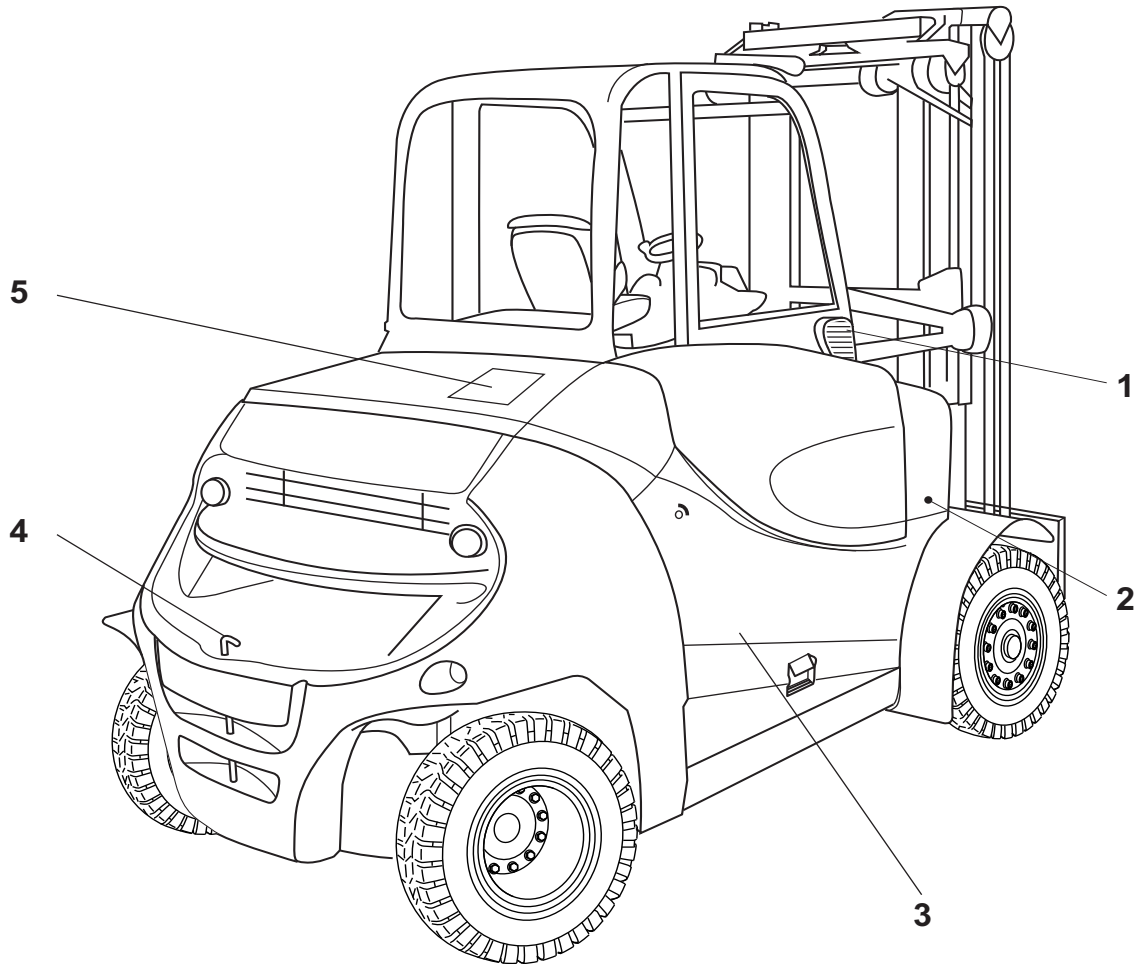

- 1 Fresh air filter for heating system
- 2 Cover, front right
- 3 Battery cover
- 4 Coupling pin
- 5 Rear cover

Driver's compartment

Driver's compartment

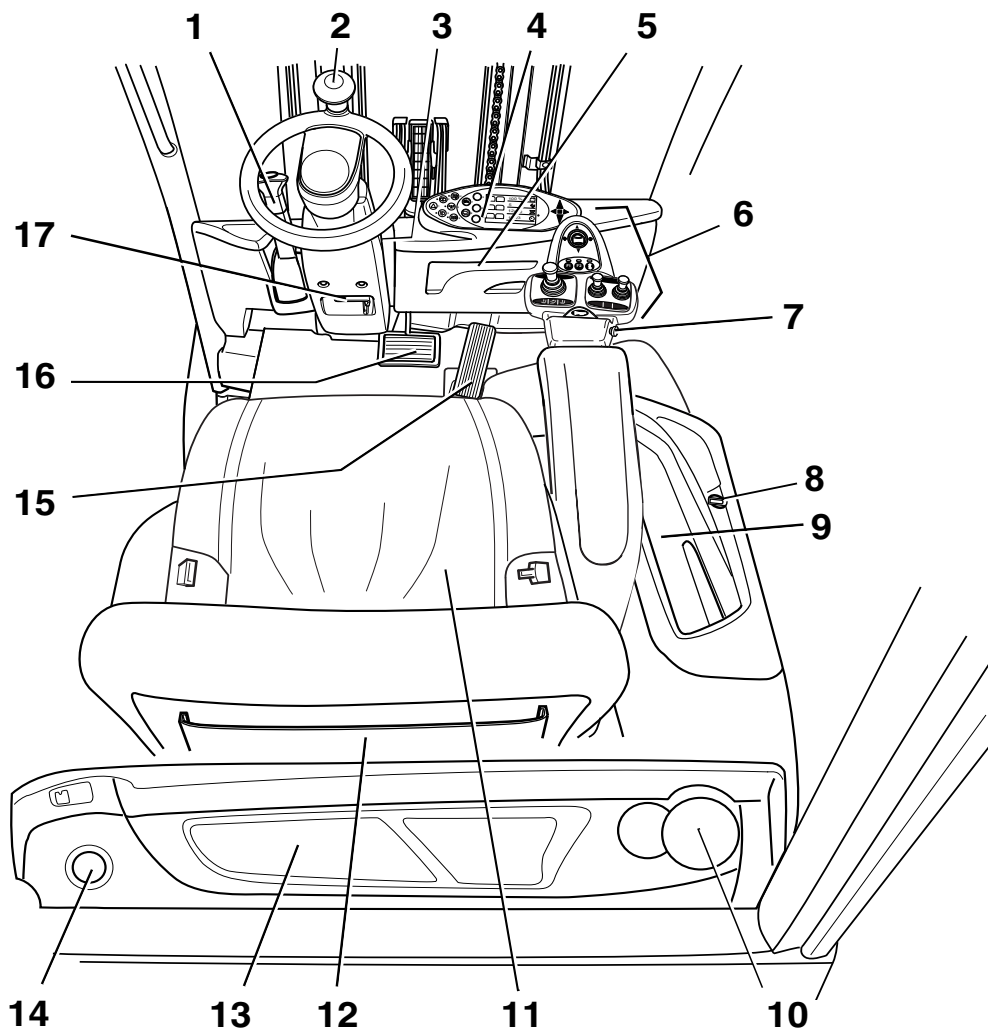

- | | | | |
|---|--|----|--|
| 1 | Parking brake lever | 10 | Bottle holder for bottles of max. 0.5 l |
| 2 | Steering wheel | 11 | Driver's seat |
| 3 | Key switch | 12 | Storage compartment / storage compartment with cover (variant) |
| 4 | Display and operating unit | 13 | Compartment |
| 5 | Document holder / storage compartment for operating instructions | 14 | Filler cap for windscreen washer reservoir (variant) |
| 6 | Operating devices for hydraulic and traction functions | 15 | Accelerator pedal |
| 7 | Emergency off switch | 16 | Brake pedal |
| 8 | 12-V socket | 17 | Steering column adjustment lever |
| 9 | Compartment | | |

i NOTE

The truck equipment may differ from the equipment shown.

Operating and display elements

Display operating unit

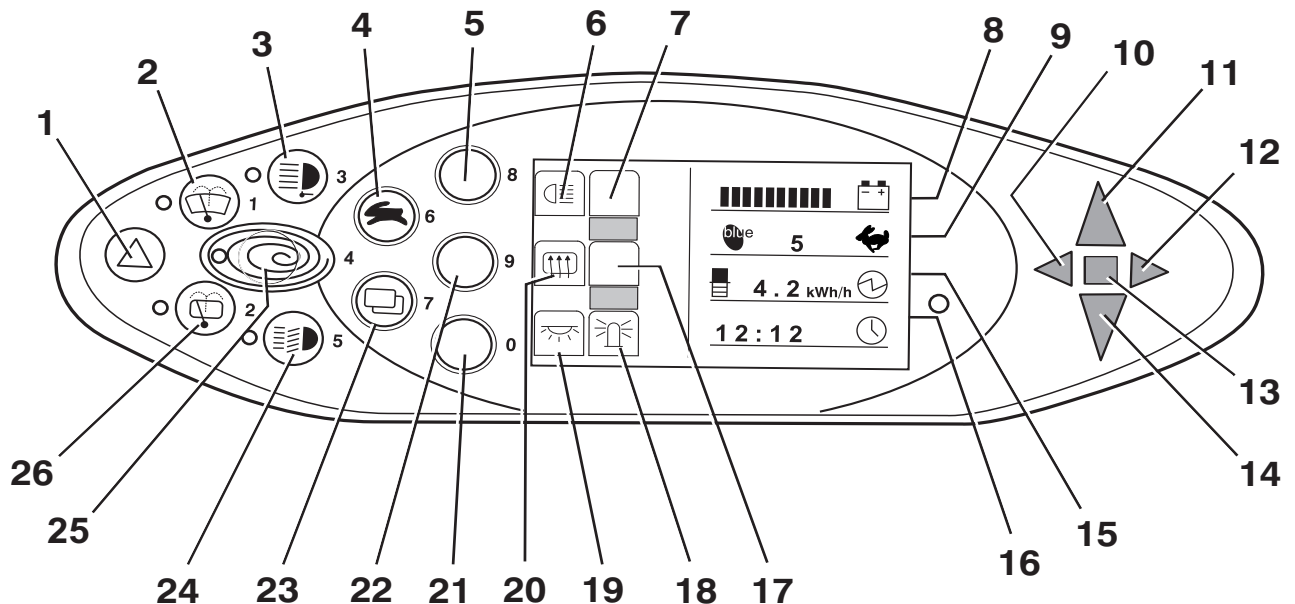

- | | | | |
|----|-------------------------------------|----|--|
| 1 | Hazard warning system button | 14 | Reverse travel display |
| 2 | Front windscreen wiper button | 15 | Power rating display |
| 3 | Working spotlight button | 16 | Time display (digital) |
| 4 | Drive programme selector button | 17 | Not assigned |
| 5 | Softkey for lighting | 18 | Rotating beacon display |
| 6 | Lighting symbol | 19 | Interior light display |
| 7 | Not assigned | 20 | Rear window heating display |
| 8 | Battery charge display | 21 | Softkey for interior light/rotating beacon |
| 9 | Drive programme display (numerical) | 22 | Softkey for rear window heating |
| 10 | Left direction indicator light | 23 | Menu change button |
| 11 | Forward travel display | 24 | Lighting button |
| 12 | Right direction indicator light | 25 | Blue-Q button |
| 13 | Malfunction display | 26 | Rear window wiper button |

NOTE

The Softkeys (5, 21, 22) and the corresponding indicators (6, 7, 18, 19, 20) are assigned according to the auxiliary equipment installed.

The assignment shown here is an example and may differ from the assignment actually programmed on the truck. Softkeys can be assigned multiple functions that are called up according to the menu navigation. For further information, see the section entitled "Operating the display-operating unit".

- If you have any questions, please contact your authorised service centre.



Operating and display elements

Operating devices for hydraulic and driving functions

Different versions of the operating devices are available for operating the truck's hydraulic and traction functions.

The truck can be equipped with the following operating devices:

- **Double mini-lever**
- **Triple mini-lever**
- **Quadruple mini-lever**
- **Joystick 4Plus**
- **Fingertip switch**
- **Mini-console**

Double mini-lever

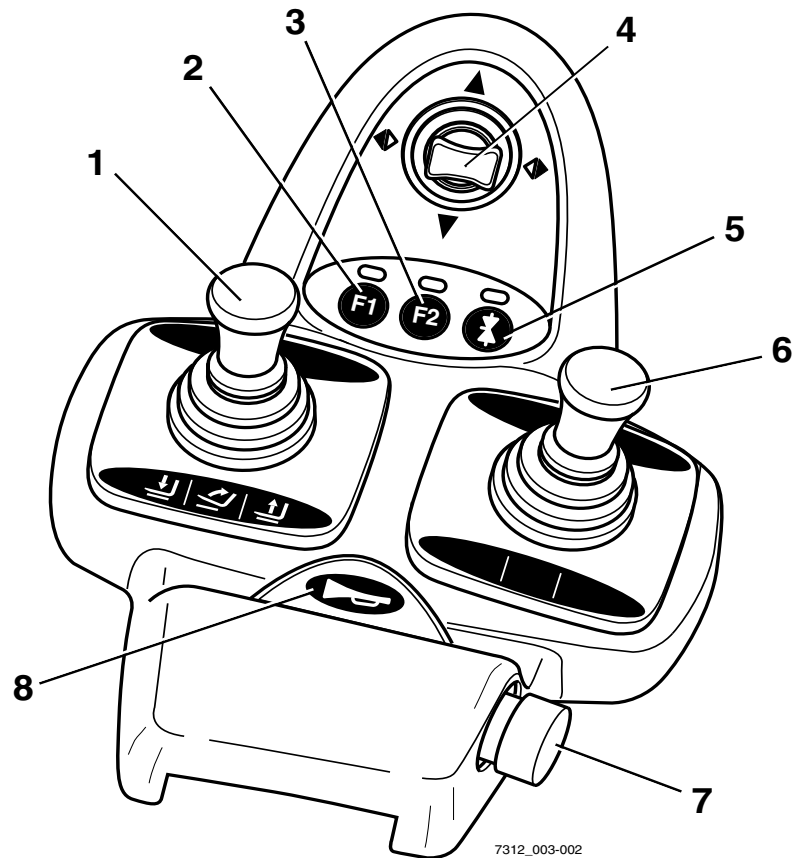

- | | | | |
|---|--|---|-----------------------------|
| 1 | "Lift mast" 360° lever | 5 | Function key "5th function" |
| 2 | Function key F1 | 6 | "Attachments" cross lever |
| 3 | Function key F2 | 7 | Emergency stop switch |
| 4 | "Drive direction / turn indicator" cross lever | 8 | Signal horn button |

i NOTE

Depending on the specification, various electric attachment parts can be controlled via function keys (2) and (3). Changes must only be made by the authorised service centre.

3 Overviews

Operating and display elements

Three-way mini-lever

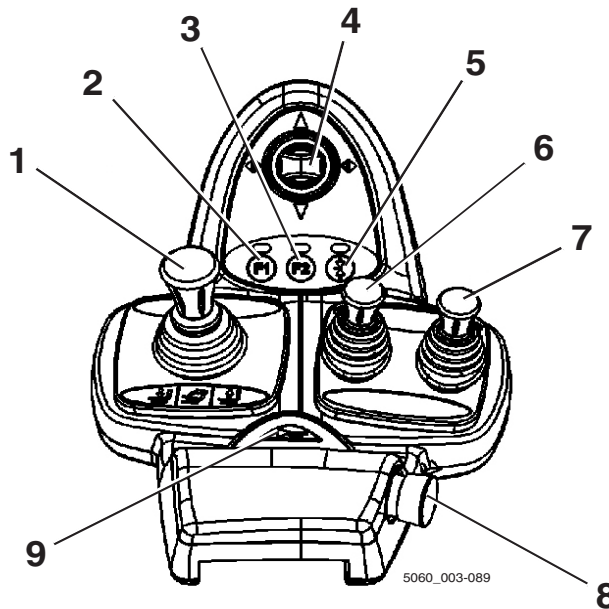

- | | | | |
|---|--|---|--|
| 1 | "Lift mast" 360° lever | 6 | "Auxiliary hydraulics 1" operating lever |
| 2 | Function key F1 | 7 | "Auxiliary hydraulics 2" operating lever |
| 3 | Function key F2 | 8 | Emergency stop switch |
| 4 | "Drive direction / turn indicator" cross lever | 9 | Signal horn button |
| 5 | Function key "5th function" | | |

i NOTE

Depending on the specification, various electric attachment parts can be controlled via function keys (2) and (3). Changes must only be made by the authorised service centre.

Four-way mini-lever

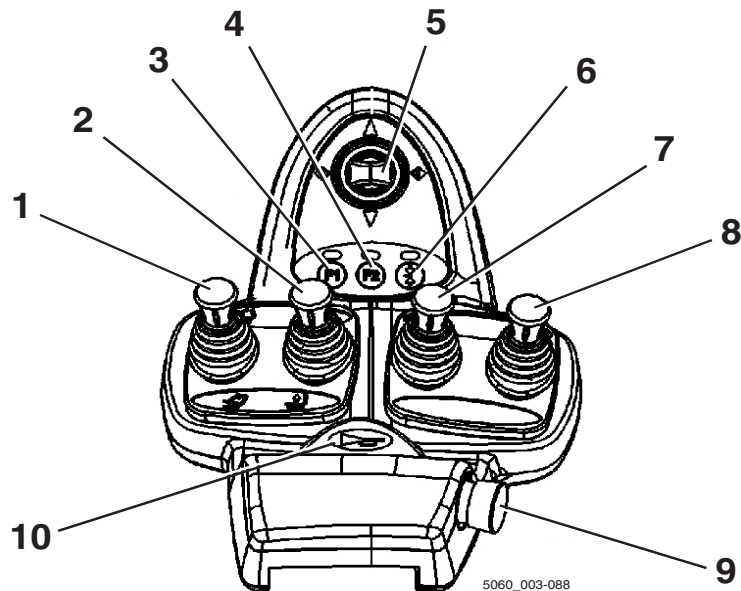

- | | | | |
|---|--|----|--|
| 1 | "Lift/lower" operating lever | 6 | Function key "5th function" |
| 2 | "Tilt" operating lever | 7 | "Auxiliary hydraulics 1" operating lever |
| 3 | Function key F1 | 8 | "Auxiliary hydraulics 2" operating lever |
| 4 | Function key F2 | 9 | Emergency stop switch |
| 5 | "Drive direction / turn indicator" cross lever | 10 | Signal horn button |

i NOTE

Depending on the specification, various electric attachment parts can be controlled via function keys (3) and (4). Changes must only be made by the authorised service centre.

3 Overviews
Operating and display elements

Joystick 4Plus

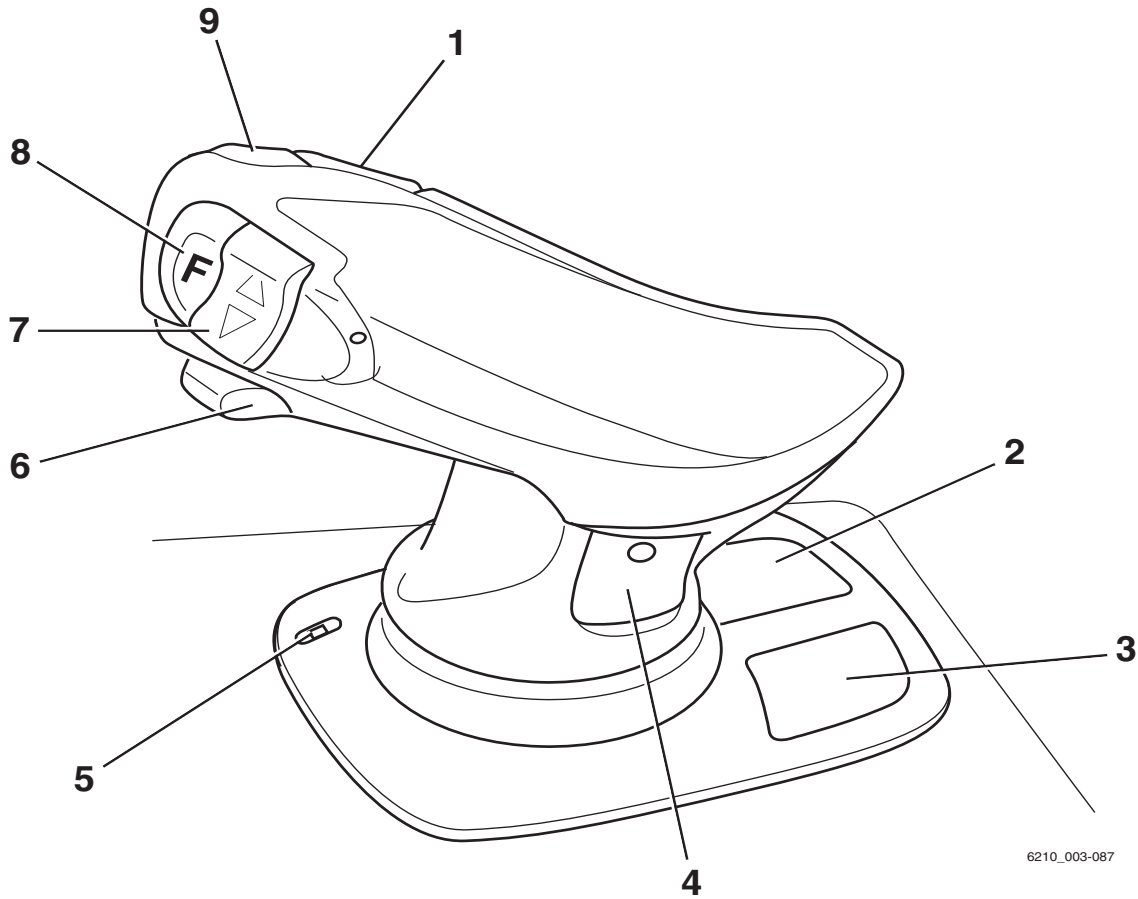

6210_003-087

- | | |
|---|---|
| <p>1 Horizontal rocker button for "3rd hydraulic function", tilt the lift mast</p> <p>2 Pictograms for the basic hydraulic functions</p> <p>3 Pictograms for the 5th hydraulic function and the clamp locking mechanism (variant)</p> <p>4 Pictograms for the 3rd & 4th hydraulic functions</p> | <p>5 LED for clamp locking mechanism (variant)</p> <p>6 Slider for the "4th hydraulic function", e.g. reach frame forwards/backwards</p> <p>7 Vertical rocker button for the "drive direction"</p> <p>8 Shift key "F"</p> <p>9 Signal horn button</p> |
|---|---|

Fingertip

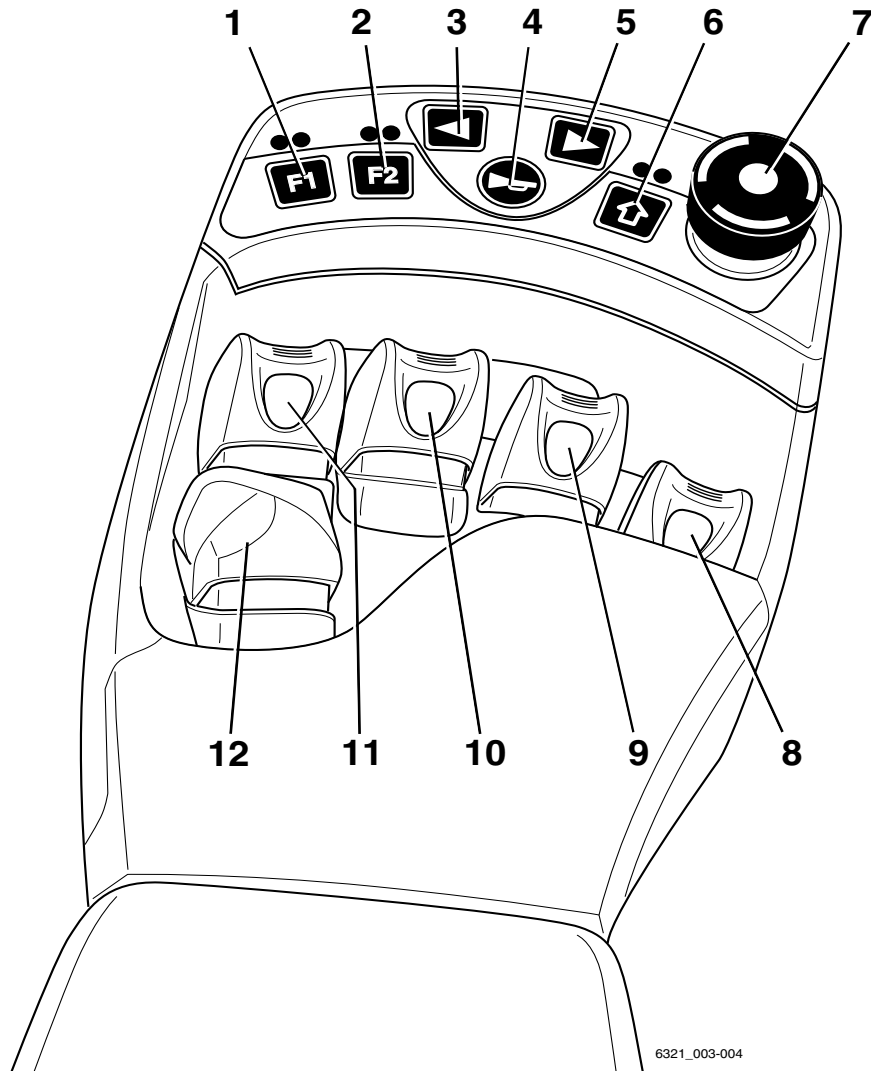

6321_003-004

- | | | | |
|---|----------------------------------|----|-------------------------------|
| 1 | Function key F1 | 7 | Emergency stop switch |
| 2 | Function key F2 | 8 | "Attachments" operating lever |
| 3 | Left-hand turn indicator button | 9 | "Attachments" operating lever |
| 4 | Signal horn button | 10 | "Tilt" operating lever |
| 5 | Right-hand turn indicator button | 11 | "Lift/lower" operating lever |
| 6 | Button for 5th function | 12 | Travel direction switch |

NOTE

Depending on the specification, various electric attachment parts can be controlled via function keys (1) and (2). Changes must only be made by the authorised service centre.

3

Overviews

Operating and display elements

Mini console

The mini console is located on the steering column below the steering wheel.

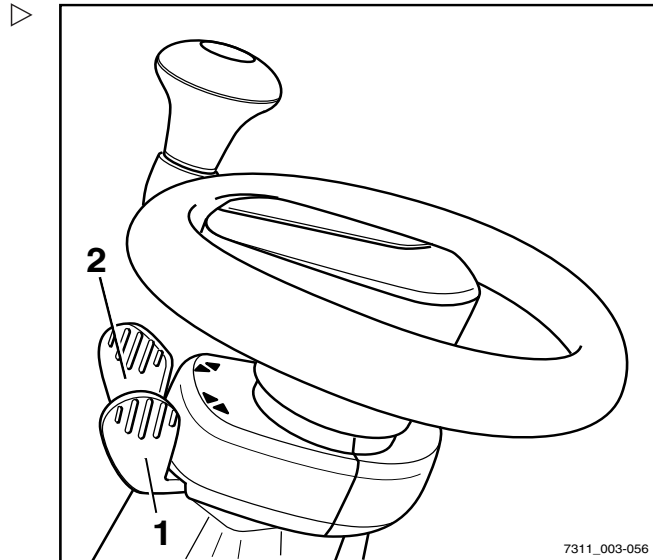

- 1 Travel direction switch
- 2 Direction indicator switch



4

Operation

Checks and tasks before daily use

Checks and tasks before daily use

Visual inspections



⚠ WARNING

Risk of injury from falling off the truck!

When climbing onto the truck, there is a risk of getting stuck or slipping and falling. Use suitable equipment to reach higher points on the truck.

- Use only the steps provided for this purpose to climb onto the truck.
- Use equipment such as stepladders or platforms to reach inaccessible areas.

Damage to the truck or the attachment (variant), non-functional switches or safety systems and modification of predefined set values can lead to unpredictable and dangerous situations.

The following checks and tasks enable causes of this type to be identified in good time. It is important to run through all the checks and tasks listed in the following table from top to bottom before daily use of the truck.

If damage or other defects are identified on the truck or the attachment (variant), the truck must not be used until it has been properly repaired.

Ensure that the truck is safe for operation each day before it is used:

Component	Course of action
Fork arms, general lifting accessories	Perform a visual inspection to check for deformation and wear (e.g. to check if they are bent, broken or feature significant wear). Check the condition and function of the fork locking devices for preventing lifting and shifting.
Lift mast roller tracks	Make sure that there is a film of grease.
Load chains	Perform a visual inspection to ensure that the chains are intact and have adequate and even tension.



Operation

4

Checks and tasks before daily use

Component	Course of action
Attachments (variant)	<p>Ensure the attachments are mounted correctly in accordance with the operating instructions of the manufacturer.</p> <p>Perform a visual inspection to ensure the attachments are intact and not leaking.</p> <p>Perform checks to ensure the attachments are working correctly.</p>
Underside	<p>Check the area under the truck for leaking consumables.</p>
Overhead guard, guard grille (variant)	<p>Perform a visual inspection for integrity.</p> <p>Check for secure mounting.</p>
Steps	<p>Make sure they are clean (free of ice, not slippery).</p>
Panes of glass (variant)	<p>Perform a visual inspection for integrity.</p> <p>Make sure they are clean (also free of ice).</p>
Handholds	<p>Check for secure mounting.</p>
Maintenance lids	<p>Check the close function and close the lids.</p>
Battery	<p>Perform a visual inspection for integrity and deformation.</p> <p>Check that the battery tray is securely and correctly seated on the battery base frame.</p> <p>The battery must be level.</p>
Battery connection assembly	<p>Check the battery male connector, the plug connection and the contacts for integrity and deformation.</p> <p>Have any damaged or deformed components replaced by the authorised service centre.</p> <p>Inspect the battery male connector and the plug connection for moisture or for any foreign objects that may have become lodged. Remove any moisture or foreign objects, e.g. using compressed air.</p>
Battery cover	<p>Perform a visual inspection for integrity and deformation.</p> <p>Check the condition and function of the quick release clamp, the handles, the interlock and the latch.</p> <p>Check the close function and close the cover.</p>
Battery rack	<p>Perform a visual inspection for integrity and deformation.</p> <p>Detent cams in the battery compartment must be fully engaged in the bores of the battery base frame.</p>
Battery lock	<p>Check the condition and function.</p> <p>Swivel the battery lock all the way down.</p>



4

Operation

Checks and tasks before daily use

Component	Course of action
Coupling pin, tow coupling (variant)	Perform a visual inspection for deformation and wear (for example, bent, torn, broken). Check the securing bush in the counterweight for integrity and to ensure that it is working correctly. Check that the linchpin is present and working correctly (chain, rope, split pin).
Labelling, adhesive labels	Check for presence, integrity and legibility. Replace damaged or missing adhesive labels in accordance with the section entitled "Labelling points".
Driver's seat, seat belt	Check the integrity and function.
Lighting, warning units	Check the integrity and function.
Antistatic belt	Perform a visual inspection for integrity. Ensure cleanliness. The antistatic belt must be long enough to touch the ground adequately.
Lift and tilt cylinders, tank, valve block, hoses, pipes, connections	Perform a visual inspection for damage and leak-ages. Check the area under the truck for leaking consumables. Have damaged components replaced only by the authorised service centre.
Wheels, tyres	Perform a visual inspection for wear and damage. Make sure that only rims of the same type from the same manufacturer are fitted. In the event of uneven tyre wear, replace both tyres. Observe the safety regulations in the section entitled "Tyres".
Axle	Make sure that no consumables are escaping from the axle.
Exhaust air grille on the cover of the rear weight	Perform a visual inspection for contamination or deposits. Clean as required.

- Do not use the truck if there is any damage or defect.
- Contact your authorised service centre.

Climbing into and out of the truck

⚠ WARNING

Risk of injury when climbing into and out of the truck due to slipping, striking parts of the truck or becoming stuck!

If the footwell cover is very dirty or smeared with oil, there is a risk of slipping. There is a risk of hitting your head on the overhead guard post or of your clothes becoming stuck when climbing out of the truck.

- Ensure that the footwell cover is non-slip.
- Do not jump into or out of the truck.
- Ensure that you have a secure grip on the truck.

⚠ WARNING

Risk of injury when jumping out of the truck!

If your clothing or jewellery (e.g. watch, ring etc.) becomes stuck on a component while you are jumping out of the truck, this can lead to serious injuries (e.g. from falling, loss of fingers etc.). It is forbidden to jump out of the truck.

- Do not jump out of the truck.
- Do not wear jewellery at work.
- Do not wear loose-fitting workwear.

⚠ CAUTION

Components may become damaged through incorrect use!

Truck components, such as the driver's seat, steering wheel, parking brake lever etc., are not designed to be used for climbing in and out of the truck and may be damaged due to misuse.

- Only use the fittings specifically designed for the purpose of climbing into and out of the truck.

NOTE

The foot that the driver starts with when climbing into and out of the truck is crucial in ensuring this action is carried out safely. This will depend on the number of steps. Trucks with a single wheel on the front axle feature two steps. Trucks with two wheels on the front axle feature three steps.

4 Operation

Checks and tasks before daily use

Climbing in and out of trucks featuring a single wheel and two steps

When climbing into and out of the truck, use the handles (2) and (4) for support. The overhead guard post (1) can also be used for support.

Always **climb into** the truck facing forwards:

- Grip handle (2) with your left hand and hold on.
- Grip handle (4) with your right hand and hold on.
- Place your right foot on the bottom step (5).
- Place your left foot on the top step (6).
- Place your right foot into the footwell (7).
- Enter the truck and sit down on the driver's seat (3).

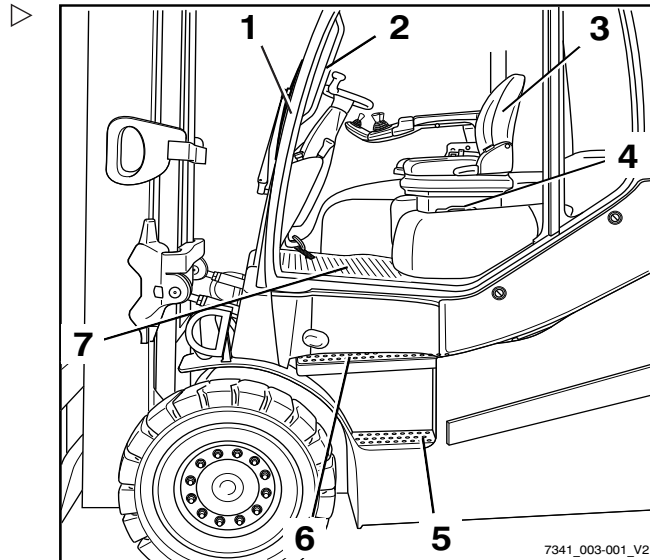

Always **climb out** of the truck backwards:

- Grip handle (2) with your left hand and hold on.
- Stand up from the driver's seat and place your left foot on the top step (6).
- Grip the handle (4) with your right hand and hold on.
- Place your right foot on the bottom step (5).
- Place your left foot on the ground and climb down from the truck.

Climbing in and out of trucks featuring two wheels and three steps

When climbing into and out of the truck, use the handles (2) and (4) for support. The overhead guard post (1) can also be used for support.

Always **climb into** the truck facing forwards:

- Grip handle (2) with your left hand and hold on.
- Grip handle (4) with your right hand and hold on.
- Place your left foot on the bottom step (5).
- Place your right foot on the middle step (6).
- Place your left foot on the top step (7).
- Place your right foot into the footwell (8).
- Enter the truck and sit down on the driver's seat (3).

Always **climb out** of the truck backwards:

- Grip handle (2) with your left hand and hold on.
- Stand up from the driver's seat and place your left foot on the top step (7).
- Grip the handle (4) with your right hand and hold on.
- Place your right foot on the middle step (6).
- Place your left foot on the bottom step (5).
- Place your right foot on the ground and climb down from the truck.

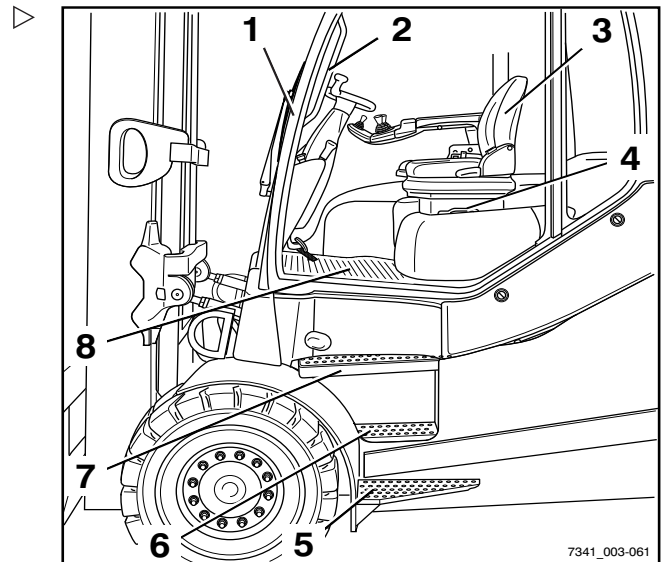

4 Operation

Checks and tasks before daily use

Shelves and cup holders

⚠ WARNING

Risk of accident!

Objects that fall into the footwell during travel as a result of steering or braking may slip between the pedals (3) and prevent them from working correctly. It may then be impossible to brake the truck.

- The storage compartment must only be used for objects that cannot fall out.
- Make sure that stored objects cannot fall from the shelves (1) when the truck is started up, steered or braked.
- Bottles with a maximum size of 0.5 l may be stored in the cup holder (2).

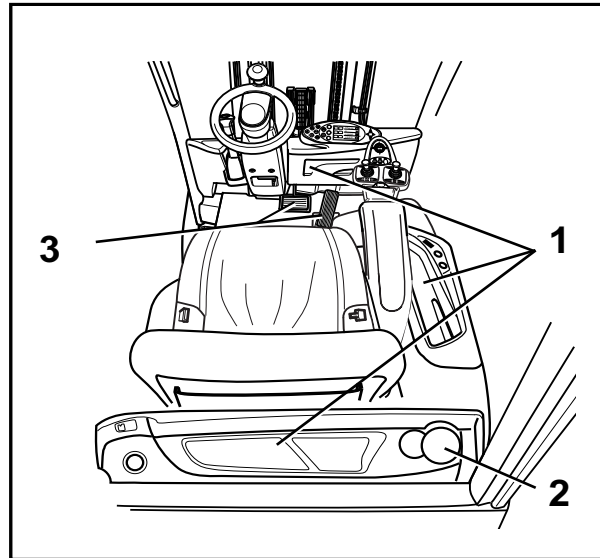

Adjusting the MSG 65/MSG 75 driver's seat

⚠ DANGER

There is a risk of accident if the seat or seat backrest shifts suddenly, which could cause the driver to move in an uncontrolled manner. This may result in unintentional actuation of the steering or operating devices and thus cause the truck or load to move in an uncontrolled fashion.

- Do not adjust the seat or seat backrest while driving
- Adjust the seat and the seat backrest so that all operating devices can be actuated safely
- Ensure that the seat and seat backrest are securely engaged

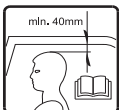

⚠ WARNING

On some equipment variants, the amount of head clearance on the truck may be restricted.

On these specific equipment variants, the distance between the head and the lower edge of the roofing sheet must be at least 40 mm.

i NOTE

If there are separate operating instructions for the seat, they must be followed.

Operation

4

Checks and tasks before daily use

⚠ WARNING

To obtain optimum seat cushioning, you must adjust the seat suspension to your own body weight. This is better for your back and protects your health.

- To prevent injury, make sure that there are no objects within the swivel area of the seat

Moving the driver's seat

- Lift and hold the lever (1)
- Push the driver's seat into the desired position.
- Release the lever.
- Ensure that the driver's seat is securely engaged.

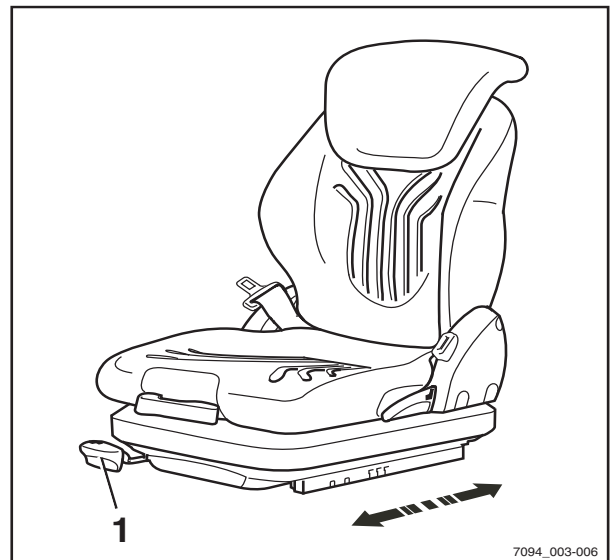

Adjusting the seat backrest

Do not put pressure on the seat backrest while engaging it.

- Lift and hold the lever (2)
- Push the seat backrest into the desired position.
- Release the lever.
- Ensure that the seat backrest is securely engaged.

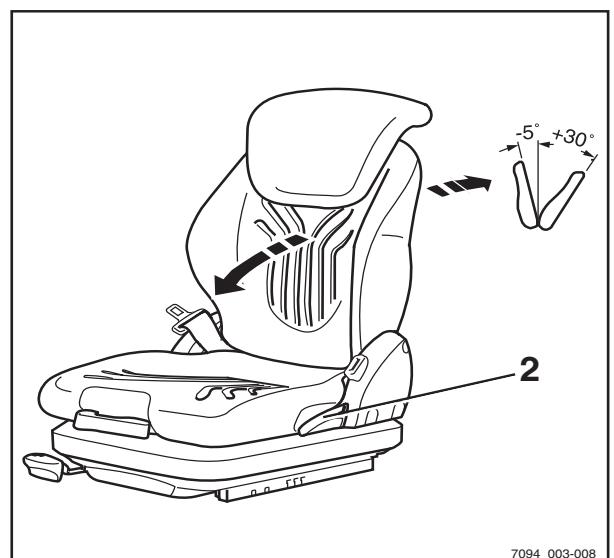

i NOTE

The backwards tilt angle of the seat backrest can be restricted by the structural condition of the truck.

4 Operation

Checks and tasks before daily use

Adjusting the seat suspension

i NOTE

The driver's seat can be adjusted to suit the weight of the individual driver. In order to achieve the best seat suspension setting, the driver should perform the adjustment whilst sitting in the seat.

i NOTE

The driver's seat MSG 65/MSG 75 is designed for people weighing between 45 kg and 170 kg.

i NOTE

The MSG 75 seat is equipped with electric air suspension that is activated using an electric switch instead of the lever (3).

- Fully extend the weight-adjusting lever (3)
- Pump it up or down to set the driver's weight.
- Return the weight adjusting lever to the central initial position before each new lift (audible click).
- Fully fold in the weight adjusting lever once adjustment is complete.

i NOTE

The driver's weight has been selected correctly when the arrow (4) is in the centre of the inspection window. If the seat does not move any further when you pump the weight adjusting lever, the minimum or maximum weight setting has been reached.

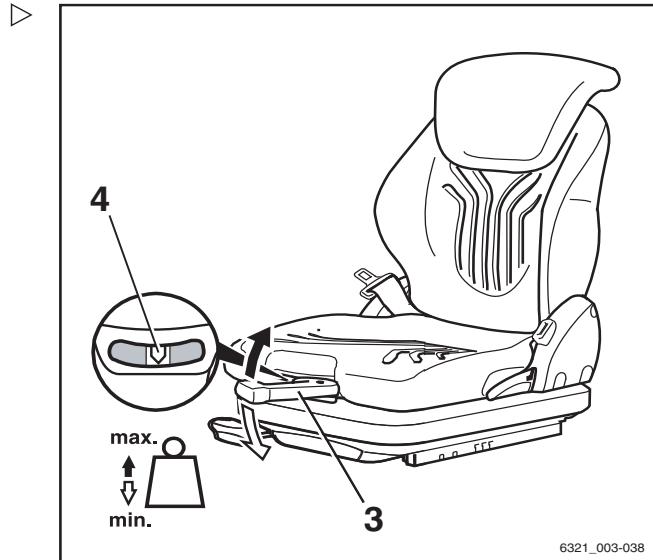

Operation

4

Checks and tasks before daily use

Adjusting the lumbar support (variant) ▷

NOTE

The lumbar support can be adjusted to suit the contours of the individual driver's spine. Adjusting the lumbar support moves a convex support cushion into the upper or lower part of the backrest.

- Turn the turning knob (5) up or down until the lumbar support is in the desired position

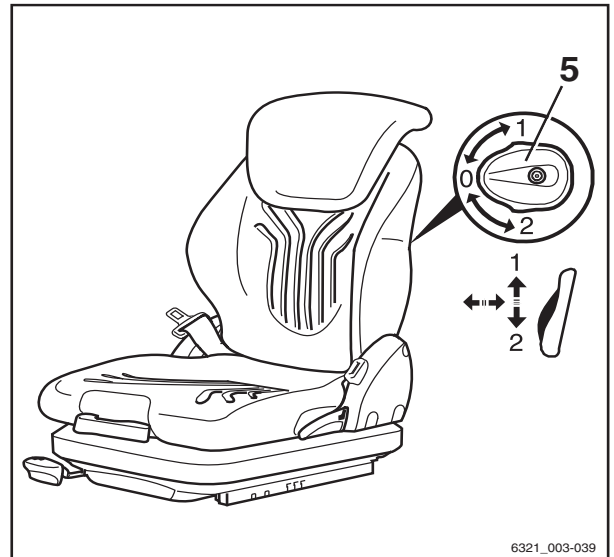

Adjusting the backrest extension (variant) ▷

- Adjust the backrest extension (6) by pulling it out or pushing it into the desired position.

To remove the backrest extension, move it past the end stop by jolting it upwards.

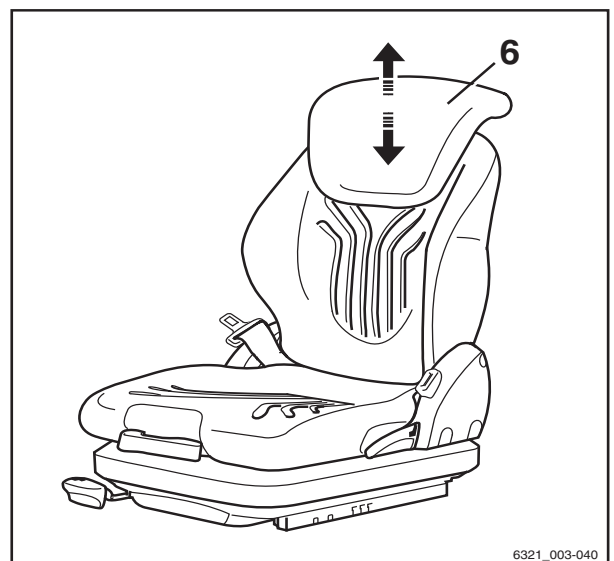

4 Operation

Checks and tasks before daily use

Switching the seat heater (variant) on and off

i NOTE

The seat heater only functions if the seat contact switch is active, i.e. when the driver is sitting on the driver's seat.

- Switch the seat heater (7) on or off using the switch.

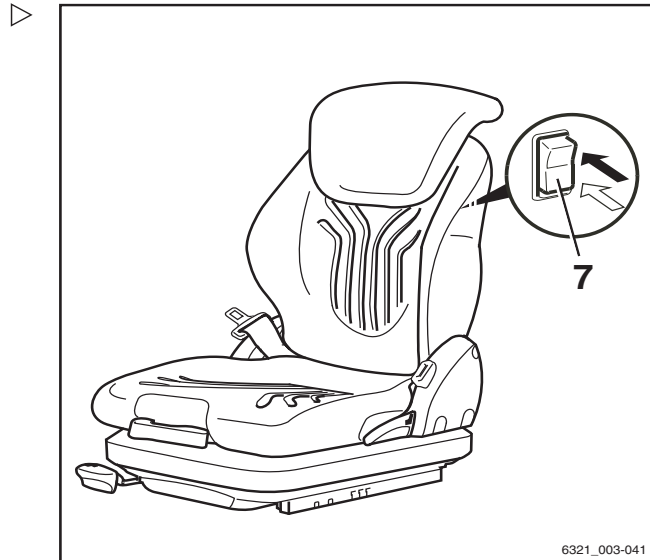

Adjusting the armrest

⚠ DANGER

There is a risk of accident if the armrest lowers suddenly, causing the driver to move in an uncontrolled manner. This can result in unintentional actuation of the steering or the operating devices and thus cause uncontrolled movements of the truck or load.

- Do not adjust the armrest while driving.
- Adjust the armrest so that all operating devices can be actuated safely.
- Ensure that the armrest is securely tightened.

Operation

4

Checks and tasks before daily use

Adjusting the length of the armrest

- Release the star-grip handle (1) by turning it anti-clockwise.
- Shift the armrest (2) into the desired position.
- Tighten the star-grip handle by turning it clockwise.
- Check that the armrest is firmly attached.

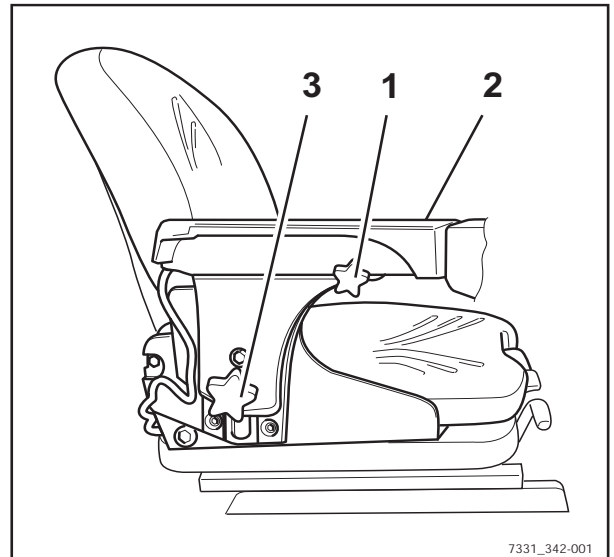

7331_342-001

Adjusting the height of the armrest

- Release hand wheel (3) by turning it anti-clockwise.
- Shift the armrest (2) into the desired position.
- Tighten the hand wheel by turning it clockwise.
- Check that the armrest is firmly attached.

Adjusting the steering column



⚠ DANGER

Risk of accidents!

Adjusting the steering column during travel may cause the truck to career out of control.

- Adjust the steering column only when the truck is at a standstill.
- Ensure that the steering column is engaged.

- Press down and hold the lever (2) for steering column adjustment.
- Position the steering column (1) and release the lever.

When the steering column engages, the lever snaps back to the initial position.

- Gently push and pull on the steering column to make sure that the steering column is engaged.

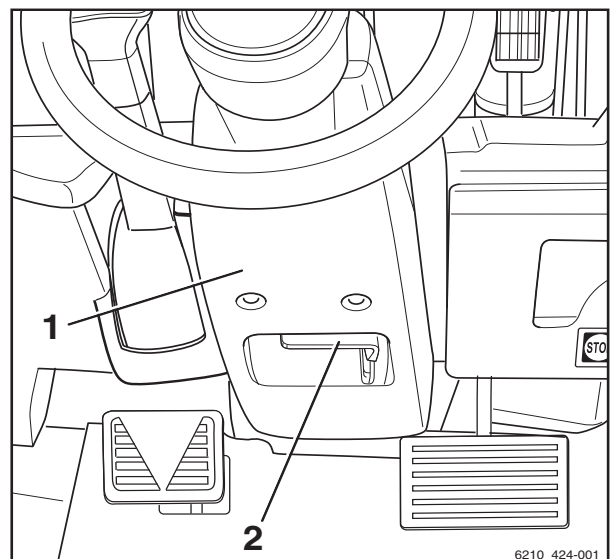

6210_424-001

4 Operation

Checks and tasks before daily use

Unlocking the emergency off switch ▷

- Pull the emergency off switch (1) until it is unlocked.

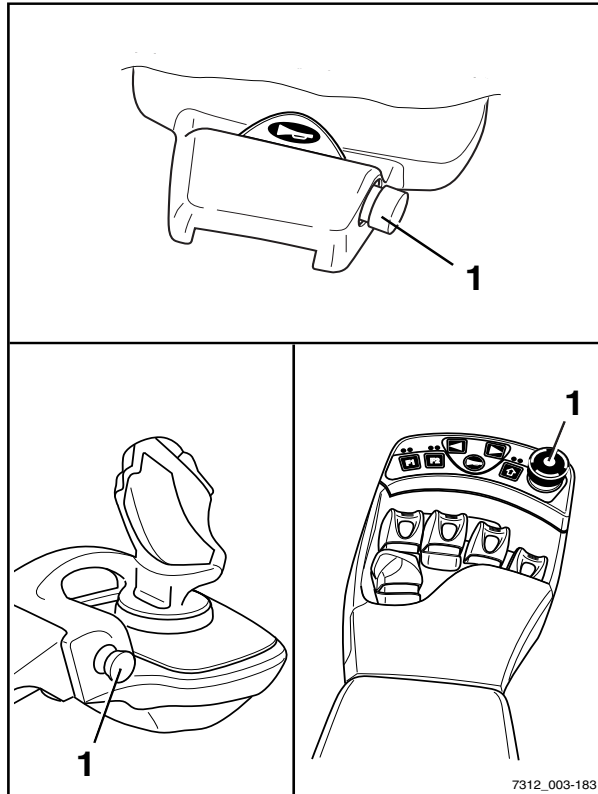

Operating the signal horn ▷

i NOTE

The signal horn is used to warn people against imminent danger or to announce your intention to overtake.

- Push the signal horn button (1).

The signal horn sounds.

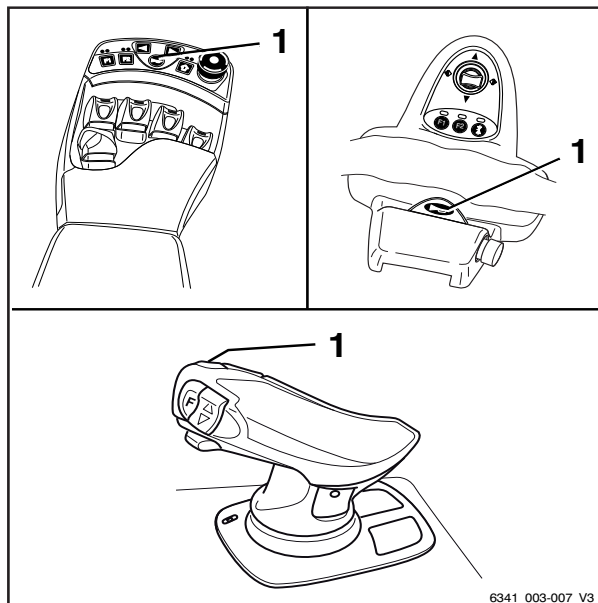

Seat belt



⚠ DANGER

Even when using an approved restraint system, there is some residual risk that the driver might be injured if the truck tips over.

This risk of injury can be reduced through the combined use of the restraint system and the seat belt.

In addition, the seat belt protects against the consequences of rear-end collisions and falling off a ramp.

- We therefore recommend that you also use the seat belt.

⚠ DANGER

Only bracket doors (variant) or the driver's cab (variant) with closed, fixed doors constitute a driver restraint system. Plastic doors (weather protection) do not constitute a restraint system!

If you need to open or remove the doors, you must use an alternative suitable restraint system (e.g. a seat belt).

Fastening the seat belt

⚠ DANGER

Risk to life when driving without a seat belt!

If the truck tips over or crashes into an obstacle and the driver is not wearing the seat belt, the driver may be thrown from the truck. The driver could slide under the truck or collide with an obstacle.

There is a risk of fatal injury!

- Fasten the seat belt before every trip.
- Do not twist the seat belt when fastening it.
- Only use the seat belt to secure one person.
- Have any malfunctions repaired by the authorised service centre.

i NOTE

The buckle has a buckle switch (variant). In the event of an operating error or malfunction, the message SAFETY BELT appears in the display and operating unit, see the chapter entitled "Display messages".

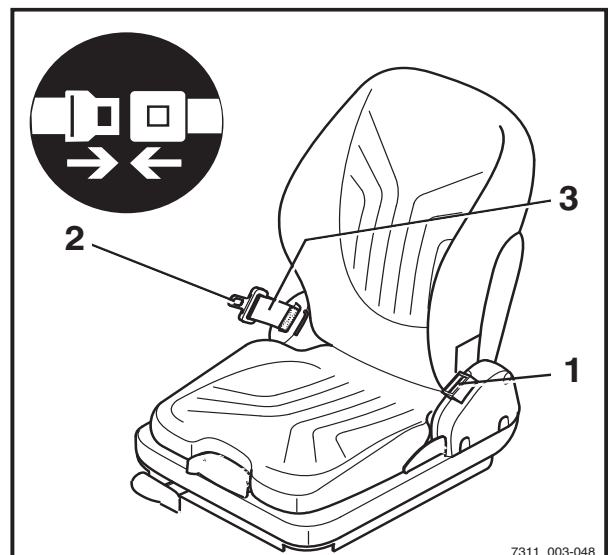

4

Operation

Checks and tasks before daily use

- Pull the seat belt (3) out of the belt retractor without jerking and fasten closely around the body over the thighs.

i NOTE

Sit as far back as possible so that your back is leaning against the seat backrest. The automatic blocking mechanism permits sufficient freedom of movement on the seat.

- Click the belt tongue (2) into buckle (1).
- Check tension of the seat belt. It should be close to the body.

Fastening on a steep slope

The automatic blocking mechanism prevents the belt from being extended whenever the truck is on a steep gradient. It is not possible to pull the seat belt any further out of the belt retractor.

- Move away carefully on the slope.
- Fasten the seat belt.

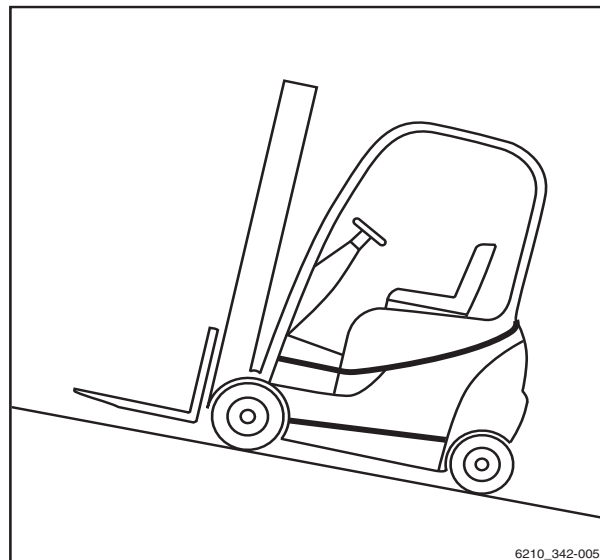

6210_342-005

Operation

4

Checks and tasks before daily use

Releasing the seat belt

- Push the red button (4) on the buckle (1).
- Manually guide the belt tongue slowly back to the retractor.

NOTE

Do not allow the seat belt to retract too quickly. The automatic blocking mechanism may be triggered if the belt tongue strikes the housing. It will then no longer be possible to pull the seat belt out with the usual force.

- Using increased force, pull the seat belt around 10-15 mm out of the retractor to disengage the blocking mechanism.
- Slowly allow the seat belt to retract again.
- Protect the seat belt from dirt (for example, by covering it).

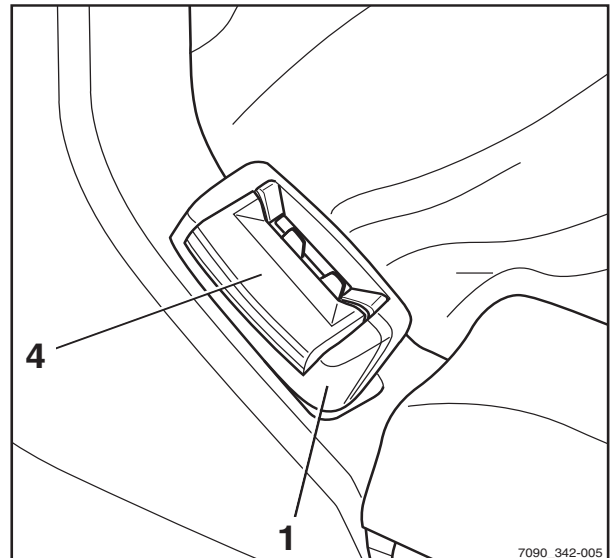

Malfunction due to cold

- If the buckle or belt retractor is frozen, thaw them out and dry them thoroughly to prevent recurrence.

CAUTION

The seat belt may be damaged by heat!

Do not subject the buckle or belt retractor to excessive heat when thawing.

- Do not use air warmer than 60°C when thawing.

4

Operation

Checks and tasks before daily use

Using the driver's cab

⚠ DANGER

Risk of fatal injury in the event of falling from the truck if it tips over!

In order to prevent the driver from sliding underneath the truck and being crushed if the truck tips over, a restraint system must be in place and must be used. This will prevent the driver from falling out of the truck if it tips over. The driver's cab constitutes a driver restraint system only if the cab door is sturdy and closed. Fabric-covered cabs (variant) with doors made of plastic or canvas do not constitute a driver restraint system and offer no protection from the consequences of the truck tipping over!

- Close the cab door before operation.
- If the door is open or has been removed, use a comparably secure restraint system.
- We recommend that you always use the seat belt.

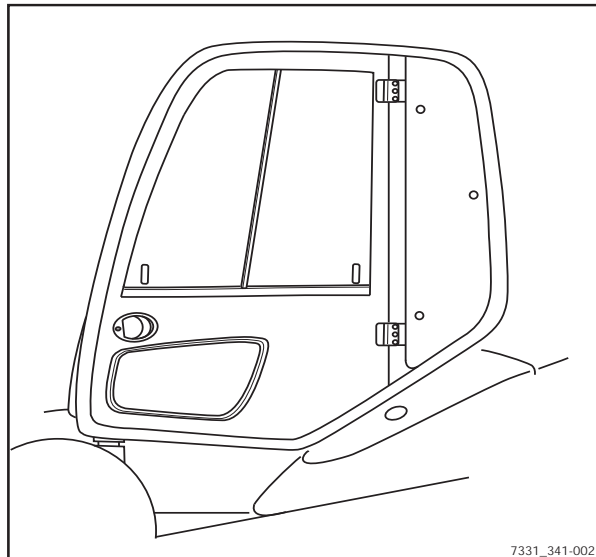

Checking the brake system for correct function

⚠ DANGER

Risk of accident due to failure of the brake system!

If the brake system fails, the truck will be insufficiently braked or will not be braked at all.

- Do not operate the truck with a defective brake system.

Checking the service brake

- Release the parking brake.
- Depress the brake pedal (1).

There must be a slight pedal clearance and then a noticeable pressure point at the brake.

- Accelerate the unladen truck in a clear area.
- Depress the brake pedal firmly.

The truck must decelerate noticeably.

Checking the parking brake

On a gradient or a ramp:



⚠ DANGER

Risk to life if the truck rolls away!

The truck could run people over if the parking brake is not applied.

- Do not exit the truck during the following check.

- Stop the truck on a steep gradient (e.g. a ramp) and actuate the parking brake.

The parking brake must hold the truck on the incline.

If the truck rolls back despite the parking brake being applied:

- Secure the truck using the service brake.
- Secure the truck with chocks so that the truck does not roll away.
- Contact the authorised service centre.

On level ground:

⚠ WARNING

Risk of accident!

The truck may decelerate abruptly.

- Fasten the seat belt.
- Activate the available restraint systems.

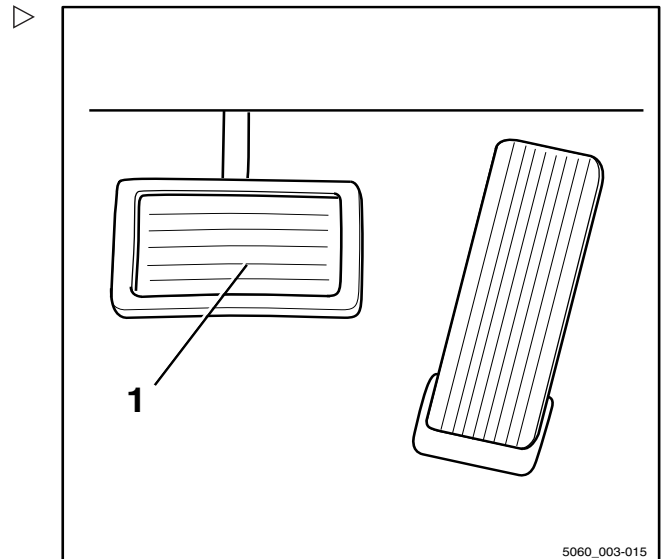

4

Operation

Checks and tasks before daily use

⚠ WARNING

No electric braking assistance is available when the emergency off switch is actuated!

Actuating the emergency off switch will de-energise the entire electrical system. The regenerative brake will not be available.

⚠ CAUTION

No power steering is available when the emergency off switch is actuated!

The truck is equipped with a hydraulic power steering system. When the emergency off switch is actuated, the hydraulic system is completely shut down. Steering forces are increased by the remaining emergency steering function.

- Steer with a higher level of force.
- Find a sufficiently large, open area in which nobody will be obstructed.
- Accelerate the truck to walking speed.
- Push the emergency off switch (1).
- Actuate the parking brake.

The truck must decelerate and remain stationary.

If the truck only coasts and does not decelerate or decelerates only slightly:

- Secure the truck using the service brake.
- Secure the truck with chocks so that the truck does not roll away.
- Contact the authorised service centre.

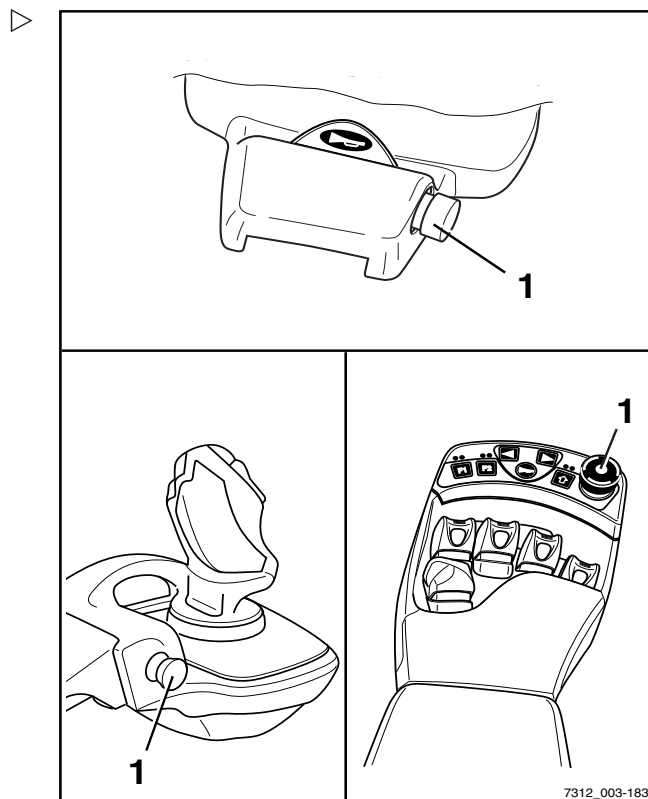

Operation

4

Checks and tasks before daily use

Checking the regenerative brake

⚠ DANGER

Risk of accident due to reduced braking power!

The regenerative brake may not be sufficient for emergency braking.

- Always actuate the brake pedal (1) for emergency braking.

If the driving speed is restricted or if the opposite drive direction is selected, the truck brakes electrically.

- Release the accelerator pedal (2).
- The truck must brake to a standstill.

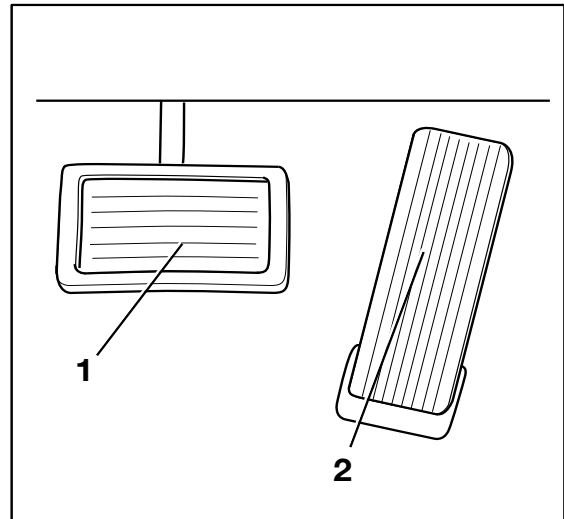

Checking the steering system for correct function

⚠ DANGER

If the hydraulics fail, there is a risk of accident as the steering characteristics have changed.

- Do not operate the truck if it has a defective steering system.
- Operate steering wheel (1). The steering play while stationary must not be more than two finger widths.

i NOTE

If the truck is switched on with the steering wheel turned, the maximum driving speed is limited. Travel speed limitation is removed as soon as the steering wheel is moved out of a cornering position into the straight-ahead position. This requires a change in steering angle of about half a revolution.

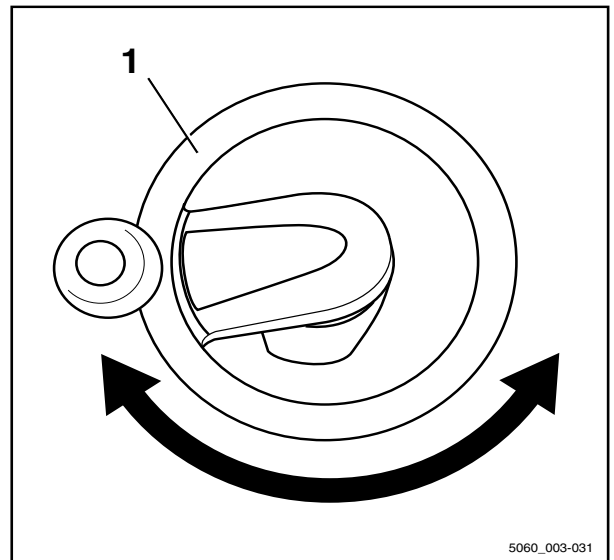

5060_003-031

Checks and tasks before daily use

Checking the emergency off function

⚠ WARNING

There is no electric braking assistance when the emergency off switch is actuated!

Actuating the emergency off switch will de-energise the entire electrical system. The truck will not be held on a slope by the electric brake.

- Brake the truck by depressing the brake pedal.

⚠ CAUTION

There is no power steering when the emergency off switch is actuated!

The truck is equipped with a hydraulic power steering system. When the emergency off switch is actuated, the hydraulic system is completely shut down. Steering forces are increased by the remaining emergency steering function.

- Steer with a higher level of force.

- Slowly drive the truck forwards.

- Press the emergency off switch (1).

The truck will roll to a stop.

- Brake the truck to a standstill by depressing the brake pedal.

- Pull out the emergency off switch (1).

The knob is unlocked and pops out. The truck performs an internal self-test and is then ready for operation again.

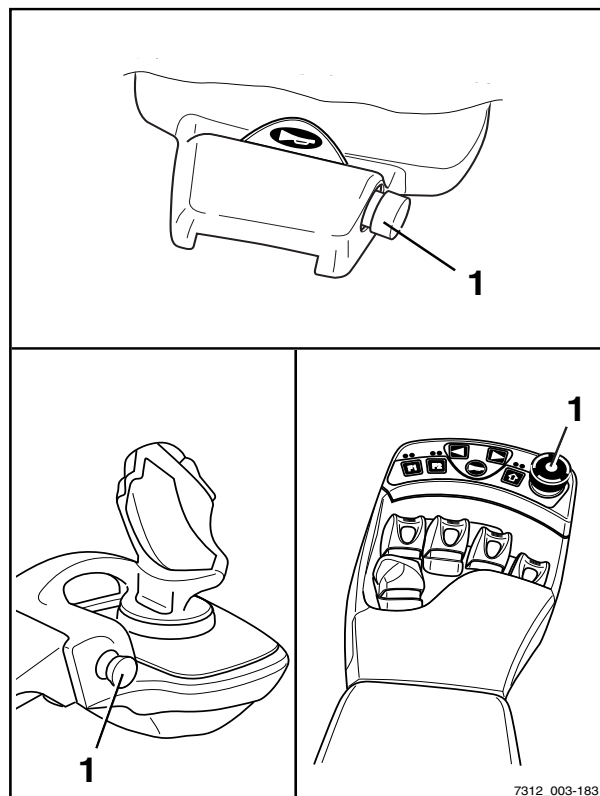

Checking the vertical lift mast position (variant) for correct function

NOTE

The function check of the lift mast vertical position (variant) must be carried out every time a truck is commissioned.

- Press the Softkey  (1).

The comfort feature "lift mast vertical position" is switched on. The symbol  (2) is displayed.

- Tilt the lift mast backwards.

The lift mast must tilt back fully and move gently as far as the end stop.

- Tilt the lift mast forward.

The lift mast must tilt forwards and stop in the vertical position.

- Release the operating device to tilt and actuate again.

The lift mast must tilt forwards fully and move gently as far as the end stop.

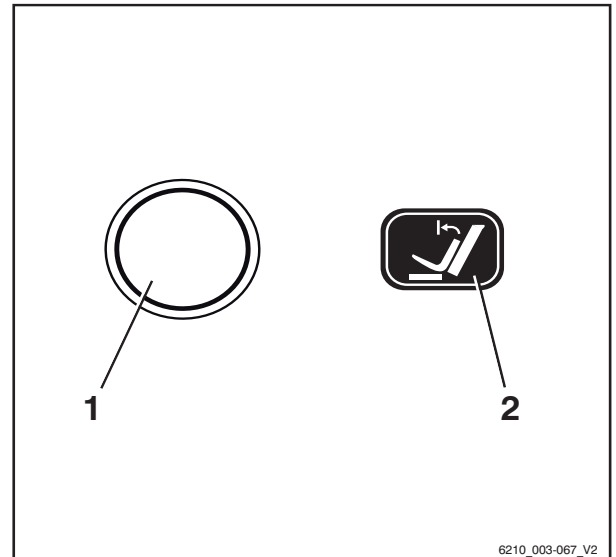

Zero adjustment of the load measurement (variant)

NOTE

A zero adjustment must be carried out in order to guarantee the accuracy of the load measurement (variant) at all times. Zero adjustment is required

- Before daily use
- after changing the fork arms
- after fitting or changing attachments.

NOTE

Accurate zero adjustment is only possible if the fork is not carrying a load. Do not take up a load yet.

4 Operation

Checks and tasks before daily use

i NOTE

Accurate zero adjustment is only possible within the first lifting stage of the lift mast. When carrying out the zero adjustment, do not raise the fork more than 800 mm above the ground.

i NOTE

The way in which the lifting system is operated depends on the operating devices included in the truck's equipment; see the chapter entitled "Lifting system operating devices".

- Set lift mast to vertical.
- Raise the fork to a height of 300-800 mm.
- Press the Softkey (1).

The zero adjustment of the load measurement is switched on. The symbol is displayed. The message LOWER FORKS appears on the display.

i NOTE

During the following process, the fork carriage must be lowered slightly and then stopped abruptly. While doing so, the fork must not touch the ground, otherwise the zero adjustment will not be accurate. To stop the lowering procedure quickly, release the operating device for lowering so that it jumps into the zero position.

- Lower the fork carriage slightly and release the operating device.

When the zero adjustment has been carried out correctly, the value "0 kg" appears on the display.

- The zero adjustment of the load measurement is completed. The symbol (2) is displayed.

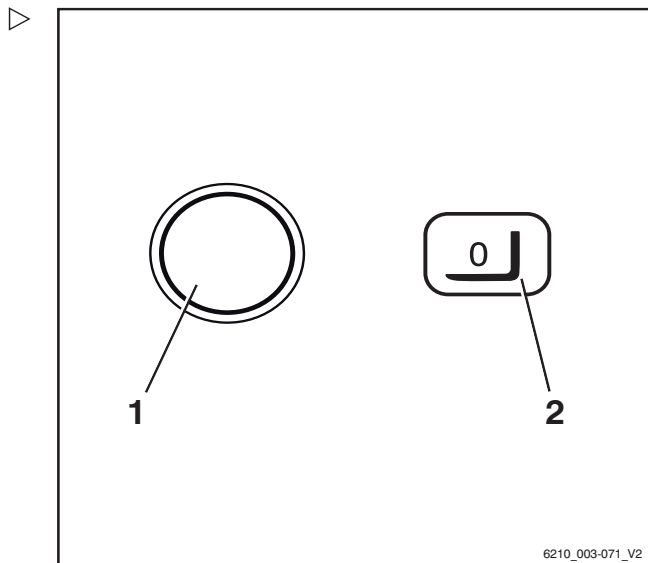

6210_003-071_V2

Switching on

Switching on the key switch

⚠ WARNING

Before switching on the key switch, all tests and operations prior to commissioning must be performed without any defects being detected.

- Carry out checks and operations before commissioning.
- Do not operate the truck if defects have been detected; contact the authorised service centre.

NOTE

When the truck is switched on, the maximum driving speed is restricted. The driving speed limitation is disabled as soon as the truck is steered out of cornering to drive in a straight line. To do this, rotate the steering wheel by approximately half a turn.

- Insert switch key (1) into the key switch and turn to position "I". ▷

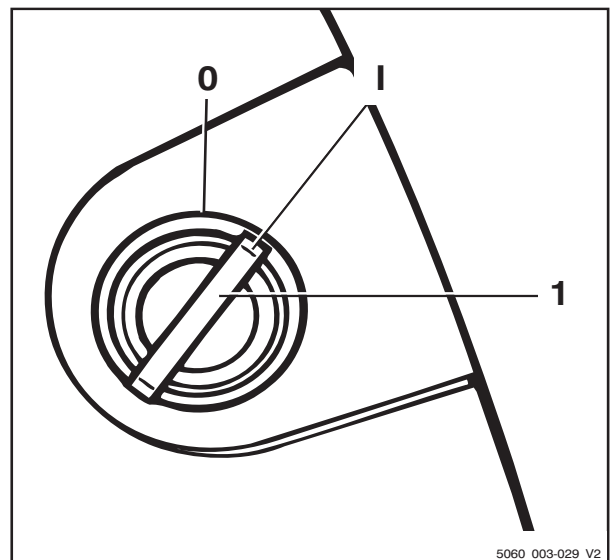

4 Operation

Switching on

This initiates a self-test. All lamps in the drive direction and turn indicator displays light up briefly.

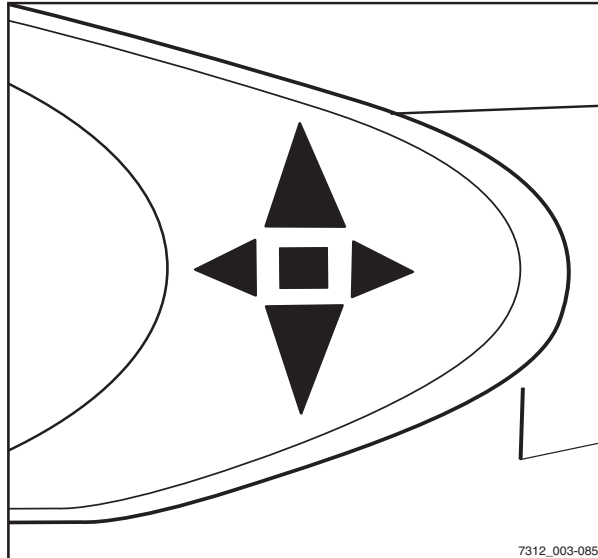

7312_003-085

When the key switch is switched on, the display shows the welcome screen in the set language until the truck controller has fully started up.

If the truck is ready for operation, the standard displays are shown.

If the truck is equipped with the "access authorisation with PIN code" variant, the display initially changes to the input menu for access authorisation.



Standard display elements

- 1 **Battery charge**
The available battery capacity is shown in the display field.
- 2 **Drive program**
The current traction program (1–5) appears on the display.
- 3 **Power rating**
The average power consumption and consumption trends are shown in the display field.
- 4 **Time**
The current time appears in the display field.

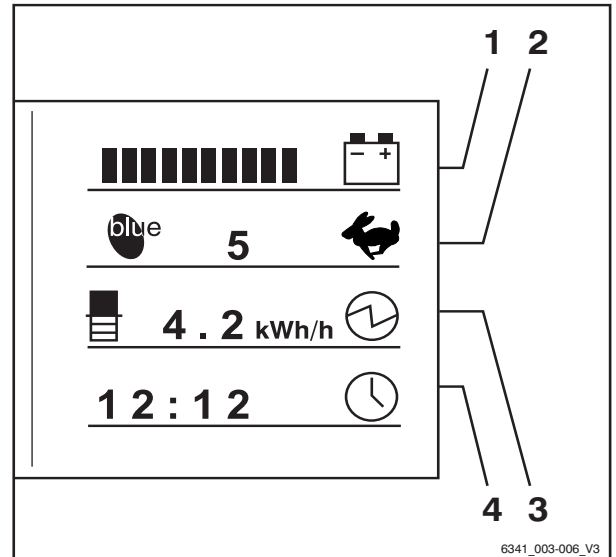

6341_003-006_V3

NOTE

After connecting the battery, the correct charging state may not be displayed until the battery is placed under load in the form of driving or lifting operations.

Additional information may appear on the display.

- If malfunctions occur, refer to the information in the chapter entitled "Display messages".

Access authorisation with PIN code (variant)

Description

Trucks equipped with the "Access authorisation with PIN code" variant are protected against unauthorised use by a five-digit driver PIN. Up to fifty different driver PINs can be defined so that the same truck can be used by different drivers, each with their own driver PIN.

NOTE

The driver PINs are defined in a truck control unit menu that can only be accessed by persons with the corresponding access authorisation, e.g. fleet managers.

Switching on

Once the key switch has been switched on, the input menu for the driver PIN appears on the display and operating unit screen. All of the truck's functions (driving, hydraulics, additional electrical installations and the display and operating unit displays) are blocked. The function of the hazard warning system (variant) is guaranteed. Enter the five-digit driver PIN (possible entries from 00000 to 99999) to enable the blocked functions. Once the correct driver PIN has been entered, the standard displays are shown. All of the truck functions are available.

The access authorisation can be configured in such a way that the driver PIN has to be re-entered each time the driver steps off the truck, in order for the truck to be operated again.

- Contact the authorised service centre on this matter.

The first driver PIN is preset to "11111" at the factory. All others are preset to "0xFFFF" but have no function as the highest valid driver PIN is "99999". Persons with the appropriate access authorisation, e.g. fleet managers, can change the driver PINs in the corresponding menu.

NOTE

When first commissioning the truck, we recommend you change the access authorisation set at the factory. This is the only way to guarantee that the driver PIN is only known to persons with corresponding access authorisation.

The driver PINs are stored in the truck control unit. These are still available if the display and operating unit has been changed. The authorised service centre can use a diagnostic device to read out the driver PIN and, if necessary, restore the factory default driver PIN.

ACCESS CODE input menu

The driver enters the five-digit driver PIN (00000 to 99999) in this input menu.

The driver PIN is entered using the buttons or Softkeys (1). The digits entered for the driver PIN (2) are not visible but are represented by circles instead. If the driver PIN entered is correct, the familiar screen appears with the standard display, and all truck functions are available.

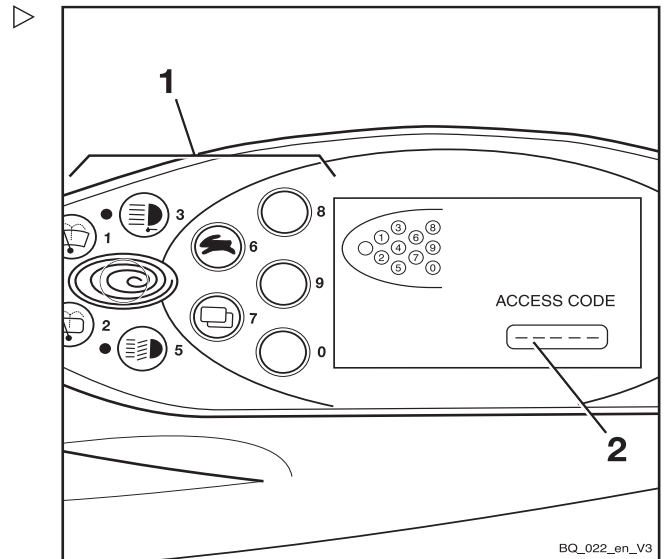

If an incorrect driver PIN is entered, the message **INVALID** appears for a short time. When the message goes out, the driver PIN can be re-entered.

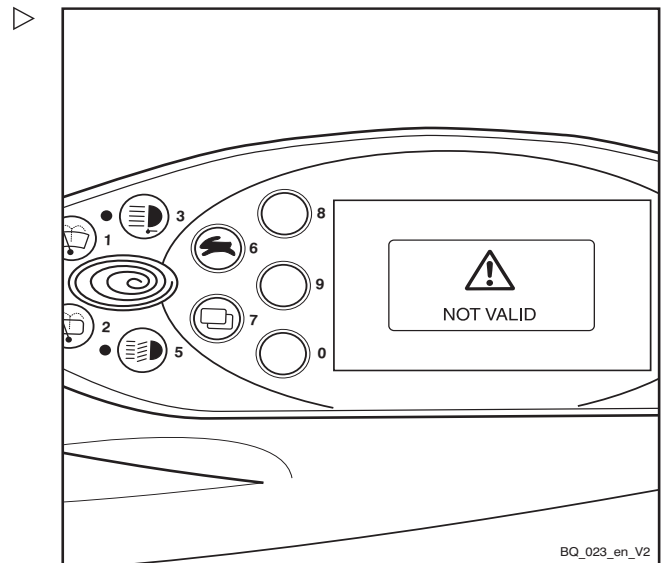

4 Operation

Switching on

After three invalid entry attempts, the message CODE DENIED appears. The input is then locked for five minutes before another attempt can be made.

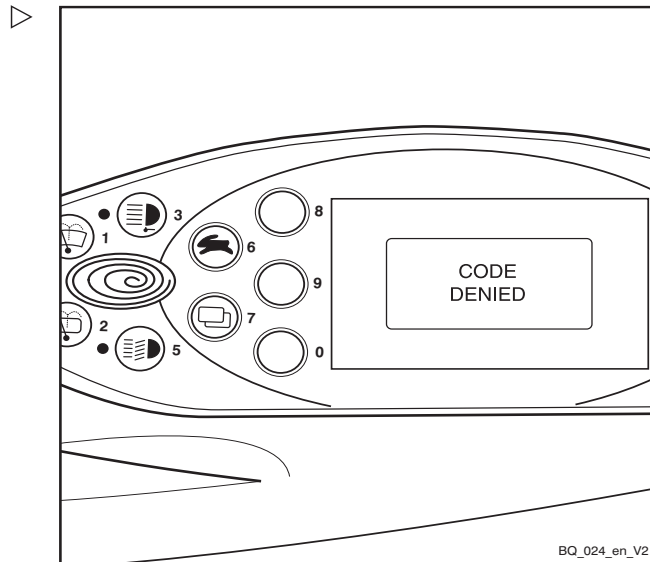

Defining the driver PIN

i NOTE

The driver PINs can be defined only by persons with the appropriate access authorisation, e.g. fleet managers. To set the driver PIN, the fleet manager must access the configuration menu. The configuration menu is password-protected. After entering the password, the fleet manager can configure general settings for the truck. To change the password, see the chapter entitled "Changing the password".

- Push the drive program selection button (1) and the menu change button (2) at the same time.

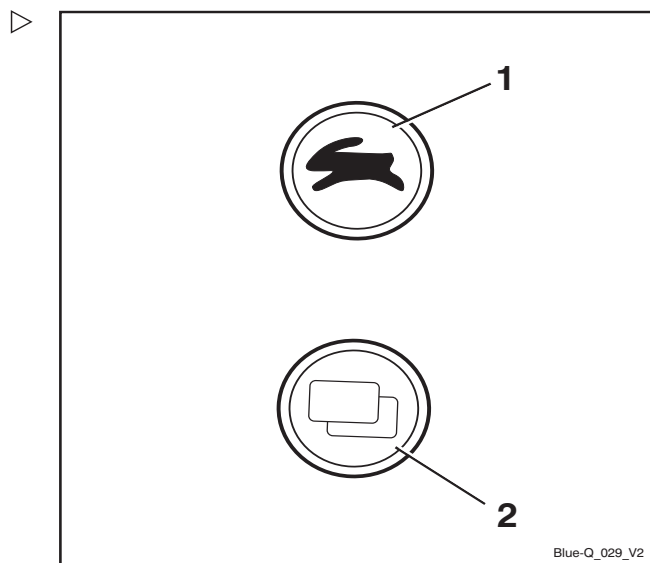

Operation

4

Switching on

PASSWORD appears in the display.

- Enter the four-digit password (factory default: 2777) using the buttons (1).
- Confirm the input using Softkey  (2).

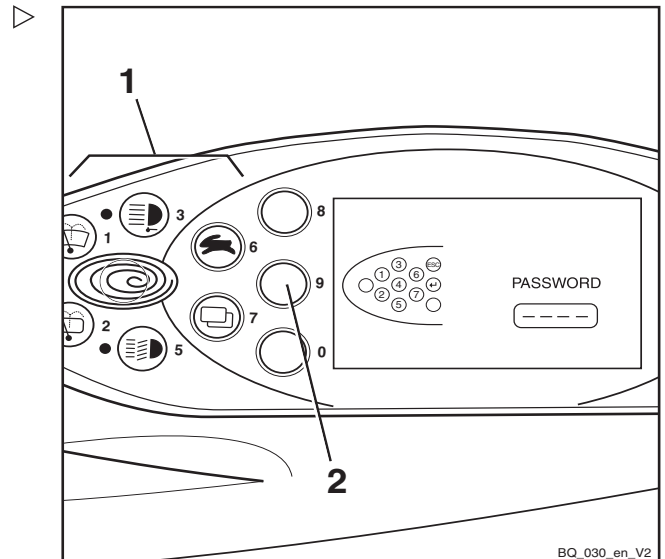

CONFIGURATION appears in the display.

- Use the drive program selection button (1) and the menu change button (3) to select the ACCESS CODE menu.
- Confirm your selection using Softkey  (2).

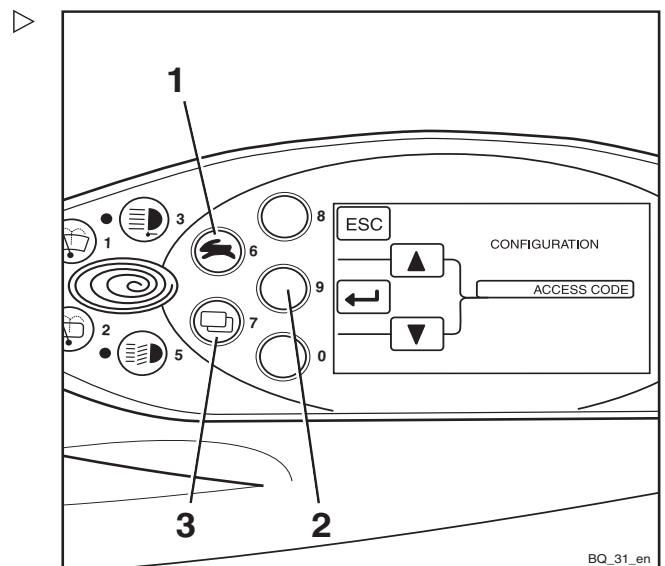

4 Operation

Switching on

Selecting the driver PIN

In the ACCESS CODE menu, there are fifty possible driver PINs to choose from.

The digit sequences can be set or changed in the NEW CODE submenu.

Once the ACCESS CODE menu has been accessed, the CODE selection field (2) contains the number 1. The first of the fifty driver PINs can now be defined.

- Use the drive program selection button (1) and the menu change button (4) to select the desired driver PIN (1 to 50).
- Confirm your selection using Softkey  (3).

NEW CODE appears in the display.

- Enter the desired driver PIN using the buttons or Softkeys (5).

The digits entered do not appear in the display. Instead they are represented by circles in the NEW CODE field (6).

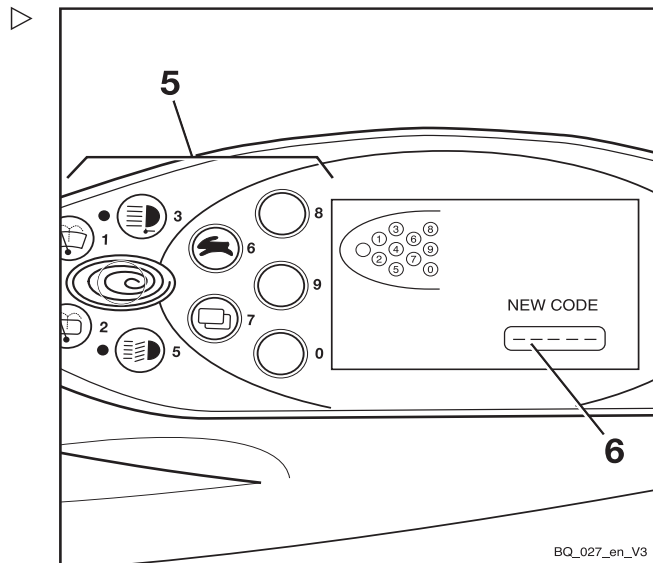
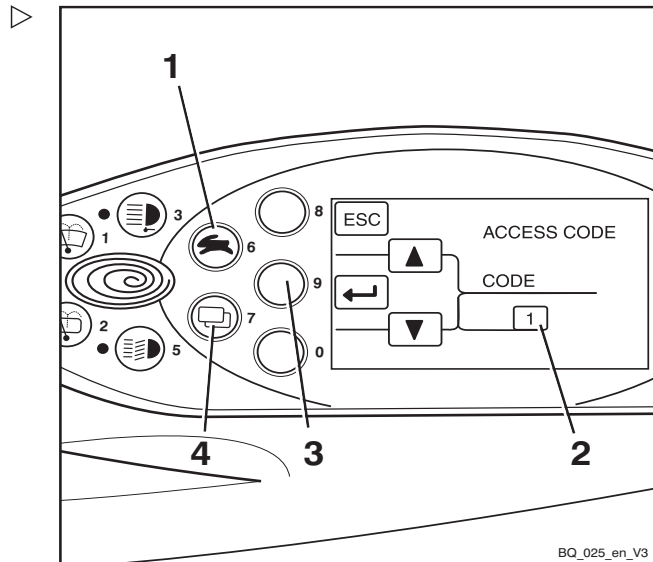

Operation

4

Switching on

CONFIRM appears in the display.

The CONFIRM submenu is used to confirm the new driver PIN.

- Enter the new driver PIN for a second time in the CONFIRM field (8) using the buttons or Softkeys (7).

If the entry matches the new driver PIN previously entered, the system will accept the new driver PIN once the last digit has been entered. The display switches back to the ACCESS CODE menu.

Another driver PIN can be defined here.

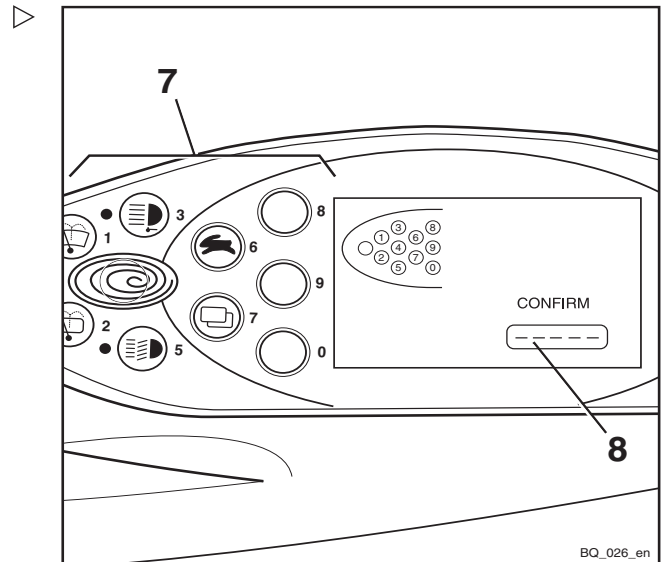

If the driver PIN entered in the CONFIRM submenu does not match the driver PIN entered previously in the NEW CODE submenu, the message INVALID will appear.

The message will then disappear after a short time. The new driver PIN can be entered in the CONFIRM submenu for further confirmation.

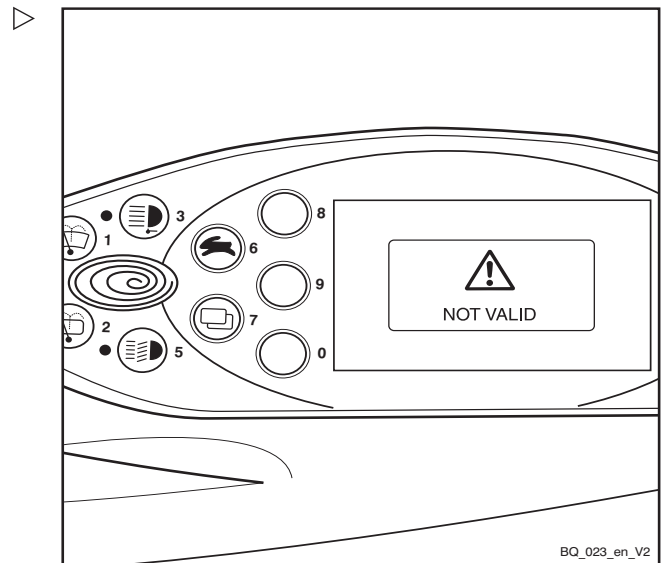

4 Operation

Switching on

After three incorrect entries, the CODE DENIED message appears.

The display switches back to the ACCESS CODE menu. The desired driver PIN must be re-defined.

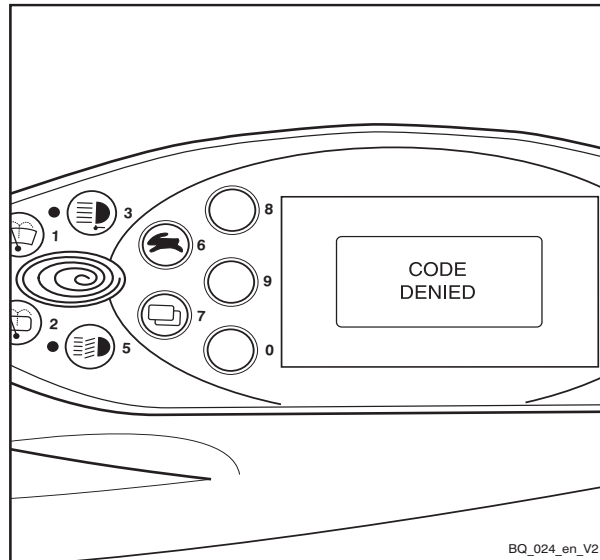

Changing the password

It is recommended that you change the factory default password.



The password can only be changed when the parking brake is applied.

- Push the drive program selection button (1) and the menu change button (2) at the same time.

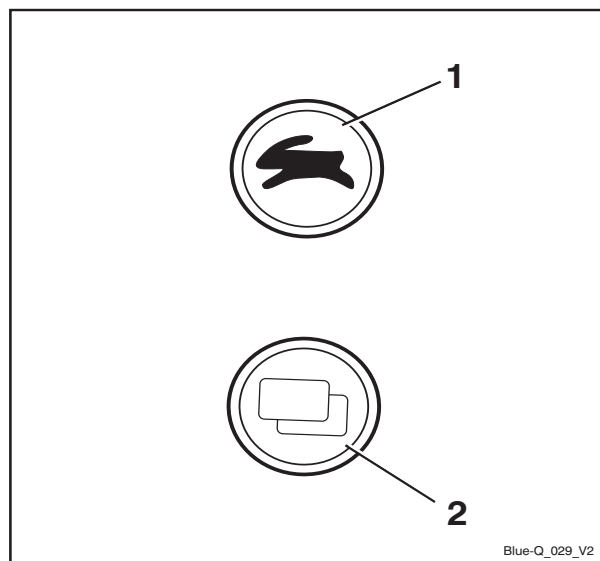

Operation

4

Switching on

PASSWORD appears in the display.

- Enter the current password using the buttons (1).
- Confirm the input using Softkey (2).

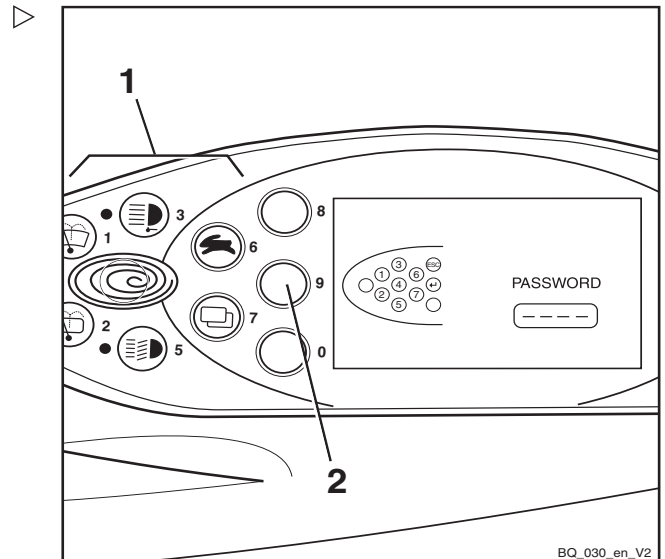

CONFIGURATION appears in the display.

- Use the drive program selection button (1) and the menu change button (3) to select the PASSWORD menu.
- Confirm your selection using Softkey (2).

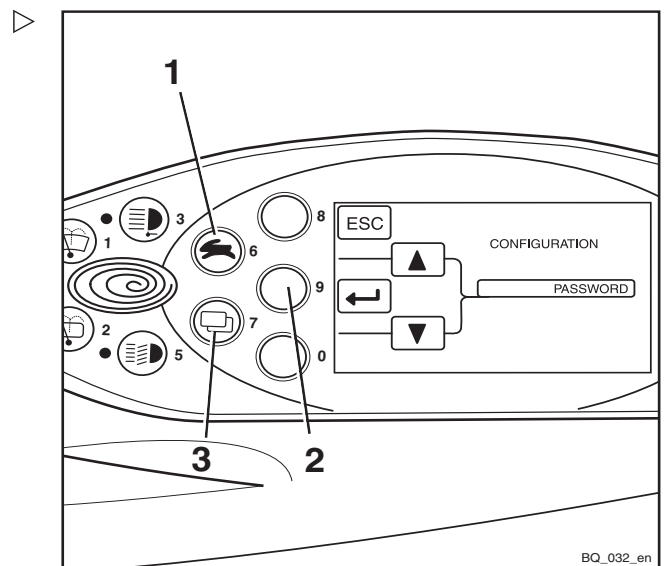

4 Operation

Switching on

PASSWORD/PASSWORD LEVEL appears in the display. ▷

- Use the drive program selection button (1) and the menu change button (4) to select the desired PASSWORD LEVEL (2).
- Confirm your selection using Soft-key (3).

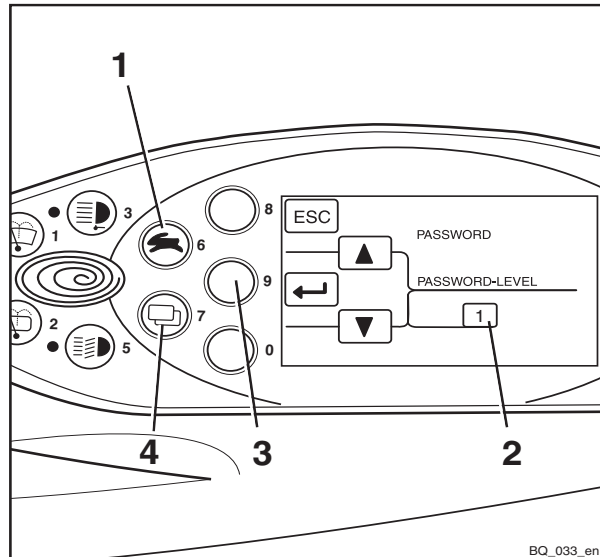

NEW CODE appears in the display. ▷

The four-digit password can be entered using the buttons (1).

⚠ CAUTION

Do not enter the password 1777!
If this password is entered, the configuration options for the fleet manager are restricted to driver authorisations and cannot be reset independently. The authorisations can only be reset by the authorised service centre!

- Enter the new desired password using the buttons (1).

The digits entered are shown in plain text in the NEW CODE field (4).

- Confirm your selection using Soft-key (3).

In the NEW CODE field, - ?? - appears briefly. The new password is confirmed.

- Press Softkey (2) to correct the new password.

The display switches back to PASS - WORD/PASSWORD LEVEL.

- Repeat the process steps from PASS - WORD/PASSWORD LEVEL.
- To exit the configuration menu, press Softkey (2) repeatedly until the standard display appears.

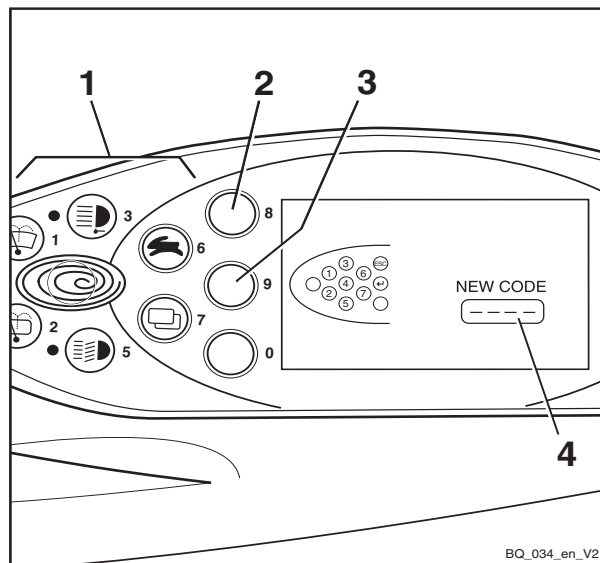

Operating the display and operating unit

Indicators

Standard displays

In the factory setting, the following indicators can be seen in the display and operating unit:

1 **Battery charge** 

Displays the available battery capacity as a segmented bar graph in 10% increments.

Approx. every 10 seconds, the display switches from showing the battery charge to the remaining operating time.

If a different drive program or a different drive mode (e.g. Blue-Q) is selected, the system immediately recalculates the remaining operating time and indicates for how long the truck can be driven if the operating situation of the last 30 minutes is maintained.

2 **Drive program** 

Displays the number of the selected drive program. To change the drive program, refer to the section entitled "Setting the drive program".

The Blue-Q icon  appears when the Blue-Q function is switched on; refer to the section entitled "Blue-Q efficiency mode".

3 **Power rating** 

The power rating indicator shows the average energy consumption over the last 30 minutes in kilowatts (kW).

Trends relating to the current energy consumption are displayed as a vertical bar graph . The percentage change in each bar is shown in the table under "Power trends indicator" below.

4 **Time** 

Displays the current time digitally in hours and minutes. The time can be adjusted; see the chapter entitled "Setting the time".

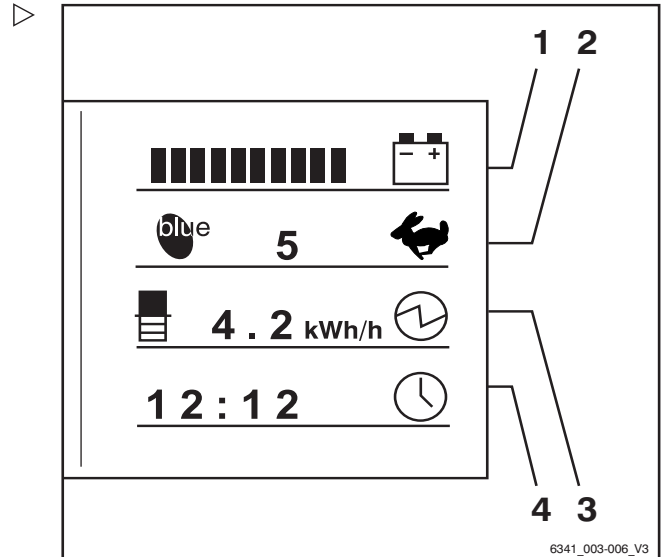



Operating the display and operating unit

⚠ CAUTION

Deep discharges shorten the service life of the battery.

If no bar is shown (0% of the available battery capacity, i.e. around 20% of the nominal capacity), deep discharge begins.

- Deep discharge (no bar on the display) must be avoided.
- Cease work with the truck immediately.
- Charge the batteries immediately.

i NOTE

To prevent deep discharge, certain restrictions (variant) can be activated (e.g. slow lifting). Consult the authorised service centre on this matter.

Power trends indicator

Symbol	Energy consumption trend
	Significant increase (> 50%)
	Increase (up to 50%)
	Slight increase (up to 30%)
	No change
	Slight decrease (up to -30%)
	Decrease (up to -50%)
	Significant decrease (> -50%)

Additional indicators

5 Menu change button

When the menu change button is pressed, the following additional indicators appear:

6 "Service in" display

Displays the remaining time in operating hours until the next maintenance operation is due according to the maintenance schedule in the maintenance instructions. Contact the authorised service centre in good time.

7 Operating hours

Displays the total operating hours completed by the truck. The hour meter starts running as soon as the truck is driven or the working hydraulics are actuated.

8 Total distance

Displays the total distance driven in kilometres.

9 Daily kilometres

Displays the kilometres driven for the day.

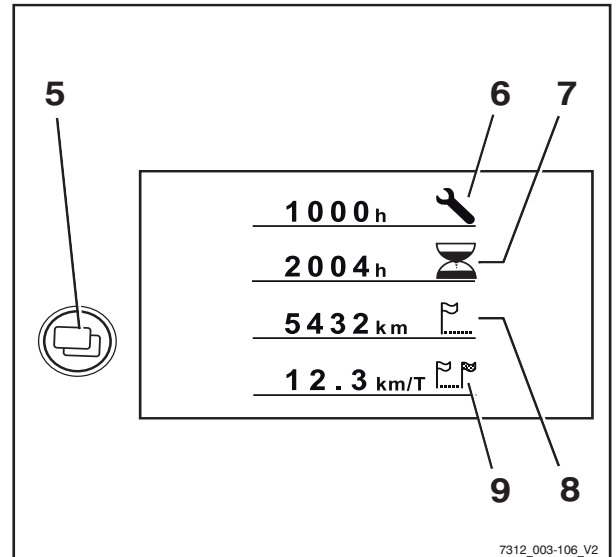

NOTE

Ask the authorised service centre about the speed driven indicator.

NOTE

Have all repair and maintenance work performed by an authorised service centre. This is the only way to permanently correct defects.

- Inform the authorised service centre when the maintenance interval is reached.

Adjusting the displays

NOTE

The parking brake must always be engaged when you adjust the displays. The displays cannot be adjusted if the parking brake is not engaged.

4 Operation

Operating the display and operating unit

i NOTE

When adjusting the displays, do not actuate the hydraulic system operating devices. If you do, entry is interrupted and the display returns to the operating display.

The displays are adjusted in the CONFIGURATION menu.

- Turn the key switch to position "I".
- Press the drive program button (1) and the menu change button (2) at the same time. ▷

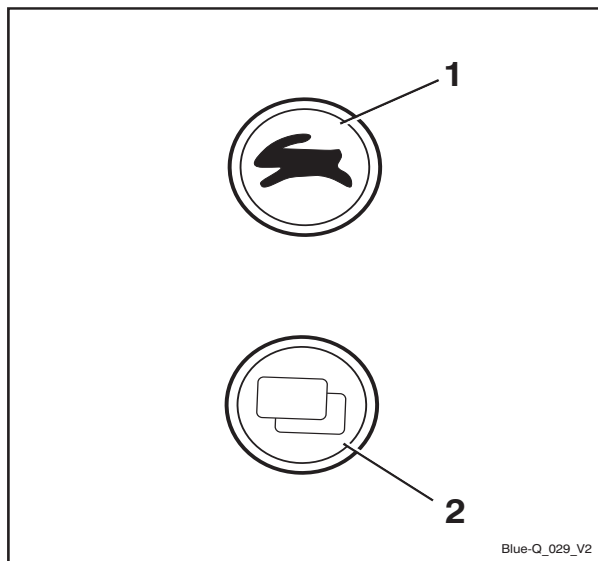

The display changes to the PASSWORD menu. ▷

i NOTE

It may be necessary to enter a password in order to configure the displays. This depends on the configuration of the display-operating unit.

- For configuration of the display-operating unit, contact the authorised service centre

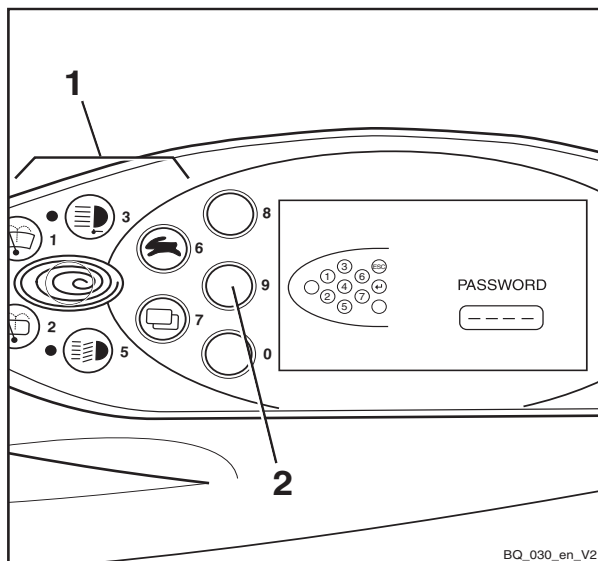

Operation

4

Operating the display and operating unit

- Press the Softkey (3).

The display changes to the CONFIGURATION menu.

The following settings are possible and can be found in the corresponding chapter:

- Setting the date and time
- Resetting the daily kilometres and daily operating hours
- Setting the language
- Configure Blue-Q

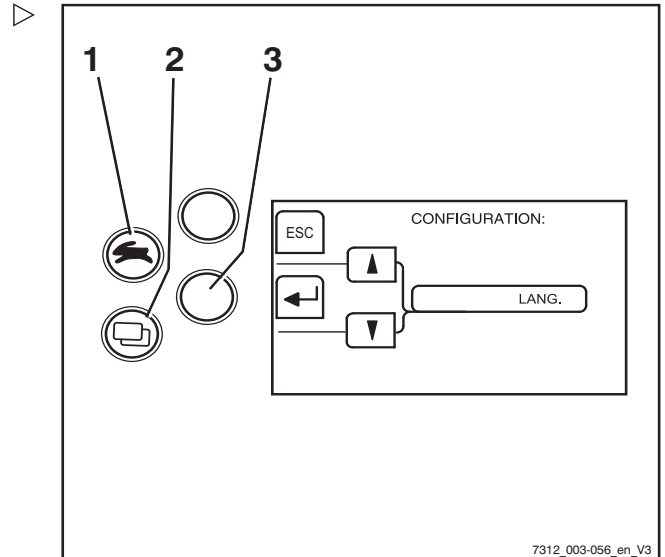

7312_003-056_en_V3

Symbols in the display

Messages

To show operating messages, warning messages or error messages in the display, text messages and symbols are used.

Symbols for operating messages

Description	Symbol
Empty field	No display
Please wait	
Service required	
Lift limitation	
Reference cycle	
Battery charging	
Drive program	
Hour meter	
Odometer	
Daily hour meter	
Daily odometer	
Speed	
Steering angle	

4 Operation

Operating the display and operating unit

Description	Symbol
Load	
Time	
Hydraulic system	
Exh.gas purifier	
Coolant temperature	
Fuel level	
Blue-Q	
Power rating (average)	
Power rating (trend)	

Symbols for warning messages

Description	Symbol
Parking brake	
Actuate seat switch	
Safety belt	
Battery acid level	
Neutral warning message	
Are you sure?	
Oil pressure	

Symbols for error messages

Description	Symbol
Brake system malfunction	
Overheating of the engine	
Overheating	
Malfunction in the electrical system	
General malfunction	

Symbols for softkey functions of auxiliary equipment

The following symbols for softkey functions are used on the left of the display for auxiliary equipment:

Description	Symbol
Empty field	No display
General function OFF	
General function ON	
Rear working spotlight OFF	
Rear working spotlight ON	
Front working spotlight OFF	
Front working spotlight ON	
Windscreen heating OFF	
Windscreen heating ON	
Rear window heating OFF	
Rear window heating ON	
Interior lighting OFF	
Interior lighting ON	
Roof wiper/washer OFF	
Roof wiper/washer ON	
Heater blower OFF	
Heater blower ON	
Rotating beacon OFF	
Rotating beacon ON	
Seat heater OFF	
Seat heater ON	
Signal horn OFF	
Signal horn ON	
Cruise control OFF	
Cruise control ON	
Automatic mast vertical positioning OFF	
Automatic mast vertical positioning ON	

Operating the display and operating unit

Description	Symbol
Load measurement zero adjustment OFF	
Load measurement zero adjustment ON	
Load measurement OFF	
Load measurement ON	

Symbols for softkey functions for menu navigation and for acknowledging messages

The following symbols for the softkey functions are used on the left of the display for menu navigation and to acknowledge messages:

Description	Symbol
Empty field	No display
Cancel input	
Confirm input	
Confirm information	
Reset	
Back by one menu level	
Back to the previous edit field	
Scroll up	
Scroll down	
Count up	
Count down	

Status LEDs of the function keys for additional electrical installations

The current switch status of a button is indicated with LEDs next to the relevant function key for the additional electrical installation.

Description	LED
Function off	LED OFF
Function on	LED ON

Symbols for numeric keypad

The buttons and Softkeys that can be used to enter numbers and to cancel or confirm input values are shown in the display.

Screen for entering the fleet manager password: ▷

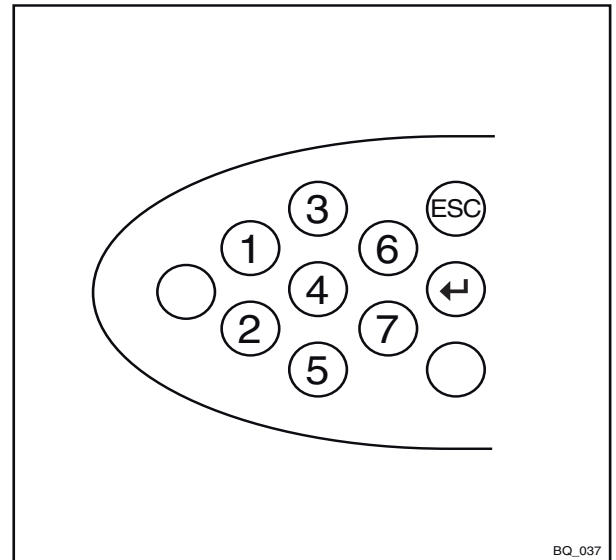

BQ_037

Screen for entering the driver PIN (access code): ▷

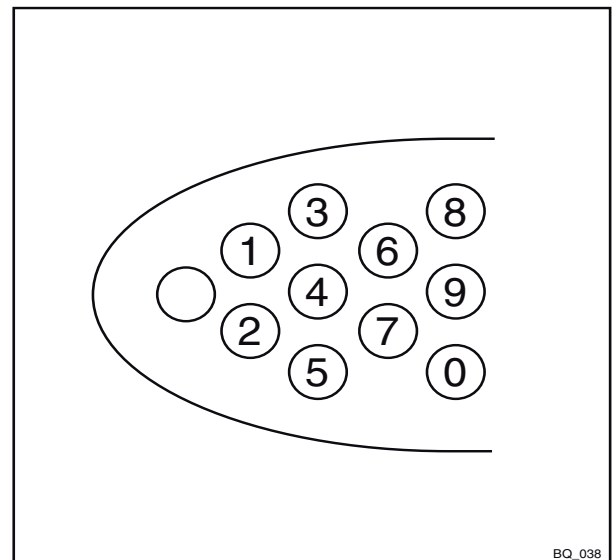

BQ_038

4 Operation

Operating the display and operating unit

Setting the date or time

- Switch to the CONFIGURATION menu; see the chapter entitled "Adjusting the displays".
- Press the Drive programme button (1) or the Menu change button (2) repeatedly until the TIME option appears.
- Confirm your selection using the Softkey (↵) (4).

The TIME menu appears.

- Press and hold down the Drive programme button (1) or Menu change button (2) until the desired time appears on the display.

As the buttons are held down for longer, the scrolling speed increases in three levels.

- Confirm the set time using Softkey (↵) (4).
- Use the Softkey (←) (3) to exit the menu and return to the next level up.

i NOTE

The date is set in a similar manner.

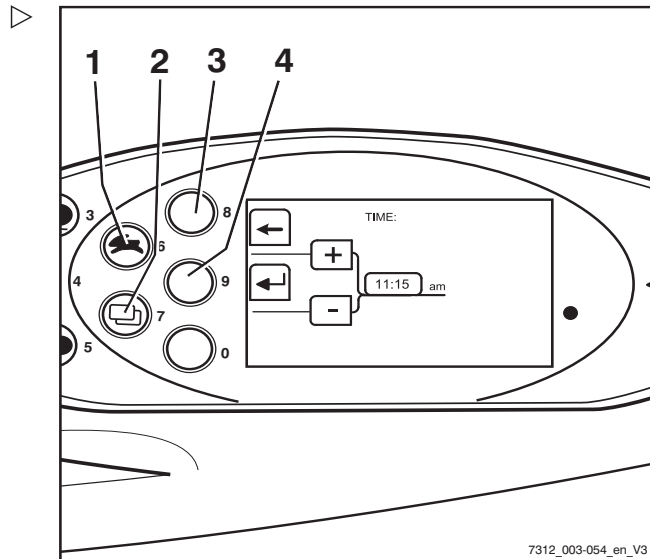

7312_003-054_en_V3

Resetting the daily kilometres and daily operating hours

The daily number of kilometres and daily operating hours displays can be reset to zero:

- Switch to the CONFIGURATION menu; see the chapter entitled "Adjusting the displays".
- Press the Drive programme button (1) or the Menu change button (2) repeatedly until the DAY KM option appears.
- Confirm your selection using the Softkey (↵) (4).

The DAY KM menu appears.

- Reset the displayed mileage using Softkey (RES) (4).
- Use the Softkey (←) (3) to exit the menu and return to the next level up.

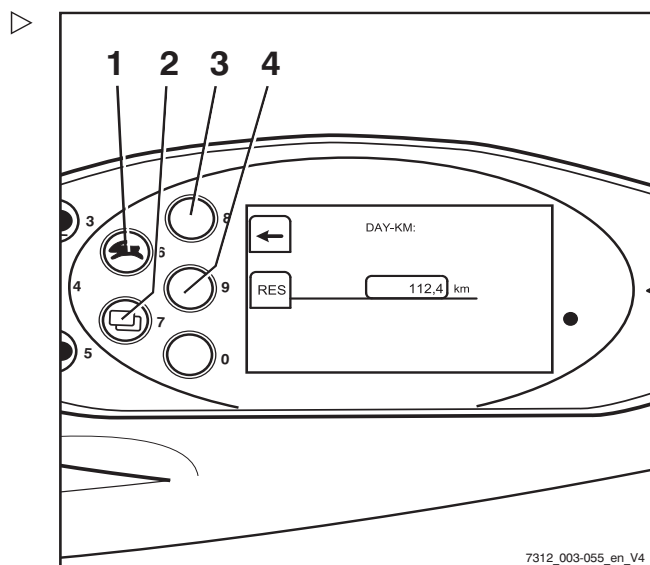

7312_003-055_en_V4

i NOTE



The daily operating hours are reset in the same manner.

Setting the language

The displays can be shown in additional languages:

- Switch to the CONFIGURATION menu; see the chapter entitled "Adjusting the displays".
- Press the drive programme button (1) or the menu change button (2) repeatedly until the LANGUAGE option appears.
- Confirm your selection using the Soft-key  (4).

The LANGUAGE menu appears.

- Press drive program button (1) or menu change button (2) until the desired language appears in the display.
- Confirm your selection using the Soft-key  (4).
- Use the Softkey  (3) to exit the menu and return to the next level up.

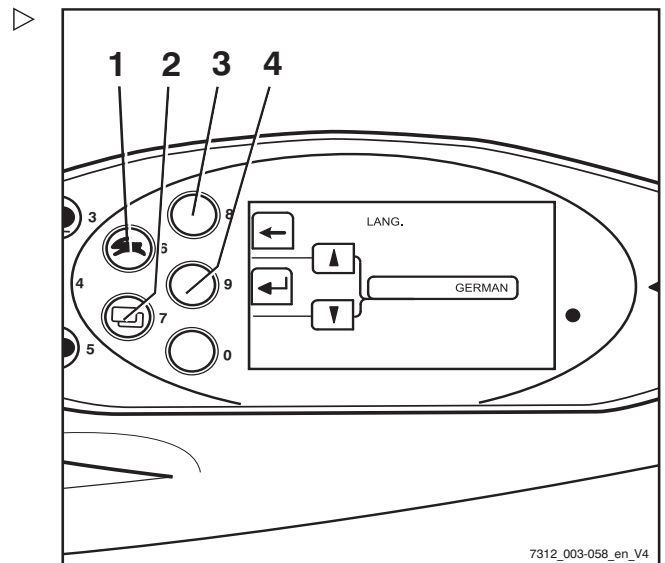

Softkeys for operating various equipment variants

Additional functions can be displayed on the display-operating unit. These additional functions, e.g. a rotating beacon, can be switched on and off using Softkeys.

4 Operation

Operating the display and operating unit

Changing the Softkey functions:

A grey bar (3) highlights the Softkey column. This is the right-hand column in the example shown here. These additional functions can now be switched on and off via the corresponding Softkeys (2). The right-hand column is only populated with additional functions if the truck has more than three equipment variants that can be switched on and off using Softkeys.

In this case, proceed as follows to switch between the two columns:

- Briefly press the Menu change button (1).

The grey bar jumps to the left-hand column. These additional functions can now be switched on and off via the corresponding Softkeys (2).

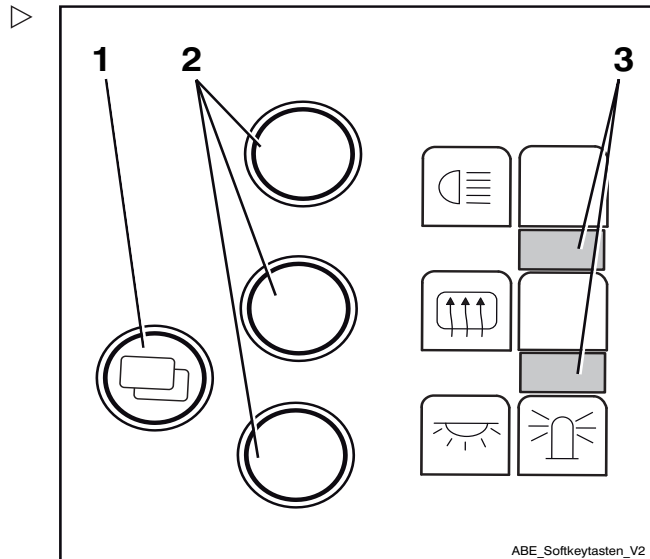

i NOTE

Press the Menu change button (1) for approx. 1 second to switch between the individual menus on the display-operating unit.

i NOTE

The additional functions depend on the individual equipment of the truck and may vary from those shown here.

Configuring Blue-Q efficiency mode

The following operating modes can be selected to activate the Blue-Q efficiency mode:

STANDARD

- Blue-Q is turned off whenever the truck is commissioned. The driver can use the Blue-Q button to switch efficiency mode on and off at any time while the truck is being operated



FIXED

- Blue-Q is switched on permanently whenever the truck is commissioned and during truck operation. The driver cannot turn efficiency mode off

FIXED - FLEX

- Blue-Q is turned on whenever the truck is commissioned. The driver can use the Blue-Q button to switch efficiency mode on and off at any time while the truck is being operated
- Switch to the CONFIGURATION menu; see the chapter entitled "Adjusting the displays".
- Keep pressing the drive programme button (1) or the menu change button (2) until option BLUE Q CONFIGURATION appears.
- Confirm your selection with Softkey  (4).

The BLUE-Q CONFIGURATION menu appears.

- Press drive program button (1) or menu change button (2) until the desired efficiency mode appears in the display.
- Confirm the set efficiency mode using Softkey  (4).
- Use the Softkey  (3) to exit the menu and return to the next level up.

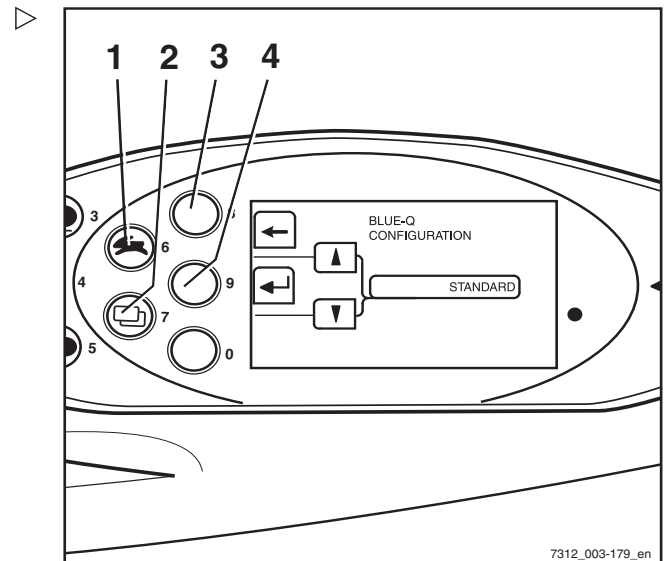

Blue-Q efficiency mode

Blue-Q efficiency mode

Functional description

The Blue-Q efficiency mode affects both the drive unit and the activation of the additional consumers, and reduces the truck's energy consumption.

If the efficiency mode has been activated, the acceleration behaviour of the truck changes to make acceleration more moderate.

When travelling at low speeds—normally when manoeuvring—no reduction is noticeable despite the activated efficiency mode. For moderate speeds of at least approx. 7 km/h, acceleration is gentler. Therefore, on distances of up to approx. 40 m, lower speeds are reached than would be the case if the efficiency mode was not activated.

Blue-Q has no influence on:

- Maximum speed
- Climbing capability
- Traction
- Braking characteristics

NOTE

The Blue-Q efficiency mode can be switched on and off in the STANDARD and FIXED-FLEX operating modes. If the FIXED operating mode is configured in the display operating unit, the Blue-Q button has no function and the Blue-Q efficiency mode is switched on permanently; see also chapter "Configuring Blue-Q efficiency mode".

Switching off additional consumers

If the Blue-Q efficiency mode is activated, the controller switches off various additional consumers after a few seconds in certain conditions. The additional consumers available depend on the truck equipment. The following table shows the conditions that cause additional consumers to be switched off. Only one of the conditions listed must be met.

Additional consumers	Condition		
	Seat switch not actuated	Truck stopped	Truck is in motion
Front working spotlights	X	X	Backwards > 3 km/h
Rear working spotlights	X	X	Forwards
Top double working spotlight	X	X	> 3 km/h
Headlights	X	X	-
Front wiper	X	X	Backwards > 3 km/h
Rear wiper	X	X	Forwards
Seat heater	X	-	-
Cab heating	X	-	-

NOTE

On the version with StVZO (German Road Traffic Licensing Regulations) equipment, the Blue-Q efficiency mode does not switch off the lighting devices headlights and working spotlights, side lights, rear lights and license plate lamps.

Switching efficiency mode Blue-Q on and off

NOTE

The Blue-Q efficiency mode can be switched on and off in the STANDARD and FIXED-FLEX operating modes. If the FIXED operating mode is configured in the display-operating unit, the Blue-Q button is disabled and the Blue-Q efficiency mode is switched on permanently. For information on

4 Operation

Blue-Q efficiency mode

configuring the Blue-Q operating modes, see the "Configuring Blue-Q efficiency mode" section.

- Press the Blue-Q button (2) to switch on Blue-Q.

The Blue-Q symbol (1) is displayed. The LED (3) illuminates in blue. Blue-Q efficiency mode is switched on.

- To switch it off, press the Blue-Q button (2) again.

The Blue-Q symbol (1) and the LEDs (3) go out. Blue-Q efficiency mode is switched off.

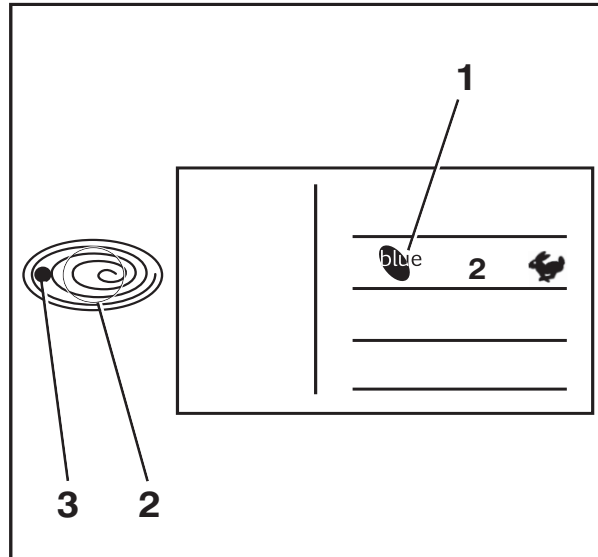

Traction

Safety regulations when driving

Driving conduct

The driver must follow the public rules of the road when driving in company traffic.

The speed must be appropriate to the local conditions.

For example, the driver must drive slowly around corners, in tight passageways, when driving through swing-doors, at blind spots, or on uneven surfaces.

The driver must always maintain a safe braking distance from vehicles and persons in front, and must always have the truck under control. Stopping suddenly, turning quickly and overtaking at dangerous or blind spots must be avoided.

- Initial driving practice must be carried out in an empty space or on a clear roadway.

The following are forbidden during driving:

- Allowing arms and legs to hang outside the truck
- Leaning the body over the outer contour of the truck
- Climbing out of the truck
- Moving the driver's seat
- Adjusting the steering column
- Releasing the seat belt
- Disabling the restraint system
- Raising the load higher than 300 mm above the ground (with the exception of manoeuvring processes during the placement into stock/removal from stock of loads)
- Using electronic devices, for example radios, mobile phones etc.



Traction

⚠ WARNING

The use of multimedia and communication equipment as well as playing these devices at an excessive volume during travel or when handling loads can affect the operator's attention. There is a risk of accident!

- Do not use devices during travel or when handling loads.
- Set the volume so that warning signals can still be heard.

⚠ WARNING

In areas where use of mobile phones is prohibited, use of a mobile phone or radio telephone is not permitted.

- Switch off the devices.

Visibility when driving

The driver must look in the drive direction and have a sufficient view of the driving lane.

Particularly for reverse travel, the driver must be sure that the driving lane is clear.

When transporting goods that impair visibility, the driver must drive the truck in reverse.

If this is not possible, a second person acting as a guide must walk in front of the truck.

In this case the driver must only move at walking pace and with extra care. The truck must be stopped immediately if eye contact with the guide is lost.

Rear-view mirrors are only to be used for observing the road area behind the truck and not for reverse travel. If visual aids (mirror, monitor) are necessary to achieve sufficient visibility, it is necessary to practise using them. For reverse travel using visual aids, extra care should be taken.

When using attachments, special conditions apply; see the chapter entitled "Fitting attachments".

Any glass (variant, e.g. windscreen) and mirrors must always be clean and free of ice.

Roadways

Dimensions of roadways and aisle widths

The following dimensions and aisle width requirements apply under the specified conditions to ensure safe manoeuvring. In each case, it must be checked whether a larger aisle width is necessary, e.g. in the case of different load dimensions.

Within the EU, Directive 89/654/EEC (minimum safety and health requirements for the workplace) must be observed. The respective national guidelines apply for areas outside of the EU.

The required aisle widths depend on the dimensions of the load.

For pallets, these are:

Model	Type	Aisle width [mm]	
		With pallet 1000 x 1200 crosswise	With pallet 800 x 1200 lengthwise
RX60-60	6341	4907	5107
RX60-70	6342		
RX60-80	6343		
RX60-80 (LSP 900)	6344	4999	5199

The truck may only be used on roadways that do not have excessively sharp bends, excessively steep gradients or excessively narrow or low entrances.

Driving on gradients

⚠ WARNING

Driving up and down longer gradients may cause the drive unit to overheat and switch off.

Driving up and down long gradients steeper than 15% is not permitted due to the minimum specified braking values. The climbing capability values given below apply only to overcoming obstacles on the roadway and to short differences in level, e.g. ramps.

The truck may be driven on the following upwards or downwards gradients:

Traction

Model	Type	Maximum gradient [%]	
		With load	Without load
RX60-60 (LSP 600)	6341	16.3	25.0
RX60-70 (LSP 600)	6342	15.5	25.3
RX60-80 (LSP 600)	6343	14.0	23.4
RX60-80 (LSP 900)	6344	12.0	18.3

LSP = load centre of gravity

The stated values are used only to compare performance of trucks in the same category. The gradient values in no way represent the normal daily operating conditions.

⚠ CAUTION

To use the truck safely—with or without a load—the maximum ascending or descending gradient permitted for travel is 15%.

- If you have any questions, please contact the authorised service centre.

The upwards and downwards slopes must not exceed the above gradient and should have a rough surface.

Smooth and gradual transitions at the top and bottom of the gradient should prevent the load from falling to the ground or the truck being damaged.

Warning: Components may project beyond the truck contour

Trucks are often required to drive through very narrow or very low spaces such as aisles or containers. The dimensions of the trucks are designed for this purpose. However, movable parts may project beyond the truck contour and be damaged or torn off. Examples of such components include:

- A folding roof panel in the driver's cab
- Cab doors
- LPG cylinders that can be swung out

Condition of roadways

Roadways must be sufficiently firm, level and free from dirt and fallen objects.

Drainage channels, level crossings and similar obstacles must be evened out, and if necessary, ramps must be provided so that trucks can drive over these obstacles with as few bumps as possible.

Ensure manhole covers and similar covers have adequate load capacity.

There must be sufficient distance between the highest points of the truck or the load and the fixed elements of the surrounding area. The height is based on the overall height of the lift mast and the dimensions of the load; see the chapter entitled "Technical data".

Rules for roadways and the working area

It is only permitted to drive on routes authorised for traffic by the operating company or its representatives. Traffic routes must be free of obstacles. The load may only be set down and stored in the designated locations. The operating company and its representatives must ensure that unauthorised third parties do not enter the working area.

NOTE

Please note the definition of "operating company" in the sense of responsible persons!

Hazard areas

Hazard areas on roadways must be marked by standard traffic signs or, if necessary, by additional warning signs.

Setting the drive programme

The driving and braking characteristics of the drive can be set on the display and operating unit.

4 Operation

Traction

- Push the drive programme button (1) repeatedly until the number of the desired drive programme appears on the display (2).

Drive programs 1–5 are available.

Essentially, the higher the drive program number is, the greater the driving dynamics.

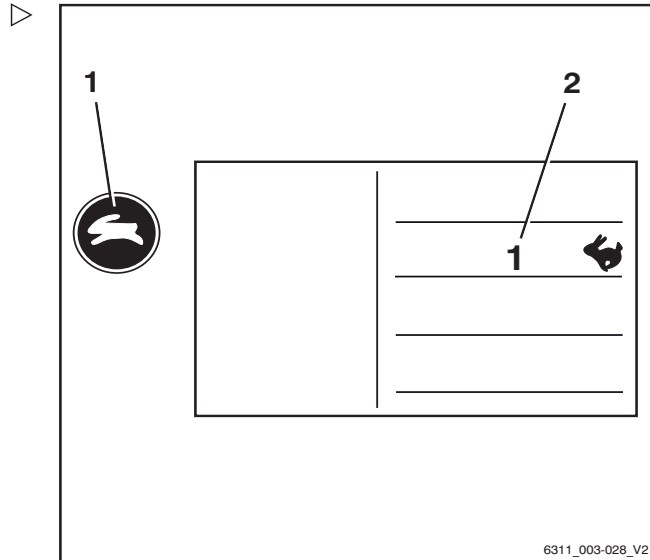

The following drive programmes are available:

Drive values ¹	Drive programme				
	1	2	3	4	5
Maximum speed (km/h)	19	19	19	19	19
Acceleration (%) (forwards/backwards)	80	90	100	110	120
Deceleration (%) (forwards/backwards)	80	90	100	110	120
Reversing (%) (forwards/backwards)	80	90	100	110	120
Brake retardation (%) (electric brake booster)	60	70	80	90	100

i NOTE

The maximum speed pre-set in the drive programme is technically dependent on the battery used. Depending on the battery type used, the preset maximum speed must be adapted by the authorised service centre. If the maximum speed is not adapted, it can lead to technical faults in drive mode.

- Contact your authorised service centre.

Battery designation	Maximum speed (km/h)
7 PzS 1085 PowerPlusLife®	20
8 PzS 1120	19

¹ Values applicable to the standard device. Values for variants may deviate from this data.

Battery designation	Maximum speed (km/h)
8 PzS 1240	19
SENSOR® TCSM 2545	17

Sprint mode (variant)

NOTE

Sprint mode is only possible in combination with the PowerPlusLife battery.

Switching on sprint mode

The performance of the electric drive can be increased by switching on sprint mode. When sprint mode is on, the truck accelerates to maximum speed more quickly.

NOTE

With sprint mode switched on, the truck's energy consumption is higher. The battery is therefore discharged more quickly.

- Push button (1).

Sprint mode is switched on, the symbol has a dark background.

NOTE

Sprint mode remains on until the seat is vacated or button (1) is pushed again.

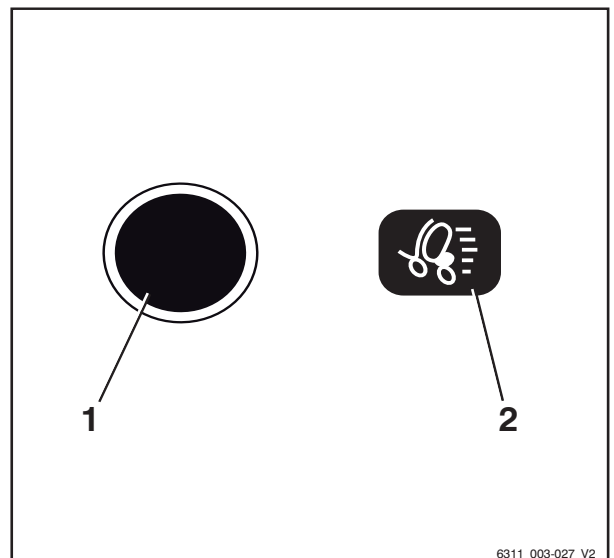

6311_003-027_V2

4

Operation

Traction

Switching off sprint mode

- Push button (1).

Sprint mode is switched off, the symbol has a light background.

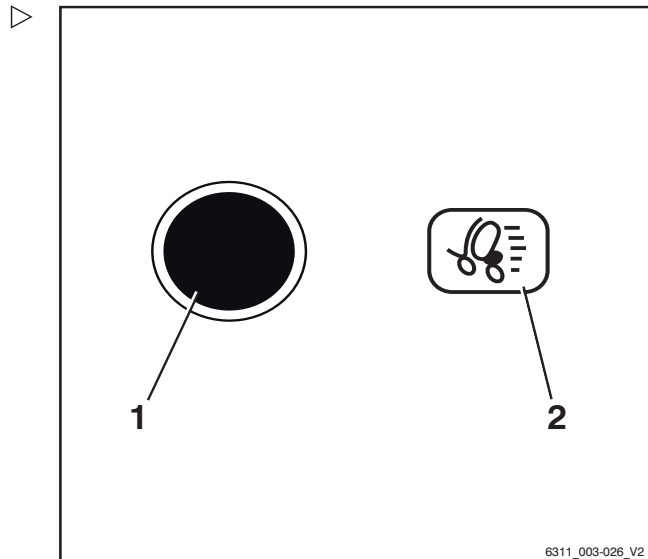

Selecting the drive direction

The desired drive direction of the truck must be selected using the drive direction switch before attempting to drive. The method of actuating the drive direction switch depends on the operating devices included in the truck's equipment.

Possible equipment variants include:

- Mini-lever
- Joystick 4Plus
- Fingertip switch
- Mini-console

i NOTE

The drive direction can also be changed during travel. Your foot can remain on the accelerator pedal while doing so. The truck is then decelerated and accelerated again in the opposite direction (reversing).

The indicator for the selected drive direction ("forwards" (1) or "reverse" (2)) lights up on the display and operating unit.

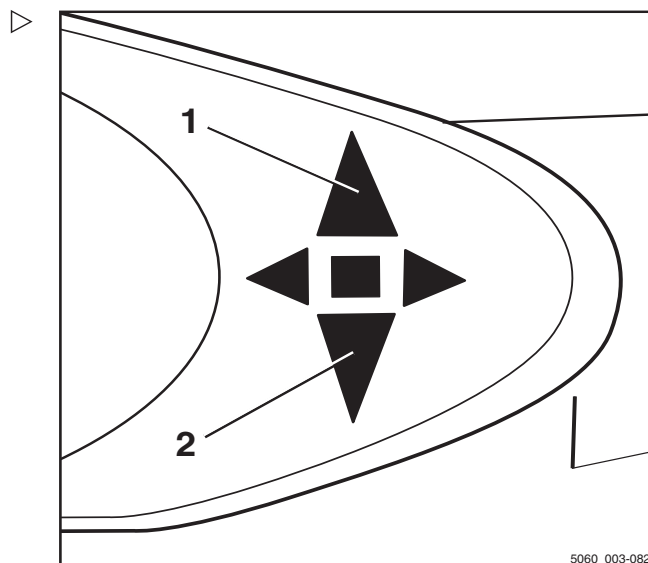

Neutral position

If the truck is stopped for an extended period, select the neutral position to prevent the truck

from suddenly starting if the accelerator pedal is inadvertently pressed.

- Briefly select the drive direction switch for the direction opposite to the current direction.

The drive direction indicator on the display and operating unit goes out.

i NOTE

When the seat is vacated, the drive direction switch is set to "Neutral". To drive, the drive direction switch must be actuated again.

Actuating the drive direction switch, mini-lever version

- Push the cross lever (1) forwards to drive "forward".
- Pull the cross lever backwards to drive "backward".

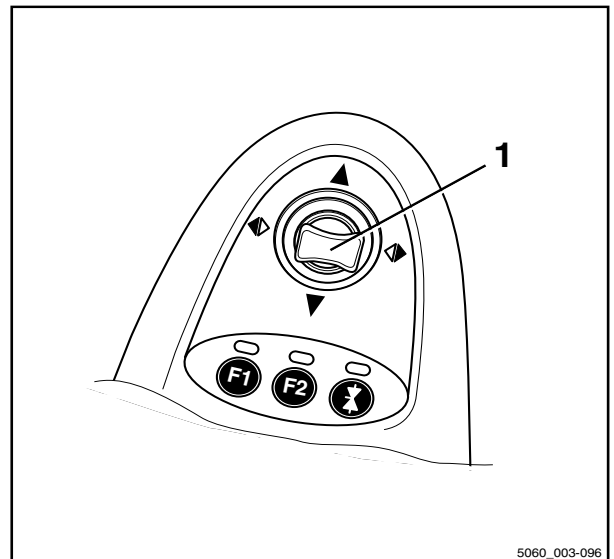

4

Operation

Traction

Actuating the vertical rocker switch for the "drive direction", joystick 4Plus version

- For the "forwards" drive direction, push the vertical rocker button for the "drive direction"(1) upwards (A).
- For the "reverse" drive direction, push the vertical rocker button for the "drive direction"(1) downwards (B).

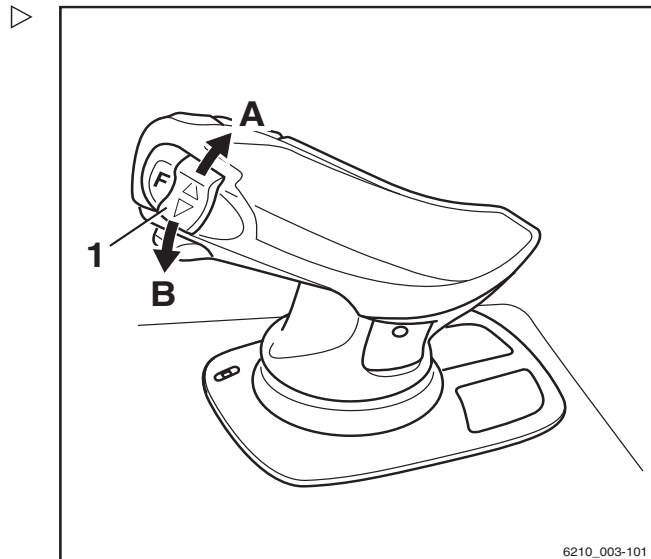

6210_003-101

Actuate the drive direction switch, fingertip version

- For the "forwards" drive direction, push the drive direction switch (1) forwards.
- For the "backwards" drive direction, push the drive direction switch backwards.

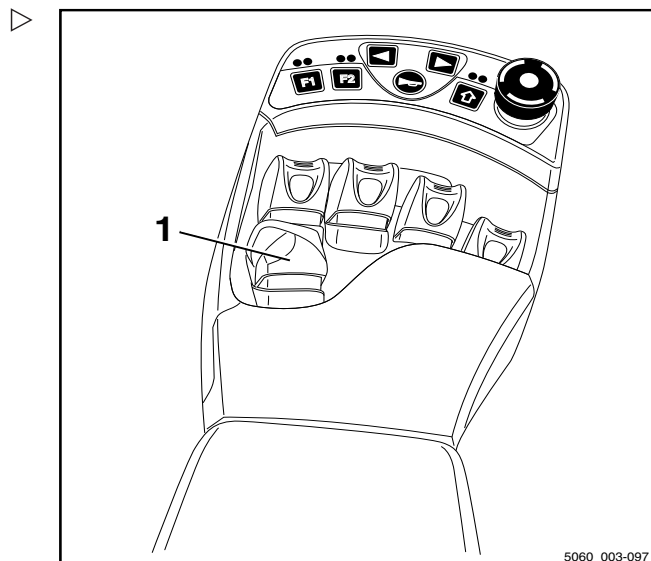

5060_003-097

Actuating the drive direction switch, mini-console version

- For the "forwards" drive direction, push the drive direction switch (1) forwards.
- For the "backwards" drive direction, push the drive direction switch to the rear.

i NOTE

Alternatively, the drive direction can also be selected using the drive direction switches on the operating devices.

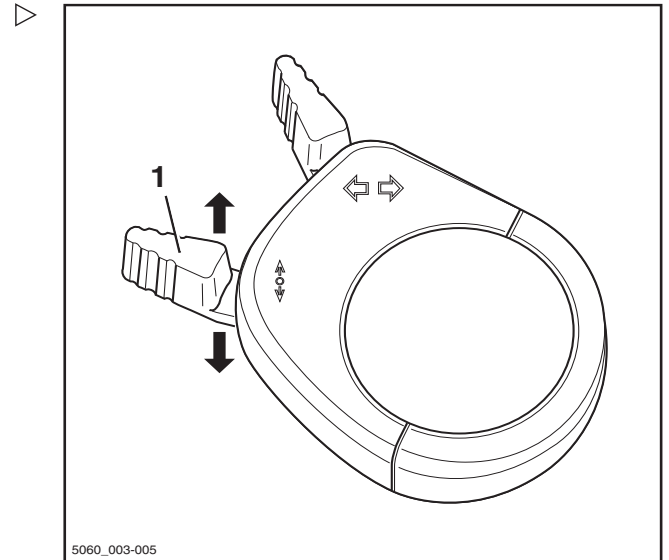

Starting drive mode

⚠ DANGER

Risk to life if the truck rolls away or tips over!

- Sit on the driver's seat.
- Fasten the seat belt.
- Activate the available restraint systems.

Observe the information in the chapter entitled "Safety regulations when driving".

The driver's seat has a seat switch that checks whether the driver's seat is occupied. The truck cannot be moved if the driver's seat is not occupied or if the seat switch malfunctions. All lifting functions are disabled. The SEAT SWITCH message appears on the display-operating unit.

- Lift the fork carriage until the necessary ground clearance is achieved.
- Tilt the lift mast backwards.
- Release the parking brake.
- Select the desired drive direction.

4

Operation

Traction

The indicator for the selected drive direction ("forwards" (1) or "reverse" (2)) lights up on the display-operating unit.

i NOTE

Depending on the equipment, an acoustic signal (variant) may sound a warning during reverse travel, the warning light (variant) may light up or the hazard warning system (variant) may flash.

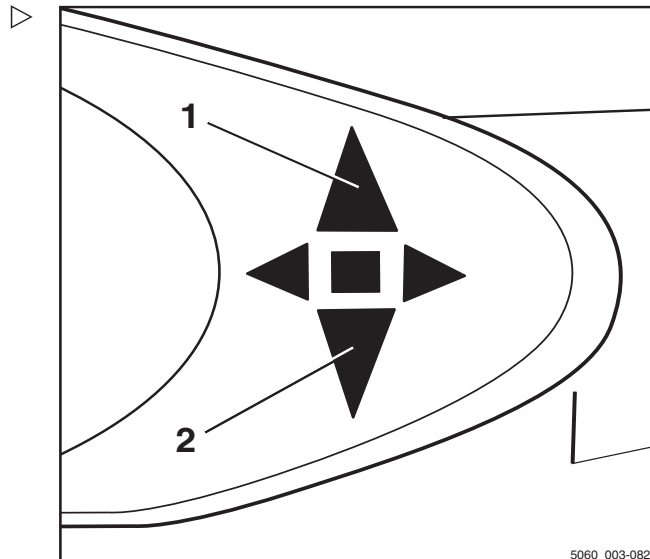

– Press the accelerator pedal (3).

The truck will travel in the selected drive direction. The accelerator pedal position controls the speed. When the accelerator pedal is released, the truck brakes automatically via the regenerative brake.

i NOTE

The regenerative brake holds the truck briefly, even on ascending or descending gradients, without the parking brake being actuated. The truck will then begin to creep downhill slowly.

i NOTE

If the following message appears in the display when the accelerator pedal is actuated:

! PARKING BRAKE OIL PRESSURE, *the service brake of the truck is not yet ready for operation.*

- *The driving speed is limited to 5 km/h.*
- *The message disappears when the service brake is ready for operation. The speed limitation is cancelled.*

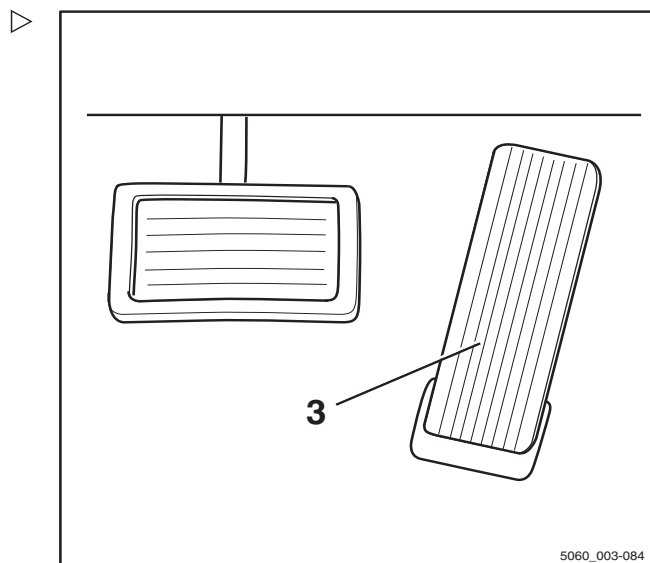

⚠ DANGER

Risk of accident due to brake failure!

The electric brake only functions while the key switch is switched on, the emergency off switch has not been actuated and the parking brake is released.

- Use the brake pedal if the electric brake malfunctions.
- Only leave the truck when the parking brake is applied.

Changing the drive direction

- Remove your foot from the accelerator pedal.
- Select the desired drive direction.
- Actuate the accelerator pedal.

The truck will travel in the selected drive direction.

i NOTE

The drive direction can also be changed during travel. Your foot can remain on the accelerator pedal while doing so. The truck is then decelerated and accelerated again in the opposite direction (reversing).

i NOTE

If an electrical fault occurs in the accelerator, the drive unit switches off. The truck is braked by the regenerative brake. Once the electrical fault has been corrected, it will be possible to drive the truck again by releasing the accelerator pedal and then actuating the accelerator pedal again. If the truck still cannot be operated, park the truck securely and contact the authorised service centre.

Traction

Starting drive mode, dual pedal version (variant)

⚠ DANGER

Risk to life if the truck rolls away or tips over!

- Sit on the driver's seat.
- Fasten the seat belt.
- Activate the available restraint systems.

Observe the information in the chapter entitled "Safety regulations when driving".

The driver's seat has a seat switch that checks whether the driver's seat is occupied. The truck cannot be moved if the driver's seat is not occupied or if the seat switch malfunctions. All lifting functions are disabled. The SEAT SWITCH message appears on the display-operating unit.

- Lift the fork carriage until the necessary ground clearance is achieved.
- Tilt the lift mast backwards.
- Release the parking brake.
- Actuate the right-hand accelerator pedal (1) to drive "forward" and actuate the left-hand accelerator pedal (2) to drive "backward".

i NOTE

In the dual pedal version, the drive direction switches on the operating devices do not function.

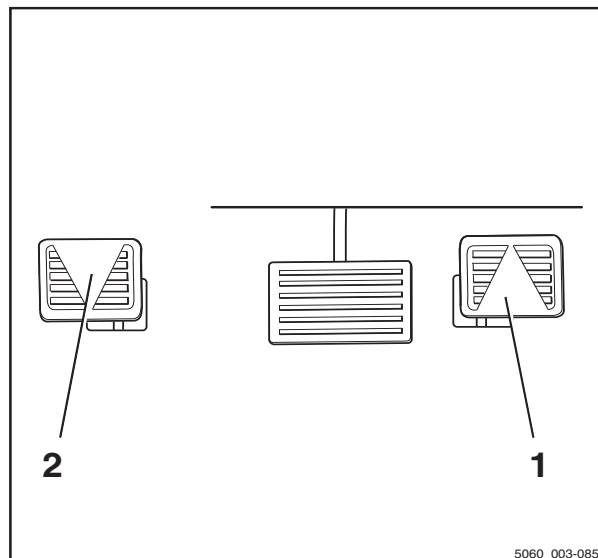

The indicator for the selected drive direction ("forwards" (3) or "reverse" (4)) lights up on the display-operating unit.

i NOTE

Depending on the equipment, an acoustic signal (variant) may sound a warning during reverse travel, the warning light (variant) may light up or the hazard warning system (variant) may flash.

The truck will travel in the selected drive direction. The accelerator pedal position controls the speed. When the accelerator pedal is released, the truck brakes automatically via the regenerative brake.

i NOTE

The regenerative brake holds the truck briefly, even on ascending or descending gradients, without the parking brake being actuated. The truck will then begin to creep downhill slowly.

i NOTE

If the following message appears in the display when the accelerator pedal is actuated:

! PARKING BRAKE OIL PRESSURE, the service brake of the truck is not yet ready for operation.

- *The driving speed is limited to 5 km/h.*
- *The message disappears when the service brake is ready for operation. The speed limitation is cancelled.*

⚠ DANGER

Risk of accident due to brake failure!

The electric brake only functions while the key switch is switched on, the emergency off switch has not been actuated and the parking brake is released.

- Use the brake pedal if the electric brake malfunctions.
- Only leave the truck when the parking brake is applied.

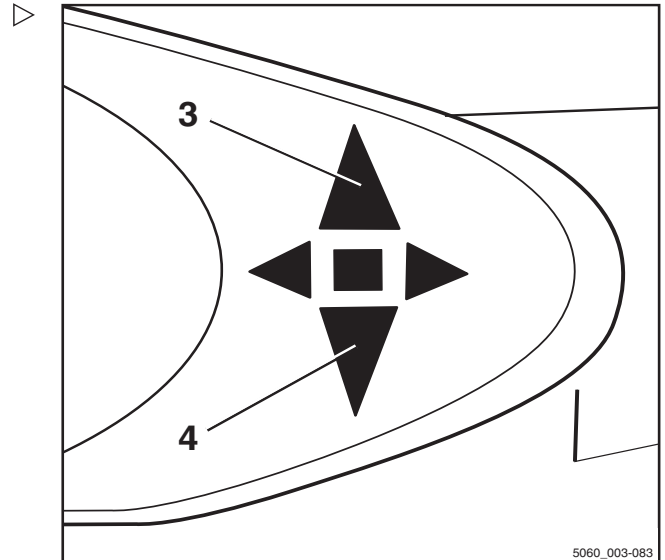

5060_003-083



4

Operation

Traction

Changing the drive direction

- Remove foot from actuated accelerator pedal.
- Actuate the accelerator pedal for the opposite direction.

The truck will travel in the selected drive direction.

 NOTE

If an electrical fault occurs in the accelerator, the drive unit switches off. The truck is braked by the regenerative brake. Once the electrical fault has been corrected, it will be possible to drive the truck again by releasing the accelerator pedal and then actuating the accelerator pedal again. If the truck still cannot be operated, park the truck securely and contact the authorised service centre.

Operating the service brake

The electric brake converts the acceleration energy of the truck into electrical energy. This causes the truck to decelerate.

Electrical braking recovers energy for the battery. This results in a longer operating time between charging operations and less wear to the brakes.

The truck can also be braked with the mechanical brake by actuating the brake pedal (2). In the first section of the brake pedal's travel, only the electric brake takes effect. As the pedal is depressed further, the mechanical brake is also activated and acts on the drive wheels

⚠ DANGER

If the service brake fails, the truck cannot brake sufficiently. There is a risk of accident!

If the driver notices that the electrical braking effect has reduced by 50% and that the drive torque has decreased to 50% of the normal level, a component failure may have occurred.

- Bring the truck to a standstill using the brakes. Use the parking brake if necessary to assist in this process.
- Notify the authorised service centre.
- Do not operate the truck again until the service brake has been repaired.

⚠ DANGER

At speeds that are too high, there is a danger that the truck could slip or overturn!

The braking distance of the truck depends on the weather conditions and the level of contamination on the roadway. Note that the basic braking distance increases with the square of the speed.

- Adapt your driving and braking style to suit the weather conditions and the level of contamination on the roadway.
 - Always choose a driving speed that will provide a sufficient stopping distance.
-
- Brake the truck by releasing the accelerator pedal (1).
 - If the braking effect is inadequate, use the brake pedal (2) as well to apply the mechanical brake.

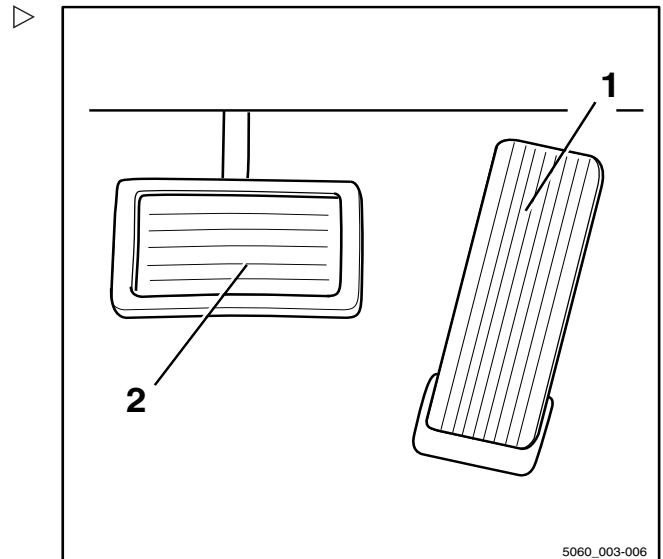

Traction

Actuating the mechanical parking brake

⚠ DANGER

There is a risk of being run over if the truck rolls away, and therefore a danger to life.

- The truck must not be parked on a slope.
- In emergencies, secure with wedges on the side facing downhill.
- Only leave the truck when the parking brake is applied.

i NOTE

Once the parking brake is released, the previously selected drive direction is retained and is shown on the drive direction indicator.

i NOTE

If you operate the accelerator pedal while the parking brake is applied and a drive direction is selected, the message PARKING BRAKE appears in the display.

Apply the parking brake

- Pull the parking brake lever (1) down fully and release.

The parking brake lever swivels back half the distance into the middle position automatically.

The parking brake is engaged and the wheels are blocked. Driving is no longer possible. The drive direction indicator (2) on the display and operating unit goes out.

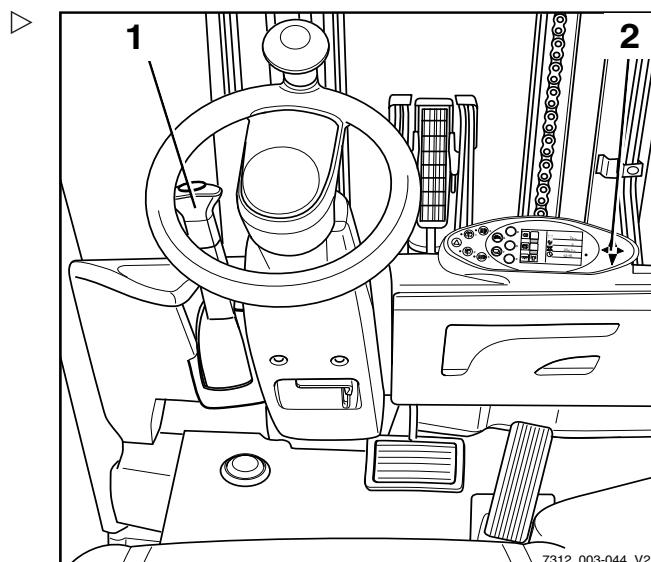

Releasing the parking brake

- Pull the parking brake lever (1) down fully out of the middle position.
- In the lower lever position, pull out the lever knob and then guide the parking brake lever up fully.

i NOTE

The parking brake lever swivels to the upper position automatically by means of spring force and should be guided only lightly by hand. If the adjustment is stiff, notify the authorised service centre.

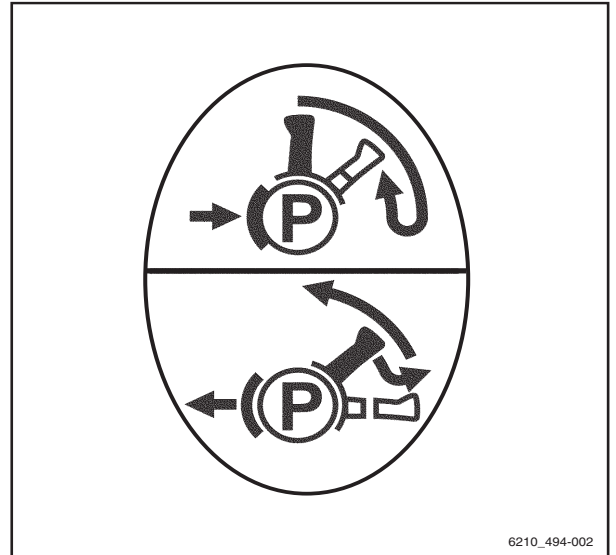

4 Operation

Traction

Steering

⚠ DANGER

If the hydraulics fail, there is a risk of accident as the steering characteristics have changed.

- Do not operate the truck if it has a defective steering system.

- Steer the truck by turning the steering wheel (1) accordingly.

Turning the steering wheel in the direction of arrow (A) steers the truck in drive direction (A).

Turning the steering wheel in the direction of arrow (B) steers the truck in drive direction (B).

For turning radius information, see ⇒ Chapter "Technical data", P. 359.

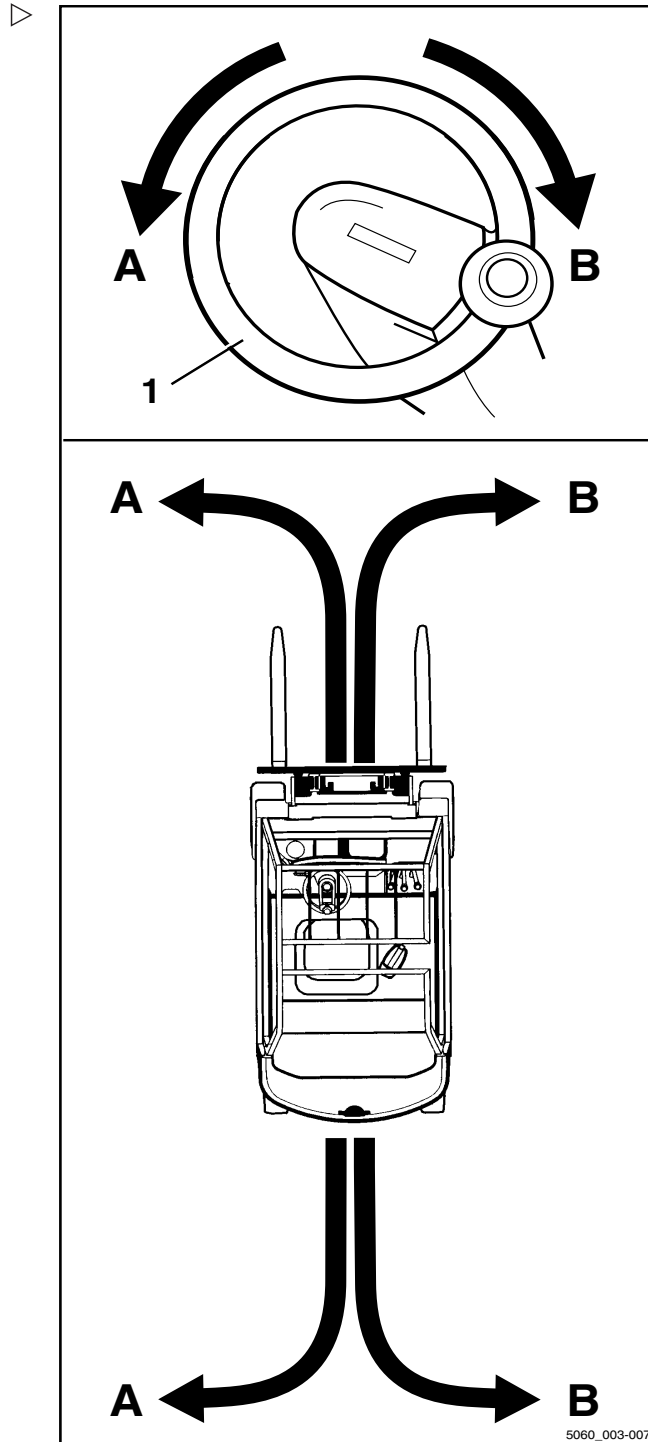

Reducing speed when turning (Curve Speed Control)

This function reduces the speed of the truck as the steering angle increases, regardless of the amount to which the accelerator has been actuated. If the steering angle is reduced again upon exiting the curve, the truck accelerates in line with how far the accelerator is depressed.

However, the function does not release the driver from the duty to approach a curve at a speed according to the following factors:

- The carried load
- The roadway conditions
- The radius of the curve

⚠ DANGER

The Curve Speed Control function cannot override the physical limits of stability. Despite this function, there still is a risk of tipping!

- Before using this function, familiarise yourself with the change to the driving and steering characteristics of the truck.

⚠ DANGER

Increased risk of tipping if the Curve Speed Control function is disabled! If the controller fails while the truck is in motion or if the controller is disabled, the truck will no longer automatically brake when steering.

- Do not turn off the key switch while driving.
- Actuate the emergency stop switch only in emergencies.
- Always adapt your driving style to the conditions.

Despite the Curve Speed Control function, the truck may overturn in extreme cases within the following situations:

- Cornering too fast on uneven or inclined roadways.
- Turning the steering wheel sharply while driving.
- Cornering with an inadequately secured load.
- Cornering too fast on a smooth or wet roadway.

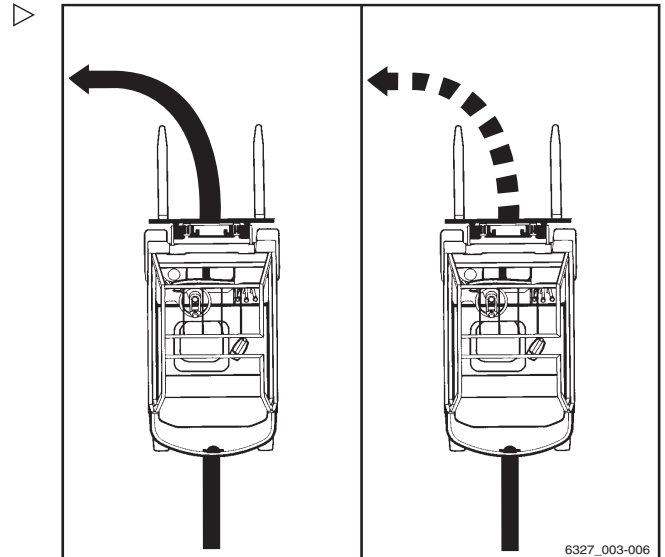

Traction

Driving on ascending and descending gradients

⚠ DANGER

Danger to life!

Driving on ascending and descending gradients carries special dangers!

- Always follow the instructions below.

- On ascending and descending gradients, the load must be carried facing uphill.
- It is only permitted to drive on ascending and descending gradients that are marked as traffic routes and that can be used safely.
- Ensure that the ground to be traversed is clean and provides a good grip.
- Do not turn on ascending and descending gradients.
- Do not drive onto or along ascending and descending gradients at an angle.
- Do not park the truck on ascending or descending gradients.
- In case of emergency, secure the truck with wedges so that the truck does not roll away.
- Reduce the driving speed on descending gradients.

It is not permitted to drive on long ascending and descending gradients greater than 15% due to the specified minimum braking and stability values.

- Before driving on ascending and descending gradients greater than 15%, consult the authorised service centre.

The process of placing loads into stock and removing loads from stock while on an ascending or descending gradient is not permitted!

- Always place loads into stock and remove loads from stock on a horizontal plane.

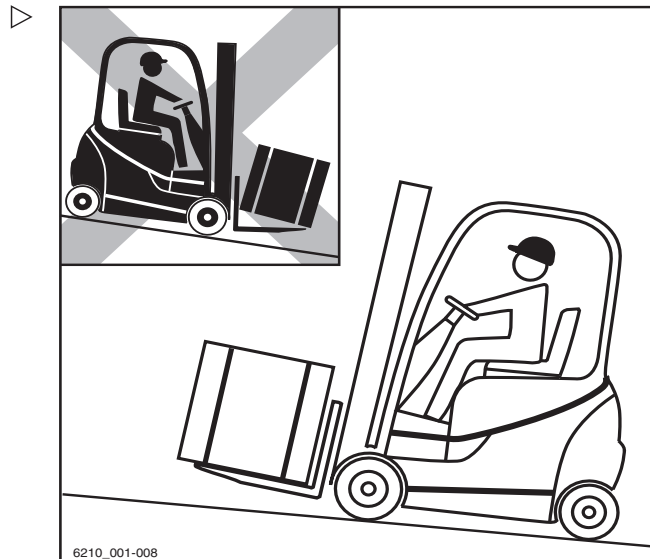

Reducing speed with a raised load (variant) ▷

This function (variant) reduces the speed of the truck with a raised load.

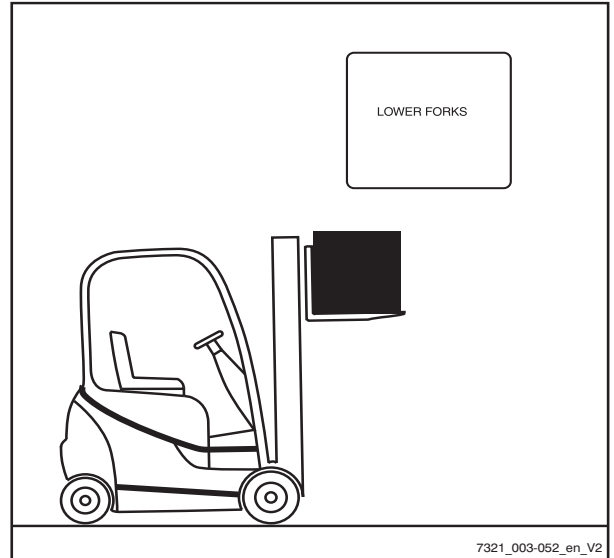

Parking

Parking

Parking the truck securely and switching it off



⚠ DANGER

Risk of fatal injury from being run over if the truck rolls away!

- The truck must not be parked on a slope.
- In emergencies, secure with wedges on the side facing downhill.
- Only leave the truck when the parking brake has been applied.



5060_003-130

⚠ DANGER

There is a risk of fatal injury from a falling load or parts of the truck being lowered!

- Lower the load fully before leaving the truck.

⚠ CAUTION

Batteries may freeze!

If the truck is parked in an ambient temperature of below -10°C for an extended period, the batteries will cool down. The electrolyte may freeze and damage the batteries. The truck will then not be ready for operation.

- At ambient temperatures of below -10°C, only park the truck for short periods of time.
- Apply the parking brake.
- Lower the fork carriage to the ground.
- Tilt the lift mast forwards until the tips of the fork arms rest on the ground.
- If attachments (variant) are fitted, retract the working cylinders; see the chapter entitled "General instructions for controlling attachments".
- Turn the switch key to the left and remove it.

i NOTE

Switch keys, FleetManager cards (variant), FleetManager transponder chips (variant) and the PIN code for access authorisation (variant) must not be handed over to other persons

unless explicit instructions to this effect have been given.

Wheel chock (variant)

The wheel chock (variant) is used to prevent the truck from rolling away on a slope.

- Lift handle (2) on the support mounting.
- Remove wheel chock (1) from the support mounting.
- Push the wheel chock under a front axle wheel on the side facing the downhill slope.

i NOTE

After use, return the wheel chock to the support mounting and press the handle (2) down again.

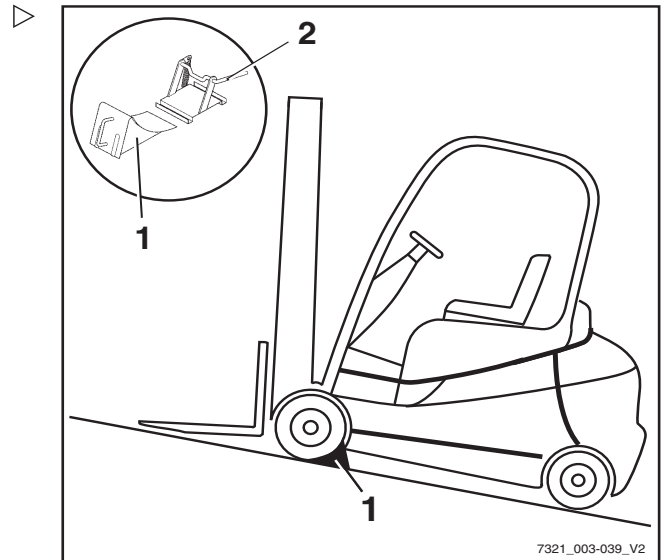

7321_003-039_V2

Lifting

Lifting

Lifting system variants

The movement of the fork carriage and the lift mast heavily depends on the following equipment:

- The lift mast with which the truck is equipped, see ⇒ Chapter "Types of lift mast", P. 4-151
- The operating device with which the hydraulic functions are controlled, see ⇒ Chapter "Lifting system operating devices", P. 4-154

Regardless of the equipment variants of the truck, the basic specifications and procedures must be complied with, see ⇒ Chapter "Safety regulations when handling loads", P. 4-167.

Automatic lift cut out (variant)

Description:

The automatic lift cut out (variant) means that the load cannot be lifted above a preset height. This function uses a sensor that is welded on at the factory at the required lift mast limit height. Once attached, the height cannot be easily changed.

Application:

- If the ceiling of the building is lower than the maximum lift height of the truck, this variant can prevent the lift mast from accidentally hitting the ceiling, which can result in damage.
- If the truck is frequently used at a particular height, the work is simplified by the automatic lift cut out at this height.

NOTE

If a load is lifted very quickly, the fork carriage and load are moved approximately 15 cm above the position of the sensor due to inertia. This deviation is already taken into consideration at the factory when determining the position of the sensor.

Overriding and reactivating the automatic lift cut out

If a load needs to be lifted to the truck's maximum lift height and the automatic lift cut out function is not required, it is possible to override the lift cut out. It is automatically reactivated when the truck is switched off and back on again.

To override the automatic lift cut out:

- Press Softkey **F1** (1).

Automatic lift cut out is switched off. The **F1** symbol is displayed. Loads can be lifted to the maximum lift height for the truck.

To switch the automatic lift cut out back on:

- Press Softkey **F1** (1).

Automatic lift cut out is switched on. The **F1** symbol is displayed. Loads can be lifted only to the set lift height for the truck.

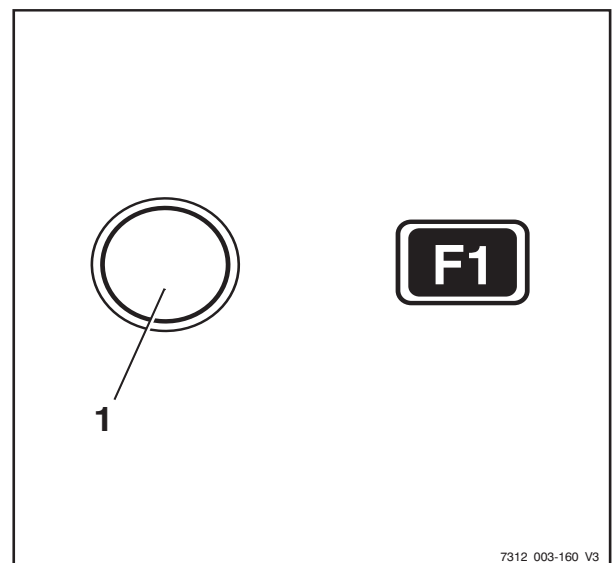

7312_003-160_V3

Lift mast vertical position (variant)

Description

If the truck is equipped with the "lift mast vertical position" comfort feature (variant), the driver can put goods, such as paper rolls, down vertically with precision and thus avoid damage when unloading. The tilt cylinders run into the end stops gently to prevent hard vibrations and impacts. Oscillating motions of the truck are minimised, thus increasing work safety. The lift mast vertical position reduces wear on various components and therefore reduces maintenance costs.

4 Operation
Lifting

⚠ CAUTION

Risk of damage to property due to the lift mast colliding with racks or other objects!

- Before using the "lift mast vertical position" comfort feature, position the truck at a sufficient distance from racks and other objects.

The "lift mast vertical position" comfort feature consists of the following individual functions:

- Display of the "lift mast vertical position"
- Automatic approach towards the "lift mast vertical position"
- Gentle running-in to the end stops

Display of the "lift mast vertical position" ▷

The driver can see the mast tilt on the display and operating unit screen. The bar in the display shows the current mast tilt relative to the "lift mast vertical position". The arrow above the bar marks the vertical position of the lift mast.

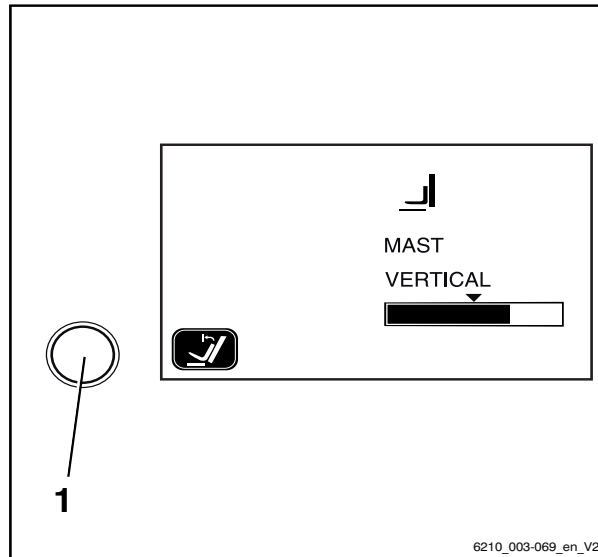

Automatic approach towards the "lift mast vertical position"

- Switch on the "lift mast vertical position" comfort feature via the button (1) on the display and operating unit.
- Tilt the lift mast forwards using the corresponding operating device. The lift mast stops automatically as soon as the preselected setting is reached for the "lift mast vertical position".

If the comfort feature is switched off, the lift mast tilts forwards past the "lift mast vertical position" without stopping.

If the lift mast is tilted backwards, it moves past the "lift mast vertical position" without stopping, regardless of whether the comfort feature is switched on or not.

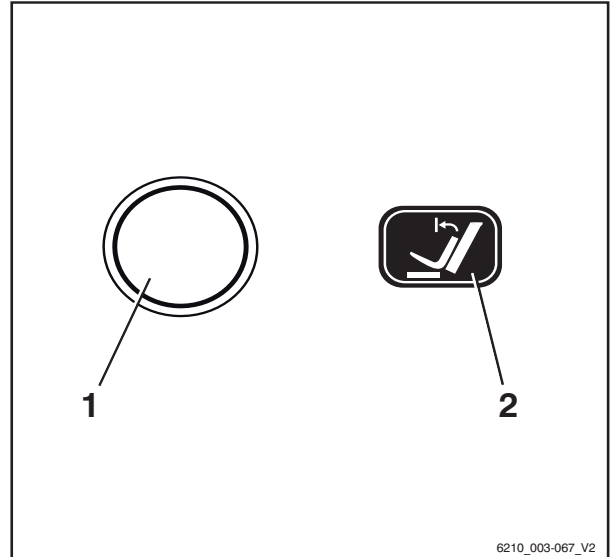

Gentle running-in to the end stops

The lift mast is braked gently at the end of the tilt range. This prevents the lift mast from stopping harshly in the end position and reduces severe oscillating motions of the truck.

Tilting the lift mast forwards with the "lift mast vertical position"

- Actuate the button (1) to switch on the "lift mast vertical position" comfort feature; the function display (2) in the display shows the activated status.
- Tilt the lift mast forwards.



NOTE

The way in which the lifting system is operated depends on the operating devices included in the truck's equipment; see the chapter entitled "Lifting system operating devices".

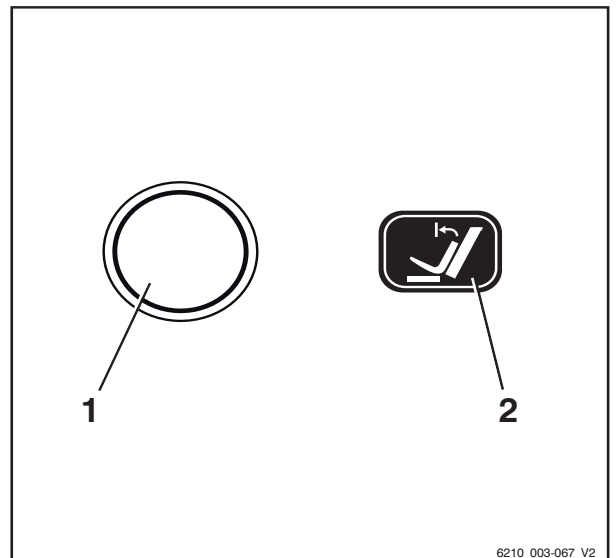

4

Operation

Lifting

The lift mast is tilted forwards and stops as soon as the vertical position is reached. The arrow above the bar shown on the screen of the display and operating unit represents the "lift mast vertical position".

Tilt the lift mast forwards beyond the vertical position:

- Release the operating device for tilting and actuate again.

The lift mast is tilted beyond the vertical position up to the end stop. The current mast tilt is shown in the display and operating unit.

- To deactivate the "lift mast vertical position", actuate the button (1) again.

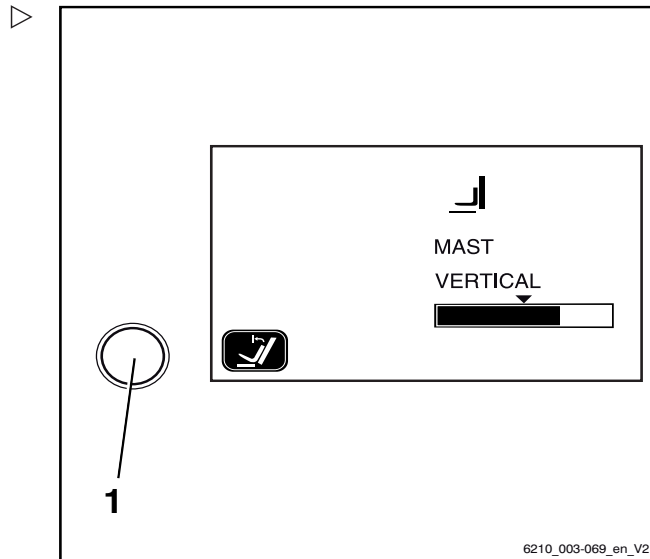

Tilting the lift mast backwards with the "lift mast vertical position"

- Tilt the lift mast backwards.

The lift mast is tilted backwards without stopping in the vertical position.

Possible restrictions on the "lift mast vertical position"

In some circumstances, the lift mast cannot move exactly into the preset vertical position. Possible causes include:

- Uneven ground
- Bent fork
- Bent attachment
- Worn tyres
- Severely deformed lift mast

The vertical position can be corrected by tilting the lift mast using the relevant operating device. If the vertical position has to be corrected frequently, the "lift mast vertical position" should be calibrated.

Calibrating the "lift mast vertical position" ▷

- Set the lift mast to the required position.
- Press and hold the button (1) for the "lift mast vertical position" for at least five seconds.

The message "? VERTICAL POSITION" will appear on the display.

Storing the mast position:

- Press the drive program button (3).

The current mast position is stored.

Cancelling calibration:

- Press the menu change button (2).

The calibration is cancelled.

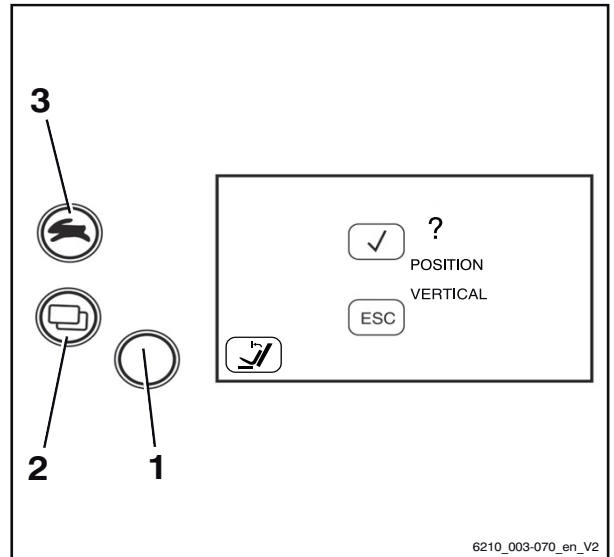

6210_003-070_en_V2

Types of lift mast

One of the following lift masts may be installed in the truck:

Telescopic mast ▷

During lifting, the lift mast rises over the outer lift cylinders, bringing the fork carriage with it via the chains (fork carriage rises twice as fast as the inner lift mast). The top edge (1) of the inner lift mast can therefore be higher than the fork carriage.

⚠ DANGER

Risk of accident due to collision of the lift mast or load with low ceilings or entrances.

- Note that the inner lift mast or load may be higher than the fork carriage.
- Note the heights of ceilings and entrances.

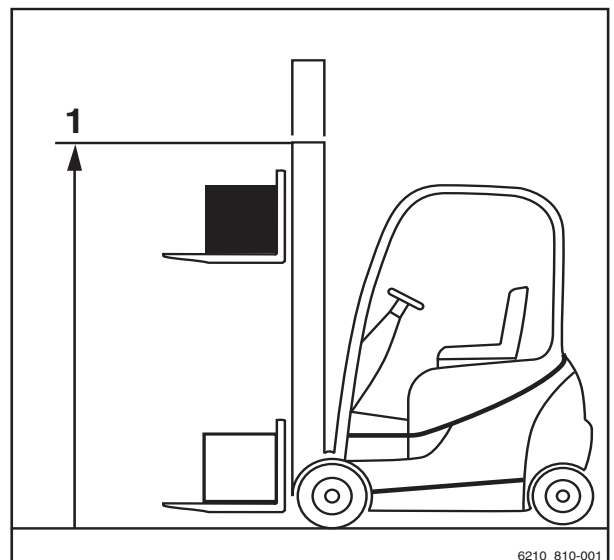

6210_810-001

4

Operation

Lifting

Triplex lift mast (variant)

During lifting, the inner lift cylinder moves up to free lift (3), and then the outer lift cylinders raise the inner lift mast up to the max. height (2).

⚠ DANGER

Risk of accident due to collision of the lift mast or load with low ceilings or entrances.

- Note that the inner lift mast or load may be higher than the fork carriage.
- Note the heights of ceilings and entrances.

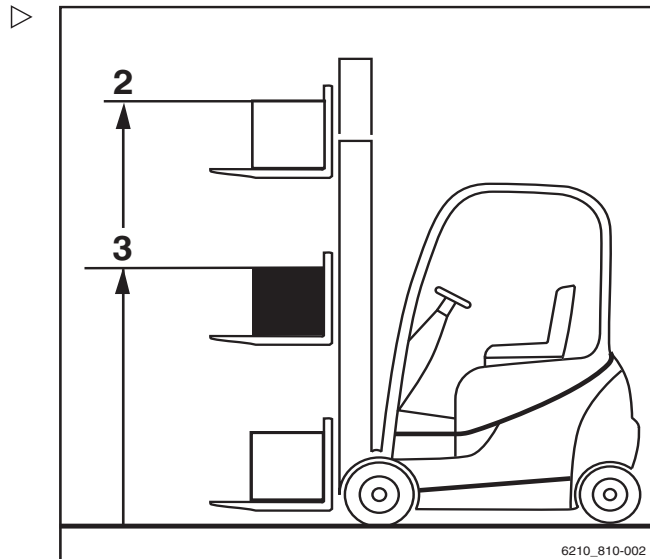

Malfunctions during lifting mode

Incorrect extension sequence

⚠ DANGER

Risk of accidents!

With triple masts (variant), an incorrect extension sequence may occur, i.e. the inner lift mast may extend before the free lift has finished. As a result, the overall height is exceeded and damage may occur in passageways or from low ceilings.

An incorrect extension sequence may, for instance, result from:

- The hydraulic oil temperature being too low.
 - The fork carriage becoming blocked in the inner lift mast.
 - Blocking of the free lift cylinder.
 - The chain roller becoming blocked at the free lift cylinder.
- If the hydraulic oil temperature is too low, slowly actuate the lift mast functions several times in order to raise the oil temperature.

In the event that the fork carriage is blocked in the inner lift mast, or the free lift cylinder or chain roller are blocked, the cause of the blockage must be eliminated before resuming work.

- Notify your service centre

Load chains not under tension

⚠ DANGER

Danger caused by a falling load!

- Make sure that the chain(s) does (do) not become slack when lowering the load.

Slack chains can, for instance, result from:

- Resting the fork carriage or the load on the racking.
- Fork carriage rollers becoming blocked in the lift mast due to contamination.
- If the fork carriage or the load comes to an unexpected stop, lift the fork carriage until the chains are under tension again and lower the load at another suitable location.
- If the fork carriage rollers in the lift mast become blocked due to contamination, lift the fork carriage until the chains are under tension again. Remove the contamination before resuming work.

⚠ WARNING

Risk of injury!

- Observe the safety regulations for working on lift masts; see → Chapter "Working at the front of the truck", P. 5-314.

Hydraulic blocking function

The hydraulic blocking function ensures that all the functions of the working hydraulics are disabled whenever the seat switch in the driver's seat is unloaded.

If the driver stands up from the driver's seat, the blocking function prevents the hydraulic functions that:

- Lift the load
- Lower the load
- Tilt the lift mast
- Additional functions

Releasing the block on the hydraulics

Proceed as follows to release the block on the hydraulics:

4

Operation

Lifting

- Sit down on the driver's seat.

All the relevant functions of the working hydraulics will be available again.

 NOTE

If it is not possible to release the block on the hydraulics when the load is raised because of a technical fault, the load must be lowered using the "emergency lowering" mechanism before any further action is taken. Do not operate the truck again until the fault has been rectified by the authorised service centre.

Lifting system operating devices

The method of operating the lifting system depends on the operating devices included in the truck's equipment.

Possible equipment variants include:

- Double mini-lever
 - Triple mini-lever
 - Quadruple mini-lever
 - Joystick 4Plus
 - Fingertip switch
- The following information must be observed regardless of the equipment variant:

 **DANGER**

Reaching into or climbing between moving parts of the truck (e.g. lift mast, sideshifts, working equipment, load carrying devices etc.) can lead to serious injury or death and is therefore prohibited.

- Observe the safety regulations for handling loads.
- Only operate the lifting system from the driver's seat.

Controlling the lifting system using a double mini-lever

⚠ DANGER

Reaching into or climbing between moving parts of the truck (e.g. lift mast, sideshifts, working equipment, load carrying devices etc.) can lead to serious injury or death and is therefore prohibited.

- Observe the safety regulations for handling loads.
- Only operate the lifting system from the driver's seat.

Lifting/lowering the fork carriage

To lift fork carriage:

- Move the "lift mast" 360° lever (1) in the direction of arrow (B).

To lower fork carriage:

- Move the "lift mast" 360° lever (1) in the direction of arrow (A).

Tilting the lift mast

To tilt the lift mast forwards:

- Move the "lift mast" 360° lever (1) in the direction of arrow (C).

To tilt the lift mast backwards:

- Move the "lift mast" 360° lever (1) in the direction of arrow (D).

i NOTE

The symbols on the 360° lever show the direction of movement of the lift mast and the fork carriage when the 360° lever is moved.

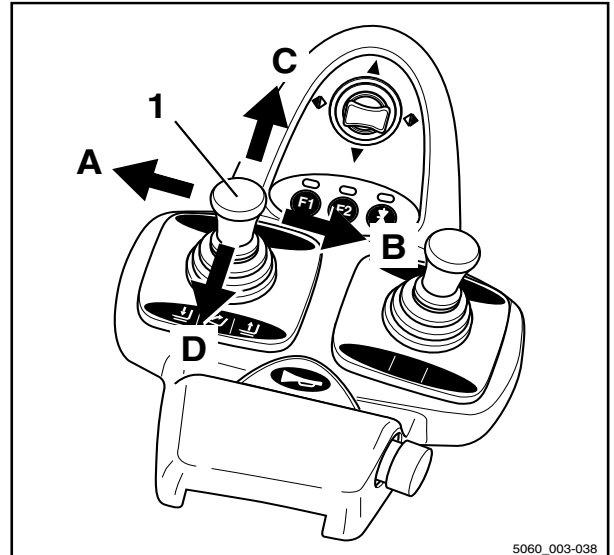

5060_003-038

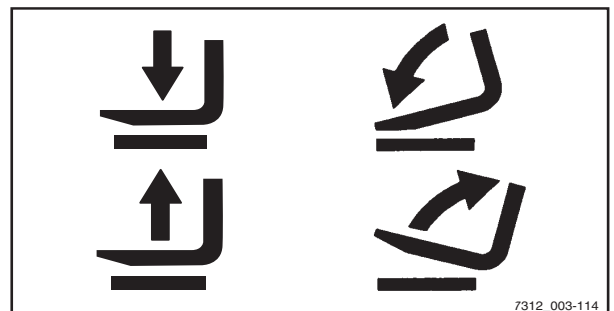

7312_003-114

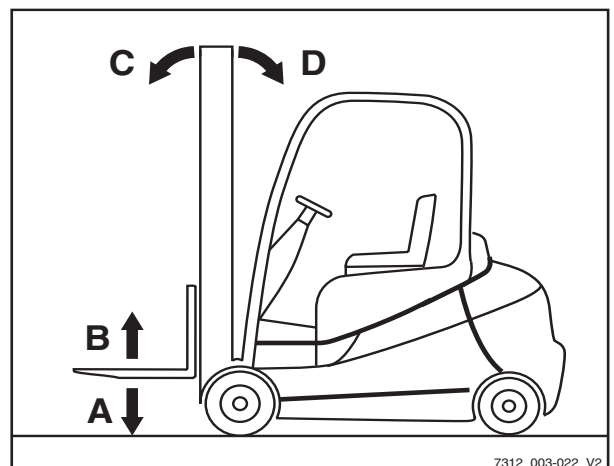

7312_003-022_V2

4 Operation

Lifting

Controlling the lifting system using a triple mini-lever

⚠ DANGER

Reaching into or climbing between moving parts of the truck (e.g. lift mast, sideshifts, working equipment, load carrying devices etc.) can lead to serious injury or death and is therefore prohibited.

- Observe the safety regulations for handling loads.
- Only operate the lifting system from the driver's seat.

Lifting/lowering the fork carriage

To lift fork carriage:

- Move the "lift mast" 360° lever (1) in the direction of arrow (B).

To lower fork carriage:

- Move the "lift mast" 360° lever (1) in the direction of arrow (A).

Tilting the lift mast

To tilt the lift mast forwards:

- Move the "lift mast" 360° lever (1) in the direction of arrow (C).

To tilt the lift mast backwards:

- Move the "lift mast" 360° lever (1) in the direction of arrow (D).

i NOTE

The symbols on the 360° lever show the direction of movement of the lift mast and the fork carriage when the 360° lever is moved.

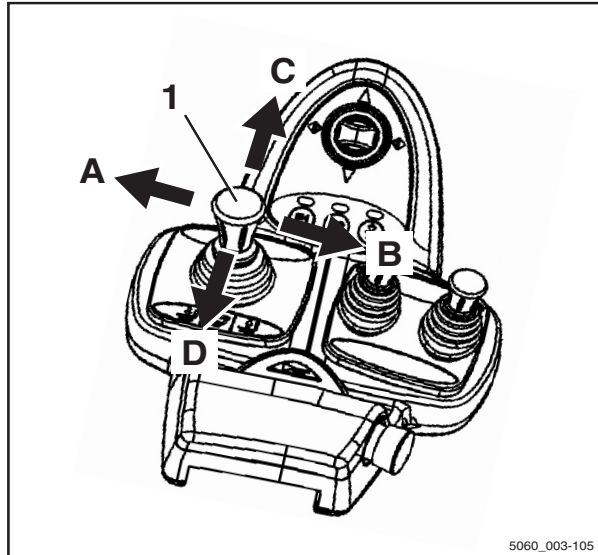

5060_003-105

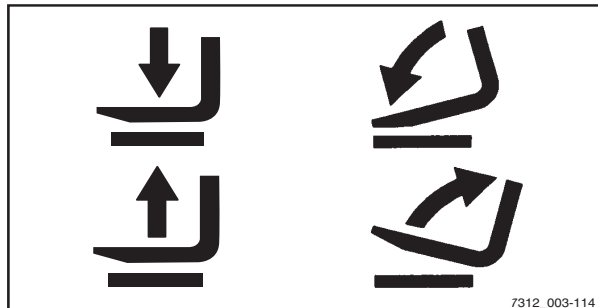

7312_003-114

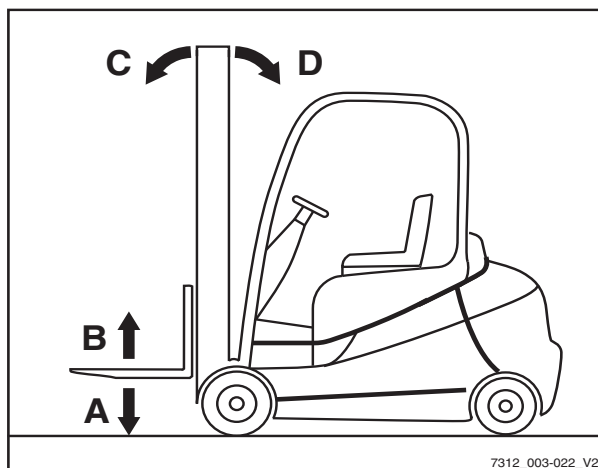

7312_003-022_V2

Controlling the lifting system using a quadruple mini-lever

⚠ DANGER

Reaching into or climbing between moving parts of the truck (e.g. lift mast, sidershifts, working equipment, load carrying devices etc.) can lead to serious injury or death and is therefore prohibited.

- Observe the safety regulations for handling loads.
- Only operate the lifting system from the driver's seat.

Tilting the lift mast

To tilt the lift mast forwards:

- Move the "lift mast" operating lever (1) in the direction of the arrow (A).

To tilt the lift mast backwards:

- Move the "lift mast" operating lever (1) in the direction of the arrow (B).

Lifting/lowering the fork carriage

To lift fork carriage:

- Move the "lift-lower" operating lever (2) in the direction of arrow (D).

To lower fork carriage:

- Move the "lift-lower" operating lever (2) in the direction of arrow (C).

i NOTE

The symbols on the operating levers show the direction of movement of the lift mast or fork carriage when the operating lever is moved.

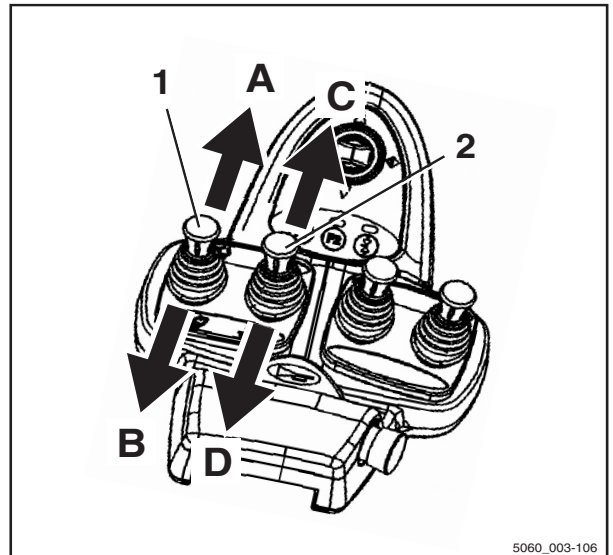

5060_003-106

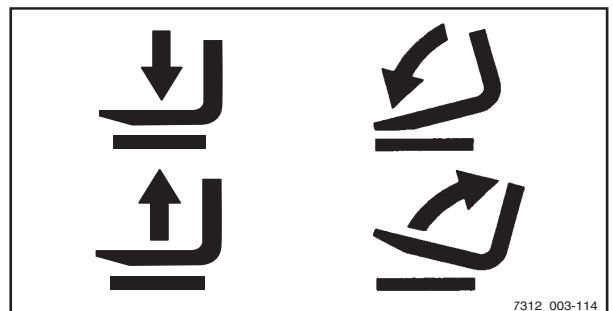

7312_003-114

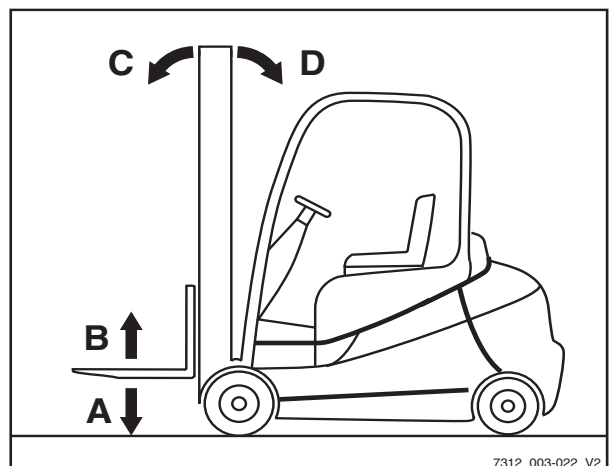

7312_003-022_V2

4 Operation

Lifting

Controlling the lifting system using the joystick 4Plus

⚠ DANGER

Reaching into or climbing between moving parts of the truck (e.g. lift mast, sideshifts, working equipment, load carrying devices etc.) can lead to serious injury or death and is therefore prohibited.

- Observe the safety regulations for handling loads.
- Only operate the lifting system from the driver's seat.

Lifting/lowering the fork carriage

To lift the fork carriage:

- Pull the joystick 4Plus (1) backwards (B).

To lower the fork carriage:

- Push the joystick 4Plus (1) forwards (A).

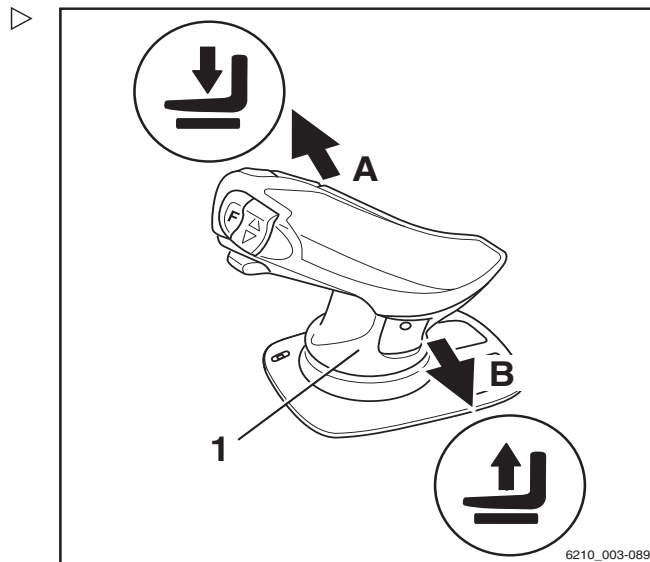

Operation

4

Lifting

Tilting the lift mast

To tilt the lift mast forwards:

- Tilt the horizontal rocker button (2) to the left (C).

To tilt the lift mast backwards:

- Tilt the horizontal rocker button (2) to the right (D).

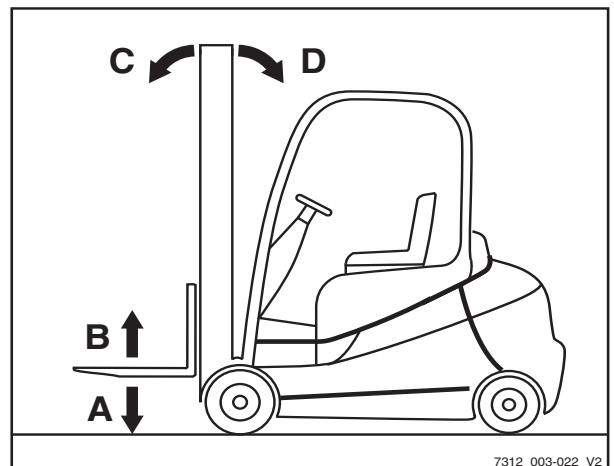
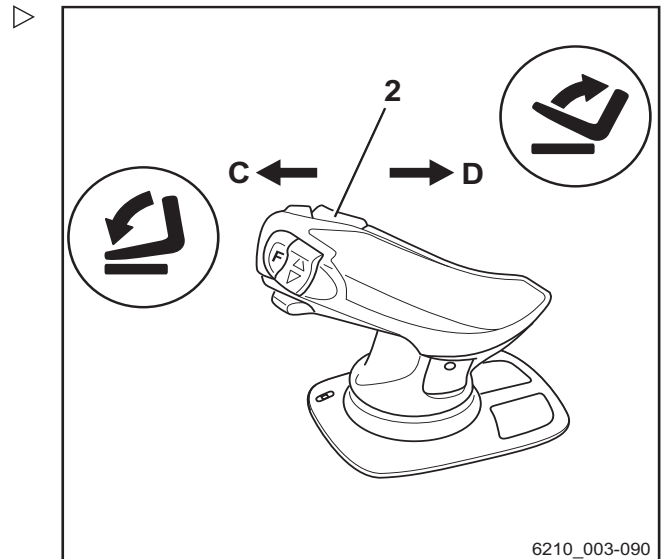

Fork-carriage sideshift

To move the fork carriage to the left.

- Push the joystick 4Plus (1) to the left (E).

To move the fork carriage to the right:

- Push the joystick 4Plus (1) to the right (F).

i NOTE

The symbols on the joystick 4Plus indicate the direction of movement of the lift mast or the fork carriage.

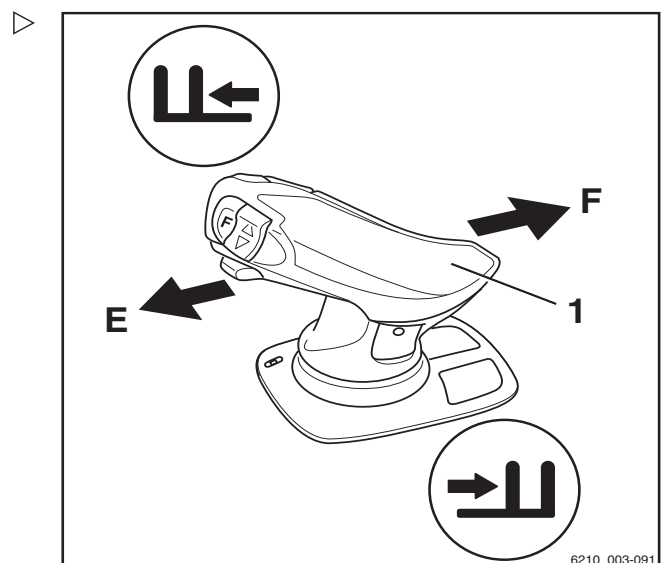

4 Operation

Lifting

Controlling the lifting system with the fingertip console

⚠ DANGER

Reaching into or climbing between moving parts of the truck (e.g. lift mast, sideshifts, working equipment, load carrying devices etc.) can lead to serious injury or death and is therefore prohibited.

- Observe the safety regulations for handling loads.
- Only operate the lifting system from the driver's seat.

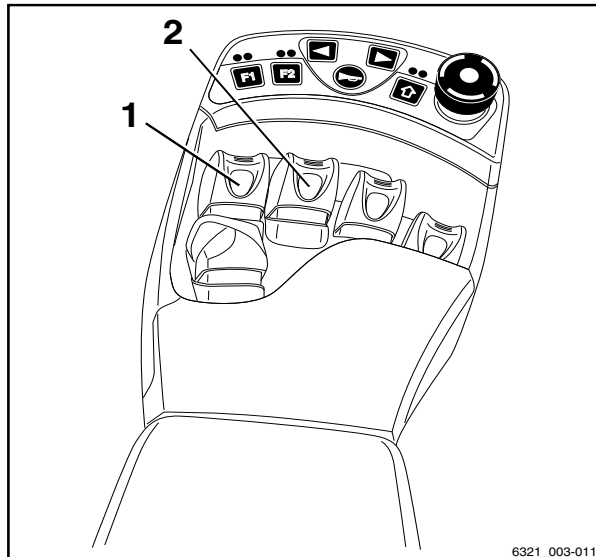

Lifting/lowering the fork carriage

To lift fork carriage:

- Pull the "lift/lower" operating lever (1) backwards.

To lower fork carriage:

- Push the "lift/lower" operating lever (1) forwards.

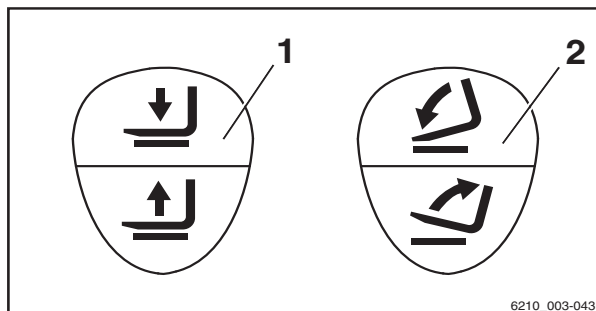

Tilting the lift mast

To tilt the lift mast forwards:

- Push the "tilt" operating lever (2) forwards.

To tilt the lift mast backwards:

- Pull the "tilt" operating lever (2) backwards.

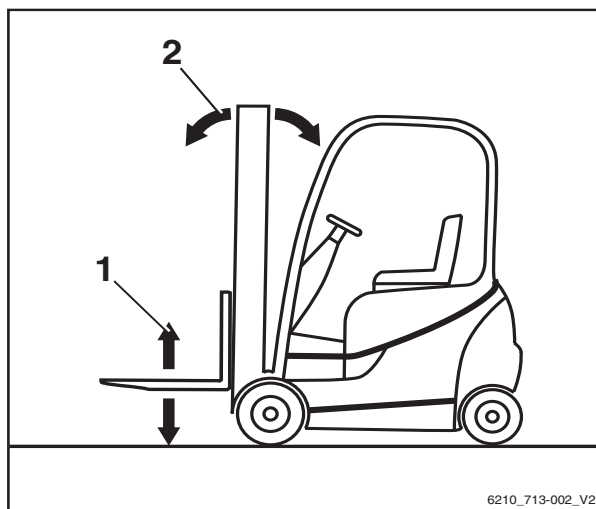

i NOTE

The symbols on the operating levers show the direction of movement of the lift mast or fork carriage when the operating lever is moved.

Changing the fork arms

DANGER

Risk of fatal injury from being run over if the truck rolls away!

- Do not park the truck on a gradient.
- Apply the parking brake.
- Change the fork arms in a separate, safe location on a level surface.

WARNING

There is a risk of injury when changing the fork arms; the weight of the fork arms could cause them to fall on your legs, feet or knees. The space to the left and right of the fork is a danger area.

- Always wear protective gloves and safety footwear when changing the fork arms.
- Ensure that no one stands in the danger area!
- Do not pull on the fork arms.
- The fork arms must always be carried by two people; if necessary, use a hoist.

NOTE

- *For installation and removal, a transport pallet is recommended for supporting the fork arms. The pallet size depends on the fork arm size used and should be dimensioned such that the fork arms do not protrude after being placed on the pallet. This means the fork arms can be safely placed down and transported.*
- *Both fork arms can be pushed over to the same side. It is possible to choose the side via which the forks are removed*

4

Operation

Lifting

Removal

- Select a pallet corresponding to the fork arm size.
- Set down the pallet next to the fork carriage on the side chosen for removal.
- Lift the fork carriage until the fork arms are approx. 3 cm above the pallet.
- Apply the parking brake.
- Remove the switch key.
- Unscrew the locking screw (2) on the side chosen for removal.
- Pull up the locking lever (1) and push the fork arms onto the pallet one after the other.

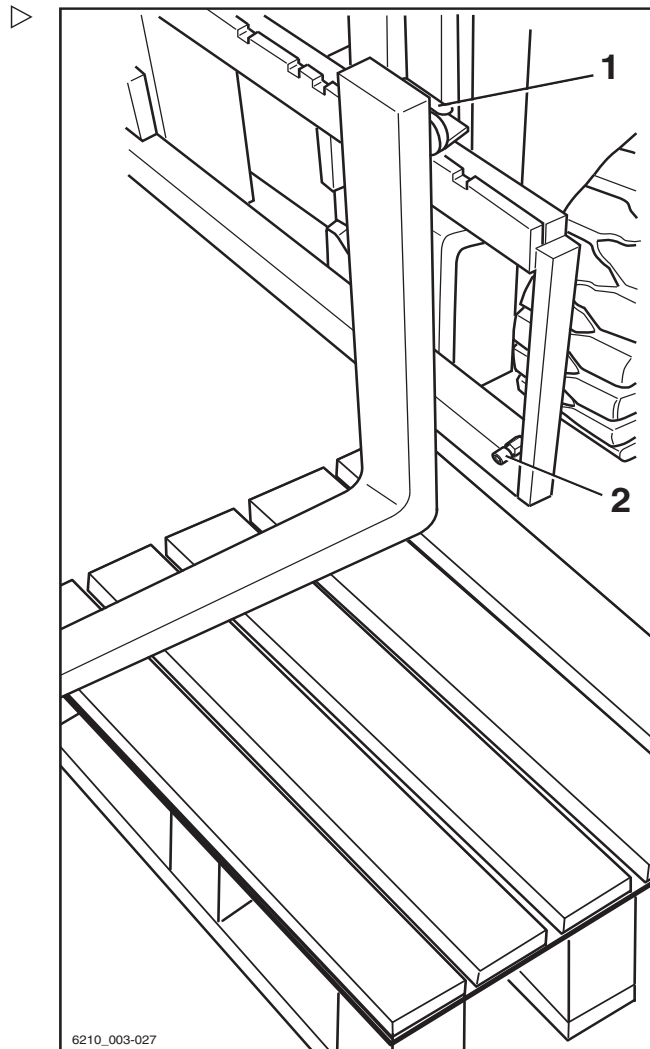

Installation

- Make sure that the locking screw is unscrewed on the side chosen for installation.
- Place the fork arms on a pallet next to the fork carriage on the side chosen for installation.
- Pull up the locking lever (1) and push the fork arms onto the fork carriage one after the other.
- Place the fork arms in the required position and push down the locking lever. Ensure that the locking lever snaps into place.
- Screw in and tighten the locking screw (2).

⚠ DANGER

There is a risk of fatal injury from a falling load or fork!

- Tighten the locking screw each time a fork is changed.
- Driving and moving loads without the locking screw is prohibited.

i NOTE

If the truck is equipped with the "load measurement" comfort feature, a "zero adjustment of the load measurement" must always be performed after the fork arms have been chan-

ged. Otherwise, correct load measurement cannot be guaranteed.

Fork extension (variant)

⚠ DANGER

There is a risk of being run over if the truck rolls away and therefore a danger to life.

- Do not park the truck on a slope.
- Apply the parking brake.
- Change the fork extension in a separate, safe location on a level surface.

⚠ WARNING

There is a risk of crushing!

The weight of the fork extension can cause crushing or cuts on sharp edges or burrs.

- Always wear protective gloves and safety footwear.

⚠ WARNING

There is a risk of tipping!

The weight and dimensions of the fork extension affect the stability of the truck. The permissible weights stated on the capacity rating plate must be reduced in proportion to the actual load distance.

The truck is equipped with a fork extension ex works, the capacity rating plate is already adjusted accordingly.

- Observe load capacity, see the "Before picking up a load" chapter.

i NOTE

If the truck is equipped with the "load measurement" comfort feature, a "zero adjustment of the load measurement" must always be performed after the fork extensions have been changed. Otherwise, correct load measurement cannot be guaranteed.

4 Operation
Lifting

Attachment

⚠ DANGER

Risk to life from falling load!

At least 60% of the length of the fork extension must lie on the fork arm. A maximum 40% overhang over the fork arm end is permissible. The fork extension must also be secured against slipping from the fork arm.

If the fork extension (1) is not secured with a securing bolt (2) and lynch pin (3), the load with the fork extension may fall.

- Push the fork extension completely to the back of the fork.
 - Make sure that 60% of the length of the fork extension is on the fork arm.
 - Always secure the fork extension with a securing bolt.
 - Always secure the securing bolt with a lynch pin.
-
- Remove the lynch pin (3) from the securing bolt (2).
 - Remove the securing bolt from the fork extension (1).
 - Push the fork extension onto the fork arms until it is flush with the fork back.
 - Insert the securing bolts located behind the fork back fully into the fork extension.
 - Insert the lynch pin into the securing bolt and secure.

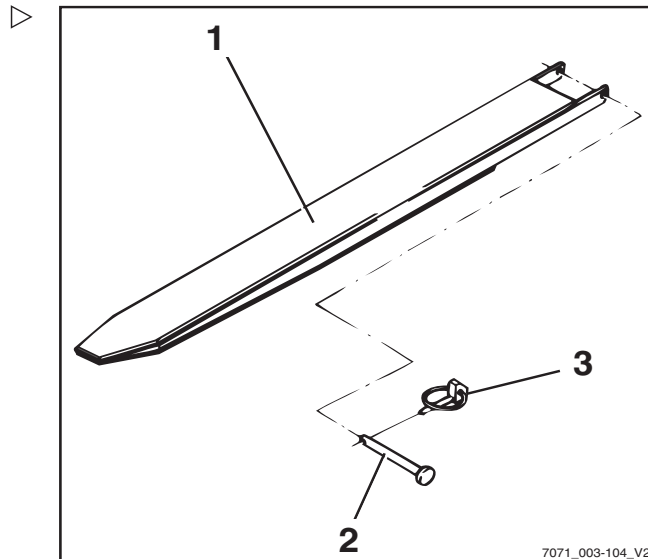

7071_003-104_V2

Removal

- Remove the lynch pin (3) from the securing bolt (2).
- Remove the securing bolt from the fork extension (1).
- Pull the fork extension from the fork arms.
- Insert the securing bolt fully into the fork extension.
- Insert the lynch pin into the securing bolt and secure.

Operation with reversible fork arms (variant) ▷

⚠ DANGER

Risk to life from falling load!

Standard fork arms are not structurally designed for reverse operation. If this instruction is not observed, it can lead to material failure and the load falling.

- Only work in reverse operation using reversible fork arms (1)

⚠ WARNING

Risk of accident from slipping load!

Loads may slip on the reversible fork arms if there is no load support. A fork extension (variant) cannot be secured against slipping.

- Do not use a fork extension (variant)

⚠ WARNING

Risk of accident from the truck tipping over.

When driving, the centre of gravity of the load (2) must not be higher than 600 mm above the ground. The truck may tip forwards when driving or braking.

- Only drive with a load centre of gravity up to a max. of 600 mm above the ground

i NOTE

If the truck is equipped with the "load measurement" comfort feature, a "zero adjustment of the load measurement" must always be performed after the reversible fork arms have been changed. Otherwise, correct load measurement cannot be guaranteed.

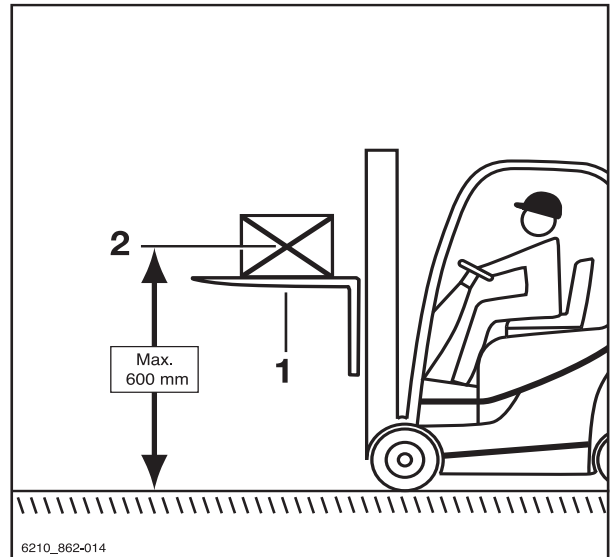

4 Operation
Lifting

Reversible fork arms (1) can be used to reach an additional lift height. The reversible fork arms are installed on the fork carriage in the same manner as standard fork arms. Loads may be lifted on and beneath the reversible fork arms. The mast is lifted and tilted in the same manner.

- Only work in reverse operation using reversible fork arms
- Do not use a fork extension (variant)
- If the "load measurement" comfort feature is available, perform a "zero adjustment of the load measurement"
- To drive, raise the load centre of gravity (2) to a max. of 600 mm above the ground
- Observe the information in the section entitled "Transporting suspended loads"

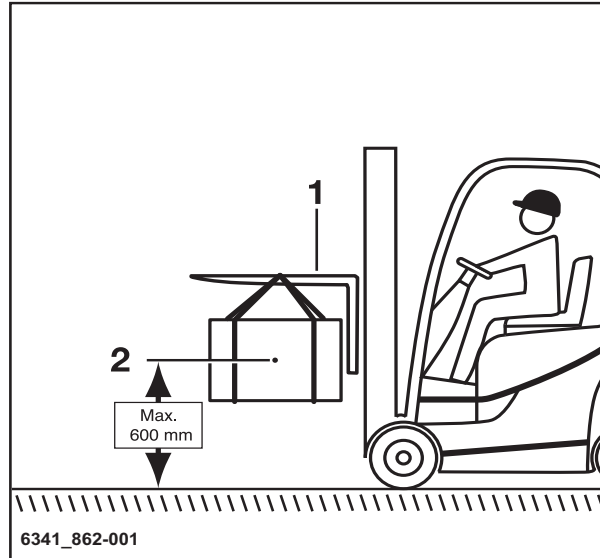

Handling loads

Safety regulations when handing loads

The safety regulations for handling loads are shown in the following sections.

⚠ DANGER

There is a risk to life caused by falling loads or if parts of the truck are being lowered.

- Never walk or stand underneath suspended loads or raised fork arms.
- Never exceed the maximum load indicated on the capacity rating plate. Otherwise stability cannot be guaranteed!

⚠ DANGER

Risk of accident from falling or crushing!

- Do not step onto the forks.
- Do not lift people.
- Never grab or climb on moving parts of the truck.

⚠ DANGER

Risk of accident from a falling load!

- When transporting small items, attach a load safety guard (variant) to prevent the load from falling on the driver.
- Use a closed roof covering (variant) in addition.



4

Operation

Handling loads

Before taking up load

Load capacity

The load capacity indicated for the truck on the capacity rating plate may not be exceeded. The load capacity is influenced by the load centre of gravity and the lift height as well as by the tyres, if applicable.

The position of the capacity rating plate can be found in the chapter entitled "Identification points".

⚠ WARNING

The figures show examples.
Only the capacity rating plates on the truck are valid!

The attachment of additional weights to increase load capacity is prohibited.

⚠ DANGER

Risk to life from the truck losing stability!

Never exceed the maximum loads shown! These values apply to compact and homogenous loads. Otherwise, the stability as well as the rigidity of the fork arms and lift mast cannot be guaranteed.

Improper or incorrect operation or the placement of persons to increase load capacity is prohibited.

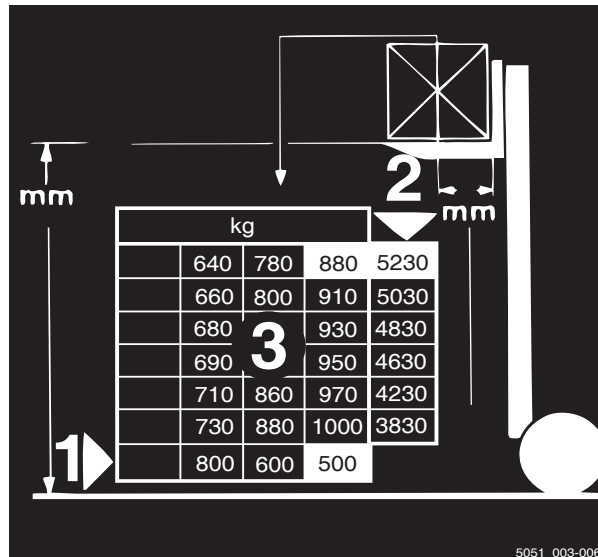

Operation

4

Handling loads

Example

Weight of load to be lifted: 880 kg (3)

Load distance from fork back: 500 mm (1)

Permitted lift height: 5230 mm (2)

⚠ WARNING

Risk of accident from the truck losing stability!

The permissible load of the attachments (variant) and the reduced lifting capacity of the combination of truck and attachment must not be exceeded.

- Observe the special capacity rating plate information shown on the truck and the attachment.

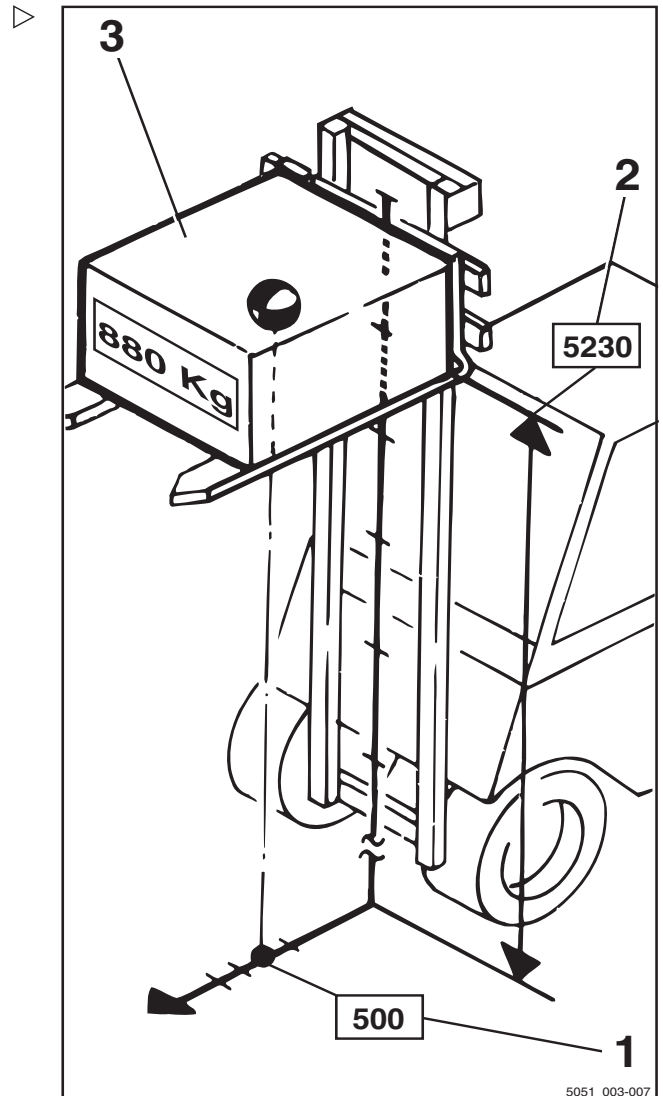

Load measurement (variant)

Description

Knowing the weight of the load to be transported gives the driver greater security. If the truck is equipped with the "load measurement" (variant) comfort feature, the weight of the lifted load can be measured and shown in the display and operating unit.

Load measurement is possible only when the truck is at a standstill. Before performing a load measurement, the load must be raised to a height of 300-800 mm above the ground.

Handling loads

The load measurement has an accuracy of +/-3% of the rated capacity of the truck.

NOTE

In order to ensure accuracy at all times, a zero adjustment of the load measurement must be carried out. Zero adjustment is required.

- *as part of daily commissioning*
- *after changing the fork arms*
- *after fitting or changing attachments.*

Performing the load measurement

DANGER

Risk of accident from a falling load!

The load may fall if the load centre of gravity has not been taken into account or the load has not been picked up securely.

- Pick up the load securely; see the chapter entitled "Picking up loads".

CAUTION

If the weight determined by a load measurement exceeds the permissible residual load capacity of the truck, the truck cannot be operated safely.

- Set down and reduce load immediately.
- If necessary, use another truck with sufficient load-bearing capacity.

NOTE

Accurate load measurement is only possible under the following conditions:

- *The hydraulic oil is at normal operating temperature*
- *The load is at rest at the beginning of the load measurement*
- *The load corresponds to at least 10% of the nominal load capacity in trucks with a load capacity of up to 2.5 t*
- *The load corresponds to at least 5% of the nominal load capacity in trucks with a load capacity of 3 t and over*
- *The lift mast is in the vertical position*
- *The fork is not raised to more than 800 mm above the ground*

i NOTE

The method of operating the lifting system depends on the operating devices included in the truck's equipment.

- Ensure that the truck has been in operation for a period of time before carrying out the load measurement.
- Set lift mast to vertical.
- Raise the fork to a height of 300–800 mm.
- Ensure that the load is at rest.
- Press Softkey  (1).

Load measurement is switched on.
The  (2) symbol is displayed.

i NOTE

*If the truck is equipped with mini-levers or fingertip operation, the **F1** button can also be pressed as an alternative.*

i NOTE

During the following process, the fork carriage must be lowered slightly and then stopped abruptly. While doing so, the fork must not touch the ground, otherwise the load measurement will not be accurate. To stop the lowering procedure quickly, release the operating device for lowering so that it jumps into the zero position.

- Lower the fork carriage slightly and release the operating device.

i NOTE

When stopping the lowering process the load must be cushioned in order to create a measurable impulse.

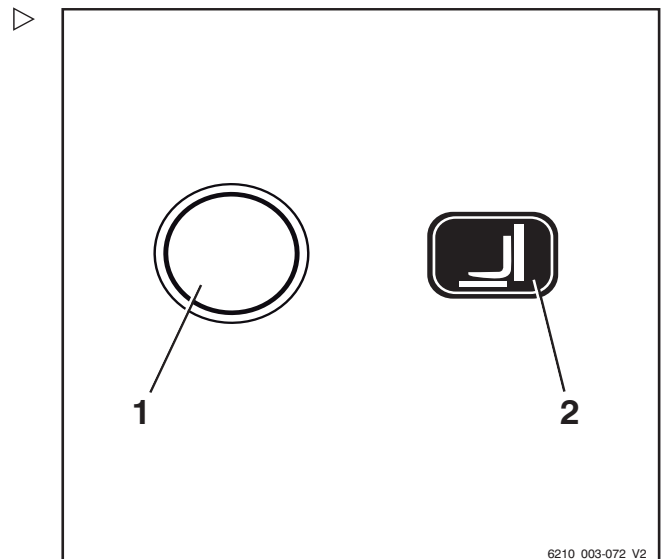

6210_003-072_V2

4

Operation

Handling loads

When load measurement has been performed correctly, the determined load weight (3) is shown on the display.

i NOTE

If the load measurement is invalid, the value "-9999 kg" is displayed in the operating unit.

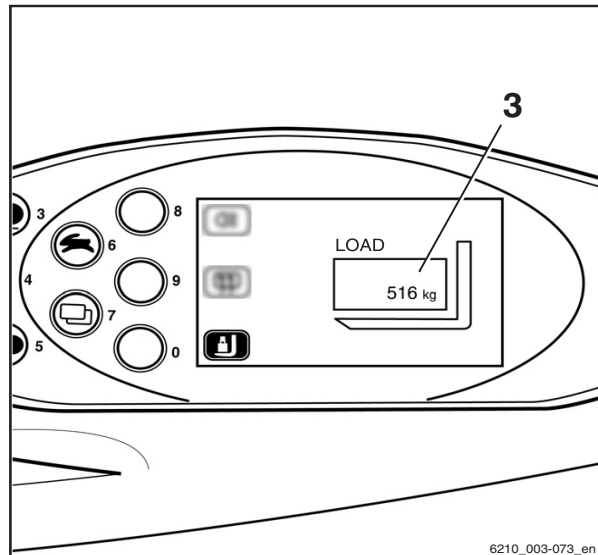

Picking up loads

To make sure that the load is securely supported, it must be ensured that the fork arms are sufficiently far apart and are positioned as far as possible under the load.

If possible, the load should rest on the back of the fork.

The load must not protrude too far over the fork tips, nor should the fork tips protrude too far out from the load.

Loads are to be picked up and transported as close to the middle as possible.

⚠ DANGER

Risk of accident from a falling load!

When transporting small items, attach a load safety guard (variant) to prevent the load from falling on the driver.

A closed roof covering (variant) should also be used.

Removable roof panels may not be removed.

Adjusting the fork

- Lift the locking lever (1) and move the fork arms to the desired position.
- Allow the locking lever to snap back into place.

The load centre of gravity must be midway between the fork arms.

- Only actuate the fork prong positioner (variant) when the fork is not carrying a load.

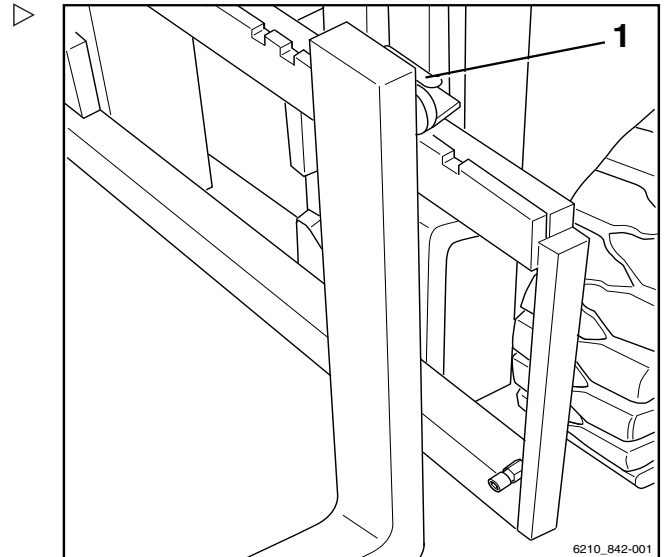

Danger area

The danger area is the area in which people are at risk due to the movements of the truck, its working equipment, its load-carrying equipment (e.g. attachments) or the load. Also included are the areas where loads could fall or working equipment could fall or be lowered.



⚠ DANGER

Risk of injury!

- Do not step on the fork.



⚠ DANGER

Risk of injury!

- Do not step under the raised forks.

⚠ DANGER

People may be injured in the danger area of the truck!

The danger area of the truck must be completely clear of all personnel, except the driver in his normal operating position. If persons fail to leave the danger area despite warnings:

- Cease work with the truck immediately.
- Secure the truck against use by unauthorised parties.

4 Operation

Handling loads



! DANGER

Danger of death from falling loads!

- Never walk or stand underneath suspended loads.

Transporting pallets

As a rule, loads (e.g. pallets) must be transported individually. Transporting multiple loads at the same time is only permitted:

- when instructed by the supervisor and
- when the technical requirements have been met.

The driver must ensure proper condition of the load. Only safely and carefully positioned loads may be transported.

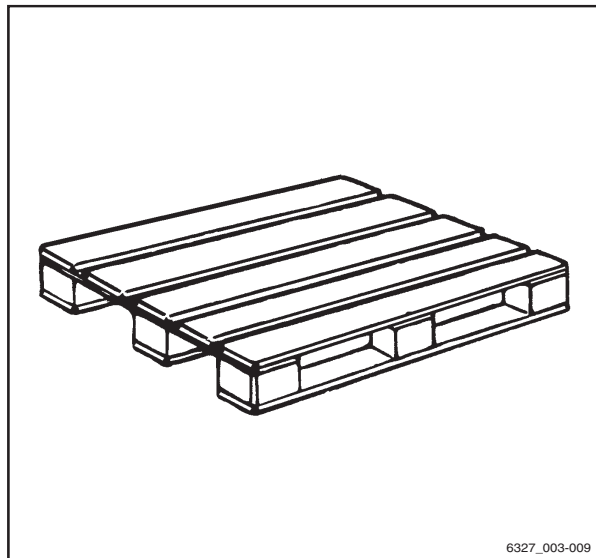

6327_003-009

Transporting suspended loads

Before transporting suspended loads, consult the national regulatory authorities (in Germany, the employer's liability insurance associations).

National regulations may place restrictions on these operations. Contact the relevant authorities.

! DANGER

Suspended loads that begin to swing can result in the following risks:

- Impaired braking and steering action
- Tipping over the load wheels or drive wheels
- Tipping the truck at right angles to the direction of travel
- Risk of crushing of guide persons
- Reduced visibility.



6210_001-007

⚠ DANGER

Loss of stability.

Slipping or swinging suspended loads can lead to a loss of stability and cause the truck to tip over.

- When transporting suspended loads, observe the following instructions

Instructions for transporting suspended loads:

- Swinging loads must be prevented by using the proper driving speed and driving style (careful steering, braking)
- Hanging loads must be hooked on to the truck in such a way that the harness cannot shift or release unintentionally and cannot be damaged
- When transporting suspended loads, suitable devices (e.g. guy wires or supporting poles) must be available so that accompanying persons can guide suspended loads and prevent the loads from swinging
- Take particular care to ensure that there is no one in the drive direction in the driving lane
- If, despite this, the load begins to swing, ensure that no person is placed at risk

⚠ DANGER

Risk of accidents!

When transporting hanging loads, never perform or end driving and load movements abruptly.

Never drive on slopes with a suspended load.

Transporting containers holding fluids as hanging loads is not permitted.

Load pick up

⚠ DANGER

There is a risk to life caused by a falling load or if parts of the truck are being lowered.

- Never walk or stand underneath suspended loads or raised fork arms.
 - Never exceed the maximum load values specified on the capacity rating plate. Otherwise, stability cannot be guaranteed.
-
- Only store pallets which do not exceed the specified maximum size. Damaged loading

4 Operation

Handling loads

equipment and incorrectly formed loads must not be stored.

- Attach or secure the load to the load-carrying equipment so that the load cannot move or fall.
- Store the load so that the specified aisle width is not reduced by protruding parts.
- Approach the racking carefully, brake gently and stop just in front of the racking. ▷

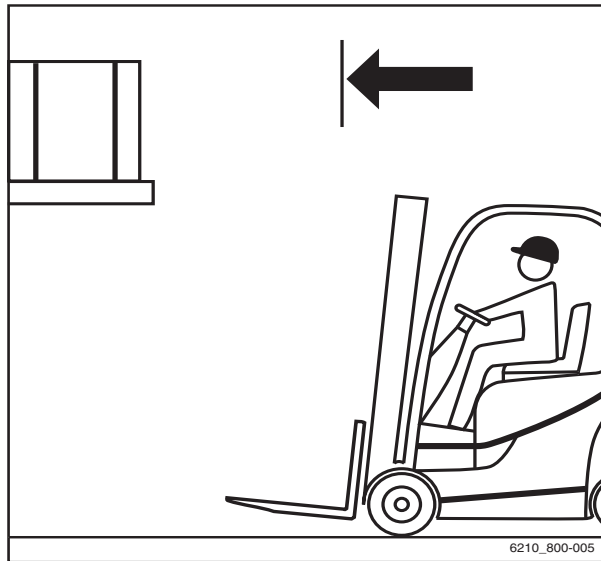

- Position the forks.
- Set lift mast to vertical.
- Lift the fork carriage to the stacking height. ▷

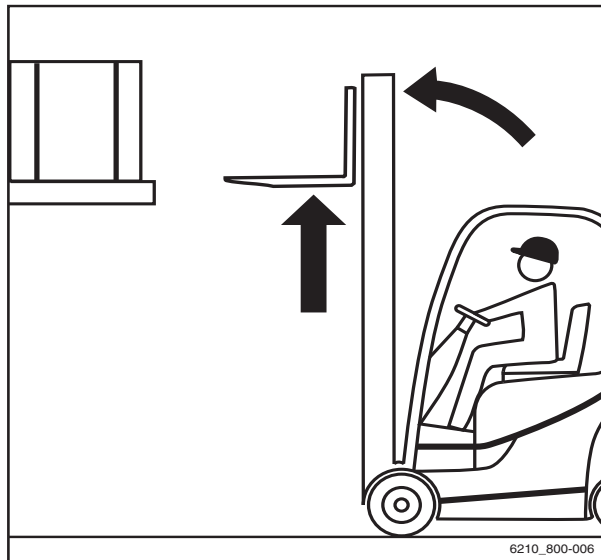

⚠ CAUTION

Component damage possible!

When inserting the fork into the racking, ensure that the racking and load are not damaged.

Operation

4

Handling loads

- Insert the fork as far under the load as possible. Stop the truck as soon as the fork back is resting on the load. The centre of gravity of the load must be positioned between the fork arms in the middle.

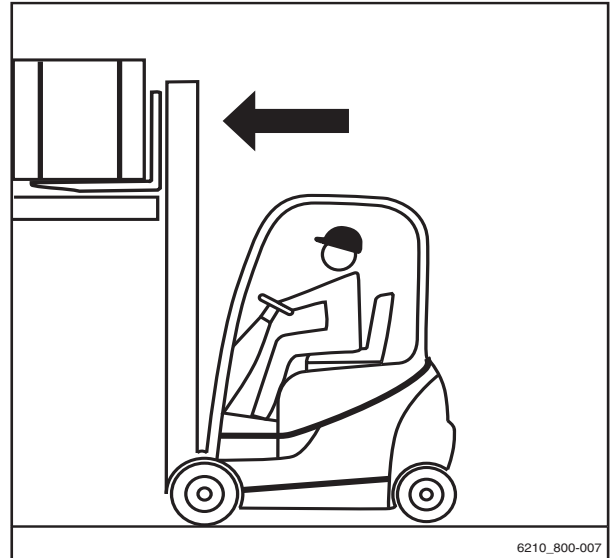

6210_800-007

- Lift the fork carriage until the load is resting entirely on the forks.

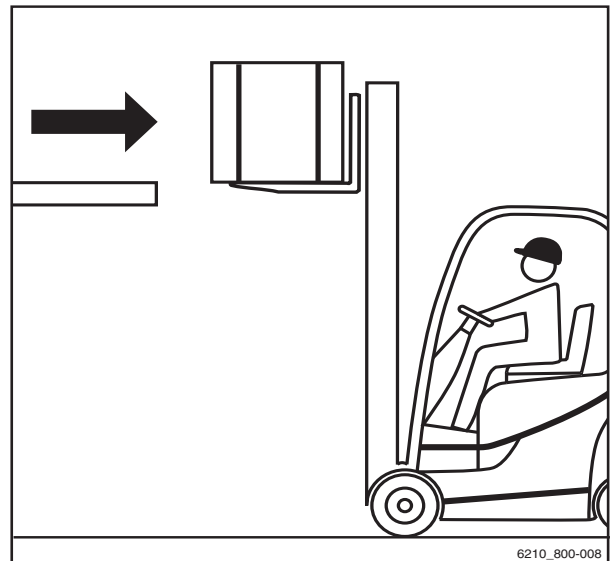

6210_800-008

⚠ DANGER

Risk of accidents!

- Beware of any people in the danger area.
- Ensure that the roadway behind you is clear.

⚠ DANGER

Never tilt the lift mast with a raised load due to the risk of tipping!

- Lower the load before tilting the lift mast.
- Move backwards carefully and slowly until the load is clear of the racking. Brake gently.

4 Operation

Handling loads

- Lower the load while maintaining ground clearance.

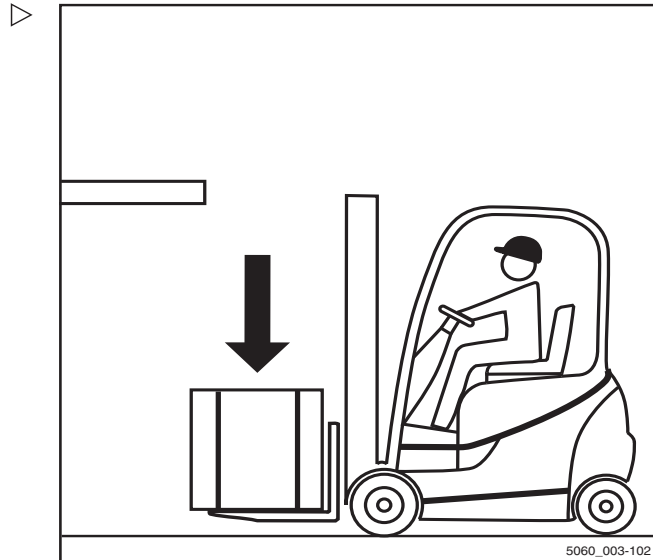

- Tilt the lift mast backwards.
The load can be transported.

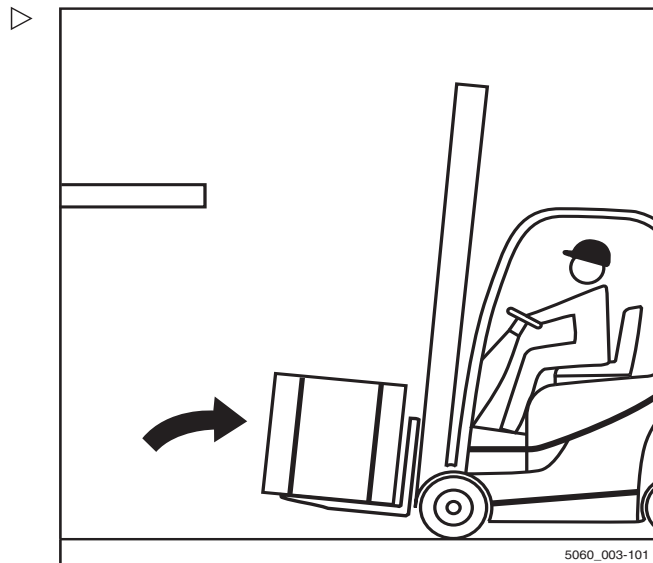

Transporting loads

i NOTE

Observe the information in the chapter entitled "Safety regulations when driving".

⚠ DANGER

The higher a load is lifted, the less stable it becomes. The truck can tip over or the load can fall, increasing the risk of accident!

Driving with a raised load and the lift mast tilted forward is not permitted.

- Only drive with the load lowered.
- Lower the load until ground clearance is reached (not over 300 mm).
- Only drive with the lift mast tilted backwards.

- Drive slowly and carefully round corners!

i NOTE

Observe the information in the chapter entitled "Steering".

- Always accelerate and brake gently!

i NOTE

Observe the information in the chapter entitled "Operating the service brake".

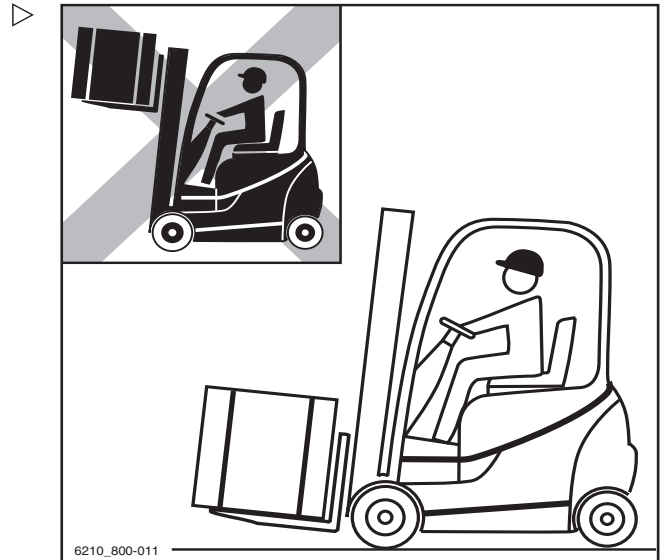

4 Operation

Handling loads

- Never drive with a load protruding to the side (e.g. with the sideshift)!

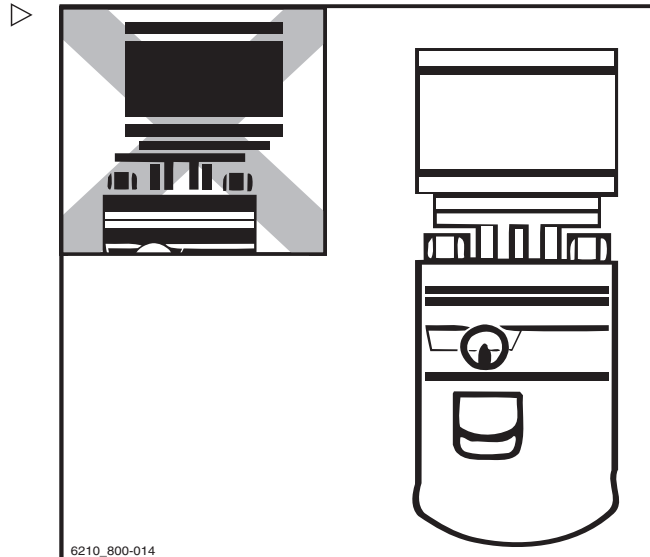

Setting down loads

⚠ DANGER

Risk of accident due to changed moment of tilt!

The load centre of gravity and the moment of tilt move due to tilting the lift mast forwards with a raised load or due to the load slipping. The truck may tip forwards.

- Only tilt the lift mast forwards with a raised lifting accessory when it is directly above the stack.
- When the lift mast is tilted forwards, take particular care to ensure that the truck does not tip forwards and that the load does not slip.

⚠ WARNING

Risk of accident from a falling load!

If the fork or the load remains suspended during lowering, the load may fall.

- When removing from stock, move the truck far enough back so that the load and the fork can be lowered freely.

Operation

4

Handling loads

- Drive up to the stack with the load lowered in accordance with regulations. ▷
- Set lift mast to vertical.
- Lift the load to the stacking height.
- Drive the truck towards the rack carefully.

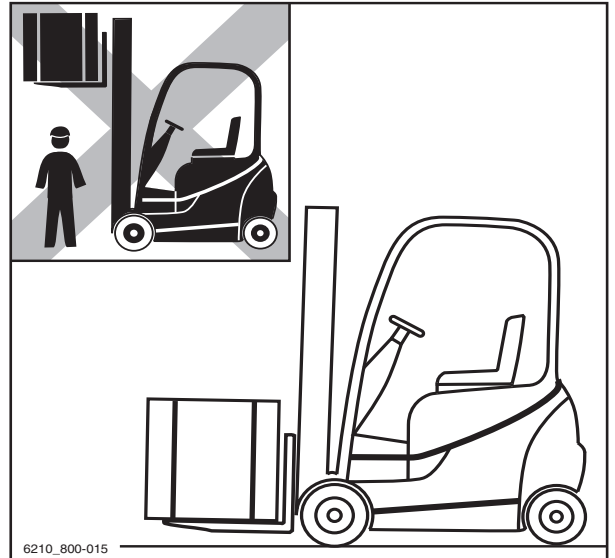

- Lower the load until it rests securely on the rack. ▷

⚠ DANGER

Risk of accident!

- Beware of any people in the danger area.
 - Ensure that the roadway behind you is clear.
-
- Move the truck back until the fork arms can be lowered without touching the stack.
 - Lower the fork while maintaining ground clearance.
 - Tilt the lift mast backwards and drive away.

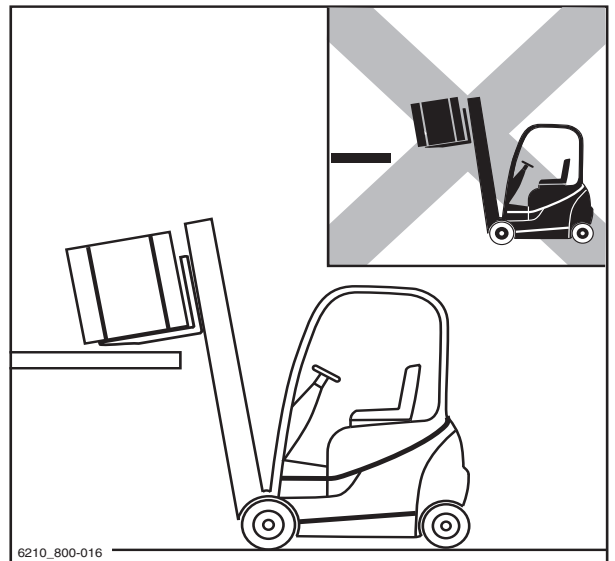

4 Operation

Handling loads

Driving on lifts

The driver is only allowed to use this truck on lifts with a sufficient load capacity and for which the operating company (see ⇒ Chapter "Definition of responsible persons", P. 28) has been granted authorisation.

⚠ DANGER

There is a risk to life from being crushed or run over by the truck.

- There must be no personnel already in the lift when the truck is driven into the lift.
- Personnel are only permitted to enter the lift once the truck is secure, and must exit the lift before the truck is driven out.

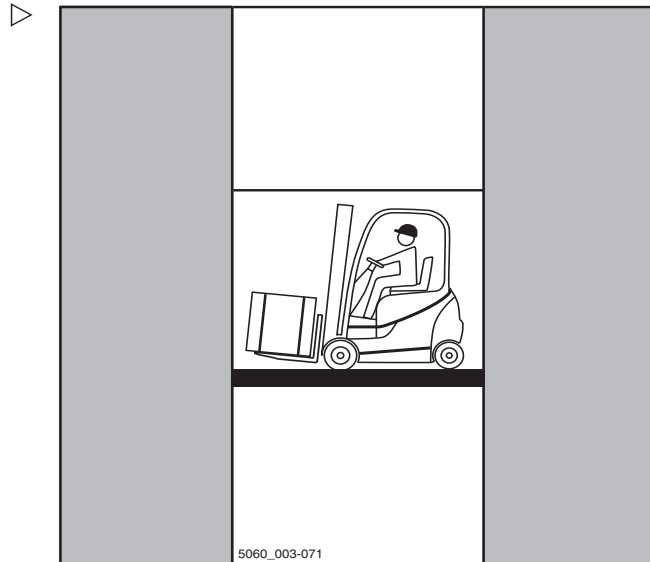

Determining the actual total weight

- Park the truck securely, see ⇒ Chapter "Parking the truck securely and switching it off", P. 4-144.
- Determine the unit weights by reading the truck nameplate and, if necessary, the attachment (variant) nameplate and, if necessary, by weighing the load to be lifted.
- Add the determined unit weights to obtain the actual total weight of the truck:

- Tare weight (1)
- + Max. permissible battery weight (2)
- + Ballast weight (variant) (3)
- + Net weight of attachment (variant)
- + Weight of the load to be lifted
- + 100 kg allowance for the driver
- = Actual total weight

- Drive the truck with the forks forwards into the lift without touching the shaft walls.
- Park the truck securely in the lift, see ⇒ Chapter "Parking the truck securely and switching it off", P. 4-144, to prevent uncontrolled movements of the load or the truck.

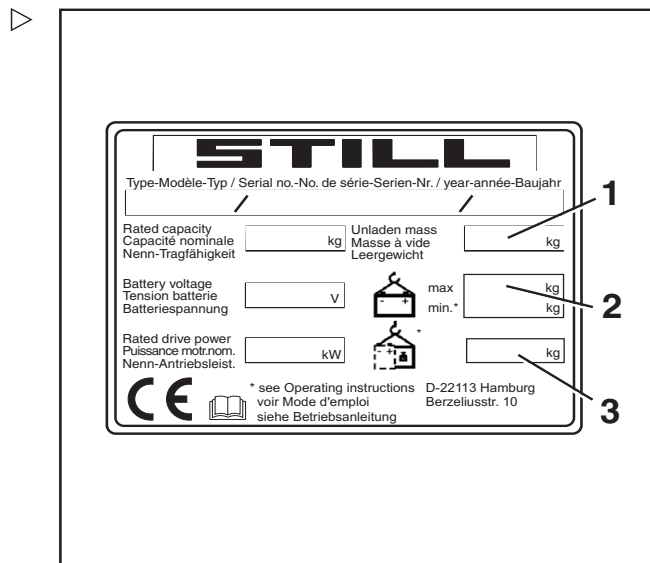

Driving on loading bridges

⚠ DANGER

Risk of accident from the truck crashing!

Steering movements can cause the tail end to veer off the loading bridge towards the edge. This may cause the truck to crash

The lorry driver and the truck driver must agree on the lorry's departure time.

- Establish the departure time of the lorry.
- Determine the total actual weight of the truck.
- Before driving across a loading bridge, ensure that it is properly attached and secured and has a sufficient load capacity (lorry, bridge etc.).
- Ensure that the vehicle onto which you will be driving is secured to prevent it from shifting and that it can support the load of the truck.



Determining the total actual weight

- Park the truck securely.
- Determine the unit weights by reading the truck nameplate and, if necessary, the attachment (variant) nameplate and, if necessary, by weighing the load to be lifted.
- Add the determined unit weights to obtain the total actual weight of the truck:

Tare weight (1)

+ Max. permissible battery weight (2)

+ Ballast weight (variant) (3)

+ Attachment net weight (variant)

+ Weight of the load to be lifted

+ 100 kg allowance for driver

= Total actual weight

- Drive slowly and carefully on the loading bridge.

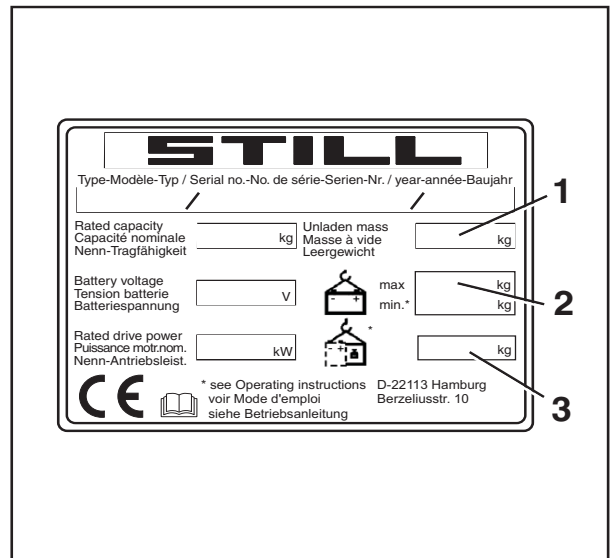



Attachments

Attachments

Fitting attachments

If the truck is equipped with an integrated attachment (variant) at the factory, the specifications in the STILL operating instructions for integrated attachments must be observed.

If attachments are fitted at the place of use, the specifications in the operating instructions of the attachment manufacturer must be observed.

If an attachment is not delivered together with the forklift truck, the specifications and operating instructions of the attachment manufacturer must be observed.

Before initial commissioning, the function of the attachment and the visibility from the driver's position with and without a load must be checked by a competent person. If the visibility is deemed insufficient, visual aids such as mirrors, a camera/monitor system etc. must be used.

In addition, it is essential that the warnings below are observed.

⚠ CAUTION

Attachments must be CE-certified. If the truck is not fitted with an attachment-specific residual load capacity rating plate, and the operating devices are not marked with the relevant pictograms, the truck must not be used.

- Order the residual load capacity rating plate and pictograms from your authorised service centre in good time.
- The authorised service centre must adapt the hydraulic system to the requirements of the attachment (e.g. by adjusting the pump motor speed).

⚠ DANGER

There is risk to life caused by a falling load!

Attachments that hold the load by exerting pressure on it (e.g. clamps) must be additionally controlled by a second operating function (lock) that is actuated to prevent an unintentional release of the load.

If such an attachment is retrofitted, a second operating function for actuation must also be retrofitted.

- Make sure that the additional clamp locking mechanism function is available.

⚠ DANGER

There is risk to life caused by a falling load!

During installation of a clamp with integral sideshift, ensure that the clamp does not open when the sideshift is actuated.

- Notify your authorised service centre before installation.
- Never grab or climb on moving parts of the truck.

Hydraulic connection

- Before fitting the attachment, release the pressure from the hydraulic system.

⚠ CAUTION

Risk of damage to components!

Open connections of plug connectors can become dirty. The plug connectors can become stiff and dirt can enter the hydraulic system.

- Once the attachments have been disassembled, attach the protective caps to the plug connectors.

Mounting attachments

Mounting an attachment and connecting the energy supply for an attachment must only be performed by competent persons in accordance with the information provided by the manufacturer and supplier of the attachment. After each installation, the attachment must be checked for correct function prior to initial commissioning.

i NOTE

Please note the definition of "competent person" in the sense of responsible persons!

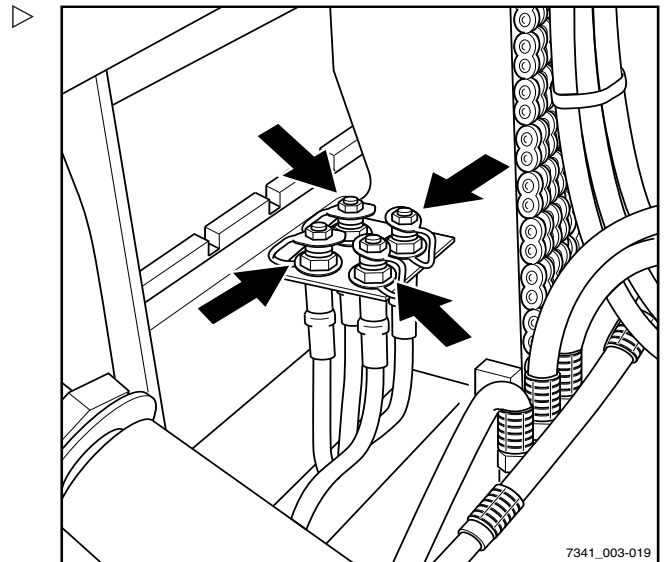

Attachments

Load capacity with attachment

The permissible load capacity of the attachment and the allowable load (load capacity and load moment) of the truck must not be exceeded by the combination of attachment and payload. The specifications of the manufacturer and supplier of the attachment must be complied with.

- Observe the residual load capacity rating plate, see the chapter entitled "Picking up a load using attachments".

Releasing the pressure from the hydraulic system

Prior to assembling attachments, the pressure must be released from the plug connectors (arrows).

Attachments must only be assembled by authorised personnel in accordance with the information provided by the manufacturer and supplier of the attachments. After each assembly, the attachment must be checked for proper functioning prior to being put into operation for the first time.

NOTE

The pressure release procedure is dependent on the operating devices for controlling the hydraulic functions; see the chapter entitled "Lifting system operating devices".

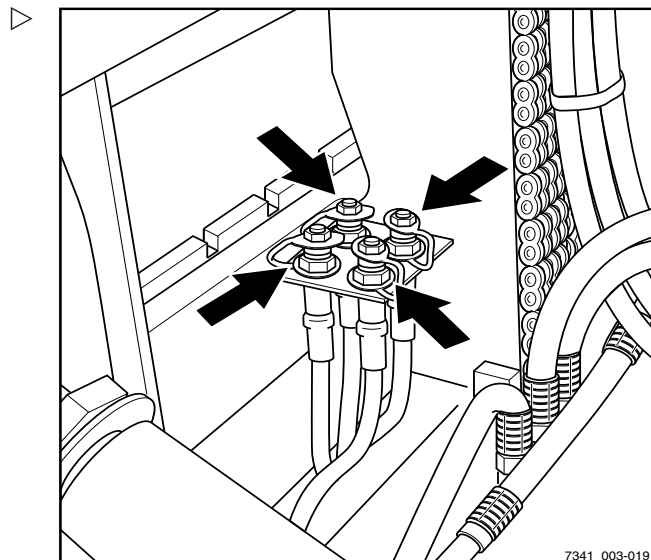

Releasing the pressure

NOTE

In trucks with the "FleetManager" or "access authorisation with PIN code" equipment variants, access authorisation must be enabled.

- Switch on the key switch.
- Lower the fork carriage.
- Switch on the hazard warning system (variant).

NOTE

Press the button for switching on the hazard warning system even if the truck is not equipped with a hazard warning system. Switching on the hazard warning system prevents the electrical system from being switched off, even if the key switch is subsequently switched off.

- Switch off the key switch.
- Actuate the operating lever (1) for controlling the hydraulic functions repeatedly in the direction of the arrow, as far as the end position.

The valves open and the hydraulic system is depressurised.

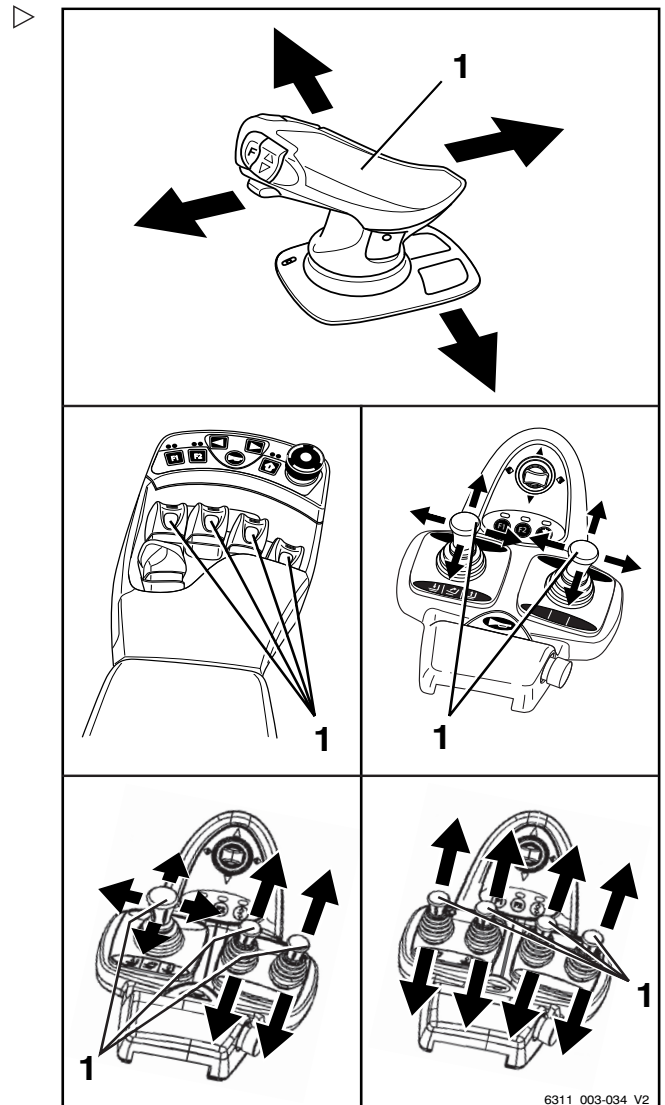

6311_003-034_V2

Attachments

General instructions for controlling attachments

The way in which attachments (variant) are controlled depends on the operating devices included in the truck's equipment.

Essentially, a distinction is drawn between:

- **Double mini-lever**
 - **Double mini-lever with a 5th function** (variant)
 - **Triple mini-lever**
 - **Triple mini-lever with a 5th function** (variant)
 - **Quadruple mini-lever**
 - **Quadruple mini-lever with a 5th function** (variant)
 - **Joystick 4Plus**
 - **Joystick 4Plus with a 5th function** (variant)
 - **Fingertip switch**
 - **Fingertip with a 5th function** (variant)
- For information on controlling attachments with the respective operating devices, see the relevant sections in this chapter.

WARNING

Use of attachments can give rise to additional hazards such as a change in the centre of gravity, additional danger areas etc.

Attachments must only be used for their intended purpose as described in the relevant operating instructions. Drivers must be taught how to operate the attachments.

Loads may only be picked up and transported with attachments if the loads are securely grasped and attached. Where necessary, loads must also be secured against slipping, rolling away, falling over, swinging or tipping over. Note that any change to the position of the load centre of gravity will affect the stability of the truck.

- Refer to the capacity rating plate for the attachments being used.

NOTE

Further variants and functions are available in addition to the functions described below. The directions of movement can be seen on the pictograms on the operating devices.

**i** NOTE

All the attachments described fall into the category of equipment variants. Please see the respective operating instructions for an exact description of the respective movements/actions of the attachment fitted.

Attachments

Controlling attachments using a double mini-lever

The attachments (variants) are controlled in this version using the "attachments" cross lever (1).

The pictograms on the "attachments" cross lever show the respective functions that are activated by this lever.

This essentially involves the following:

- Move the "attachments"(1) cross lever in the direction of the arrow (A) .

The attachment moves in accordance with the pictogram in position (A).

- Move the "attachments"(1) cross lever in the direction of the arrow (B) .

The attachment moves in accordance with the pictogram in position (B).

- Move the "attachments"(1) cross lever in the direction of the arrow (C) .

The attachment moves in accordance with the pictogram in position (C).

- Move the "attachments"(1) cross lever in the direction of the arrow (D) .

The attachment moves in accordance with the pictogram in position (D).

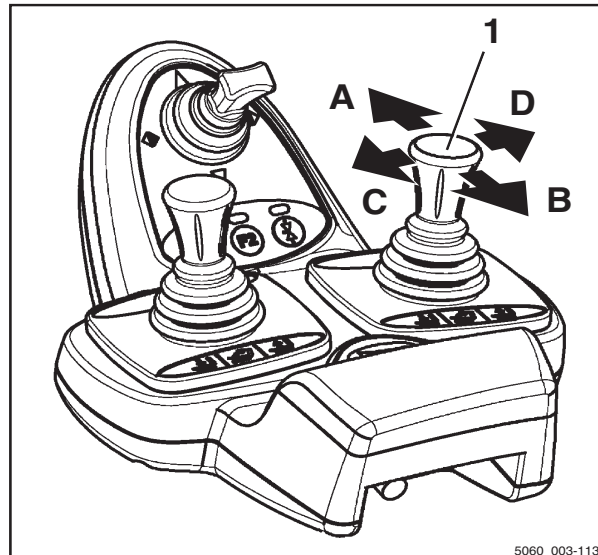

5060_003-113

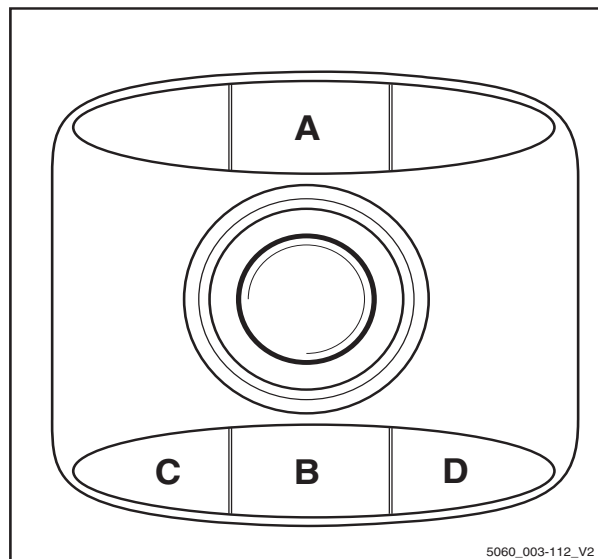

5060_003-112_V2

Operation

4

Attachments

– Note the following attachment functions and pictograms. ▷

3	Move sideshift frame or fork forwards
4	Move sideshift frame or fork backwards
5	Move sideshift to the left
6	Move sideshift to the right
7	Adjust fork arms: open
8	Adjust fork arms: close
9	Swivel lift mast or fork to the left
10	Swivel lift mast or fork to the right
11	Release load retainer
12	Clamp load retainer
13	Push off the load
14	Pull in the load
15	Open clamps
16	Close clamps
17	Rotate to the left
18	Rotate to the right
19	Tip shovel over
20	Tip shovel back

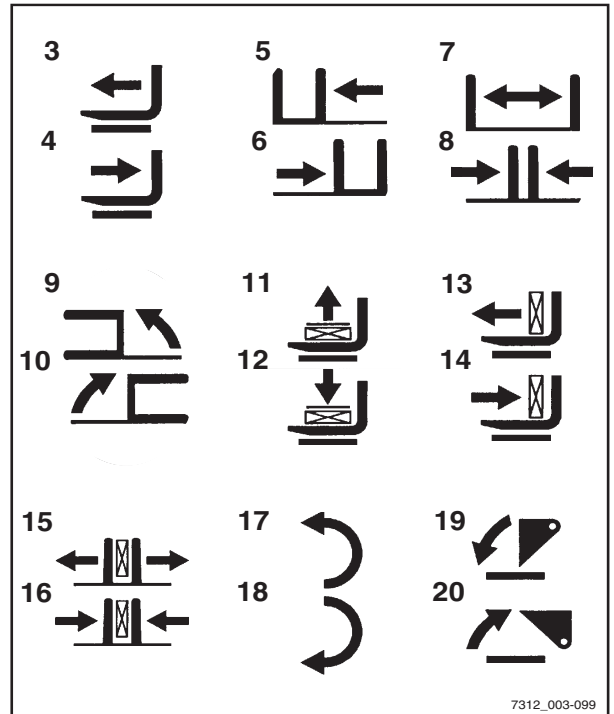

i NOTE

The pictograms shown correspond to the attachments fitted to this truck at the factory. If an attachment with other functions is fitted, the pictograms must be checked for the correct representation and changed if necessary.

– Contact the authorised service centre if required.

4

Operation

Attachments

Controlling attachments using the double mini-lever and the 5th function

i NOTE

For technical reasons, clamping attachments **must not** be controlled via the 5th function.

i NOTE

The "lift mast" 360° lever (3) and the "attachments" cross lever (2) control four hydraulic functions. The designation "5th function" refers to the fact that the 5th hydraulic function can be controlled with the cross lever by switching the functions using the "5th function" function key (1).

The pictograms on the "attachments" cross lever (2) show the respective functions that are activated by this lever.

This essentially involves the following:

- Actuate the "5th function" function key (1) and move the "attachments" cross lever (2) in the direction of arrow (E).

The attachment moves in accordance with the pictogram in position (E).

- Actuate the "5th function" function key (1) and move the "attachments" cross lever (2) in the direction of arrow (F).

The attachment moves in accordance with the pictogram in position (F).

i NOTE

The pictograms are attached depending on the pre-assembled attachment. If an attachment with other functions is fitted, the pictograms must be checked for the correct representation and changed if necessary.

- Contact the authorised service centre if required.

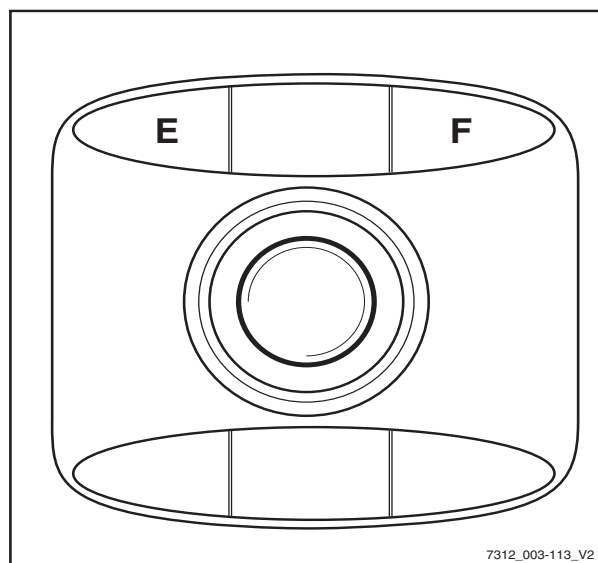
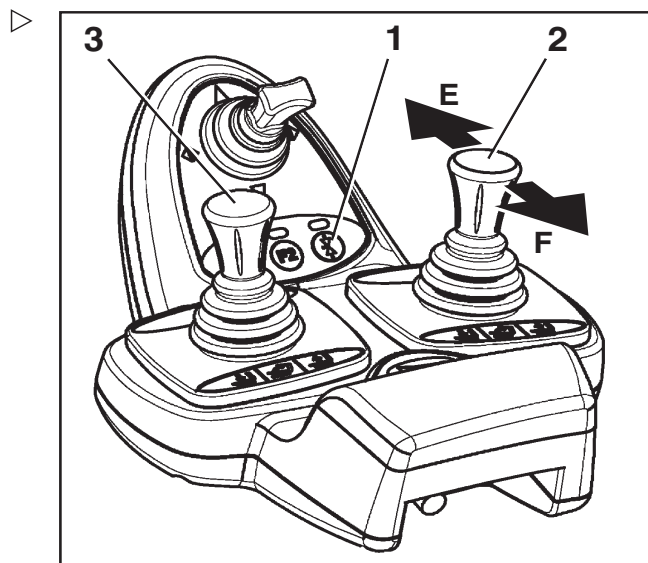

7312_003-113_V2

Operation

4

Attachments

– Note the following attachment functions and pictograms.

3	Move sideshift frame or fork forwards
4	Move sideshift frame or fork backwards
5	Move sideshift to the left
6	Move sideshift to the right
7	Adjust fork arms: open
8	Adjust fork arms: close
9	Swivel lift mast or fork to the left
10	Swivel lift mast or fork to the right
11	Release load retainer
12	Clamp load retainer
13	Push off the load
14	Pull in the load
15	Rotate to the left
16	Rotate to the right
17	Tip shovel over
18	Tip shovel back

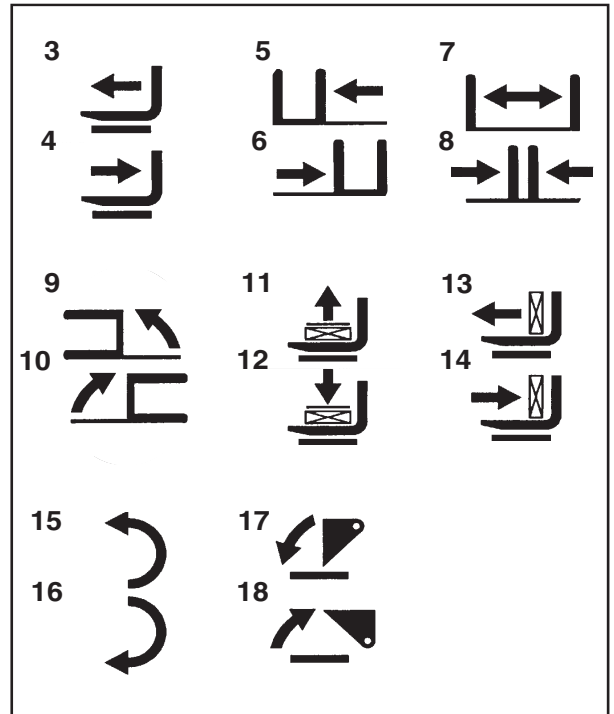

4 Operation

Attachments

Controlling attachments using a triple mini-lever

The attachments (variant) are controlled in this version using operating levers (1) and (2).

The pictograms on the operating levers show the respective functions that are activated by these levers.

This essentially involves the following:

- Move the operating lever (1) towards (A)
The attachment moves in accordance with the pictogram in position (A).
- Move the operating lever (1) towards (B)
The attachment moves in accordance with the pictogram in position (B).
- Move the operating lever (2) towards (C)
The attachment moves in accordance with the pictogram in position (C).
- Move the operating lever (2) towards (D)
The attachment moves in accordance with the pictogram in position (D).

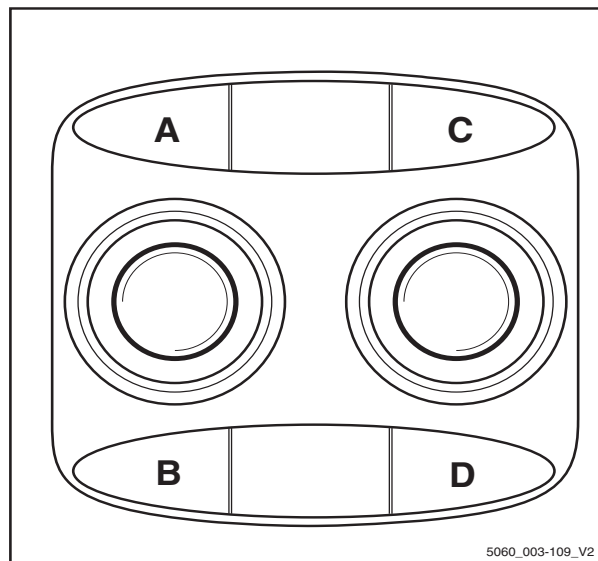
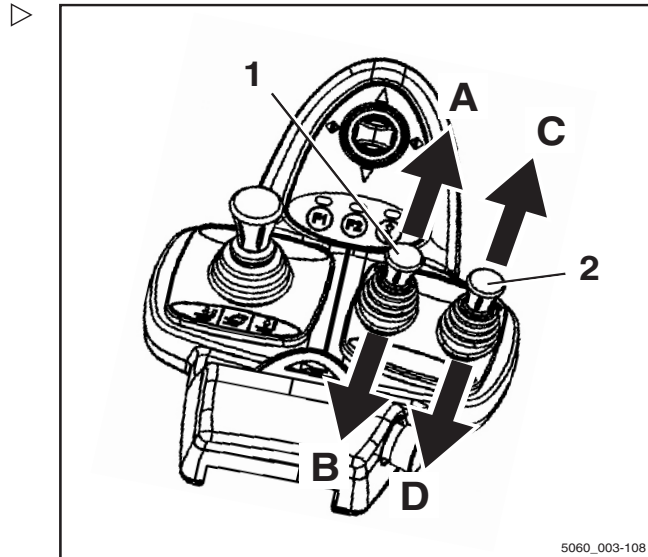

Operation

4

Attachments

– Note the following attachment functions and pictograms.

3	Move sideshift frame or fork forwards
4	Move sideshift frame or fork backwards
5	Move sideshift to the left
6	Move sideshift to the right
7	Adjust fork arms: open
8	Adjust fork arms: close
9	Swivel lift mast or fork to the left
10	Swivel lift mast or fork to the right
11	Release load retainer
12	Clamp load retainer
13	Push off the load
14	Pull in the load
15	Open clamps
16	Close clamps
17	Rotate to the left
18	Rotate to the right
19	Tip shovel over
20	Tip shovel back

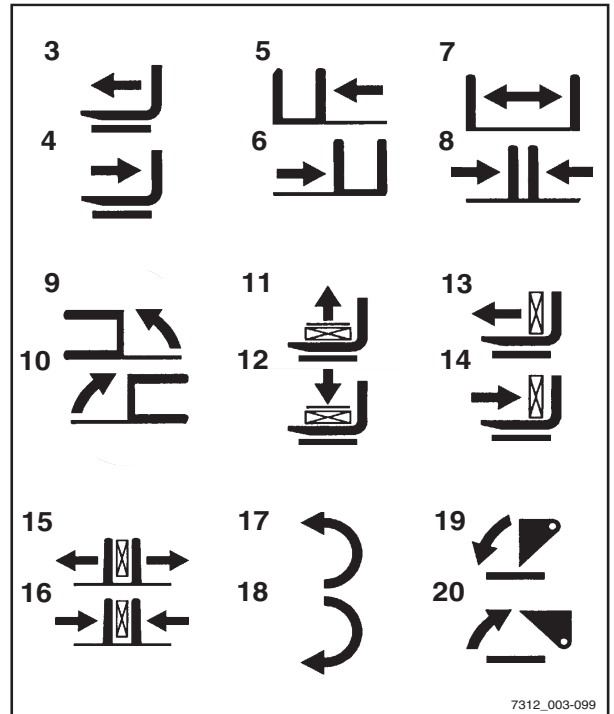

i NOTE

The pictograms shown correspond to the attachments fitted to this truck at the factory. If an attachment with other functions is fitted, the pictograms must be checked for the correct representation and changed if necessary.

– Contact the authorised service centre if required.

4 Operation

Attachments

Controlling attachments using the triple mini-lever and the 5th function

i NOTE

For technical reasons, clamping attachments **must not** be controlled via the 5th function.

i NOTE

The "lift mast" 360° lever and operating levers (1) and (2) control four hydraulic functions. The designation "5th function" refers to the fact that the 5th hydraulic function can be controlled with the operating lever (1) by switching the functions using the function key (3).

The pictograms on the operating levers show the respective functions that are activated by these levers.

This essentially involves the following:

- Actuate the "5th function" function key (3) and move operating lever (1) towards (E).

The attachment moves in accordance with the pictogram in position (E).

- Actuate the "5th function" function key (3) and move operating lever (1) towards (F).

The attachment moves in accordance with the pictogram in position (F).

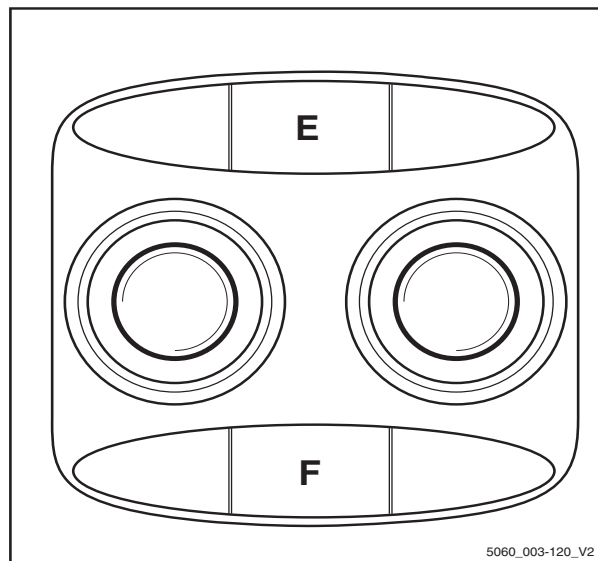
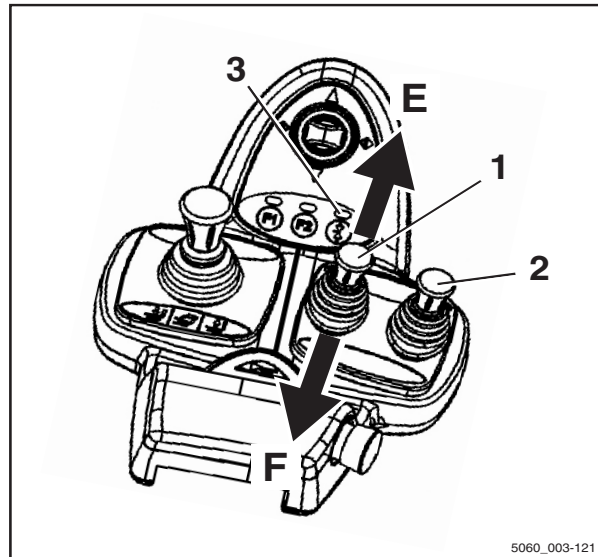

Operation

4

Attachments

- Note the following attachment functions and pictograms. ▷

1	Adjust fork arms: open
2	Adjust fork arms: close
3	Rotate to the left
4	Rotate to the right

i NOTE

The pictograms shown correspond to the attachments fitted to this truck at the factory. If an attachment with other functions is fitted, the pictograms must be checked for the correct representation and changed if necessary.

- Contact the authorised service centre if required.

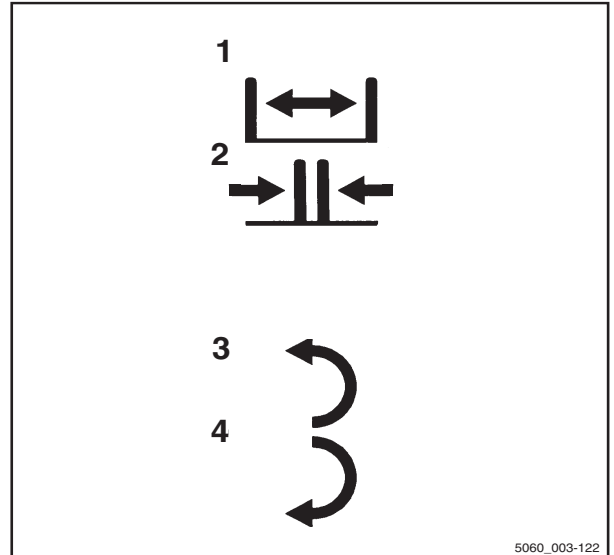

4 Operation

Attachments

Controlling attachments using a quadruple mini-lever

The attachments (variant) are controlled in this version using operating levers (1) and (2).

The pictograms on the operating levers show the respective function that is activated by these levers.

This essentially involves the following:

- Move the operating lever (1) towards (A)
The attachment moves in the direction shown in pictogram (A).
- Move the operating lever (1) towards (B)
The attachment moves in the direction shown in pictogram (B).
- Move the operating lever (2) towards (C)
The attachment moves in the direction shown in pictogram (C).
- Move the operating lever (2) towards (D)
The attachment moves in the direction shown in pictogram (D).

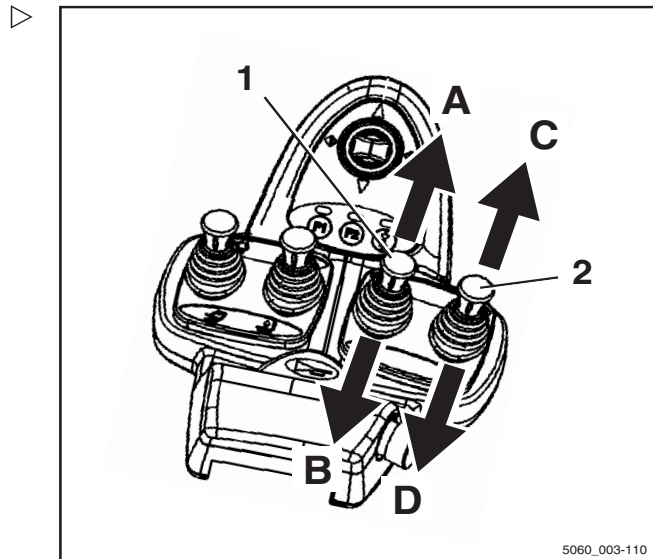

5060_003-110

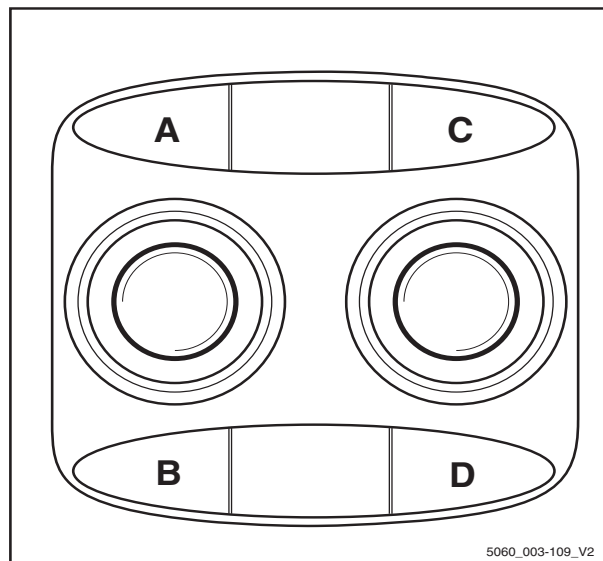

5060_003-109_V2

Operation

4

Attachments

– Note the following attachment functions and pictograms.

3	Move sideshift frame or fork forwards
4	Move sideshift frame or fork backwards
5	Move sideshift to the left
6	Move sideshift to the right
7	Adjust fork arms: open
8	Adjust fork arms: close
9	Swivel lift mast or fork to the left
10	Swivel lift mast or fork to the right
11	Release load retainer
12	Clamp load retainer
13	Push off the load
14	Pull in the load
15	Open clamps
16	Close clamps
17	Rotate to the left
18	Rotate to the right
19	Tip shovel over
20	Tip shovel back

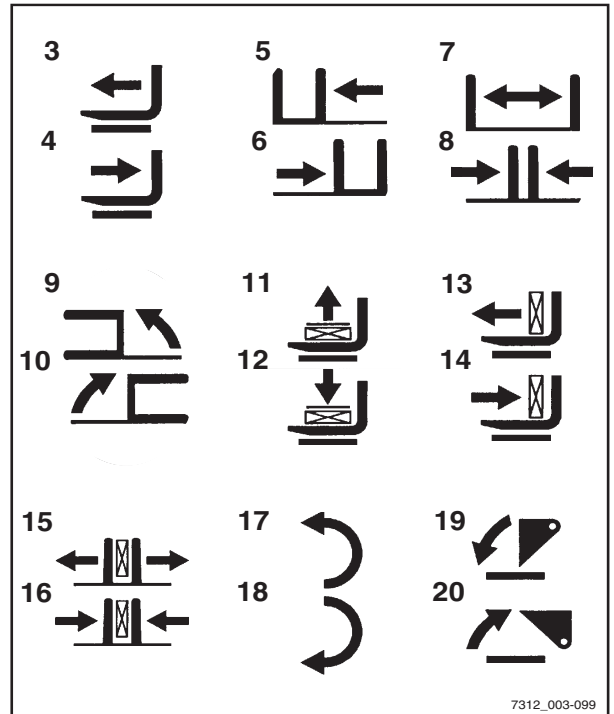

7312_003-099

i NOTE

The pictograms shown correspond to the attachments fitted to this truck at the factory. If an attachment with other functions is fitted, the pictograms must be checked for the correct representation and changed if necessary.

– Contact the authorised service centre if required.

4 Attachments Operation

Controlling attachments using the quadruple mini-lever and the 5th function

i NOTE

For technical reasons, clamping attachments **must not** be controlled via the 5th function.

i NOTE

Operating levers (1) to (4) are used to control four hydraulic functions. The designation "5th function" refers to the fact that the 5th hydraulic function can be controlled with the operating lever (3) by switching the functions using the "5th function" function key (5).

The pictograms on the operating levers show the respective functions that are activated by these levers.

This essentially involves the following:

- Actuate the "5th function" function key (5) and move operating lever (3) towards (E).

The attachment moves in accordance with the pictogram in position (E).

- Actuate the "5th function" function key (5) and move operating lever (3) towards (F).

The attachment moves in accordance with the pictogram in position (F).

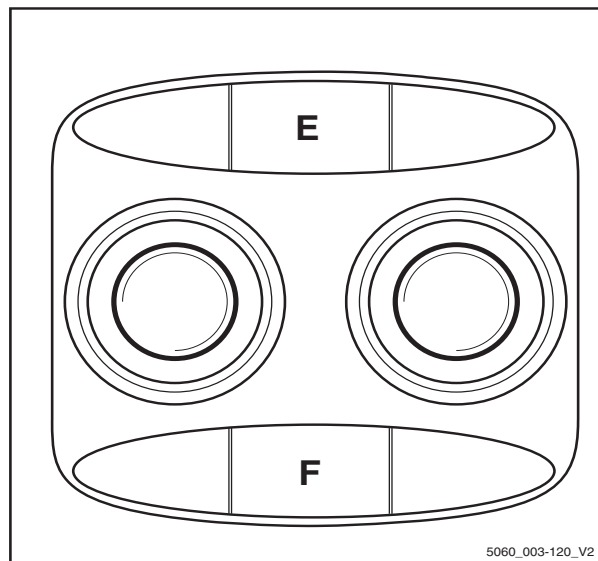
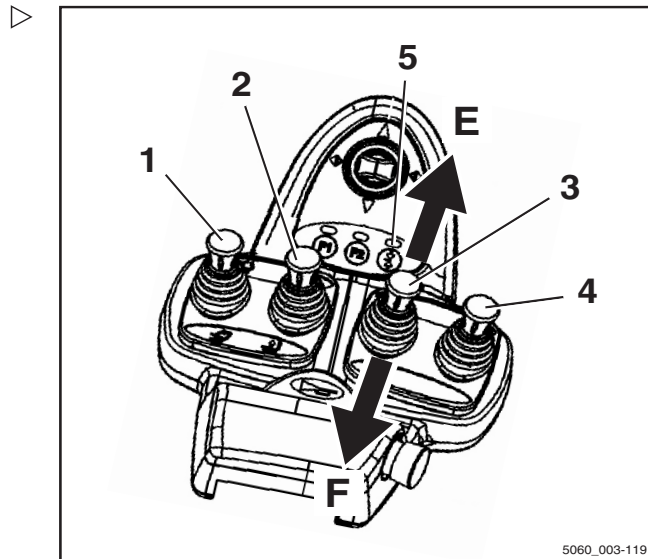

Operation

4

Attachments

- Note the following attachment functions and pictograms. ▷

1	Adjust fork arms: open
2	Adjust fork arms: close
3	Rotate to the left
4	Rotate to the right

i NOTE

The pictograms shown correspond to the attachments fitted to this truck at the factory. If an attachment with other functions is fitted, the pictograms must be checked for the correct representation and changed if necessary.

- Contact the authorised service centre if required.

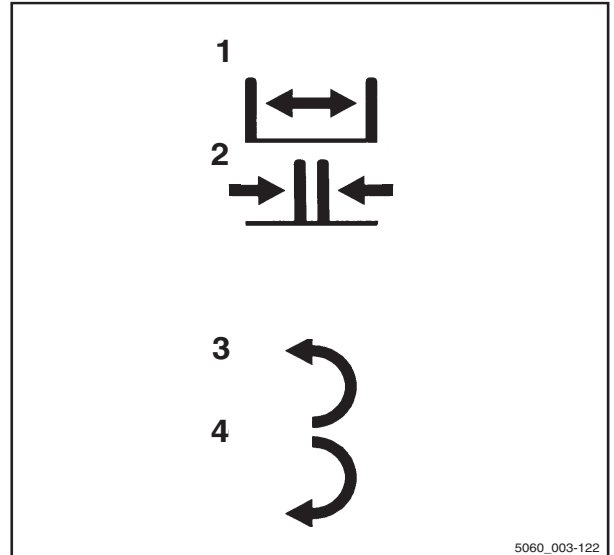

4 Operation

Attachments

Controlling attachments via the joystick 4Plus

In this equipment, the attachments (variant) are controlled via the joystick 4Plus (1).

The pictograms on the decal information about operation of the joystick 4Plus show the respective functions that are activated by the individual operating devices of the joystick 4Plus.

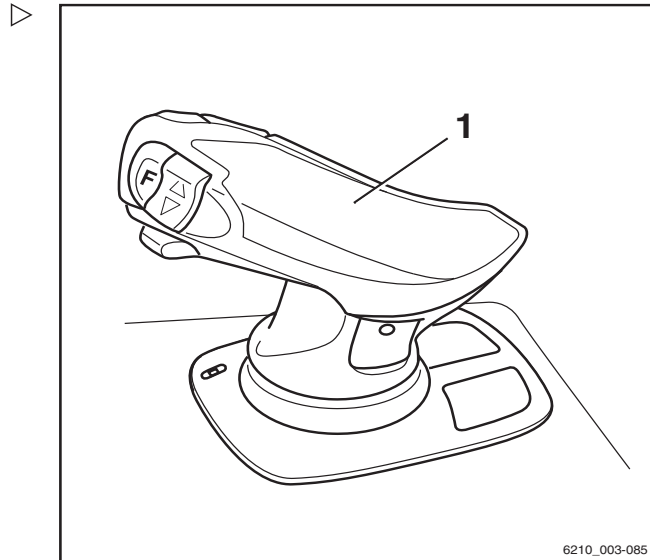

– Note the following attachment functions and pictograms.

	Operating device	Function of the attachment
1	Joystick 4Plus	Move sideshift to the left/right
2	Joystick 4Plus or slider	Adjust fork arms: open/close
3	Slider	Move reach frame or fork carriage forwards/backwards
4	Joystick 4Plus or slider	Rotate attachment left/right
5	Slider	Tip shovel over/tip shovel back

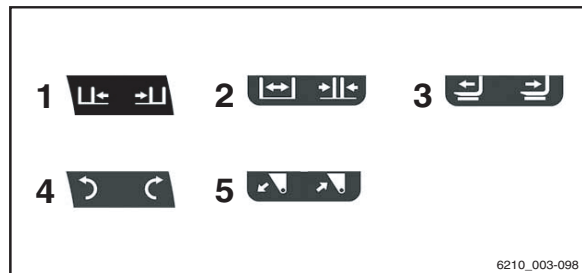

NOTE

The pictograms on the joystick 4Plus are attached according to the attachments fitted to this truck at the factory. If an attachment with other functions is fitted, the pictograms must be checked for the correct representation and changed if necessary.

– Contact the authorised service centre if required.

Controlling attachments using the joystick 4Plus and the 5th function

NOTE

*For technical reasons, clamping attachments **cannot** be controlled via the 5th function.*

NOTE

The 5th hydraulic function can be used to control an attachment. The pictograms on the joystick 4Plus show which attachment functions can be controlled using the 5th function.

For attachments that are controlled using the 5th hydraulic function, the procedures for operation are as follows:

- Press and hold shift key "F"(1) on the joystick 4Plus.
- Simultaneously actuate the horizontal rocker button (2) in the direction shown in the pictogram.

The attachment moves in the selected direction.

NOTE

The pictograms are attached depending on the pre-assembled attachment. If an attachment with other functions is fitted, the pictograms must be checked for the correct representation and changed if necessary.

- Contact the authorised service centre if required.

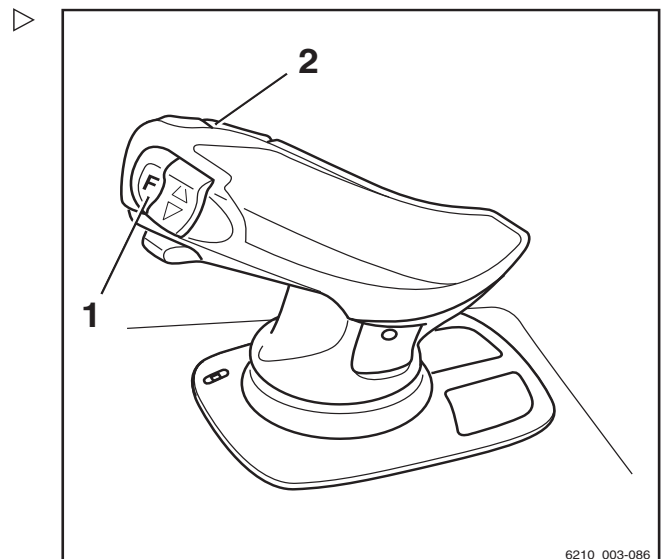

6210_003-086

4 Operation

Attachments

Controlling the attachments with fingertip

The attachments (variant) are controlled in this version using the operating levers (1).

The pictograms on the operating levers always show the functions that are activated by that lever.

- Move operating lever (1) forwards.

The attachment moves in the direction of movement shown in the upper part of the pictogram.

- Move operating lever (1) backwards.

The attachment moves in the direction of movement shown in the lower part of the pictogram.

- Note the following attachment functions and pictograms.

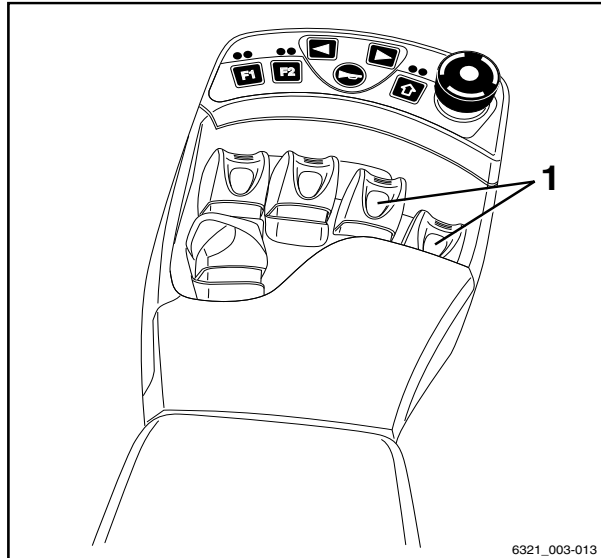

6321_003-013

2	Move side shift frame or forks forwards/backwards
3	Move sideshift to the left/to the right
4	Adjust fork arms: open/close
5	Swivel lift mast or forks to the left/to the right
6	Release/clamp load retainer
7	Push off/pull in load
8	Open/close clamps
9	Turn to the left/to the right
10	Tip shovel over/tip shovel back

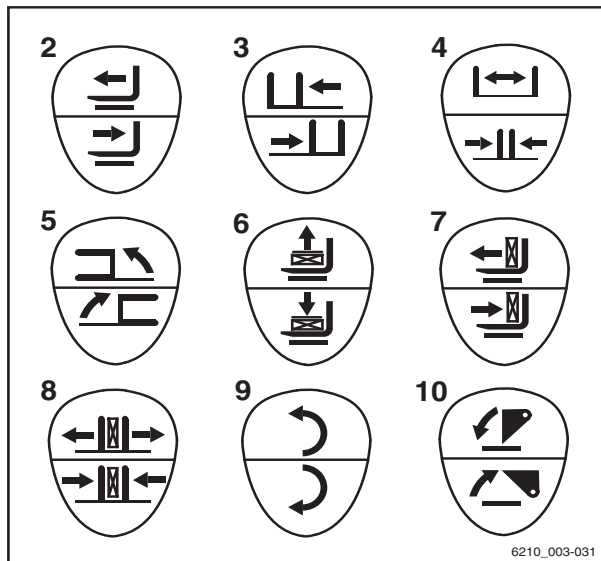

6210_003-031

i NOTE

The pictograms shown correspond to the attachments fitted to this truck at the factory. If an attachment with other functions is fitted, the pictograms must be checked for the correct representation and changed if necessary.

- Contact the authorised service centre if required.

Controlling attachments with fingertip and the 5th function

i NOTE

For technical reasons, clamping attachments **must not** be controlled via the 5th function.

i NOTE

The designation "5th function" refers to the fact that the four operating levers control four functions, while the "5th function" can be controlled by switching functions.

The attachments (variant) are controlled using the operating levers (1).

You can also use the switch (2) to switch functions, in which case the corresponding operating lever controls the "5th function".

The pictogram (3) behind the operating lever shows in the upper and lower parts the function that is activated with this lever.

The meanings are as follows:

- Move operating lever forwards.

The attachment moves in the direction of movement shown in the upper part of the pictogram.

- Move operating lever back.

The attachment moves in the direction of movement shown in the lower part of the pictogram.

- Actuate the switch (2).

The additional function of the attachment is activated/deactivated and can be controlled as the "5th function" using the operating lever.

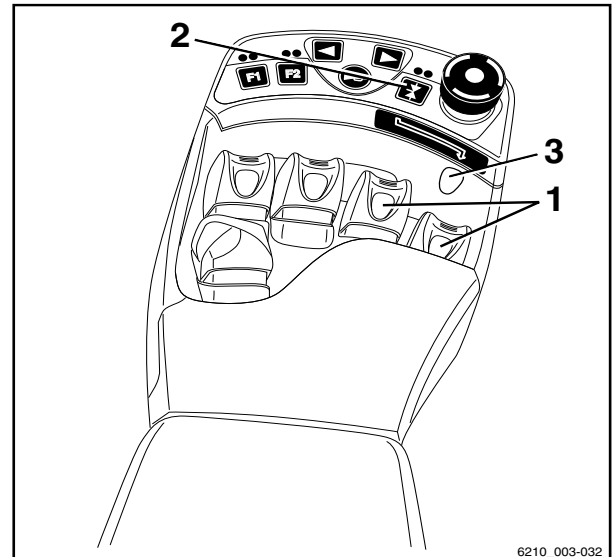

6210_003-032

4 Operation

Attachments

- Press the function key (4).

i NOTE

The arrow (5) under the function key indicates which operating lever is equipped with the "5th function".

The "5th function" is switched to the 3rd operating lever; see adhesive label (6).

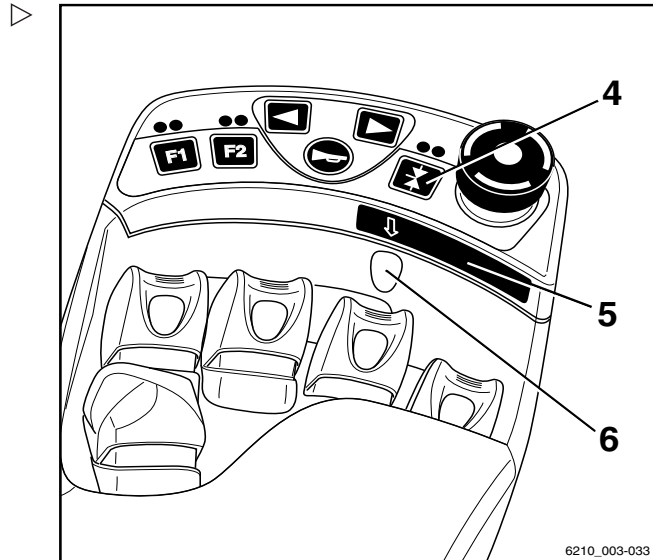

- Press the function key (7).

i NOTE

The arrow (8) under the function key indicates which operating lever is equipped with the "5th function".

The "5th function" is switched to the 4th operating lever; see adhesive label (9).

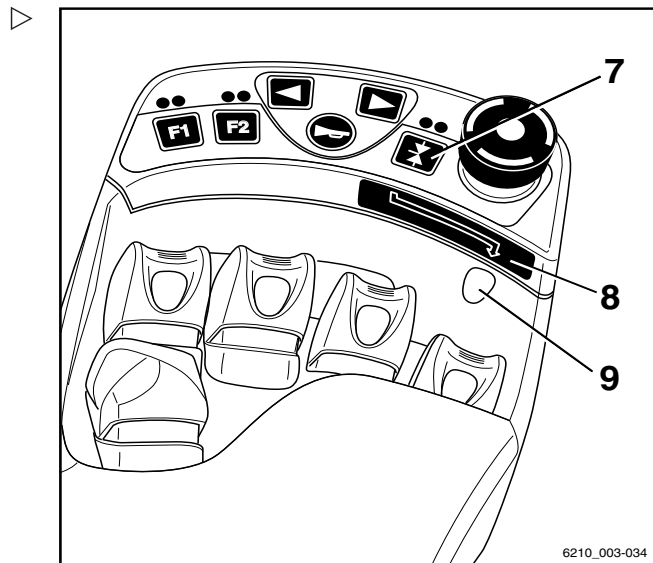

i NOTE

The movement/action of this "5th function" can be found in the operating instructions of the fitted attachment.

i NOTE

The pictograms are applied depending on the pre-assembled attachment. If an attachment with other functions is fitted, the pictograms must be checked for the correct representation and changed if necessary.

- Contact the authorised service centre if required.

- Note the following attachment functions and pictograms.

10	Move side shift frame or fork forwards/backwards
11	Move sideshift to the left/right
12	Adjust fork arms: open/close
13	Swivel lift mast or fork to the left/right
14	Release/clamp load retainer
15	Push off/pull in load
16	Turn to the left/right
17	Tip shovel over/tip shovel back

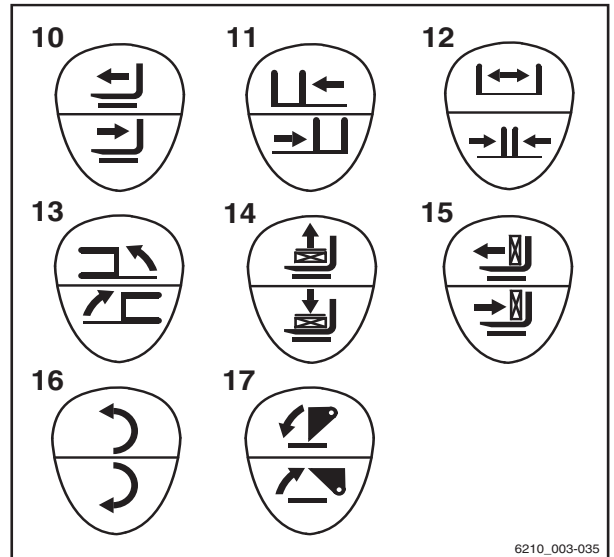

6210_003-035

Clamp locking mechanism (variant)

This truck can be fitted with a clamp locking mechanism as a variant. This prevents the clamp from opening unintentionally if the operating function is inadvertently triggered.

⚠ DANGER

There is a risk of fatal injury from falling loads if the correct function of the clamp locking mechanism is not guaranteed!

If other attachments are used on this truck in addition to the clamp, make sure that the clamp locking mechanism function is reassigned to the corresponding operating device every time the clamp is reassembled; see the chapter entitled "Fitting attachments".

- Make sure that the additional clamp locking mechanism function is available.

4

Operation

Attachments

Double mini-lever

- To release the clamp locking mechanism, push the cross lever (1) forwards.

The LED for button **F2** (2) lights up as long as the clamp locking mechanism is released.

i NOTE

The hydraulic function for opening the clamp is available for one second after the clamp locking mechanism is released. After one second, the clamp locking mechanism is automatically reactivated.

- To open the clamp, push the cross lever (1) forwards again.

It is not necessary to release the clamp locking mechanism in order to close the clamp.

- To close the clamp, pull the cross lever (1) back.

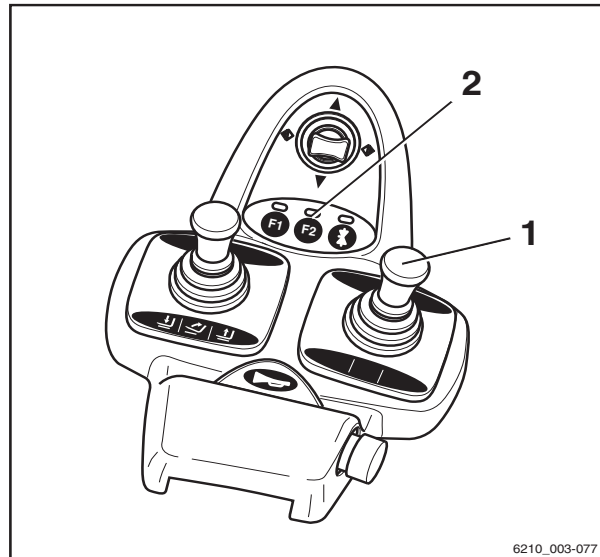

Triple mini-lever

- To release the clamp locking mechanism, push the operating lever (1) forwards.

The LED for button **F2** (2) lights up as long as the clamp locking mechanism is released.

i NOTE

The hydraulic function for opening the clamp is available for one second after the clamp locking mechanism is released. After one second, the clamp locking mechanism is automatically reactivated.

- To open the clamp, push the operating lever (1) forwards again.

It is not necessary to release the clamp locking mechanism in order to close the clamp.

- To close the clamp, pull the operating lever (1) back.

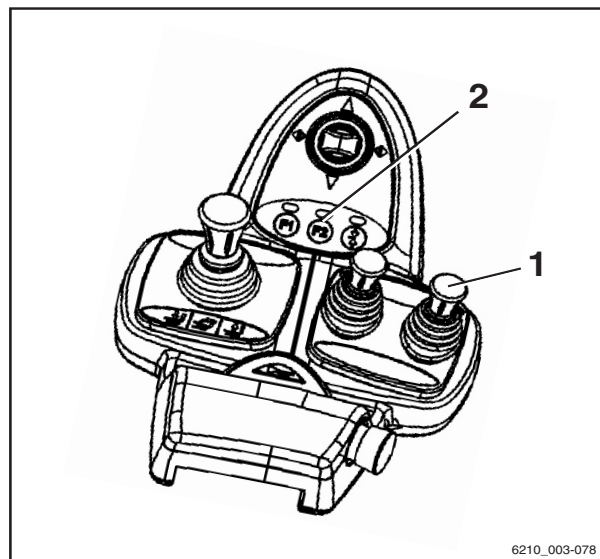

Quadruple mini-lever

- To release the clamp locking mechanism, push the operating lever (1) forwards.

The LED for button **F2** (2) lights up as long as the clamp locking mechanism is released.

NOTE

The hydraulic function for opening the clamp is available for one second after the clamp locking mechanism is released. After one second, the clamp locking mechanism is automatically reactivated.

- To open the clamp, push the operating lever (1) forwards again.

It is not necessary to release the clamp locking mechanism in order to close the clamp.

- To close the clamp, pull the operating lever (1) back.

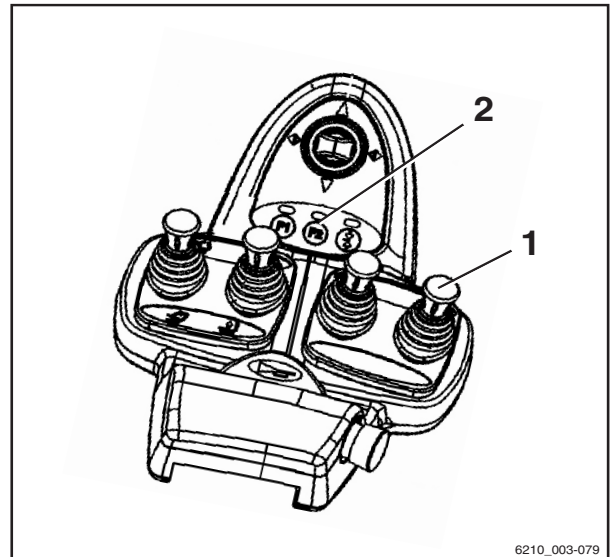

Joystick 4Plus

- To release the clamp locking mechanism, press and hold shift key **F** (3) and move the horizontal rocker button (1) to the right.
- Keep shift key **F** (3) pressed and move the horizontal rocker button (1) back to the neutral position.

The LED (2) lights up as long as the clamp locking mechanism is released.

- To open the clamp, press and hold shift key **F** (3) and move the horizontal rocker button (1) to the right.

NOTE

The hydraulic function for opening the clamp is available for one second after the clamp locking mechanism is released. After one second, the clamp locking mechanism is automatically reactivated.

It is not necessary to release the clamp locking mechanism in order to close the clamp.

- To close the clamp, press and hold shift key **F** (3) and move the horizontal rocker button (1) to the left.

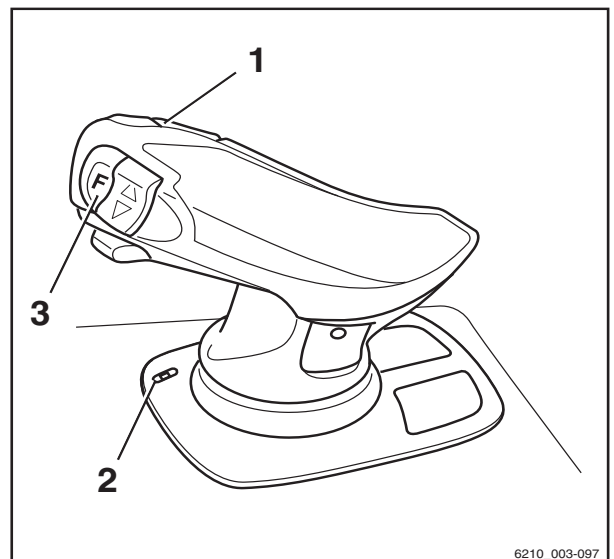

4 Attachments Operation

Fingertip

- To release the clamp locking mechanism, push the operating lever (1) forwards.

The LED for button **F2** (2) lights up as long as the clamp locking mechanism is released.

i NOTE

The hydraulic function for opening the clamp is available for one second after the clamp locking mechanism is released. After one second, the clamp locking mechanism is automatically reactivated.

- To open the clamp, push the operating lever (1) forwards again.

It is not necessary to release the clamp locking mechanism in order to close the clamp.

- To close the clamp, pull the operating lever (1) back.

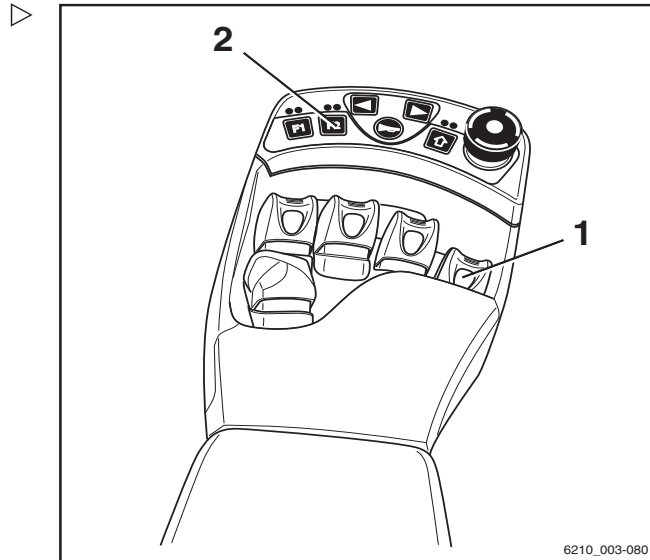

Taking up a load using attachments

⚠ WARNING

Risk of accidents!

Attachments may only be used for their intended purpose as described in the relevant operating instructions.

Drivers must be instructed in the handling of the attachments.

⚠ WARNING

Risk of accidents!

Loads may only be picked up and transported with attachments if they are securely attached. Where necessary, loads should also be secured against slipping, rolling, falling over, swinging or tipping over. Note that any change to the position of the load's centre of gravity will affect the stability of the forklift truck.

Check the capacity rating plates for the attachments or combination of attachments.

- The rating plates show the permissible values for:

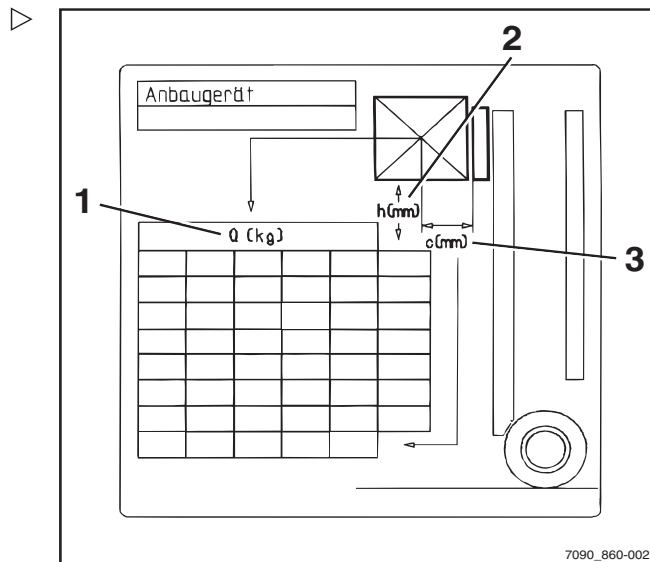

- Load capacity Q (kg) (1)
- Lift height h (mm) (2)
- Load distance C (mm) (3)

Auxiliary equipment

Switching the lighting on and off

Driving lights

- To switch on the parking light, press the button (1). ▷

The front sidelights and the rear lights light up. On the variant with StVZO (German Road Traffic Licensing Regulations) equipment, the licence plate lamp also lights up.

- To switch on the headlights, press the button (1) again.

The headlights light up in addition to the parking light.

- To switch off the driving lights, press the button (1) again.

The driving lights go out.

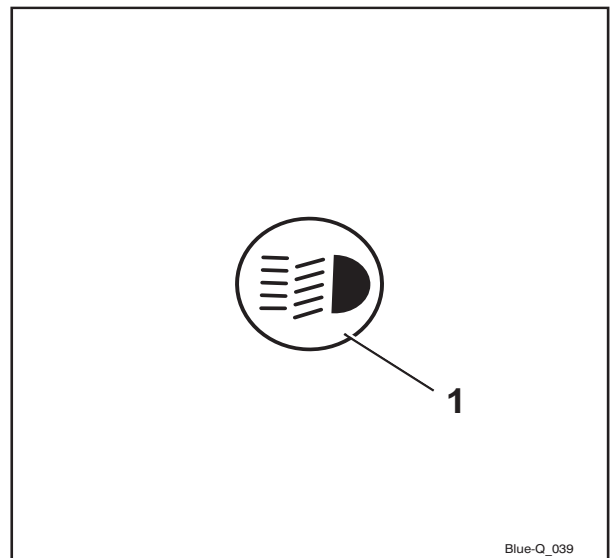

Blue-Q_039

4

Operation

Auxiliary equipment

Working spotlights

- To switch on the working spotlights (front and rear), press the button (1).

The working spotlights light up.

- To switch off the working spotlights, press the button (1) again.

The working spotlights go out.

i NOTE

In trucks with StVZO (German Road Traffic Licensing Regulations) equipment (variant), the following lighting elements on the truck are also activated when the working spotlights are switched on:

- Rear lights
- Licence plate lamp
- Sidelights

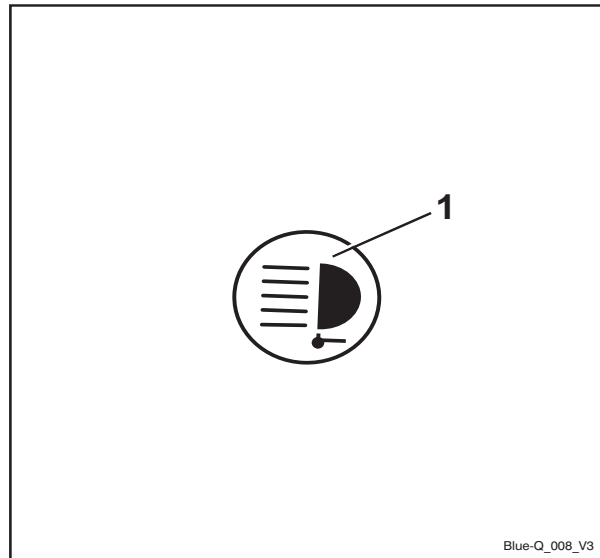

Blue-Q_008_V3

Switching the working spotlight for reverse travel on and off

The working spotlight for reverse travel is attached to the overhead guard at the rear. It provides optimal illumination of the roadway if the truck is travelling in reverse.

- Press the softkey (1).

The symbol (2) is displayed. The rear working spotlight does not yet illuminate.

- Set the drive direction to "Reverse".

The rear working spotlight illuminates.

i NOTE

If the drive direction is set to "Forwards", the rear working spotlight goes out.

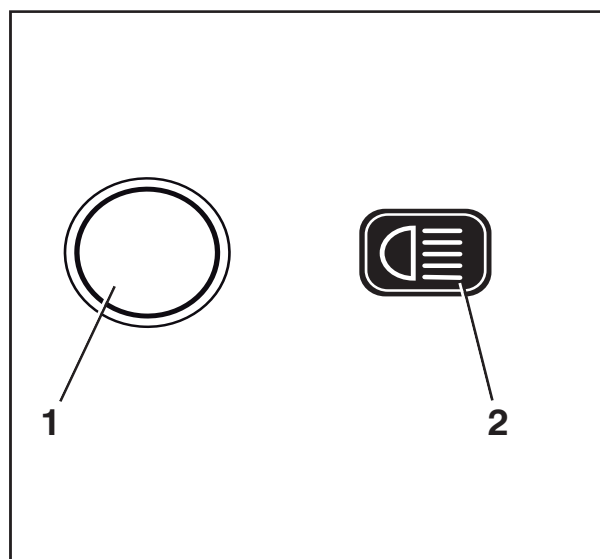

Switching the rotating beacon on and off

- Press the Softkey  (1) to switch on the rotating beacon.

The rotating beacon is switched on. The symbol  is displayed.

- To switch off the rotating beacon, press the Softkey .

The rotating beacon goes out. The symbol  (2) is displayed.

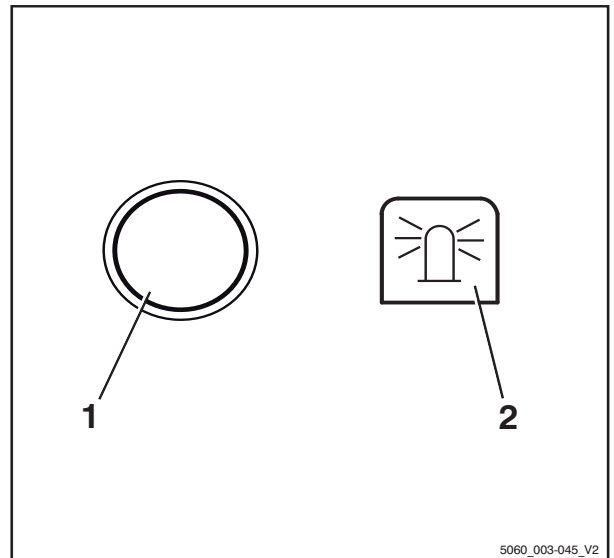

Switching the hazard warning system on and off

- To switch on the hazard warning system, press the button (1).

All turn indicators and indicator lights (2) flash.

- To switch off the hazard warning system, press the button (1) again.

The hazard warning system goes out.

NOTE

To switch on the hazard warning system without the key switch being switched on, press and hold the button for three seconds.

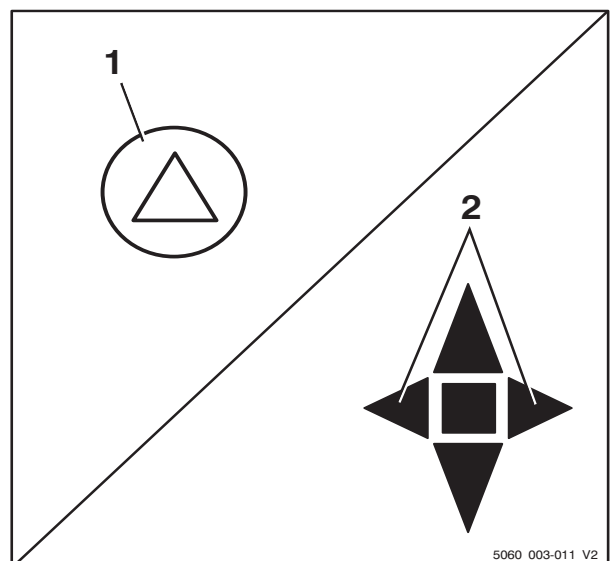

4 Operation

Auxiliary equipment

Switching the turn indicators on and off

Mini-lever version

- Switch on the turn indicators by moving the cross lever of the drive direction/turn indicator (1) to the left or to the right.

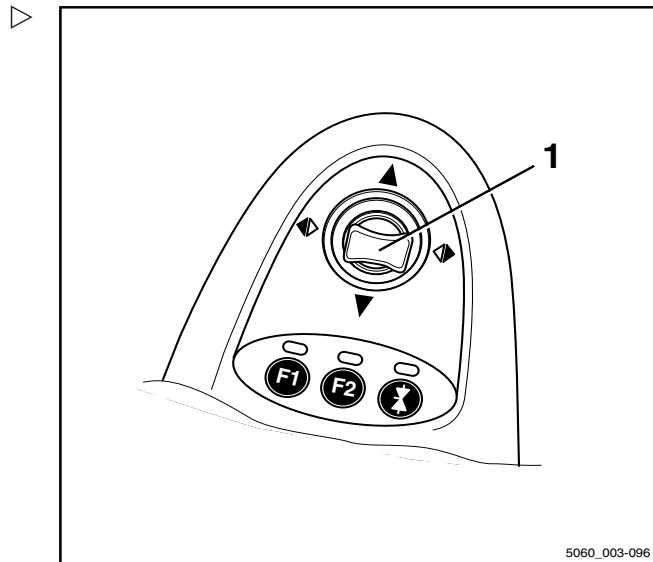

The turn indicators and the corresponding turn indicator displays (2) or (3) flash.

- Switch off the turn indicators by moving the cross lever to the centre position.

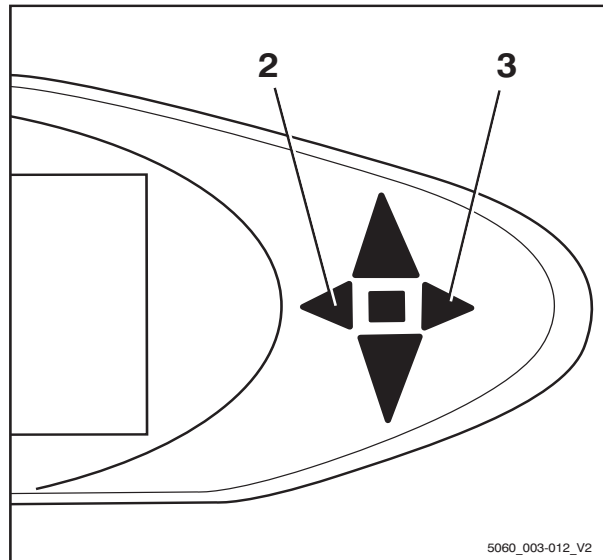

Mini-console version

- Switch on the turn indicators by moving the turn indicator switch (1) to the left or to the right.

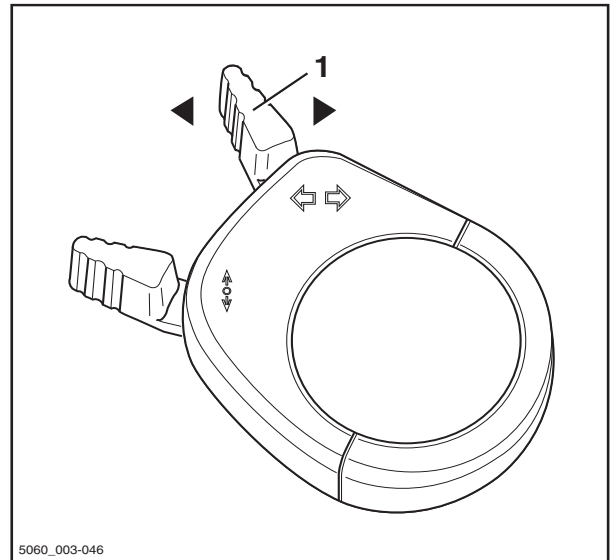

5060_003-046

The turn indicators and the corresponding turn indicator displays (2) or (3) flash. ▷

- Switch off the turn indicators by moving the turn indicator switch to the centre position.

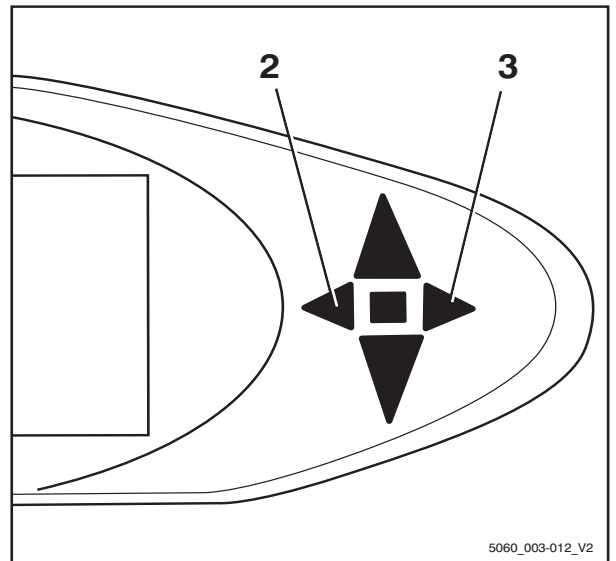

5060_003-012_V2

Auxiliary equipment

Switching the double working spotlights on and off.

The double working spotlights are fitted up on the front right and left on the overhead guard. Each double working spotlight consists of an upper working spotlight (2) and a lower working spotlight (3). The upper working spotlight illuminates the working area at great lift heights, the lower working spotlight illuminates the working area directly in front of the truck.

Depending on the equipment, the upper working spotlights can be switched on/off automatically or manually.

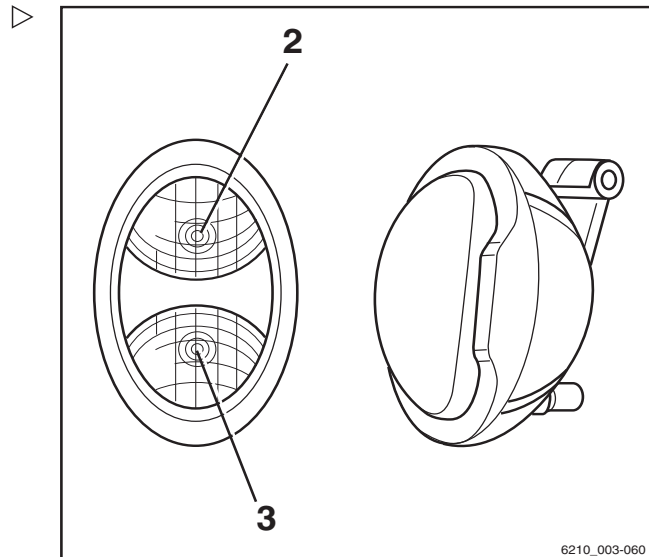

Switching the upper working spotlights on/off manually

i NOTE

The upper working spotlights can be switched on/off independently of the lower working spotlights. For information about switching on the lower working spotlights, see the section entitled "Switching the lighting on and off".

i NOTE

This function is not available if the truck is equipped with rear window heating.

- Turn the key switch to position "I".

- Press Softkey  (1) to switch on the working spotlights.

The working spotlights are switched on. The  symbol is displayed.

- Press Softkey  to switch off the working spotlights.

The working spotlights are switched off. The  symbol is displayed.

Switching the upper working spotlights on/off automatically

- Turn the key switch to position "I".
- For information about switching on the working spotlights, see the chapter entitled "Switching the lighting on and off".

The lower working spotlights light up.

The upper working spotlights are switched on automatically when the lift mast is lifted for a period of at least two seconds.

NOTE

During these two seconds, a maximum of two lifts can be executed to prevent the working spotlights from switching on each time a precise adjustment is made. If more lifts are carried out during this time, the upper working spotlights will remain switched off.

NOTE

The upper working spotlights are switched off automatically when the truck is driven for longer than one second at a speed faster than 2.1 km/h.

Lift-height-controlled switching on/off of the upper working spotlights

NOTE

This equipment is available only if a proximity switch is fitted to the lift mast to record a particular lift height of the fork carriage on the lift mast.

- Turn the key switch to position "I".

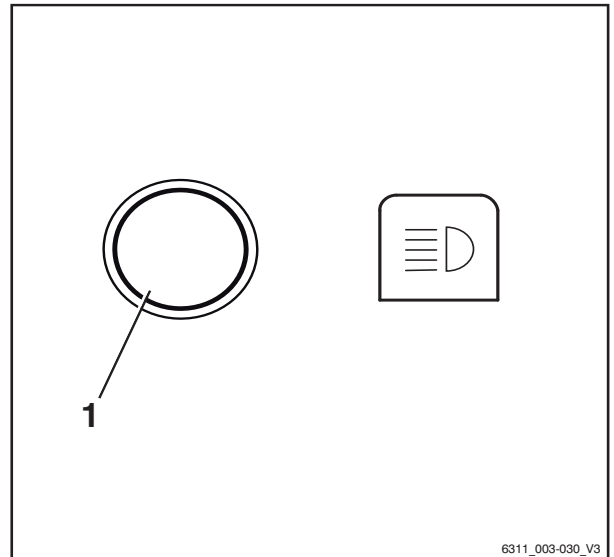

4 Operation

Auxiliary equipment

- Switch on the working spotlights.

The lower working spotlights light up.

The upper working spotlights are switched on by the proximity switch when the fork carriage reaches or exceeds the preset lift height.

The upper working spotlights are switched off by the proximity switch when the fork carriage falls below the preset lift height again.

⚠ CAUTION

Possible component damage caused by collision if the proximity switch is set incorrectly.

- The proximity switch may be adjusted by trained personnel.
- If necessary, inform the authorised service centre.

STILL SafetyLight (variant)



⚠ WARNING

Danger of damage to eyes from looking into the STILL SafetyLight.
Do not look into the STILL SafetyLight.

The STILL SafetyLight is a visual warning unit designed to enable early detection of trucks in driving areas with low visibility (such as drive lanes, high racks), as well as at blind junctions. The STILL SafetyLight is mounted on a support on the overhead guard such that it is not affected by jolts and vibrations. The STILL SafetyLight projects one or more light-blue light spots in front of or behind the truck and thus warns others about the approaching truck. Several light spots are projected as a chase light. The chase light indicates the location of the truck with its direction of travel.

Depending on the configuration of the truck, the STILL SafetyLight automatically switches itself on when the truck is moving. The STILL SafetyLight can also be switched on and off on the display-operating unit.

- To do so, press the corresponding button.

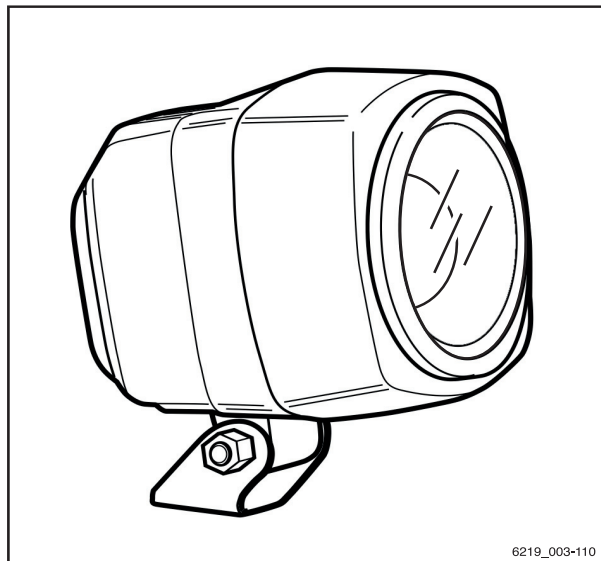

6219_003-110

i NOTE

If the truck is to be operated on public roads, the STILL SafetyLight must be switched off.

Operating the windscreen wiper/washer

- Press the button (1) to activate the front wiper/washer (variant) and the roof panel wiper (variant).
- Push button (2) to actuate the rear windscreen wiper/washer (variant).

Repeated pressing of the respective button switches between the operating stages in the sequence shown below.

Button actuation	Operating stage
	Off
1st time	On
2nd time	Interval
3rd time + hold	Washer
4th time	Off

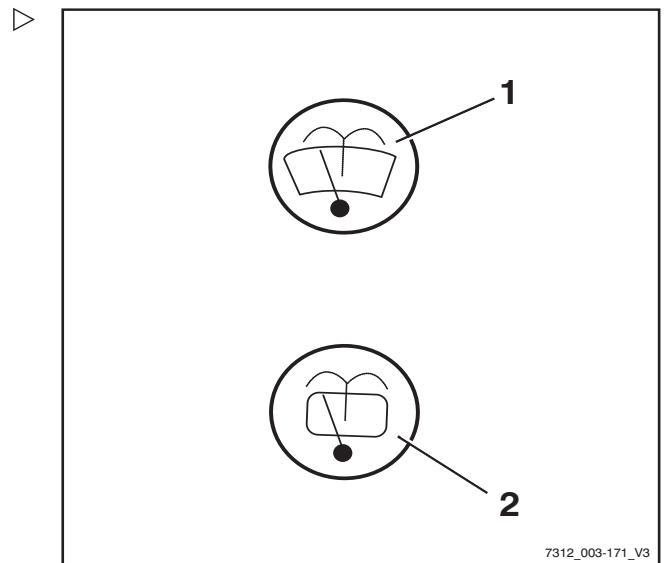

Filling the washer system

⚠ CAUTION

Components may become damaged due to the effects of frost!

Water expands when it freezes. If there is no anti-freeze in the washer system, the system may be damaged due to the build up of ice in freezing conditions.

- Always use washer fluid containing anti-freeze.

The windscreen washer reservoir is under the compartment behind the driver's seat. The sight glass (1) displays the fill level.

4

Operation

Auxiliary equipment

- Open filler cap (2) for the windscreen washer reservoir.
- Fill the windscreen washer reservoir with washer fluid and anti-freeze in accordance with the maintenance data table; see => Chapter "Maintenance data table", P. 5-325.
- Close lid.
- Operate washer system until washer fluid is discharged from the spray nozzles.

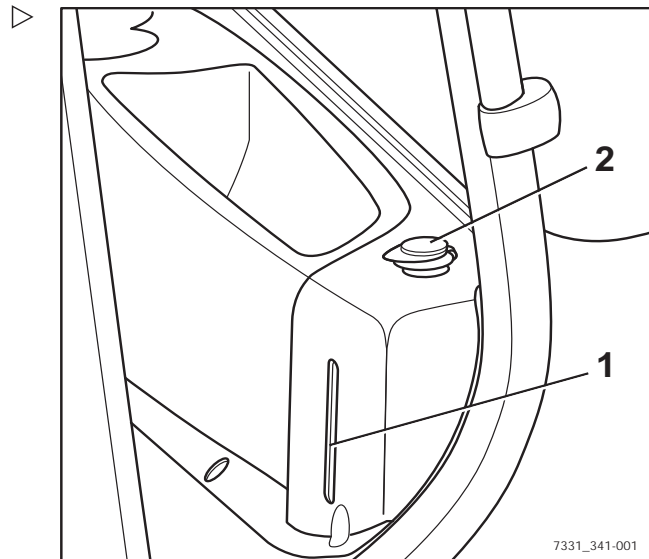

FleetManager (variant)

FleetManager is an equipment variant and can be fitted to the truck in different versions. The description and operation information can be found in the separate operating instructions for the corresponding FleetManager versions.

Shock recognition (variant)

The shock recognition is an equipment variant of the FleetManager (variant) in which an acceleration sensor is installed in the truck. The acceleration sensor records data arising from rapid accelerations or decelerations of the truck, e.g. in the event of an accident. This data can be electronically read out and evaluated.

- If you have any questions, please contact your authorised service centre.

12-V socket

To the right of the driver's seat, there is a 12-V socket (1) for connecting an external electrical consumer.

⚠ CAUTION

Risk of short circuit!

The nominal current of the connected consumer must not exceed 10 A.

- Before connecting, check the nominal current of the device in question.
-
- Open the dust guard cover (2).
 - Insert the plug of the device to be connected into the socket (1).
 - Place the dust guard cover on the plug.
 - Perform a functional check of the electrical connection on the connected device.

⚠ CAUTION

Malfunctions possible.

The exposed socket may become dirty and dusty if no plug is inserted or the dust guard cover is not closed. Over time, this can lead to problems with the electrical connection.

- Push the dust guard cover all the way down after using the socket.

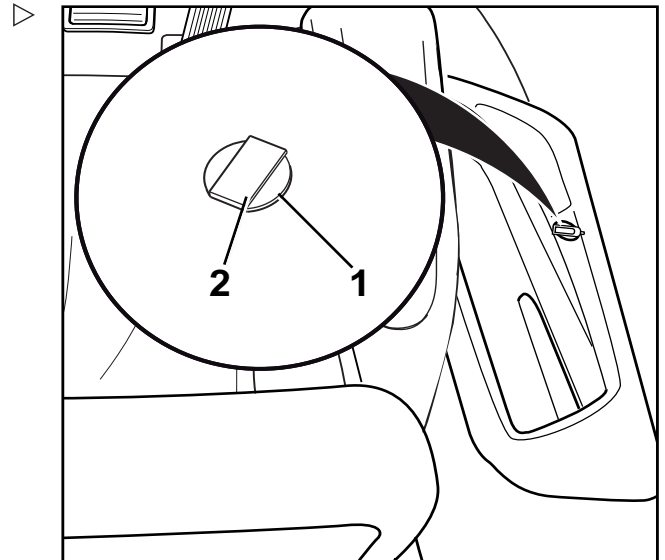

Driver restraint systems (variants)

Different driver restraint systems are available as variants for this truck. The description and operation for these systems can be found in the separate "Driver restraint systems" operating instructions.

Auxiliary equipment

Ceiling sensor (variant)

Description

The ceiling sensor (1) on the overhead guard  is an assistance system that automatically reduces the driving speed of the truck within halls. However, this assistance system does not release the driver from the responsibility of observing the speed limits on company premises.

Depending on the system setting, the ceiling sensor can detect overhead structures above the truck at a height of 2 m to 24 m above the sensor.

Operating the ceiling sensor system

The drivers are to be instructed on the use of the ceiling sensor system by the operating company.

When the driver enters a hall for the first time after starting work, he must be certain that the ceiling sensor system is functioning correctly. Despite the ceiling sensor system being installed, the driver must also check the speed indicator on the display-operating unit on a regular basis to ensure that he does not exceed the maximum speed permitted for the environment.

- **Entering a hall**

The ceiling detector system automatically detects whether the truck enters a hall. The system then automatically slows the truck to the maximum speed that is set for the hall.

- **Leaving a hall**

If the truck leaves the hall again, the ceiling detector system enables the maximum speed set for areas outside the hall. Due to the range of the sensor, this may not happen until the truck is a few metres away from the hall exit. Before the truck is able to accelerate to the maximum speed permitted for outdoor areas, the speed limitation must still be unlocked. To do this, release the

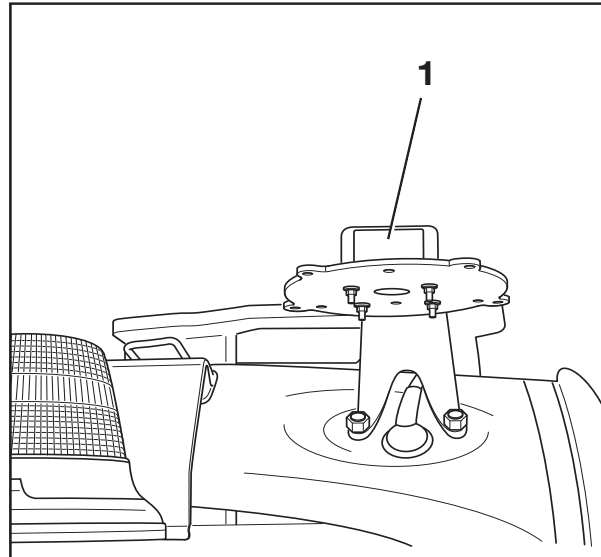

accelerator briefly and then operate the accelerator again.

- **Switching on the truck in a hall**

If the truck is switched on inside a hall, the ceiling detector system detects the hall ceiling and reduces the driving speed to the maximum speed that is set for halls.

Possible limitations for object recognition

- If the truck moves under larger overhead structures outdoors, e.g. a pedestrian bridge, the ceiling sensor system may interpret this overhead structure to be a hall ceiling and reduce the maximum speed.
- In rare cases, it may occur that the ceiling sensor system does not recognize a ceiling and does not then reduce the speed. This can happen if the signals from the ceiling sensor are insufficiently reflected due to the ceiling geometry; for example, if there are large window areas at a 45° angle.

In these cases, the sensitivity and the range of the ceiling sensor system must be adjusted. For more information, refer to the next chapter.

Changing the sensor settings

The ceiling sensor system is supplied by STILL with the following factory settings:

Sensitivity: **High**

Ceiling height: **24 m**

- Pull out the connecting cable from the sensor.

4

Operation

Auxiliary equipment

- On the underside of the assembly baseplate on the overhead guard, loosen the four nuts (1) on the sensor. ▷
- Carefully remove the sensor.

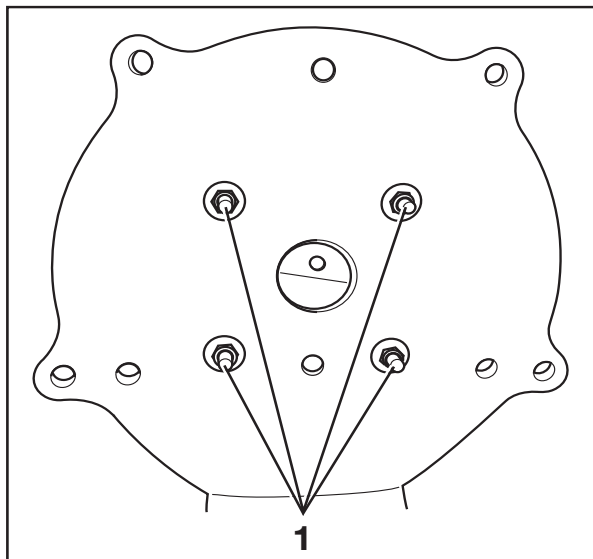

- Using the supplied key (2), open the sensor housing to gain access to the DIP switches. ▷

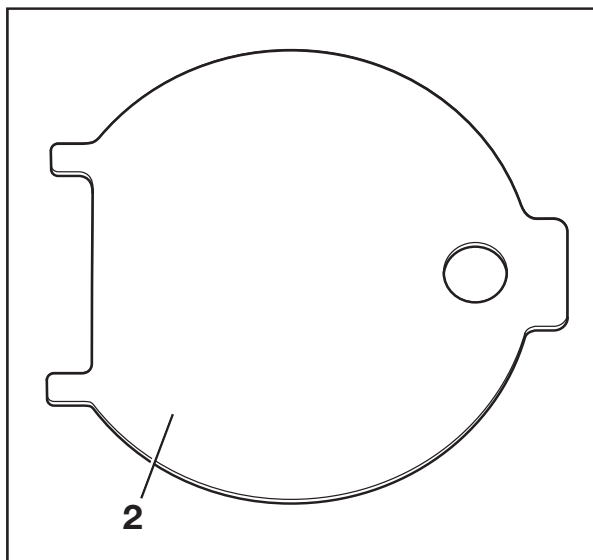

Operation

Auxiliary equipment

- Using the DIP switches "1" to "5" (3), adjust the range and the sensitivity of the sensor. The DIP switches can be adjusted using a small screwdriver.

CAUTION

The settings for DIP switches "6" to "8" are the factory settings of the manufacturer.

They must **not** be changed!

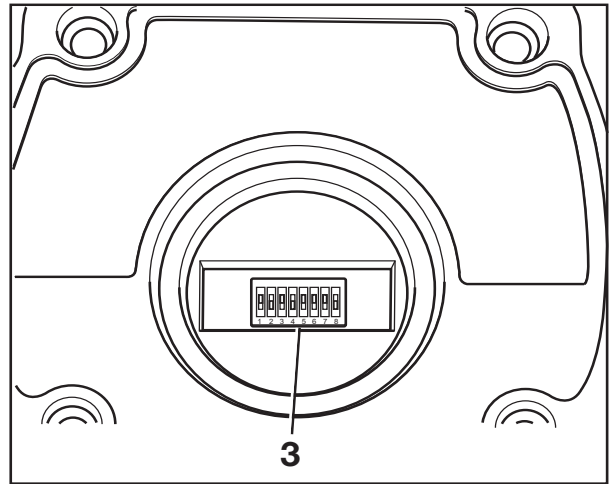

Factory settings of the manufacturer - do not change

DIP switch		
6	7	8
1	1	0

The possible settings for DIP switches "1" to "5" are shown in the following tables:

DIP switch			Range
1	2	3	
0	0	0	2 m
0	0	1	3 m
0	1	0	4 m
0	1	1	6 m
1	0	0	8 m
1	0	1	12 m
1	1	0	16 m
1	1	1	24 m

4	5	Sensitivity
0	0	Very high
0	1	High
1	0	Medium
1	1	Low

The sensor has different beam angles depending on the combination of range and



4

Operation

Auxiliary equipment

sensitivity that has been set. See the following table:

Sensitivity	Range	Beam angle
Low (1)	2 m	22.5°
	4 m	22.5°
	8 m	20°
	16 m	15°
	24 m	5°
Medium (2)	2 m	35°
	4 m	30°
	8 m	25°
	16 m	22.5°
	24 m	10°

Sensitivity	Range	Beam angle
High (3)	2 m	42°
	4 m	33°
	8 m	22.5°
	16 m	20°
	24 m	15°
Very high (4)	2 m	45°
	4 m	43°
	8 m	30°
	16 m	22.5°
	24 m	18°

Operation

4

Auxiliary equipment

Representation of the beam angle depending on the sensitivity of the sensor that has been set, from (1) "low" to (4) "very high".

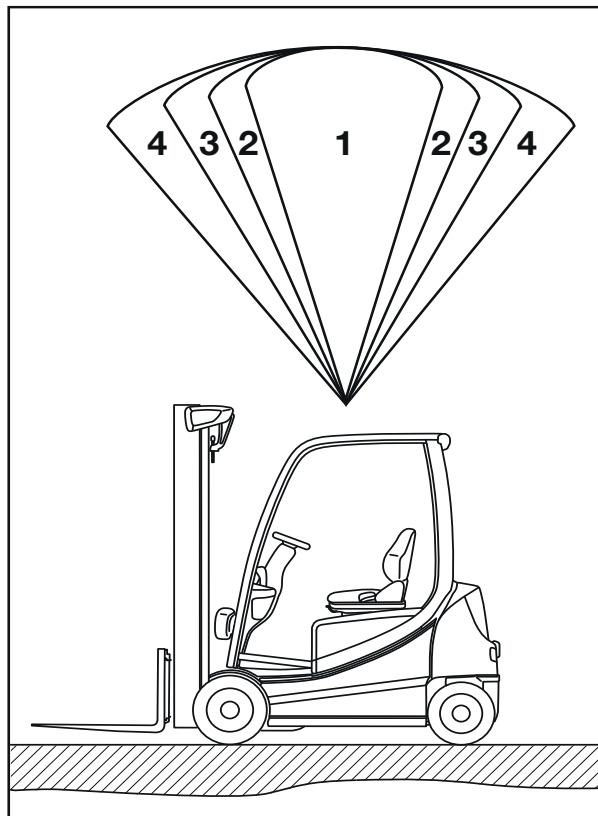

Additional labelling

Adhesive label next to the display-operating unit

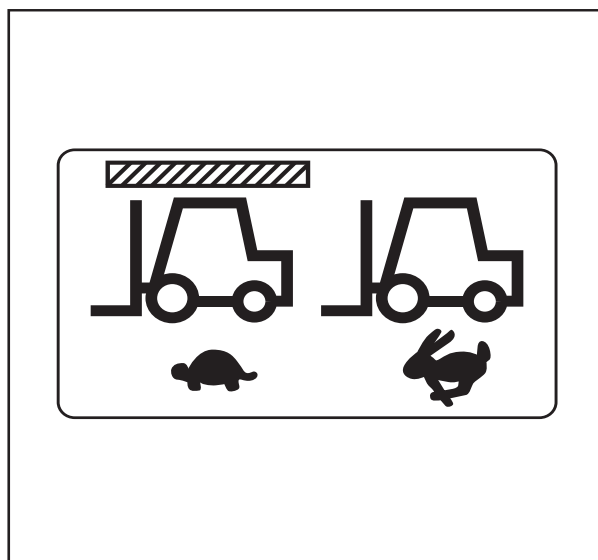

4

Operation

Cab

Cab

Opening the cab door

⚠ DANGER

There is a risk of damage caused by collision if the cab door opens while driving.

- The cab door must be latched securely in the engaged position.

Opening the cab door from the outside:

- Insert the key in the door lock (1), unlock and remove the key.
- Pull the door handle (2) and release the door lock.
- Open the cab door (3) by pulling outwards.

Opening the cab door from the inside:

- Take hold of the handlebar (4) and latch (5).
- Press the latch in and push the cab door outwards.

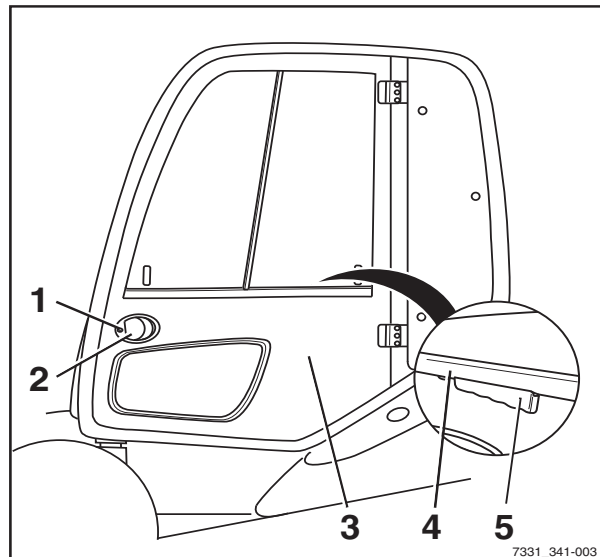

Closing the cab door

⚠ DANGER

There is a risk of damage caused by collision if the cab door opens while driving.

- The cab door must be latched securely in the engaged position.

Opening the side windows

⚠ WARNING

There is a risk of crushing between the window frame and side window from the side windows slipping inadvertently during travel.

- Make sure that the handle engages securely in the corresponding stop slot.

Opening the rear side window:

- Press the handle (2) together and slide the rear side window (1) forwards.
- Make sure that the handle engages in the stop slot (3).

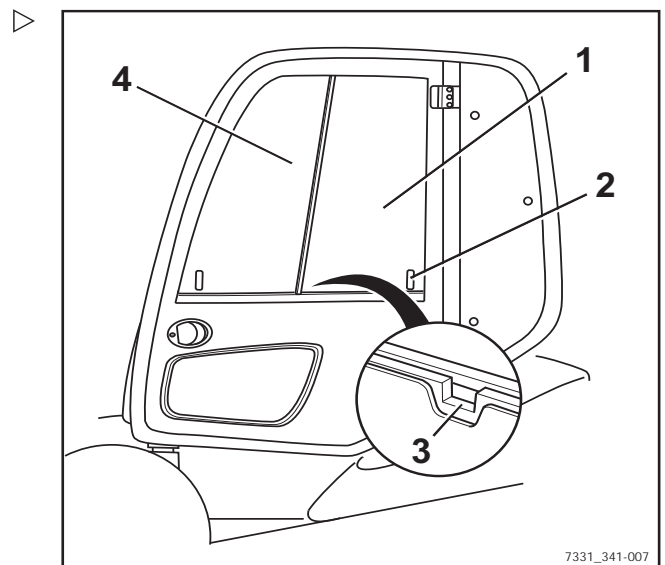

Opening the front side window:

The front side window (4) can be opened in the same way as the rear side window.

Closing the side windows

⚠ WARNING

There is a risk of crushing between the window frame and side window from the side windows slipping inadvertently during travel.

- Make sure that the handle engages securely in the corresponding stop slot.

Closing the rear side window:

- Press the handle (2) together and pull the rear side window (1) to the rear.
- Make sure that the handle engages in the stop slot (3).

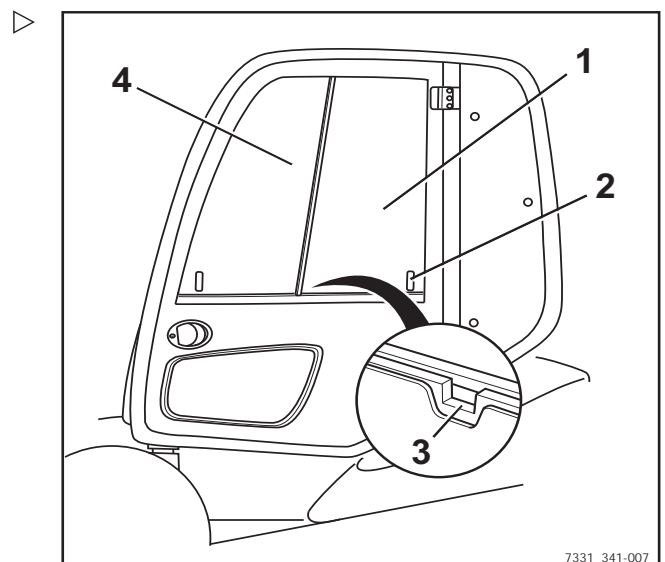

4 Operation

Cab

Closing the front side window:

The front side window (4) can be closed in the same way as the rear side window.

Operating the interior lighting

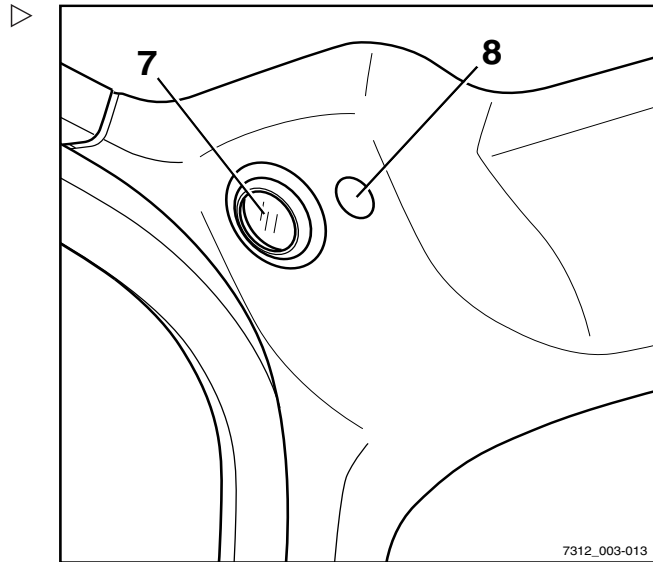

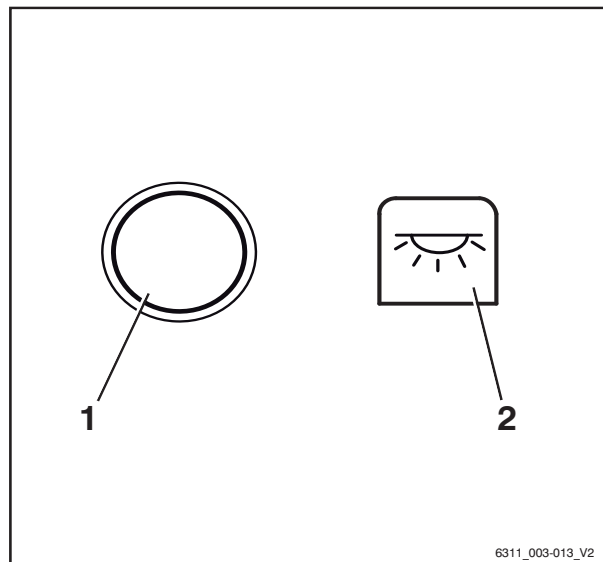

- Switch the interior lighting (7) on or off using the switch (8) or button (1).

The "interior lighting" symbol (2) appears in the display.



Operating the rear window heating

- Press Softkey  (1) to switch on the rear window heating. ▷

Rear window heating is switched on.
The  symbol is displayed.

- Press Softkey  (1) to switch off the rear window heating.

Rear window heating is switched off.
The  (2) symbol is displayed.

NOTE

Rear window heating will switch off automatically after approximately 10 minutes.

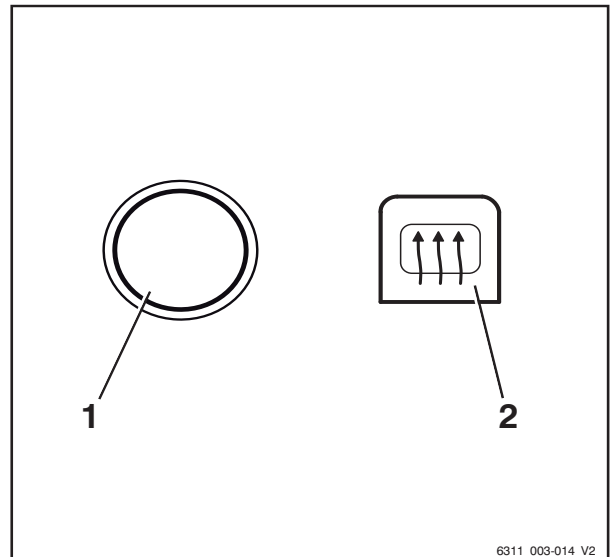

Radio (variant)

The radio (1) and the loudspeakers (2) are an equipment variant. If the truck is equipped with a radio and loudspeakers, they are integrated into the roof lining.

The description and operation can be found in the separate operating instructions for the radio.

WARNING

The driver's attention is adversely affected by operating the radio or listening to excessive volume while driving or handling loads. There is a risk of accident!

- Do not use the radio when driving or when handling loads.
- Set the radio volume so that you can still hear warning signals.

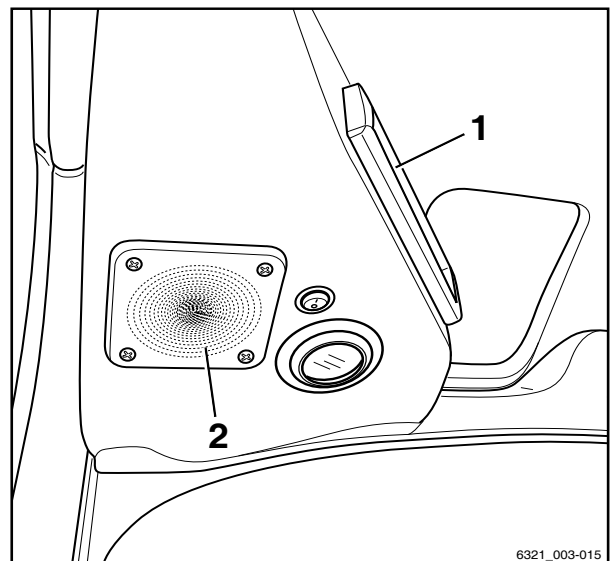

Heating system (variant)



⚠ DANGER

Risk of explosion!

There is a risk of explosion if the heater is operated in the vicinity of storage areas or similar areas where fuel vapours or coal dust, wood dust and crop dust can accumulate.

- Do not expose spray cans or gas cartridges to the flow of hot air.
- Do not operate the heater in hazardous areas.



⚠ DANGER

Risk of fire as a result of heat building up in the heating element!

Heat may build up if the air intake opening is blocked or the heating element collects dust. The heating element may overheat or short-circuit.

- Do not cover the air intake opening.
- Do not operate the heating system without a fresh air filter and recirculated air filter fitted.



⚠ DANGER

Risk of burns!

When the heating system is operated, the heating system housing becomes hot and can burn the skin if it is touched.

- Do not touch the heating system housing during operation.

⚠ CAUTION

Risk of blower malfunction!

The fresh air filter and recirculated air filter collect dust and dirt particles from the intake air. If the filter elements are not fitted, dust and dirt particles may block the blower.

- Do not operate the blower without a fresh air filter and recirculated air filter fitted.

Switching on the blower

- To switch on the blower, turn on the blower switch (1).

The blower runs at the speed level set at the switch.

Switching on the heating system

i NOTE

The heating system only heats up when the blower is switched on. If the blower switch is switched off, the heating system will not function, regardless of the position of the heater switch.

- To switch the heating system on, first switch on the blower switch (1) and then the heating switch (2).

The heating system is in operation. The air is heated up to the heat output level set at the heating switch (2).

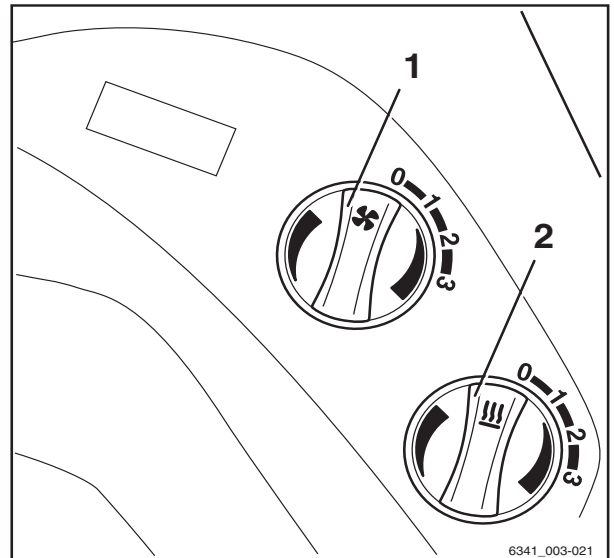

6341_003-021

Adjusting the air flow

- Adjust the air flow at the front outlet vents (3) and at the outlet vent in the footwell (4).

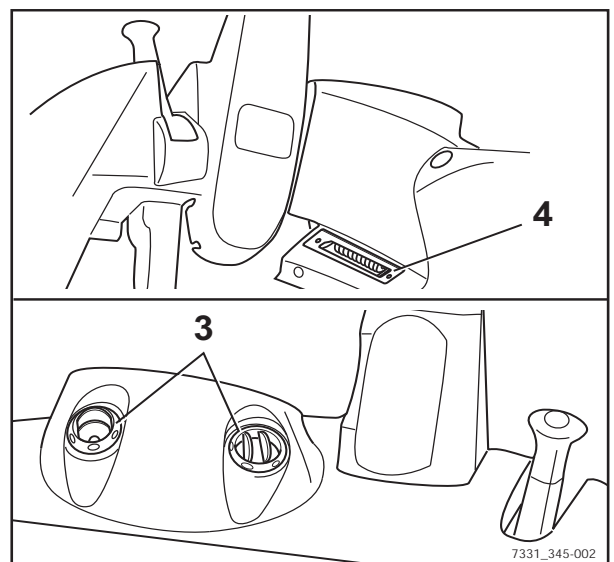

7331_345-002

4 Operation

Cab

Push-up roof window (variant)

⚠ WARNING

Risk of crushing!

- When closing the roof window, do not reach between the roof window and the overhead guard.
- Do not reach in to touch components as they are being closed.

The push-up roof window (1) is an equipment variant.

- To unlock and open the roof window, rotate the handle (2) in an anti-clockwise direction and use it to push the roof window upwards.

The roof window is held in the open position by means of gas springs (3).

- To close and lock the roof window, pull the roof window downwards using the handle and rotate the handle in a clockwise direction

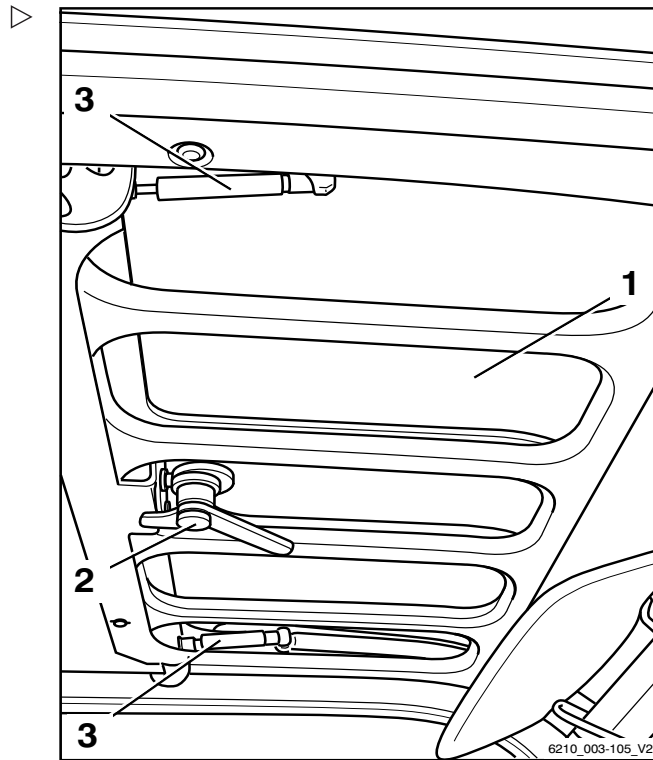

Clipboard (variant)

The clipboard (1) with reading lamp (2) is an equipment variant.

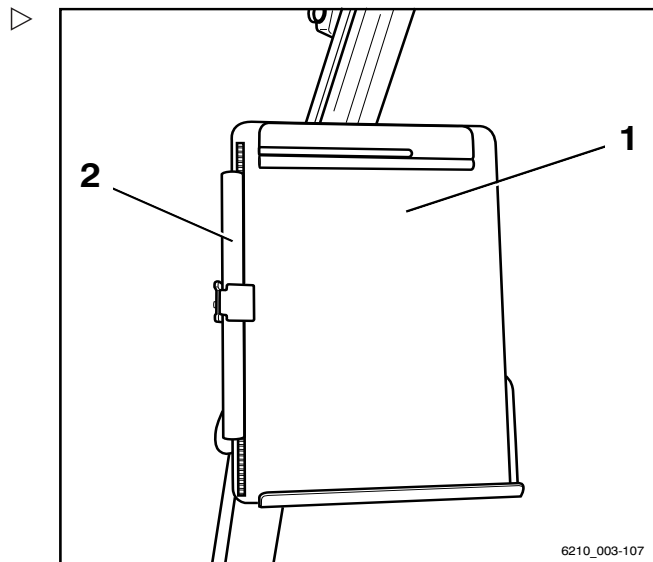

Trailer operation

Towed load

⚠ DANGER

There is an increased risk of accident when using a trailer.

Using a trailer changes the truck handling characteristics. When towing, operate the truck such that the trailer train can be safely driven and braked at all times. The maximum permissible speed when towing is 5 km/h.

- Do not exceed the permissible speed of 5 km/h.
- Do not couple the truck in front of rail vehicles.
- The truck must not be used to push any kind of trolley.
- It must be possible to drive and brake at all times.

⚠ CAUTION

Risk of damage to components!

The maximum towed load for occasional towing is the rated capacity specified on the nameplate. Overloading can lead to component damage on the truck. The sum of the actual towed load and the actual load on the fork must not exceed the rated capacity. If the towed load present corresponds to the rated capacity of the truck, it is not permitted to transport a load on the fork at the same time. The load can be distributed between the fork and the trailer.

- Check the load distribution and adjust to correspond to the rated capacity.
- Observe the permissible rigidity value of the tow coupling.

⚠ CAUTION

Risk of damage to components!

The maximum towed load only applies when towing unbraked trailers on a level surface (maximum deviation +/- 1%) and on firm ground. The towed load must be reduced if towing on gradients. If necessary, notify the authorised service centre of the application conditions. The service centre provides the required data.

- Inform the authorised service centre.

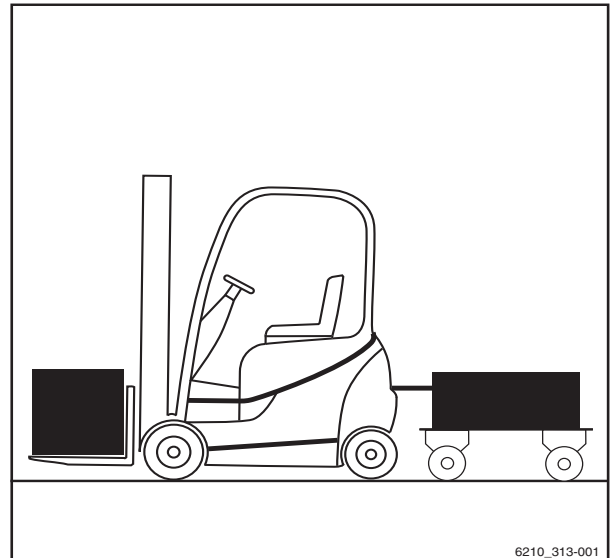

6210_313-001



Trailer operation

⚠ CAUTION

Damage to the tow coupling due to overloading!

Tow couplings RO*243 and RO*244 must be individually checked to ensure that they are suitable for the planned towing operation. The permissible rigidity value of the tow coupling must always be taken into account. The authorised service centre can check and/or confirm the maximum towed load for the planned towing operation.

- Observe the operating instructions for the tow coupling.
- Inform the authorised service centre.

⚠ CAUTION

Risk of damage to components!

A support load is not permitted.

- Do not use trailers with tillers supported by the tow coupling.

This truck is suitable for the occasional towing of trailers. If the truck is equipped with a towing device, this occasional towing must not exceed 2% of the daily operating time. The manufacturer must be consulted if the truck is to be used for towing on a more regular basis.

Coupling pin in the counterweight

Coupling the trailer

⚠ DANGER

Danger to life! If you briefly leave the truck to couple or uncouple the trailer, there is a risk of being run over by the truck rolling away.

- Apply the parking brake.
- Lower the fork to the ground.
- Turn off the key switch and remove the key.

Operation

4

Trailer operation

- Take measures to prevent the trailer from rolling away, e.g. use wheel chocks (1).

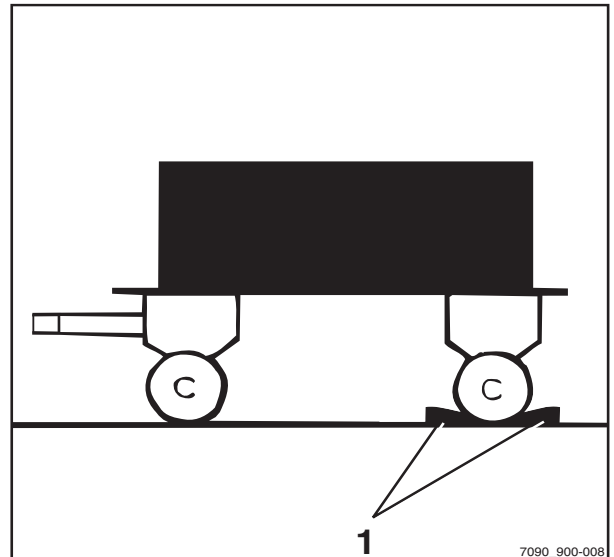

- Push the coupling pin (2) down, turn 90° and pull out.
- Adjust the tiller height.

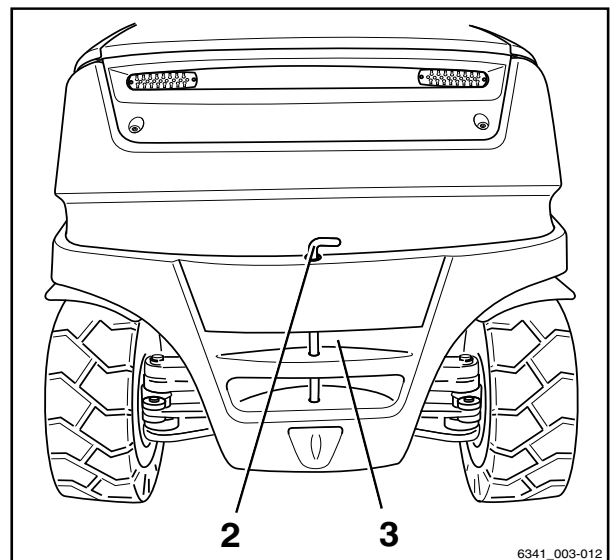

⚠ DANGER

People can become trapped between the truck and trailer.

When coupling, ensure that there are no persons present between the truck and the trailer.

- Slowly move the truck backwards.
- By moving the truck back, introduce the tiller into the recess (3) in the counterweight.

⚠ DANGER

If the coupling pin or securing bush are lost or destroyed during towing, the trailer will work loose and become uncontrollable. This poses a risk of accident!

- Only use genuine coupling bolts that have been checked.
 - Ensure that the coupling pin is correctly inserted and secured.
-
- Insert the coupling pin into the counterweight, press downwards against the spring pressure and turn 90° (the coupling pin is locked in this position).
 - Remove any items used to prevent the trailer from rolling away.

4

Operation

Trailer operation

Uncoupling the trailer

- Take measures to prevent the trailer from rolling away, e.g. use wheel chocks.
- Push the coupling pin (2) down, turn 90° and pull out.
- Slowly move the truck forwards and guide the tow-bar eye completely out of the counterweight.
- Insert the coupling pin into the counterweight, press downwards against the spring pressure and turn 90° (the coupling pin is locked in this position).

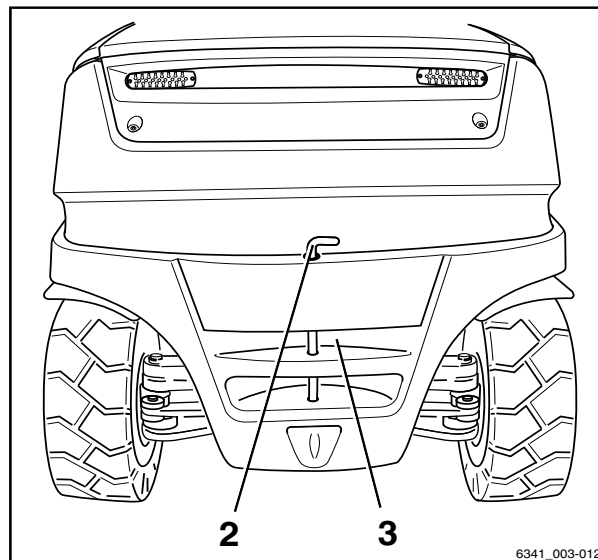

Automatic tow coupling

⚠ DANGER

Persons may become trapped between the truck and trailer.

When hooking up, ensure that no one is between the truck and trailer.

⚠ DANGER

Never jack up or crane load the truck on the tow coupling. The tow coupling is not designed for this and could be deformed or destroyed. The truck could fall off, with potentially fatal consequences!

- Use the tow coupling only for towing.
- For jacking up and crane loading, use only the designated lifting points.

⚠ DANGER

The tow coupling is not designed for support loads and could be deformed or destroyed. This could cause the supported load to fall, with potentially fatal consequences!

- The tow coupling should be subjected only to horizontal loads, i.e. the tiller must be horizontal.



⚠ DANGER

If you briefly leave the truck to couple or uncouple, there is a risk to life caused by the truck rolling away and running you over.

- Apply the parking brake.
- Lower the fork to the ground.
- Turn off the key switch and remove the key.

⚠ WARNING

Never reach between the coupling pins and the towing jaws. If the component moves suddenly there is a risk of injury!

- To release the coupling pin, actuate the corresponding lever or use a suitable device (e.g. assembly lever).
- When not in use, close the automatic tow coupling.

⚠ CAUTION

Risk of damage due to component collision.

A truck with tow coupling needs more room for manoeuvring due to its overhang. The tow coupling can damage the racking or the tow coupling itself when manoeuvring. If there is a collision with the tow coupling, check the tow coupling for damage such as cracks. A damaged tow coupling must not be used again.

- Always manoeuvre carefully and with sufficient room.
- In the case of a collision, check the tow coupling for damage.
- Replace tow coupling if damaged, if necessary contact the authorised service centre.

⚠ CAUTION

Risk of damage to the tow bar eye or tiller!

Due to the truck's rear wheel steering, the side slewing angle of the tiller may not be adequate. The coupling or the tiller may be damaged! The tow bar eye of the tiller must fit the tow coupling in terms of shape and size.

- Ensure that the tow bar eye and tiller fit correctly.
- Avoid sharp cornering.
- Exercise care when travelling and manoeuvring in reverse.

Trailer operation

⚠ CAUTION

Risk of component damage if the tiller in the tow coupling is tilted!

The tiller should if possible be kept horizontal when towing. This ensures a sufficient rotation range at the top and bottom. The authorised service centre can adjust the assembly height for the tow coupling to the tiller height if necessary.

- Make sure that the tiller is level.
- To change the coupling height, contact the authorised service centre.

Coupling model RO*243

⚠ CAUTION

Damage to the tow coupling due to overloading!

Tow couplings RO*243 and RO*244 must be individually checked to ensure that they are suitable for the planned towing operation. The permissible rigidity value of the tow coupling must always be taken into account. The authorised service centre can check and/or confirm the maximum towed load for the planned towing operation.

- Observe the operating instructions for the tow coupling.
- Inform the authorised service centre.

i NOTE

*Tow coupling RO*243 is intended for a tow-bar eye in accordance with DIN 74054 (bore diameter 40 mm).*

- Take measures to prevent the trailer from rolling away, e.g. use wheel chocks (1).
- Adjust the tow bar eye of the tiller so that it is at the centre of the towing jaws.

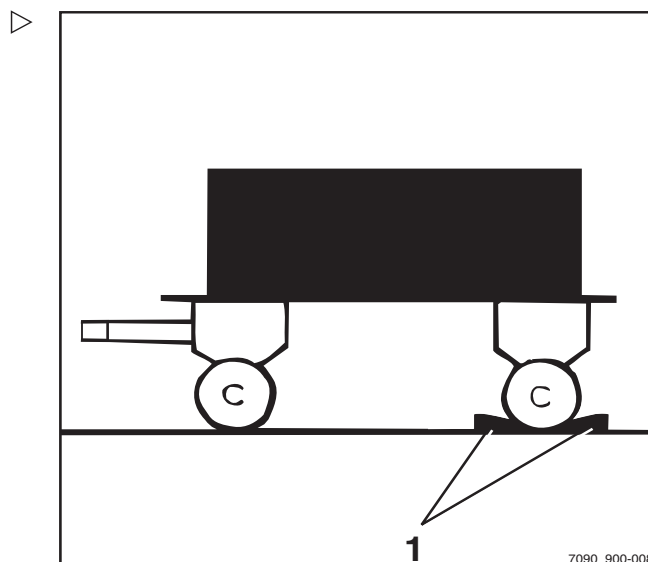

Operation

4

Trailer operation

- Pull out the safety handle (3).
- Push the hand lever (2) upwards.

⚠ DANGER

Persons may become trapped between the truck and trailer.

When hooking up, ensure that no one is between the truck and trailer.

⚠ CAUTION

When being coupled, the tow-bar eye must engage in the middle of the coupling jaw. Failure to follow these instructions could result in damage to the coupling jaw or to the tow-bar eye!

- Ensure that the tow-bar eye enters the coupling jaw centrally.

- Slowly move the truck back.

⚠ DANGER

If the coupling pin drops out during towing, the trailer will work loose and can no longer be controlled. There is a risk of accident!

A protruding safety handle means that the tow bar eye has not been coupled correctly. The trailer must not be towed in this condition.

- Ensure that the safety handle is flush with the securing bush.
- If the safety handle protrudes, repeat the coupling process.
- Remove any items used to prevent the trailer from rolling away.
- Tow the trailer.

Closing model RO*243 by hand

⚠ DANGER

Risk of injury from hand becoming trapped!

Do not reach into the coupling pin area with your hand. If, for example, a tow rope is to be secured in the tow coupling, use only a suitable device to close the tow coupling (e.g. assembly lever).

- Use a suitable device (e.g. assembly lever) to push the coupling pin up.

The coupling pin is released from the latch and then closes the tow coupling automatically.

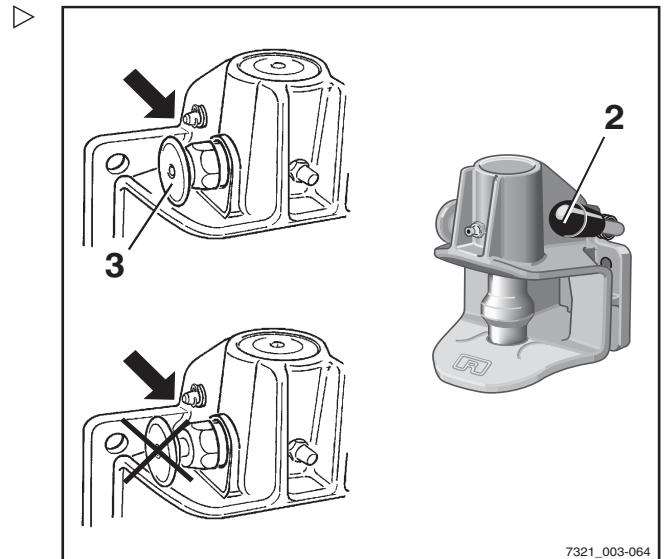

4

Operation

Trailer operation

Uncoupling model RO*243

- Take measures to prevent the trailer from rolling away, e.g. use wheel chocks.
- Pull out the safety handle (3).
- Push the hand lever (2) upwards.
- Slowly drive the truck forwards until the tow-bar eye and towing jaws are disconnected.
- Close the tow coupling by hand.

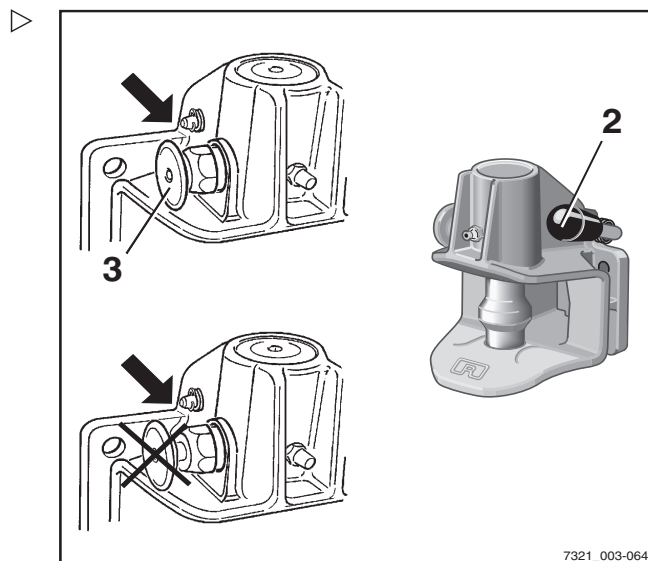

Coupling model RO*244 A

CAUTION

Damage to the tow coupling due to overloading!
Tow couplings RO*243 and RO*244 must be individually checked to ensure that they are suitable for the planned towing operation. The permissible rigidity value of the tow coupling must always be taken into account. The authorised service centre can check and/or confirm the maximum towed load for the planned towing operation.

- Observe the operating instructions for the tow coupling.
- Inform the authorised service centre.

NOTE

*Tow coupling RO*244 A is intended for a tow-bar eye in accordance with DIN 74054 (bore diameter 40 mm) or DIN 8454 (bore diameter 35 mm).*

- Take measures to prevent the trailer from rolling away, e.g. use wheel chocks.
- Adjust the tow bar eye of the tiller so that it is at the centre of the towing jaws.
- Push the hand lever (2) upwards until it snaps into place.

The tow coupling is opened.

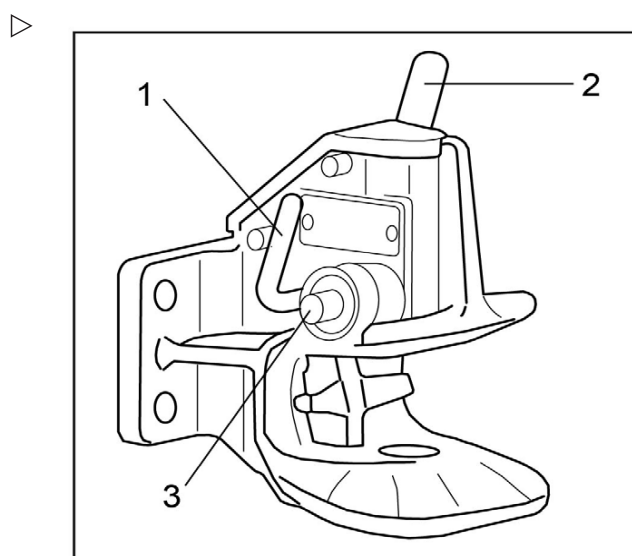

⚠ DANGER

Persons may become trapped between the truck and trailer!

When hooking up, ensure that no one is between the truck and trailer.

⚠ CAUTION

When being coupled, the tow-bar eye must engage in the middle of the coupling jaw. Failure to follow these instructions could result in damage to the coupling jaw or to the tow-bar eye!

- Ensure that the tow-bar eye enters the coupling jaw centrally.
- Move the truck back slowly until the tow bar eye is inserted centrally into the coupling jaw of the tow coupling and the coupling pin engages.

i NOTE

*The coupling pin is correctly engaged if the control pin (3) does **not** protrude out of its guide.*

⚠ DANGER

If the coupling pin drops out during towing, the trailer will work loose and can no longer be controlled. There is a risk of accident!

The control pin (3) must **not** protrude out of its guide.

- Ensure that the coupling pin is engaged correctly.
- If the coupling pin is not correctly engaged:
 - Remove any items used to prevent the trailer from rolling away.
 - Move the truck with the trailer forwards approx. 1 m and then move it back slightly.
 - On the coupling pin, check again that the control pin **does not** protrude out of its guide.
- Remove any items used to prevent the trailer from rolling away.
- Tow the trailer.

Trailer operation

Closing model RO*244 A by hand

⚠ DANGER

Risk of injury from hand becoming trapped!

Do not reach into the coupling pin area with your hand. If, for example, a tow rope is to be secured in the tow coupling, only actuate the tow coupling via the closing lever (1).

- Press the closing lever (1) downwards as far as it will go.

The tow coupling is closed.

Uncoupling model RO*244 A

- Take measures to prevent the trailer from rolling away, e.g. use wheel chocks.
- Push the hand lever (2) upwards until it snaps into place.

The tow coupling is opened.

- Slowly drive the truck forwards until the tow-bar eye and towing jaws are disconnected.
- Close the tow coupling by actuating the closing lever (1).

i NOTE

To protect the lower coupling pin bush against contamination, always keep the tow coupling closed.

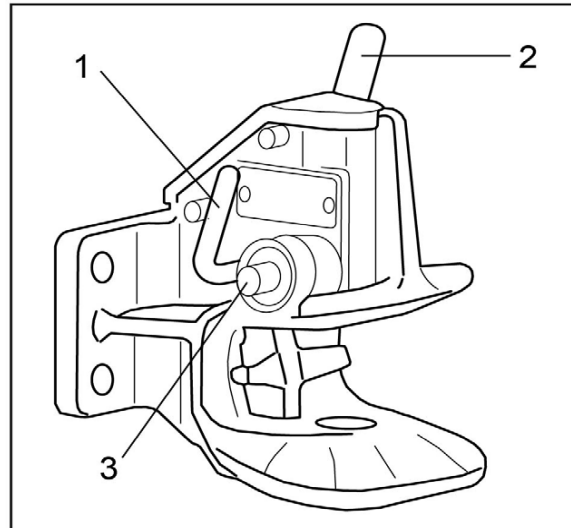

Coupling model RO*245

NOTE

Tow coupling RO 245 is intended for a tow-bar eye in accordance with DIN 74054 (bore diameter 40 mm) or DIN 8454 (bore diameter 35 mm).

- Take measures to prevent the trailer from rolling away, e.g. use wheel chocks.
- Adjust the tow bar eye of the tiller so that it is at the centre of the towing jaws.
- Push the hand lever (5) upwards.

The tow coupling is opened.

DANGER

Persons may become trapped between the truck and trailer!

When hooking up, ensure that no one is between the truck and trailer.

- Slowly move the truck back.

DANGER

If the coupling pin drops out during towing, the trailer will work loose and can no longer be controlled. There is a risk of accident!

A protruding safety handle means that the tow bar eye has not been coupled correctly. The trailer must not be towed in this condition.

- Make sure that the control pin does **not** protrude from the control bush.
 - Repeat the coupling process if necessary.
-
- Remove any items used to prevent the trailer from rolling away.
 - Tow the trailer.

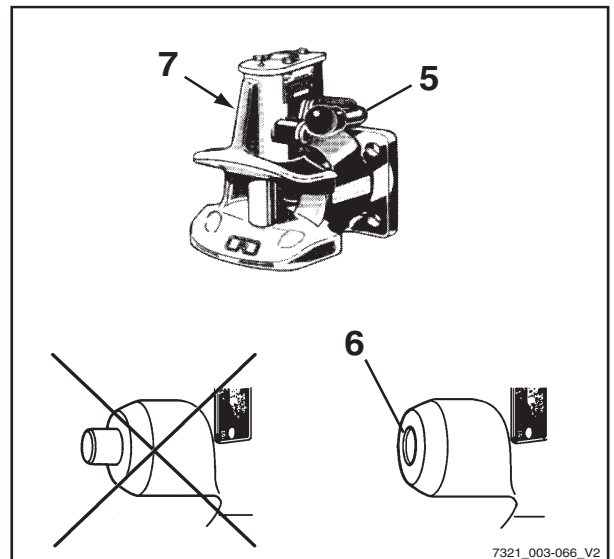

7321_003-066_V2

4

Operation

Trailer operation

Uncoupling model RO*245

- Take measures to prevent the trailer from rolling away, e.g. use wheel chocks.
- Push the hand lever (5) upwards.
- Slowly drive the truck forwards until the tow-bar eye and towing jaws are disconnected.
- Push the closing lever (7) on the left side of the tow coupling down as far as it will go.

The tow coupling is closed.

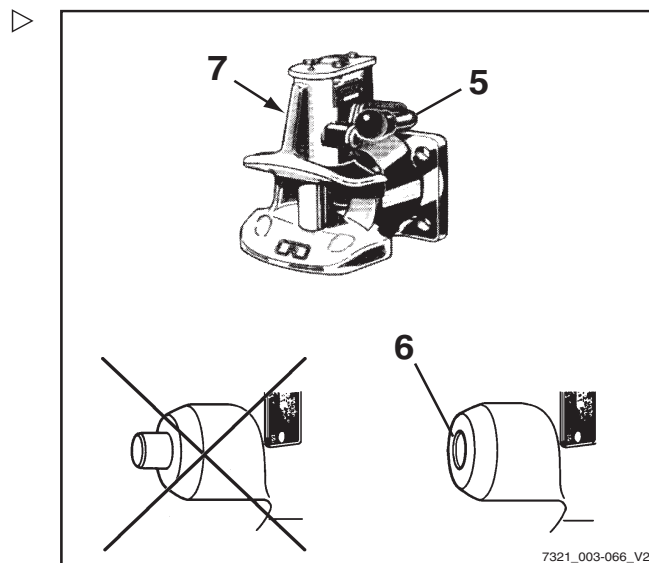

Towing trailers

- Drivers who are towing a trailer for the first time must practise driving with a trailer in a suitable area.
- When passing through narrow road areas (entrances, gates etc.), observe the dimensions of the trailer and load.
- When towing multiple trailers, ensure a sufficient minimum distance to fixed installations when turning and cornering.

The permissible length of the trailer trains depends on the roadways to be driven and may need to be determined during the test drive.

It is the responsibility of the operating company to instruct the drivers regarding the permissible number of trailers and, where required, any additional speed reductions on individual sections of the route.

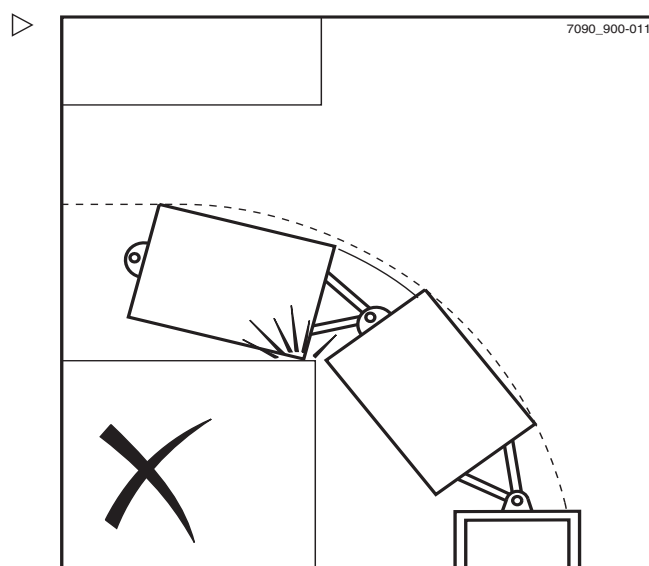

i NOTE

Please observe the definition of the following responsible persons: "operating company" and "driver".

Display messages

Display content

On the display of the display-operating unit, event-related messages may appear due to certain truck conditions.

The following types of message may appear individually or in combination:

- A graphic symbol (2)
- The message (3)
- An error code (4) consisting of a letter and a four-digit number

NOTE

Each time a message appears, the "Malfunction" display (1) also lights up.

Messages are always shown repeatedly and for a certain period of time, according to the event.

In the case of successive events, the respective messages are displayed one after another on the display.

After a few seconds, the display will alternate between the last shown operating display and the message.

The frequency of alternation depends on the type of event.

- If a message appears, follow these operating instructions.

Once the event is remedied, the message will disappear.

If a malfunction continues to occur, the message will continue to appear.

- Park the truck safely.
- Inform the authorised service centre.

Error code table

The table gives an overview of possible displays. In the "Comment" column you will find information on how to proceed should any of these messages appear.

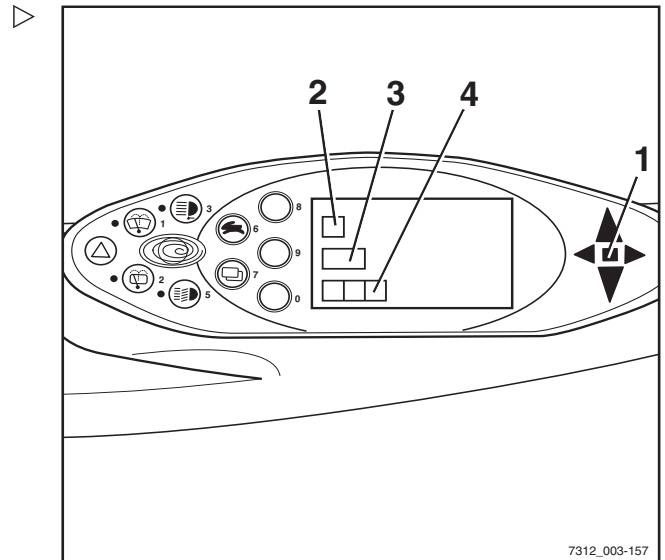



4

Operation

Display messages

Message text (English) / Error code	Comment
OVERHEATING A5022	Traction motor(s) is/are too hot. 1st phase: regulation of acceleration and speed. 2nd phase: limitation of phase current in converter (emergency driving function is retained). The error automatically disappears as soon as the temperature is below the limit. If the error occurs more frequently, notify your authorised service centre.
OVERHEATING A5364	Pump converter is too hot. Notify your authorised service centre.
ACCELERATOR A3002 A3003 A3004 A3005 A3006 A3007 A3505	Sensor fault, truck cannot be driven. Notify your authorised service centre.
ACCELERATOR A3008	Accelerator voltages (for dual pedal) do not match; truck cannot be driven. Notify your authorised service centre.
ACCELERATOR A3811	Accelerator configuration is invalid. Truck cannot be driven. Notify your authorised service centre.
BRAKE SENSOR A3016 A3017	Sensor fault; truck can only be driven at emergency mode speed. Notify your authorised service centre.
CONFIGURATION A2111 A3801 A3812	Parameterisation error; drive unit and hydraulic drive not functioning. Notify your authorised service centre.
SEAT SWITCH A302	Seat switch has not been actuated for approx. 8 hours. Truck may still drive at a reduced speed and with reduced lifting capacity. Stand up briefly and then sit down again. If this does not resolve the problem, contact your authorised service centre.
STEERING A3215 A3216 A3570	Sensor fault; truck moves at emergency mode speed. Notify your authorised service centre.
DRIVE DIRECTION A3020	Switch error; no or limited drive unit function. Notify your authorised service centre.
LIFTING A3102 A3103	Sensor fault; no or limited hydraulic drive function. Notify your authorised service centre.



Message text (English) / Error code	Comment
TILTING A3107 A3108	Sensor fault; no or limited hydraulic drive function. Notify your authorised service centre.
MAST VERTICAL A3130 A3131 A3132	No hydraulic function. Turn off "lift mast vertical position". Notify your authorised service centre.
MAST VERTICAL A3135	No hydraulic function. Turn off "lift mast vertical position". Notify your authorised service centre.
EXT1 A3112 A3113	Sensor fault; no or limited hydraulic drive function. Notify your authorised service centre.
EXT2 A3117 A3118	Sensor fault; no or limited hydraulic drive function. Notify your authorised service centre.
POWER SUPPLY A2242	Transmitter power supply short circuit. Truck cannot be driven. Notify your authorised service centre.
SURVEILLANCE A2801 A2802 A2808 A2809 A2810 A2815	Drive unit not functioning. Release accelerator pedal. If this error occurs sporadically, it can be tolerated. If the operational capacity is impaired, notify your authorised service centre.
SURVEILLANCE A2803 A2806	Drive direction is set to neutral. Reselect the drive direction. If this error occurs sporadically, it can be tolerated. If the operational capacity is impaired, notify your authorised service centre.
SURVEILLANCE A2817	Truck is not ready for operation. Turn the key switch to the zero position and restart. If this error occurs sporadically, it can be tolerated. If the operational capacity is impaired, notify your authorised service centre.
SURVEILLANCE A2804 A2805 A2807 A2811 A2812 A2813 A2814 A2816 A2818	No or limited drive unit function. Notify your authorised service centre.

Display messages

Message text (English) / Error code	Comment
SURVEILLANCE A2295	No or limited function of drive unit and hydraulic drive. Notify your authorised service centre.
DRIVE A5031 A5041 A5046 A5301 A5331 A5361	Temperature sensor fault Notify your authorised service centre.
BATTERY CHANGER A5910	The support roller for the hydraulic battery carrier is not fully extended Notify your authorised service centre.
BATTERY CHANGER A5920	Hydraulic pump of the hydraulic battery carrier is overheating. Allow the truck to cool down for 1 hour.
BATTERY CHANGER A5930	Button error Notify your authorised service centre.
BATTERY CHANGER A5931	Plausibility error with potentiometer for hydraulic battery carrier Notify your authorised service centre.
CONTROL UNIT A3305	CIO not functioning. Notify your authorised service centre.
PARKING BRAKE OIL PRES - SURE A3043	Parking brake oil pressure too low; the drive unit is locked. If this message remains permanently displayed, notify your authorised service centre.
PARKING BRAKE OIL PRES - SURE A3049	Parking brake oil pressure low; truck only moves at emergency mode speed. If this message remains permanently displayed, notify your authorised service centre.

General messages

NOTE

Some of the following messages are equipment-specific and may not appear on the display and operating unit of every truck. The following messages are therefore intended only as a reference.

SERVICE BRAKE message

If the message SERVICE BRAKE appears on the display, notify the authorised service centre.

- Park the truck securely for checking by the authorised service centre.
- If multi-disc brakes in the drive wheel units are blocked, tow the truck.

APPLY HANDBRAKE message

DANGER

Risk of fatal injury from being run over if the truck rolls away!

Parking the truck without the parking brake applied is dangerous and is not permitted.

- The truck must not be parked on a slope.
- Only leave the truck when the parking brake has been applied.
- In emergencies, secure the truck using wedges on the side facing downhill.

NOTE

The truck is equipped with a negative spring-operated brake. Switching off the truck will block the multi-disc brakes in the drive wheel units after a few minutes. However, the truck can still roll until the drive wheel units are blocked. For this reason, the parking brake must always be applied before you leave the truck!

If you park the truck without applying the parking brake and then vacate the driver's seat, the APPLY HANDBRAKE message will appear in the display (variant). An optional signal tone sounds.

- Apply the parking brake.

The APPLY HANDBRAKE message disappears.

If the truck moves even though the parking brake is applied:

- Drive the truck onto level ground and park it safely. Secure it with wedges if necessary.
- Notify the authorised service centre.

BRAKE SENSOR message

If the BRAKE SENSOR message appears in the display, the maximum driving speed will be



Display messages

reduced. The brake sensor in the brake pedal must be checked.

- Notify the authorised service centre.

CODE DENIED message

If the message **CODE DENIED** appears on the display, the driver PIN has been entered incorrectly three times. The input is then locked for five minutes before another attempt can be made.

- Enter the driver PIN again after five minutes.

ACCELERATOR message

If the **ACCELERATOR** message appears on the display, the truck will remain stationary. The accelerator must be checked.

- Notify the authorised service centre.

SWITCH OFF TRUCK? message

If the message **SWITCH OFF THE TRUCK?** appears on the display, the switching-off of the truck is verified.

- Press the corresponding softkey on the display and operating unit to switch off the truck or cancel the operation.

PARKING BRAKE ACTIVE message

If the electric parking brake is applied, the **PARKING BRAKE ACTIVE** message appears on the display for 5 seconds.

- Release the parking brake to enable driving mode.

RELEASE PARKING BRAKE message

If the message **RELEASE PARKING BRAKE** appears on the display, driving mode cannot be enabled until the parking brake has been released by pressing the button.

- Release the parking brake by pressing the button.

PARKING BRAKE: APPLY HANDBRAKE! message

If the message PARKING BRAKE : APPLY HANDBRAKE ! appears on the display, the electric parking brake is faulty.

- Release the parking brake by pressing the button.

LOWER FORKS message

⚠ DANGER

There is a risk of fatal injury from a falling load or parts of the truck being lowered!

Parking the truck with the load lifted is dangerous and is not permitted under any circumstances! The increased safety provided by this function must not be misused in order to take safety risks.

- Lower the load fully before leaving the truck.

The fork is not lowered.

If the fork is above the height sensor, the key switch is turned off and the seat vacated, the LOWER FORKS message appears in the display (variant). An optional signal tone sounds.

- Lower the fork to the ground.

The message LOWER FORKS disappears.

STEERING message

If the STEERING message appears in the display, the truck will only move at emergency mode speed. The steering angle sensor must be checked.

- Notify the authorised service centre.

TILTING SPEED message

If the message TILTING SPEED appears on the display after the welcome screen, the tilting speed of the lift mast on this truck is significantly higher than on previous trucks in this family.

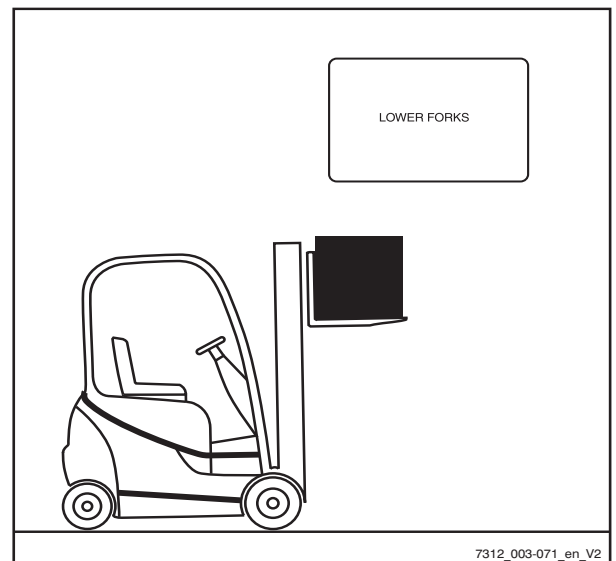

7312_003-071_en_V2

Display messages

EMERGENCY SWITCH message

⚠ WARNING

No electric braking assistance is available when the emergency off switch is actuated!

Actuating the emergency off switch will disconnect the drives from the power supply.

- To brake, actuate the service brake.

The truck is equipped with an emergency off switch. When this switch is actuated, the driving functions and the functions of the working hydraulics are blocked.

The **EMERGENCY SWITCH** message appears periodically when the following criteria are met:

- The key switch is set to stage "I"
- The emergency off switch is actuated
- An operating device is actuated

? VERTICAL POSITION

If the message **? VERTICAL POSITION** appears on the display, calibration of the "vertical lift mast position" has been activated.

- Save the mast position or cancel the calibration.

REFERENCE CYCLE message

If the fork was lowered after the truck was switched off, the control electronics do not know the position of the fork when the truck is restarted. The truck will only travel at a reduced driving speed. Depending on the position of the fork, the message **REFERENCE CYCLE** (variant) may appear in the display. To align the position with the control electronics, the fork must be raised.

- Switch on the key switch.

The truck will only travel at a reduced driving speed. The message **REFERENCE CYCLE** may appear in the display.

- Raise the fork.

The message **REFERENCE CYCLE** goes out, or now appears in the display for the first time and then goes out.

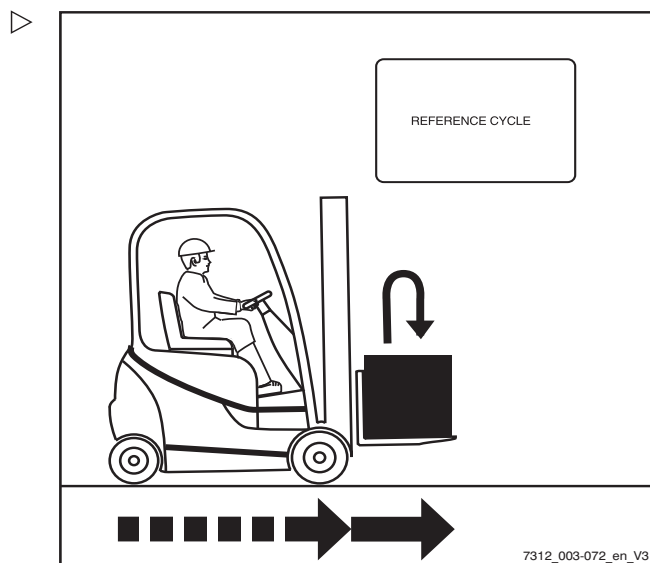

7312_003-072_en_V3

- To drive again, lower the fork to a maximum of 300 mm above the ground.

The truck can now be driven again with no speed limitation.

SAFETY BELT message



⚠ DANGER

Risk of fatal injury in the event of falling from the truck if it tips over!

If the truck tips over, the driver is at risk of injury even if a restraint system is used. The risk of injury can be reduced by using a combination of a restraint system and a seat belt. In addition, the seat belt protects against the consequences of rear-end collisions and falling off ramps.

- We recommend that you always use the seat belt.

This device (variant) ensures that if the seat belt is not being used or is being used incorrectly, the truck will only drive slowly or (optionally) will not drive at all.

Depending on the configuration selected, the working hydraulics functions (lifting/tilting) are either available as normal, slowed down or not available at all.

The SAFETY BELT message with the restricted driving and lifting functions is triggered by the following circumstances:

- Seat belt not worn and driver's seat occupied
 - The seat belt is constantly fastened but the driver's seat is only occupied afterwards
 - The seat belt is not fastened until after the key switch has been switched on
 - The seat belt is unfastened while driving
- If the SAFETY BELT message appears, fasten the seat belt in accordance with the regulations.

The truck can again be operated without restrictions.

If the seat belt is released while driving, the truck will be limited to low driving speeds or will be braked to a halt.

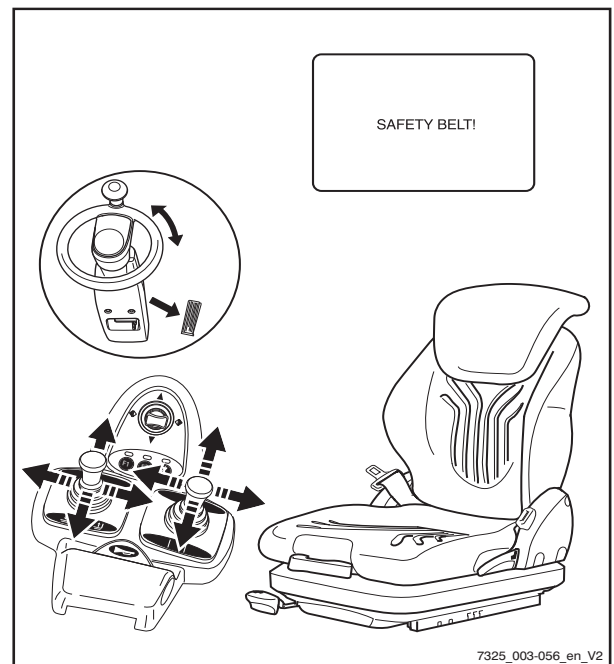

7325_003-056_en_V2

Display messages

DANGER

Risk of accident!

- The speed must be adjusted to suit the driving situation!

The increased safety provided by this function must not be misused in order to take safety risks.

ARE YOU SURE ? message

If the message ARE YOU SURE ? appears on the display, a prior prompt is verified.

- Press the corresponding softkey on the display and operating unit to continue or to cancel the operation.

SEAT SWITCH message

The truck is equipped with a seat switch.

If the SEAT SWITCH message appears, the driving functions and the working hydraulics are blocked.

The SEAT SWITCH message is triggered by the following situations:

- The seat switch is not actuated while the accelerator pedal or steering wheel is actuated
- The seat switch is not actuated while the operating device for the working hydraulics is actuated
- The shift time has been exceeded
- The operating time has been exceeded

NOTE

The operating devices shown in the following illustrations are only examples and may differ from the equipment in your truck.

Operation

4

Display messages

The seat switch is not actuated while the accelerator pedal or steering wheel is actuated

The accelerator pedal or the steering wheel is actuated, even though no one is sitting in the driver's seat. The message SEAT SWITCH appears on the display. The truck will not move.

- Sit in the driver's seat and fasten the seat belt.

The truck can be driven again without restrictions.

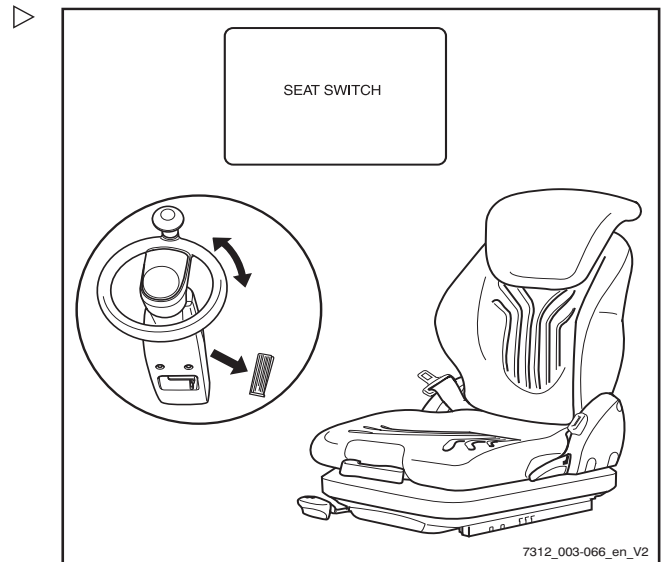

The seat switch is not actuated while the operating device for the working hydraulics is actuated

An operating device for the working hydraulics is actuated, even though no one is sitting in the driver's seat. The message SEAT SWITCH appears on the display. The working hydraulics functions cannot be executed.

- Sit in the driver's seat and fasten the seat belt.

The working hydraulics can be operated again.

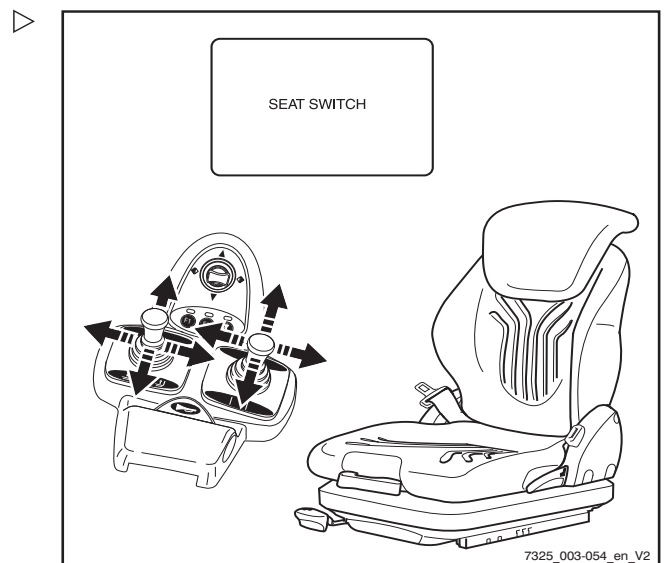

4

Operation

Display messages

The shift time has been exceeded

i NOTE

The shift time is adjustable.

If the key switch is switched on and the driver does not leave the seat before the set shift time is exceeded, SEAT SWITCH appears on the display. This is also the case if an operating device for the working hydraulics or the accelerator pedal is actuated. Depending on the configuration, the working hydraulic functions can be executed normally, only slowly or not at all.

- Stand up briefly from the seat, sit back down again and fasten the seat belt.

The truck can again be operated without restrictions.

The operating time has been exceeded

i NOTE

The operating time is adjustable.

If the key switch is switched on, the parking brake is released and the driver does not leave the seat before the set operating time is exceeded, and if neither the operating devices for the working hydraulics nor the accelerator pedal are actuated during this time, SEAT SWITCH appears on the display. The truck will not move. Depending on the configuration, the working hydraulic functions can be executed normally, only slowly or not at all.

- Stand up briefly from the seat, sit back down again and fasten the seat belt.

The truck can again be operated without restrictions.

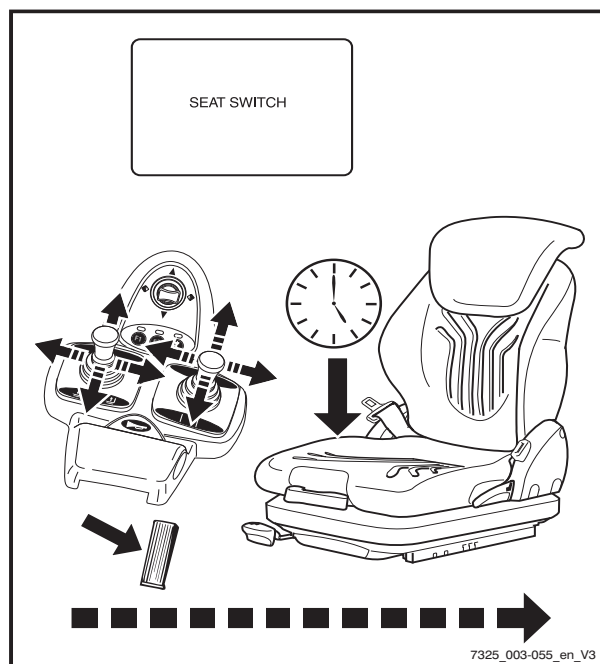
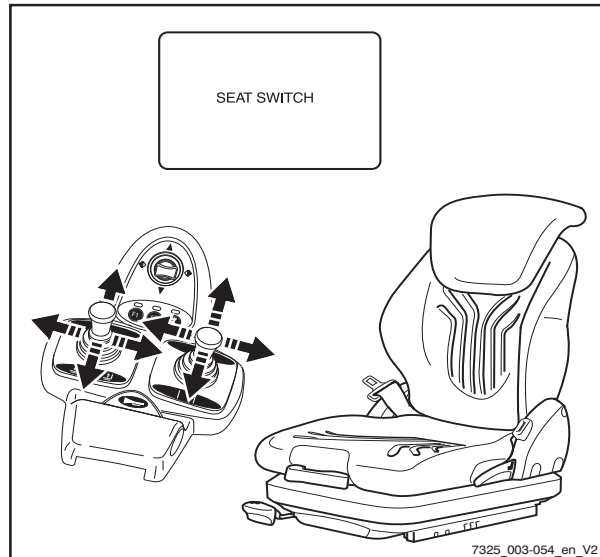

OVERHEATING message

If the message OVERHEATING appears on the display, the traction motors have overheated. The acceleration and the speed of the truck are reduced.

- Allow the truck to cool down.
- If the error persists, contact your authorised service centre.

SURVEILLANCE message

If the SURVEILLANCE message appears in the display, there is a fault in the process monitoring.

This shuts off the drive unit.

- Switch the key switch to the "0" position and then back to the "I" position.
- Start the engine.
- Release accelerator pedal.
- Select the drive direction again.

NOTE

If this error occurs sporadically, it can be tolerated. If the operational capacity is impaired, notify your authorised service centre.

NOT VALID message

If the message NOT VALID appears on the display, an incorrect driver PIN has been entered when entering the access code.

- Once the message goes out, enter the driver PIN again.

Drive-specific messages

Message ! PARKING BRAKE OIL PRESSURE

If the following message appears in the display when the accelerator pedal is actuated:

! PARKING BRAKE OIL PRESSURE, the service brake of the truck is not ready for use.

The driving speed is limited to 5 km/h.

When the service brake is ready for operation, the message disappears. The speed limitation is cancelled.

MOT/GEN.-TEMP. message

If the MOT/GEN. - TEMP. message appears, the traction motor or the generator is overheated or a cable is broken.

Display messages

- Interrupt work and allow the truck to cool down. Do not switch off the key switch.

NOTE

If the operational capacity is impaired, notify your authorised service centre.

OVERHEATING message

If the message OVERHEATING appears in the display, the traction motors have overheated. The acceleration and the speed of the truck are reduced.

- Allow the truck to cool down.
- If the error persists, contact your authorised service centre.

CLOSE THE DOOR message

If the message CLOSE THE DOOR (variant) appears in the display, the battery door is not shut correctly. The truck will not move.

- Close the battery door.

LIFT HEIGHT message

Speed limitation with a raised load (variant)

This function makes sure that the truck can only move slowly when a load is lifted.

DANGER

Risk of accident!

Before using this function, familiarise yourself with the altered driving characteristics of the truck!

Optionally, the truck can have altered acceleration behaviour and/or braking characteristics.

DANGER

Risk of accident!

Driving with a lifted load is prohibited, because the truck can overturn due to the high centre of gravity.

Because the limits determined by physics cannot be altered, the increased safety provided by this function must not be misused in order to take safety risks.

If the fork is raised above a certain height, the following happens:

Lifting the load at a standstill

The key switch is switched on. The driver sits on the seat with the belt fastened. The load is lifted. The display briefly shows the flashing message **LIFT HEIGHT**. The truck will only travel at a reduced driving speed.

- Lower the fork (load) to just above the ground.

The truck can now be driven again with no speed limitation.

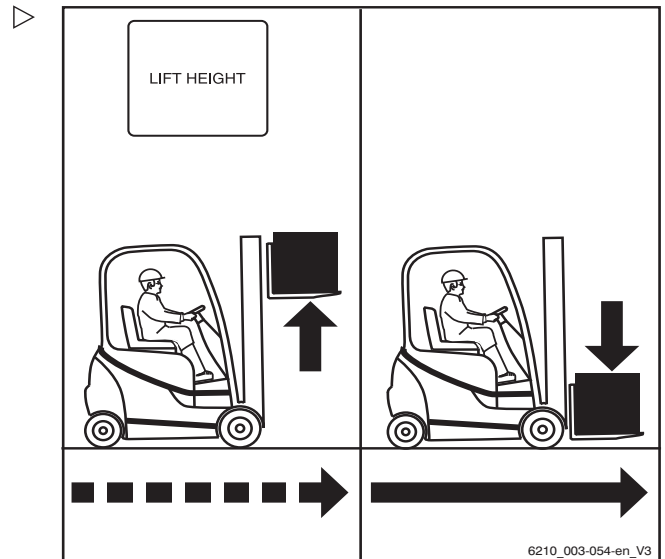

Lifting the load while driving

If you are travelling with the load during a stacking/unstacking operation and lift the load while travelling, the flashing message **LIFT HEIGHT** appears briefly in the display. The truck will travel slowly or will be braked.

- Lower the fork (load) to just above the ground.

The truck can now be driven again with no speed limitation.

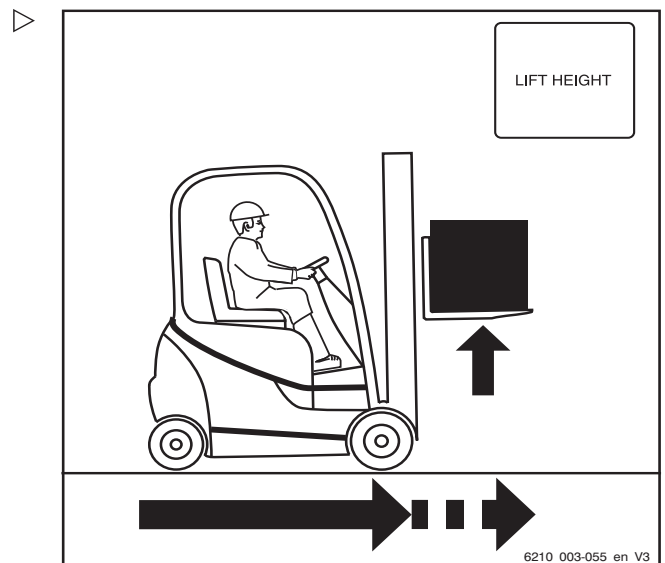

Connecting and disconnecting the battery male connector

Connecting and disconnecting the battery male connector

Connecting the battery male connector

⚠ CAUTION

Risk of damage to the battery male connector when connecting!

If the battery male connector is connected while the key switch is switched on under load, a jump spark will be produced. The discharge spark can damage the contacts and considerably shorten the service life of the contacts.

- Switch off the key switch.
- Only connect the battery male connector while the key switch is switched off.



⚠ CAUTION

There is a risk of short circuit if the cables are damaged!

- Do not crush the battery cable when closing the battery cover.

- Switch off the key switch.
- Open the battery cover.
- Ensure that the battery male connector and the plug connection are dry, clean and free of foreign objects.
- Hold the battery male connector (2) by the handle (1) and insert the battery male connector into the plug connection on the truck.
- Push the fastener (3) completely to the right to retract the battery male connector into the plug connection and to secure the battery male connector in position.
- Ensure that the battery cable does not come into contact with the battery cover.
- Close the battery cover.

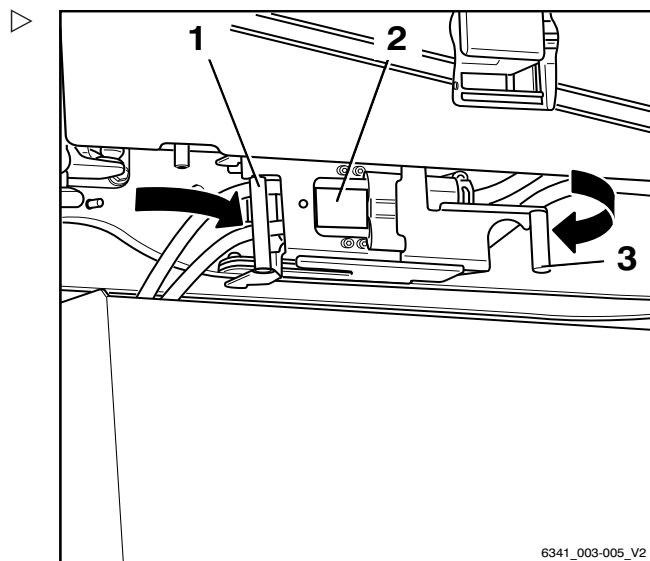

6341_003-005_V2

Disconnecting the battery male connector

⚠ CAUTION

Risk of damage to the battery male connector when disconnecting!

If the battery male connector is disconnected while the key switch is switched on under load, an arc will be produced. The arc can damage the contacts and considerably shorten the service life of the contacts.

- Switch off the key switch.
- Only disconnect the battery male connector while the key switch is switched off.
- Do not disconnect the battery male connector while under load, except in an emergency.



⚠ CAUTION

There is a risk of short circuit if the cables are damaged!

- Do not crush the battery cable when closing the battery cover.

- Switch off the key switch.
- Open the battery cover.
- Pull the fastener (4) to the left and open the fastener.
- Disconnect the battery male connector (3) from the plug connection by pulling the handle (2) in the direction of the arrow.
- Check the battery cable for damage.

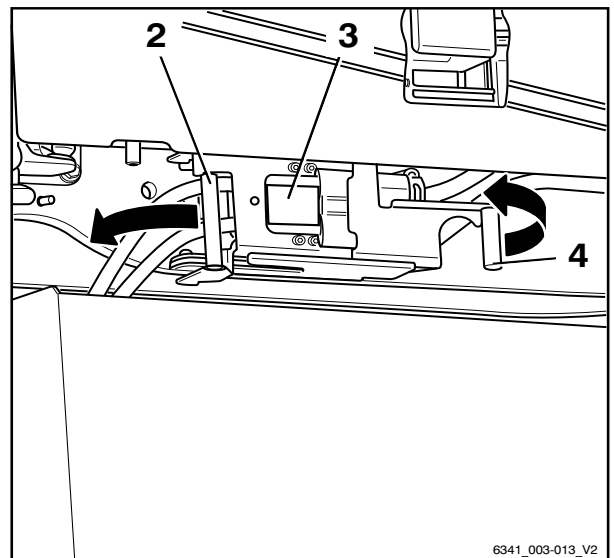

4 Operation

Connecting and disconnecting the battery male connector

- Hang the battery male connector (3) on the front of the battery tray (1).

⚠ CAUTION

When closing the battery cover, there is a risk of damage to the battery male connector!

When you close the battery cover, the battery cover may collide with the battery male connector that you have hung on the battery tray. As a result, the battery male connector may become damaged.

- Leave the battery cover open.

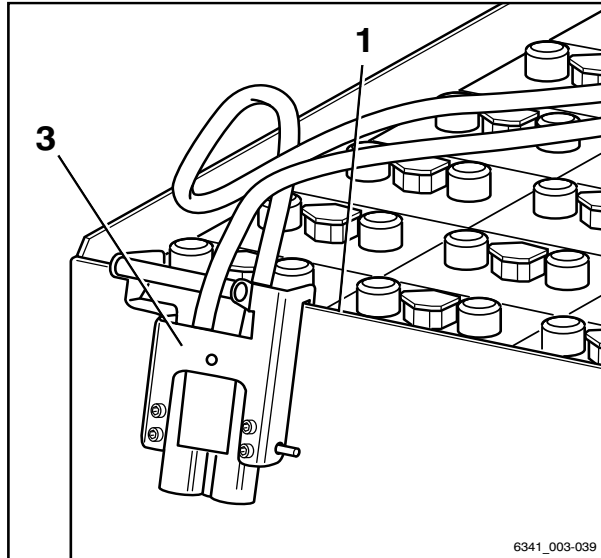

Handling the battery

Safety regulations when handling the battery

Maintenance personnel



⚠ WARNING

Risk of crushing/shearing!

The battery is very heavy. There is a risk of serious injury if limbs are trapped underneath the battery or between the battery cover and the edge of the chassis.

- Wear safety shoes when replacing the battery.
- Only close the battery cover if there is no part of the body between the battery cover and the edge of the chassis.

- The battery must only be replaced in accordance with the directions in these operating instructions.
- When charging and maintaining the battery, observe the manufacturer's maintenance instructions for the battery and the battery charger.

Fire protection measures



⚠ DANGER

Risk of explosion due to flammable gases!

During charging, the battery releases a mixture of oxygen and hydrogen (oxyhydrogen gas). This gas mixture is explosive and must not be ignited.

There must be no flammable materials or spark-forming operating materials within 2 m of either the truck when it is parked for charging or the battery charger.

- Take the following safety precautions.

- Keep away from open flames and do not smoke.
- Always ensure adequate ventilation in the vicinity.

Handling the battery

- Disconnect the battery male connector when the key switch is switched off or the battery charger is switched off.
- Keep the battery cover open during charging.
- Expose the surfaces of the battery cells.
- Do not place any metal objects on the battery.
- Fully open any protective structures (e.g. fabric-covered cab).
- Have fire extinguishing equipment ready.

Lifting accessory

The battery can be removed using the following lifting accessories:

- For trucks, see chapter entitled "Replacing a battery using a truck"

⚠ DANGER

Risk of fatal injury from the battery falling!

The lifting accessory could tip over. The battery could fall off the lifting accessory and onto persons.

The battery must be removed only when the truck is on level, even ground with sufficient load capacity. The load capacity of the lifting accessory in use must at least match the battery weight.

- Ensure the load capacity of the lifting accessory.
- Compare the information on the battery identification plate with the operating instructions or the nameplate.
- Remove the battery on suitable ground.

Battery weight and dimensions

⚠ DANGER

Risk of tipping due to change in battery weight!

The battery weight and dimensions affect the stability of the truck. When replacing the battery, the weight ratios must not be changed. The battery weight must remain within the weight range specified on the nameplate.

- Do not remove or change the position of ballast weights.
- Note the battery weight.

Damage to cables and battery male connectors



⚠ CAUTION

There is a risk of short circuit if the cables are damaged.

- Do not crush the battery cable when closing the battery cover.
- Check the battery cable for damage.

⚠ CAUTION

Risk of damage to the battery male connector when connecting!

If the battery male connector is connected while the key switch is switched on or the battery charger is under load, a jump spark will be produced. The discharge spark can damage the contacts and considerably shorten the service life of the contacts.

- Switch off the key switch or the battery charger.
- Only connect the battery male connector while the key switch is switched off.

⚠ CAUTION

Risk of damage to the battery male connector when disconnecting!

If the battery male connector is disconnected while the key switch is switched on or the battery charger is under load, an arc will be produced. The arc can damage the contacts and considerably shorten the service life of the contacts.

- Switch off the key switch or the battery charger.
- Only disconnect the battery male connector while the key switch or the battery charger is switched off.
- Do not disconnect the battery male connector while under load, except in an emergency.

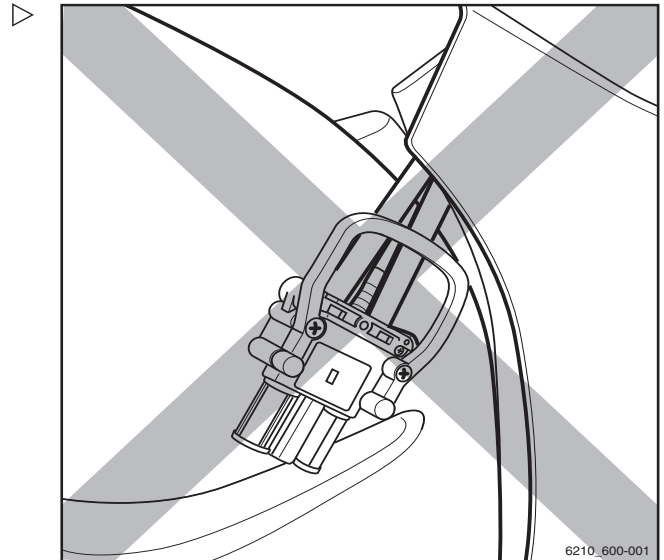

6210_600-001

4 Operation

Handling the battery

Checking the battery charge status

CAUTION

Deep discharges shorten the service life of the battery.

If there are no bars on the battery charge display (1) (0% of the available battery capacity, i.e. around 20% of the nominal capacity), it indicates the start of deep discharge.

- Avoid deep discharge (no bar on the display).
- Cease work with the truck immediately.
- Charge the batteries immediately.
- Do not leave batteries in a discharged or partly discharged state.

- Apply the parking brake.
- Switch on the key switch.
- Read the battery charge (1) on the display.
- Charge a discharged or partly discharged battery.

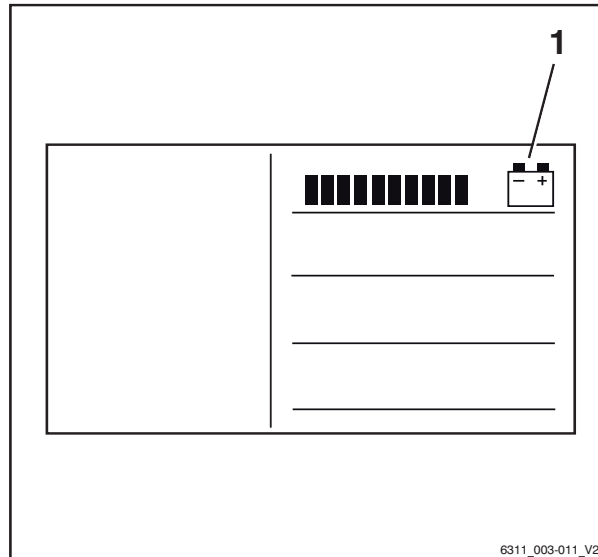

6311_003-011_V2

NOTE

The battery charge displays shows the available battery capacity as a segmented bar graph in 10% increments. Approx. every 10 seconds, the display switches between the battery charge and the remaining operating time.

Charging the battery

DANGER

Risk to life!

- Observe the chapter entitled "Safety regulations for handling the battery" without fail.

WARNING

Battery acid is toxic and corrosive!

- Observe the safety regulations in the "Battery acid" chapter.



⚠ CAUTION

- Risk of component damage!
Incorrect connection or operation of the charging station or battery charger may result in damage to components!
- Follow the operating instructions for the charging station or battery charger and for the battery.

⚠ CAUTION

- Possible damage to the male battery connector!
- Ensure that the key switch or battery charger is switched off before the battery male connector is disconnected or connected.

i NOTE

Battery maintenance is carried out in accordance with the battery manufacturer's operating instructions! The operating instructions for the battery charger must also be followed. Only the instructions that came with the battery charger are valid. If any of these instructions are not available, please request them from the dealer.

i NOTE

A 640-A battery male connector/230-A battery charger plug adaptor cable is available as an accessory from the authorised service centre.

- Park the truck securely.
- Switch off the key switch.
- Always ensure adequate ventilation in the vicinity.
- Open any protective structures fully (e.g. fabric-covered cab).
- Open the battery cover.

4 Operation

Handling the battery

- Open the fastener (4) for the battery male connector (3) by pulling the fastener to the left.
- Disconnect the battery male connector (3) from the plug connection by pulling the handle (2) in the direction of the arrow.
- Do not place any metal objects or tools on the battery.
- Keep away from open flames and do not smoke.
- Inspect the battery cables and charging cables for damage; change if necessary.

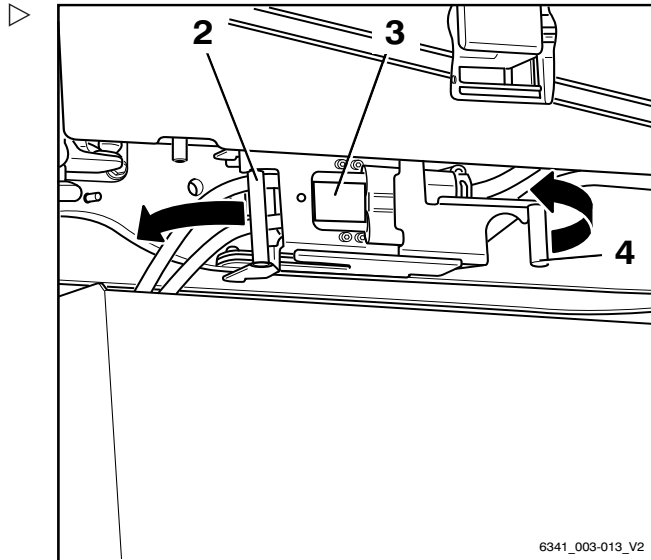

- Use the handle (4) to hang the battery charger plug (5) on the front edge of the battery tray (1).
- Hold the battery male connector (3) by the handle (2) and insert the battery male connector into the battery charger plug (5).
- Push the fastener (6) for the battery charger plug completely to the right to retract the battery male connector into the battery charger plug and to secure the battery male connector in position.

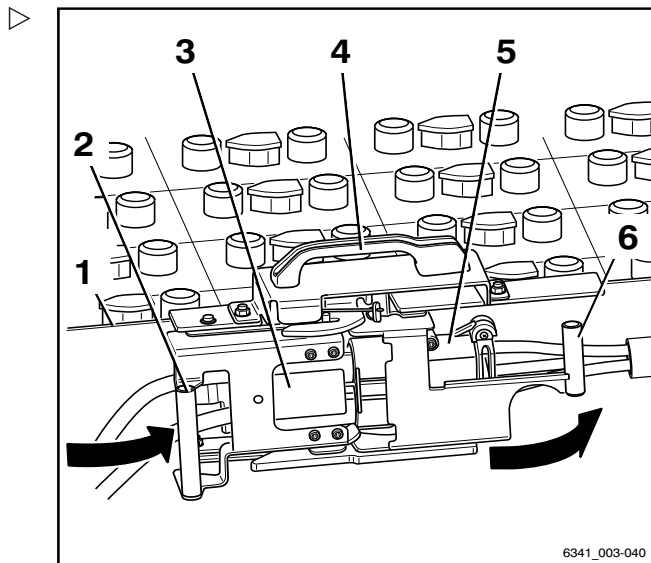

i NOTE

Follow the information in the operating instructions for your battery and the battery charger (equalising charge).

⚠ CAUTION

When using PowerPlusLife® batteries, ensure good circulation of cooling air. The cooling air inlet and cooling air outlet must not be covered. Otherwise, the air cannot circulate through the air ducts and the battery will heat up too much.

- Make sure that no cloths or rags etc. cover the cooling air inlet and cooling air outlet.

- Start the battery charger.

Once the charging process is complete:

- Switch off the battery charger.

Operation

4

Handling the battery

- Open the fastener (6) for the battery charger plug (5) by pulling the fastener to the left. ▷
- Disconnect the battery male connector (3) from the battery charger plug by pulling the handle (2) in the direction of the arrow.
- Pick up the battery charger plug using the handle (4) and remove the battery charger plug from the battery tray (1).

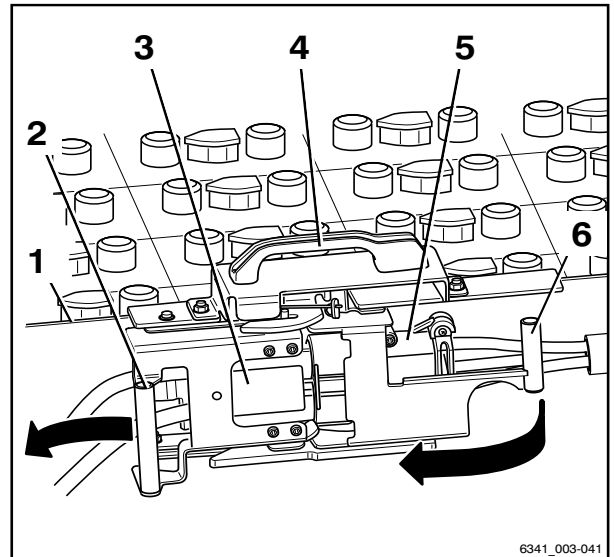

- Hold the battery male connector (2) by the handle (1) and insert the battery male connector into the plug connection on the truck. ▷
- Push the fastener (3) completely to the right to retract the battery male connector into the plug connection and to secure the battery male connector in position.
- Ensure that the battery cable does not come into contact with the battery cover.
- Close the battery cover completely. When doing so, ensure that no cable is crushed between the chassis and the cover.

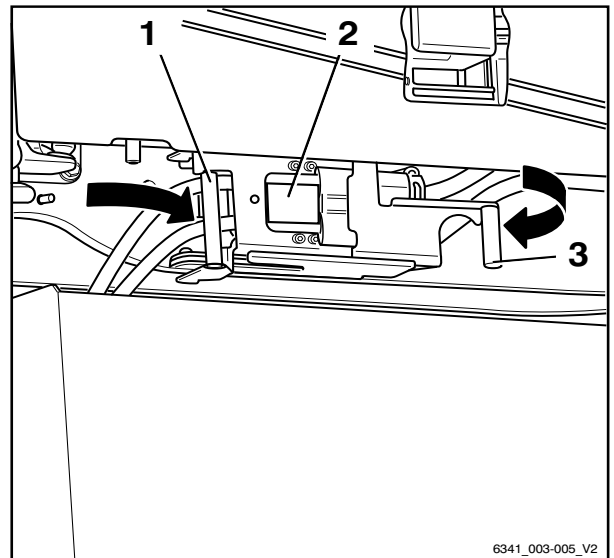

Equalising charging to preserve the battery capacity

Equalising charges ensure that unevenly charged battery cells are evenly charged again. This preserves the service life of the battery and the battery capacity.

An equalising charge should be carried out in accordance with the battery manufacturer's instructions several times a month after the normal charging process.

Handling the battery

NOTE

Depending on the battery charger used, the equalising charge may not begin until 24 hours have elapsed. A period when no shifts are running, such as the weekend, is therefore ideal for performing the equalising charge.

- Observe the information in the operating instructions of the battery charger regarding how to perform an equalising charge.

Starting the equalising charge

- Charge the battery.
- After charging, leave the battery in the charger.

The battery charger remains switched on. Depending on the type of battery charger, the equalising charge begins between 6 and 24 hours after the end of the actual charging process. The equalising charge takes up to 2 hours.

- Please refer to the operating instructions from the manufacturer of the battery charger.

Ending the equalising charge

The equalising charge ends automatically. If the battery is required during this process, you can interrupt the equalising charge by pushing the "stop button" on the battery charger.

- Please refer to the operating instructions from the manufacturer of the battery charger.

CAUTION

Damage to the connection assembly is possible!

If you disconnect the charging cable while the battery charger is switched on, an arc will be produced. This can lead to erosion at the contacts, which considerably shortens the service life of the contacts.

- Switch off the battery charger before you disconnect the charging cable.
- Switch off the battery charger.
- Disconnect the battery male connector from the plug for the battery charger.

- Insert the battery male connector fully into the plug connection on the truck.

Replacing and transporting the battery

General information on replacing the battery

⚠ CAUTION

Risk of components being damaged by the lifting accessory and battery rolling away!

The lifting accessory and battery may roll away in an uncontrolled manner if the battery is not replaced on a level, even floor with sufficient load capacity.

- Observe the operating instructions for the lifting accessory used.
- Always replace the battery on a level, even floor with sufficient load capacity.

Use the following lifting accessories when replacing the battery:

- Truck
- ECU 30 special pallet truck

The load capacity of the lifting accessory used must at least match the battery weight (see battery identification plate).

Changing to a different battery type

It is generally possible for a truck to be converted to a different battery type and a different capacity by the authorised service centre.

Note the following points:

- The display-operating unit must be adjusted to the new battery capacity.

If this is not done, the actual battery discharge status cannot be determined. The battery charge level is not displayed correctly.

In the worst case, the battery may be damaged by a deep discharge.

- Contact your authorised service centre.

Replacing and transporting the battery

i NOTE

When converting to PowerPlusLife® batteries, the maximum speed of the truck can be increased to 20 km/h.

- Contact your authorised service centre.

i NOTE

When converting from PowerPlusLife® batteries to other batteries, the maximum speed of the truck must be limited to 17 km/h for technical reasons.

- Contact your authorised service centre.

Opening and closing the battery cover

Opening the battery cover

⚠ WARNING

Risk of injury from the battery cover lowering!

The battery cover (1) is equipped with gas springs that hold it in the opened position. When additional load is present, for example through heavy objects, strong wind or other persons, the battery cover can lower suddenly. Cold weather and ageing can also reduce the performance of the gas springs and cause the cover to lower.

- Make sure that the battery cover is not being pushed down by strong winds or other persons.
- If the gas springs no longer hold the battery cover independently, notify your authorised service centre.

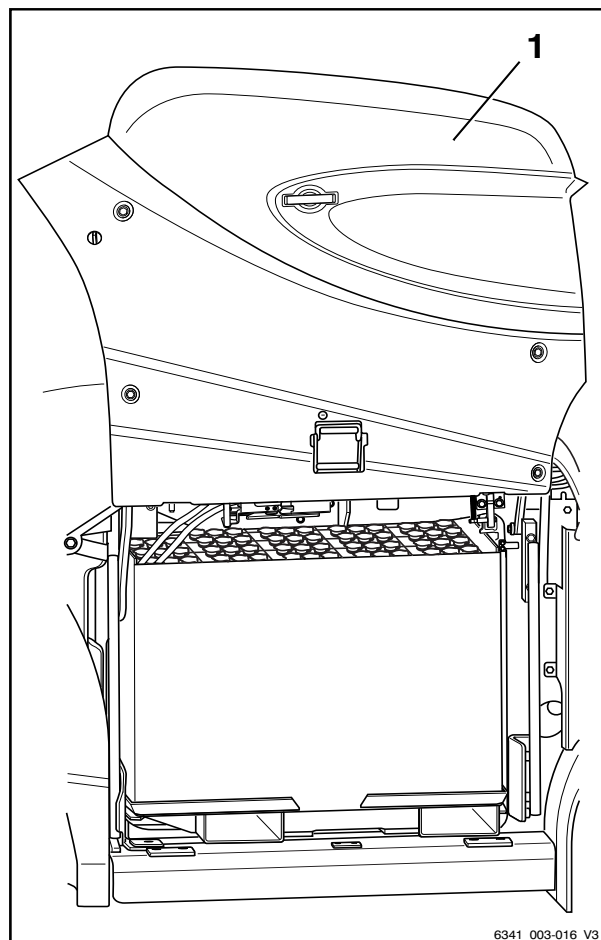

6341_003-016_V3

Operation

4

Replacing and transporting the battery

- Unlock the quick release clamp (1) with a 1/4 turn in a clockwise direction.
- Open the battery cover lock (3) using the key.
- To release the battery cover, pull the handle (4) and at the same time use the other handle (2) to swivel the battery cover upwards.

NOTE

Beneath the battery cover, there is a latch that engages in the upper position of the battery cover and prevents accidental closing.

- Make sure that the safety hook (1) engages in the gap on the bracket (2).

Closing the battery cover

CAUTION

When closing the battery cover, limbs could become trapped — risk of crushing!

When closing the battery cover, nothing should come between the battery cover and the edge of the chassis.

- Do not grasp any edges. Always close the battery cover by grasping one of the handles in each hand.
- Close the battery cover carefully.
- Only close the battery cover if there are no parts of the body in the way.

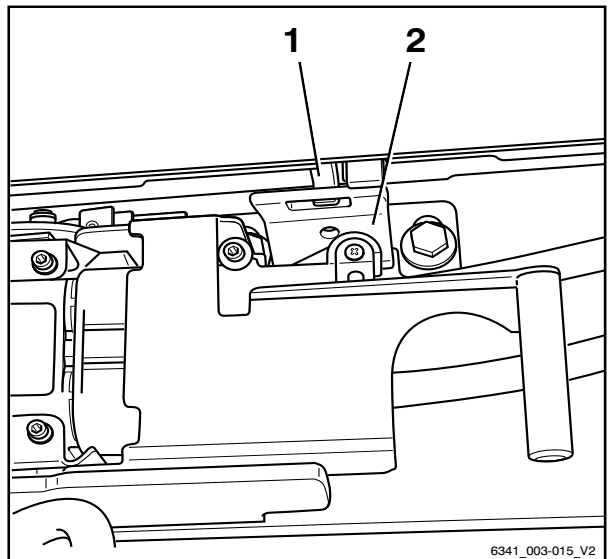
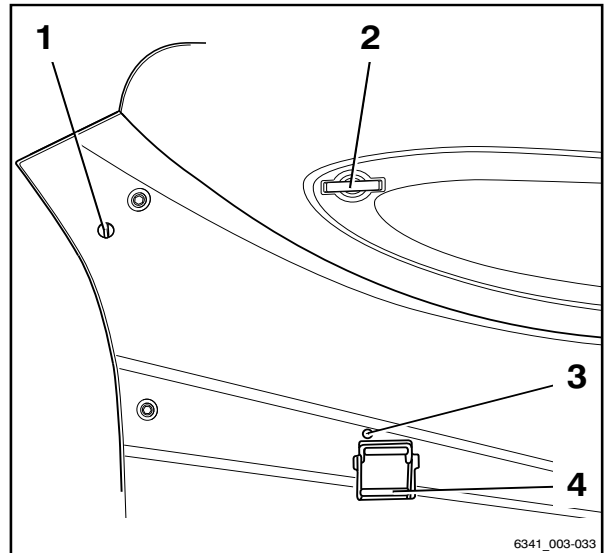

4 Operation

Replacing and transporting the battery

- To close the battery cover, take hold of the handles (2) and (4) at the same time and pull down firmly.
- Make sure that the battery cover lock engages when you close it.
- Lock the battery cover lock (3) using the key.
- Lock the quick release clamp (1) with a 1/4 turn in an anti-clockwise direction.

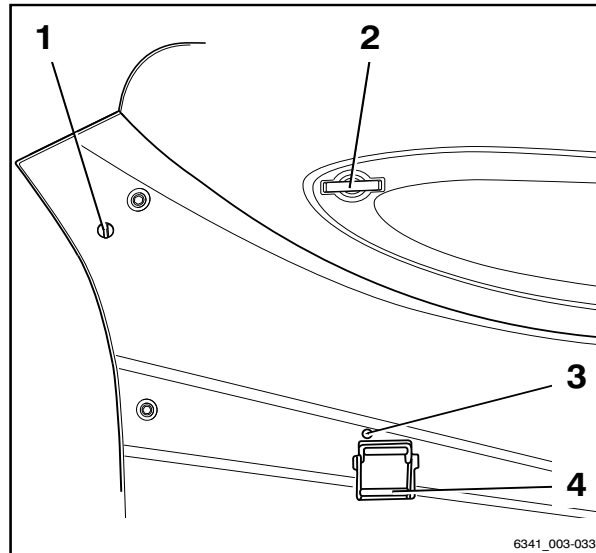

i NOTE

The battery cover is only correctly locked if the top section of the handle (4) closes flush with the cover.

Replacing the battery

⚠ DANGER

Risk to life!

- Observe the chapter entitled "Safety regulations for handling the battery" without fail.

i NOTE

The battery can be replaced using the following lifting accessories. Observe the relevant operating instructions.

- Truck
- ECU 30 special pallet truck

Preparation

The load capacity of the lifting accessory in use must at least match the battery weight (see battery identification plate).

The procedure for replacing a battery does not differ depending on the lifting accessory selected.

- Check the load capacity of the lifting accessory.
- Make sure that the floor is suitable for battery removal.
- Switch off the key switch.

Operation

4

Replacing and transporting the battery

- Open the battery cover.

⚠ CAUTION

Do not disconnect the battery male connector while the key switch is switched on!

- Ensure that the key switch is switched off.

- Open the fastener (4) for the battery male connector (3) by pulling the fastener to the left.

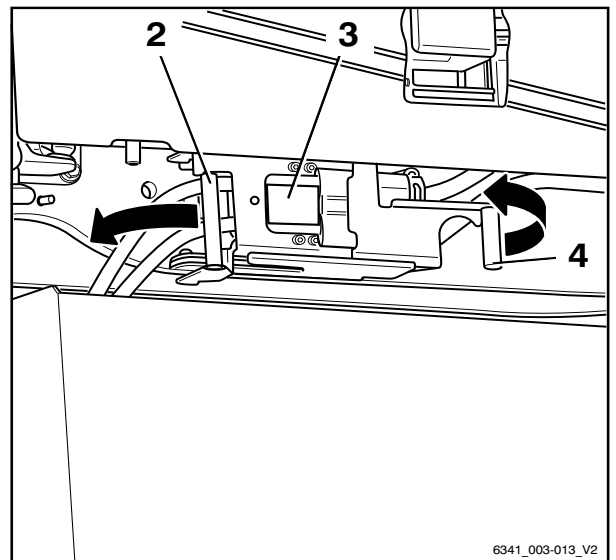

- Disconnect the battery male connector (3) from the plug connection by pulling the handle (2) in the direction of the arrow.

- Check the battery cable for damage.

- Hang the battery male connector (3) on the front edge of the battery tray (1).

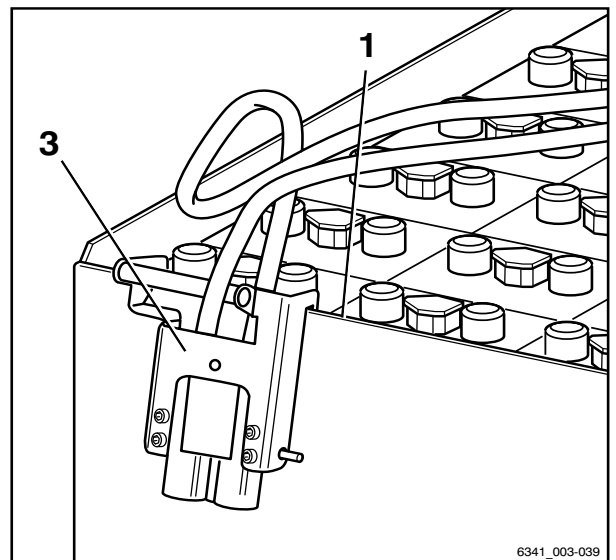

- When removing the battery cable, make sure that it does not come into contact with any components.

4 Operation

Replacing and transporting the battery

- Adjust the distance (A) between the fork arms of the lifting accessory to match the distance (A) between the forked fittings in the battery base frame.
- Swivel the battery lock (1) upwards.

The battery lock is held in the raised position by means of the tension spring. The battery can be accessed as required.

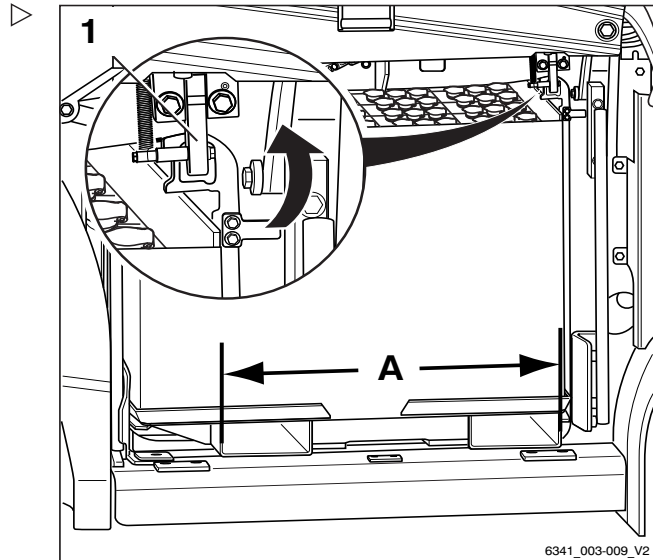

Taking up the battery



⚠ WARNING

Risk of crushing/shearing!
Personnel must not stand directly next to the battery or between the battery and the truck when removing and inserting the battery with the truck.

- Determine the length of the battery base frame and, starting from the fork tip, mark one of the fork arms; dimension (B).
- Move the fork arms carefully up to the mark in the forked fittings in the battery base frame.
- Carefully lift the battery and battery base frame up and out of the truck. When doing so, pay attention to the distance to the chassis.
- Carefully remove the battery and the battery base frame from the truck, i.e. at a low speed, using slow steering movements and braking carefully.

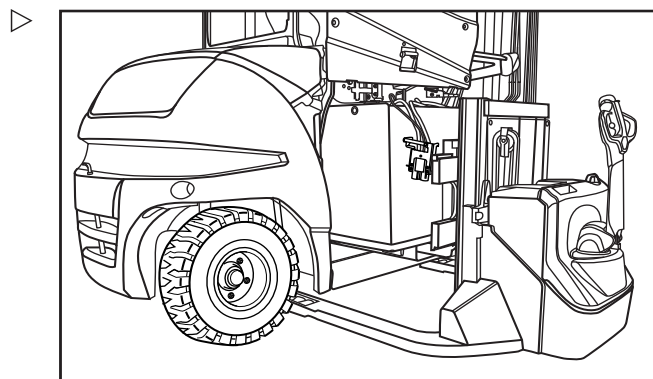
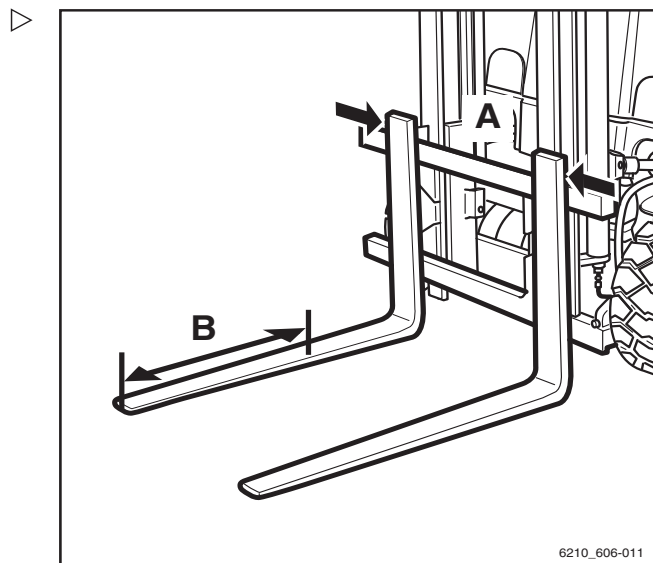

Operation

4

Replacing and transporting the battery

- Set the battery and battery base frame down carefully. ▷

The battery always remains on the battery base frame.

Installing the battery

⚠ CAUTION

Damage to the battery possible!

If the battery is not used in the truck in conjunction with the battery base frame, the battery cannot be securely positioned in the battery compartment. The battery can tip over in the battery compartment. This may cause damage to the battery and the truck components.

- Always use the battery in conjunction with the battery base frame.
- Pick up the new battery along with the battery base frame and carefully transport it to the truck.
- Make sure to hang the battery male connector (3) on the front edge of the battery tray (1), and ensure that the battery cable does not become trapped during installation. ▷
- Position the battery at a right angle to the truck.

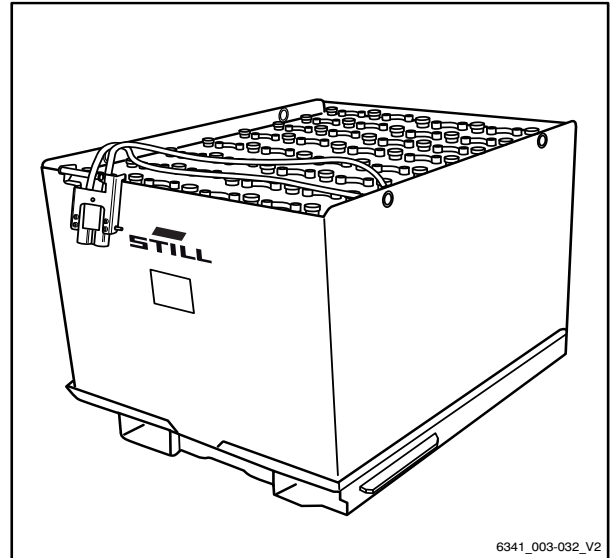

6341_003-032_V2

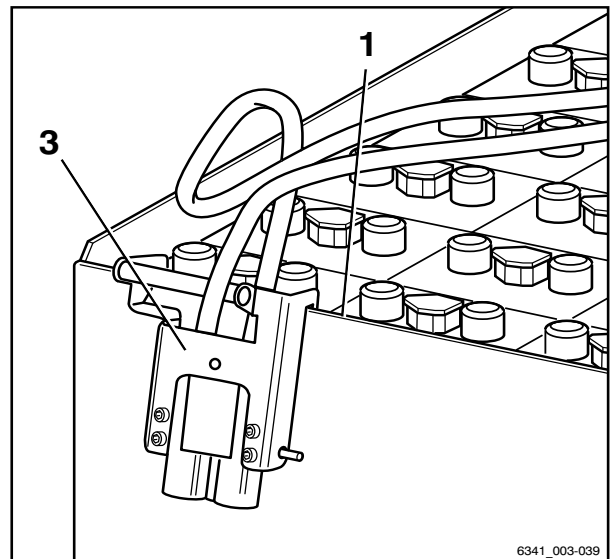

6341_003-039

4 Operation

Replacing and transporting the battery

The slide rail (1) serves as an installation aid and guides the battery base frame at a right angle into the battery compartment.

The impact protection (2) protects the flap support from damage during insertion of the battery.

The detent cams (3) must engage in the battery base frame when the battery is lowered. When the detent cams are engaged, the battery is prevented from slipping sideways out of the battery compartment.

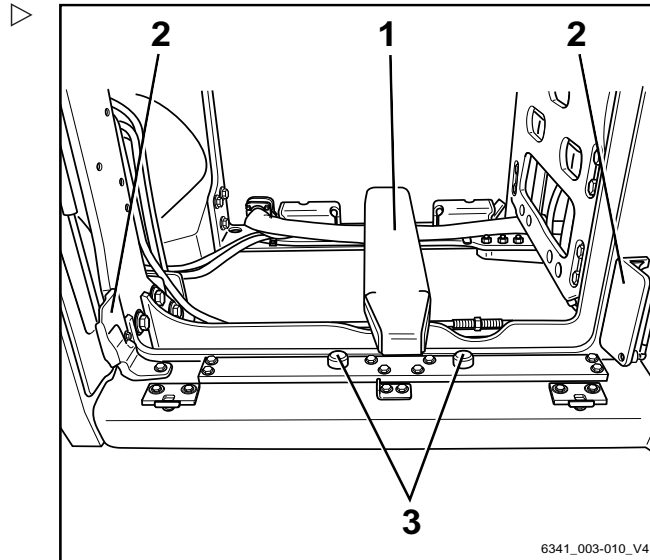

- Carefully insert the battery into the battery compartment. When doing so, take note of the adjustment and entry aids (3) on the left of the battery compartment.

i NOTE

The battery must be guided in flush against the adjustment and entry aids (3). This will help the driver to insert the battery without it getting stuck on the truck.

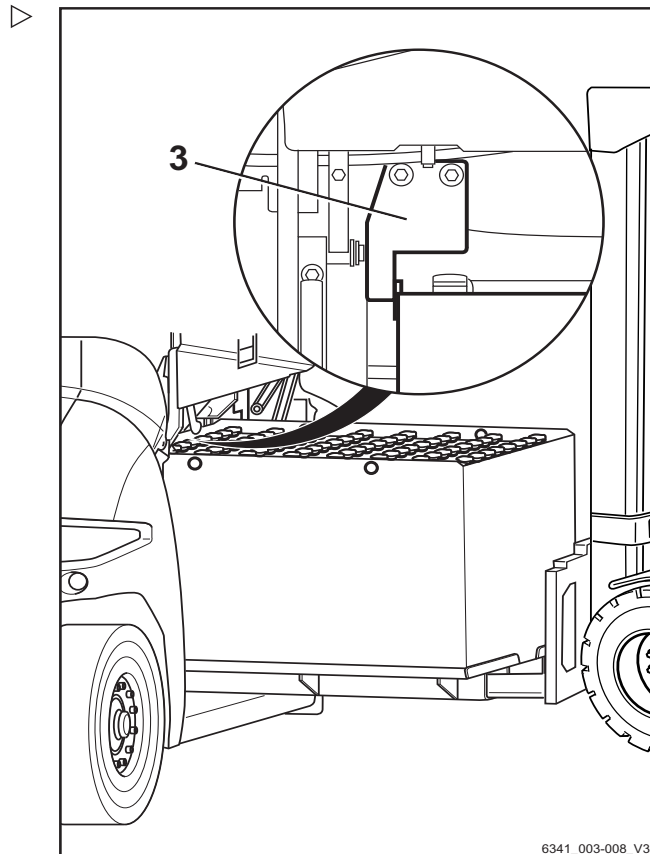

Operation

4

Replacing and transporting the battery

Once the battery is positioned correctly in the battery compartment: ▷

- Carefully lower the battery.
- Check that the detent cams (2) are fully engaged in the bores (1) and that the battery is level.
- If the battery is not positioned correctly, repeat this process.
- Carefully move the fork arms out from the battery base frame.

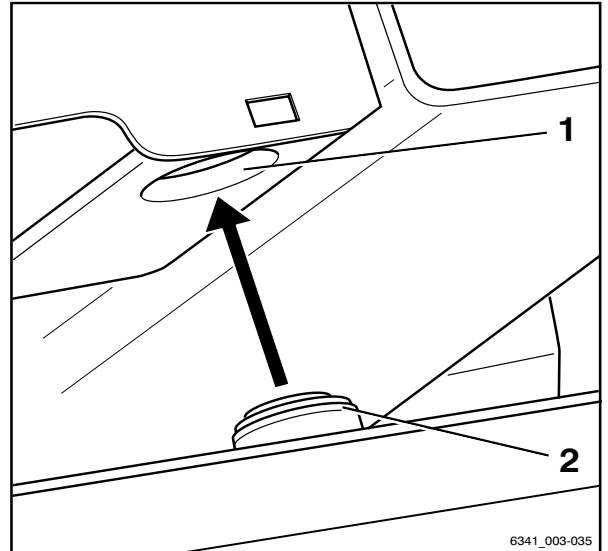

- Swivel the battery lock (1) downwards. ▷

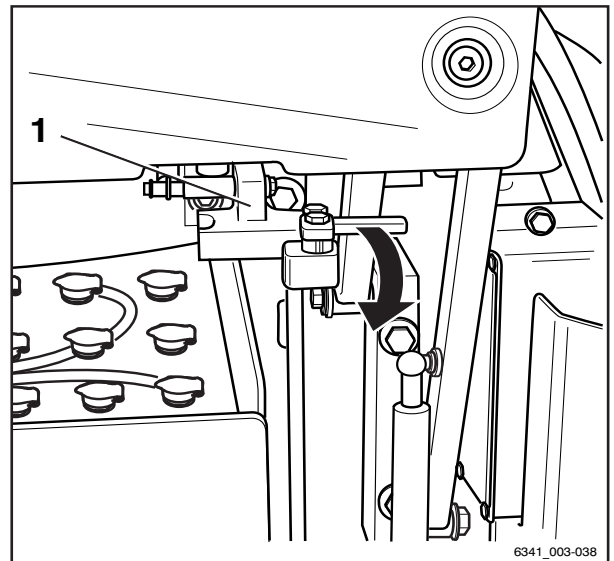

4

Operation

PowerPlusLife battery

- Hold the battery male connector (2) by the handle (1) and insert the battery male connector into the plug connection on the truck.
- Push the fastener (3) completely to the right to retract the battery male connector into the plug connection and to secure the battery male connector in position.
- Ensure that the battery cable cannot come into contact with the battery cover.
- Close the battery cover.

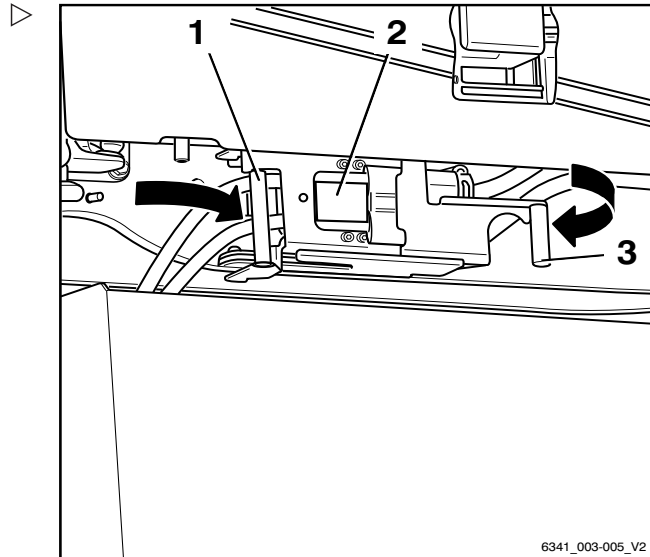

PowerPlusLife battery

PowerPlusLife® battery

The PowerPlusLife® battery is an air-cooled lead-acid battery. The self-cooling feature gives this battery significant advantages over conventional lead-acid batteries which heat up during operation and whilst charging, and stay hot for a long time.

The PowerPlusLife® battery is a protected in-house development by STILL GmbH.

Advantages of the PowerPlusLife® battery:

- Higher driving speeds and greater handling performance
- Longer battery life, even under severe conditions
- Continuous temperature-controlled self-cooling, even when removed from the truck and not connected to a battery charger
- Ready for use again more quickly after charging
- Less heat radiated into the driver's compartment

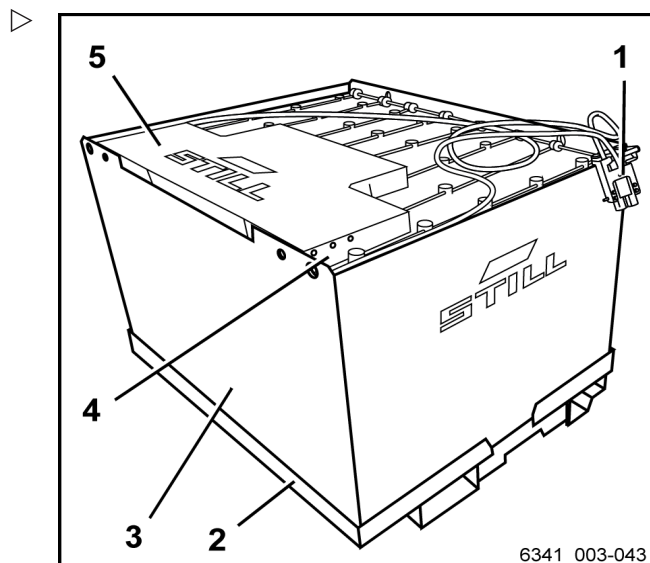

- 1 Battery male connector
- 2 Battery tray
- 3 Battery rack
- 4 Temperature monitoring
- 5 Battery management

i NOTE

When converting to PowerPlusLife® batteries, the maximum speed of the truck can be increased to 20 km/h.

- *Contact your authorised service centre.*

Cooling air flow

⚠ CAUTION

If the cooling air flow is low, the cooling of the battery malfunctions.

Do not cover the intake openings (1) and air distributors (2) on the battery. Otherwise, the cooling air flow cannot circulate through the air ducts. The battery will then heat up too much.

- Make sure that the intake openings and air distributors stay open.
- When installing and removing the battery, check the intake openings and air distributors for dirt.

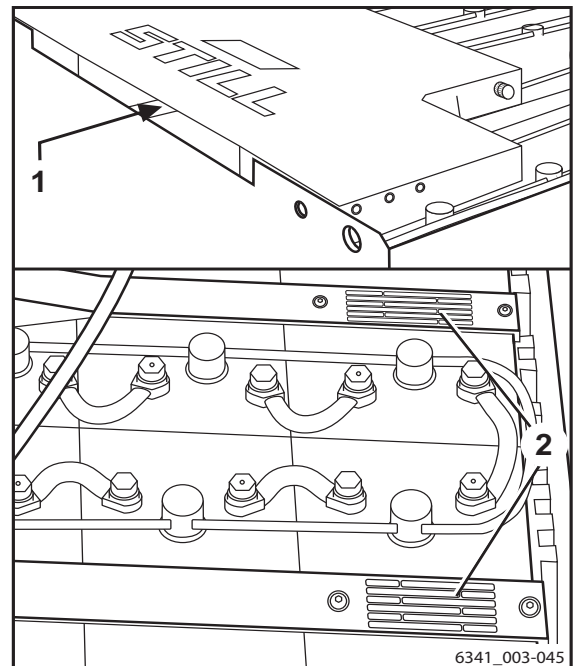

- 1 Intake opening
- 2 Air distributors

PowerPlusLife battery

PowerPlusLife® temperature monitoring

The control unit detects the core temperature of the battery and adjusts the fan control for cooling. The LEDs continuously indicate the cooling state of the battery.

If the red LED (1) is illuminated, the battery temperature is high and cooling is active.

If the yellow LED (2) is illuminated, battery cooling is active.

If the green LED (3) is illuminated, the battery is ready for use.

Especially when PowerPlusLife® batteries are used for mixed applications, the temperature monitoring function makes it clear whether the battery has cooled down sufficiently after charging and is now ready for use.

- If the red LED (1) is illuminated, allow the battery to cool down further until the red LED goes out.

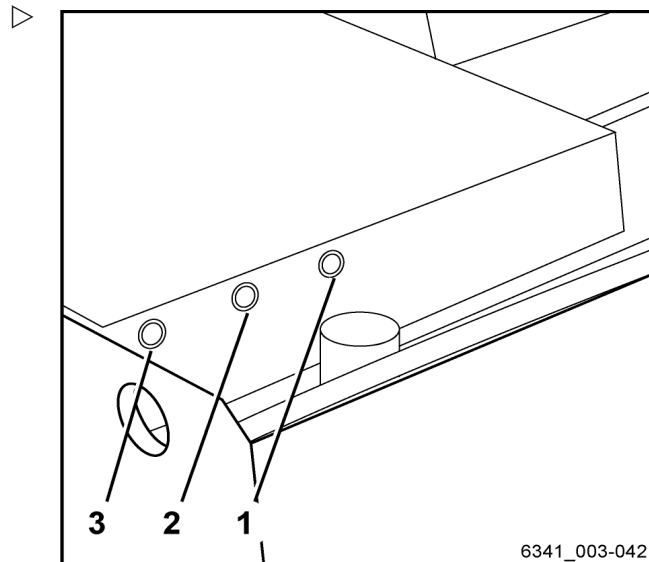

- | | |
|---|-----------------------------|
| 1 | Red LED "not ready for use" |
| 2 | Yellow LED "cooling active" |
| 3 | Green LED "ready for use" |

PowerPlusLife® error messages

One of the three LEDs is always lit up to indicate the cooling status of the PowerPlusLife® battery. If an LED changes from being permanently illuminated to flashing, it indicates that an error message has been generated. The error message is independent of the colour of the LED. In the event of a fault, it is always the LED that is currently illuminated that flashes.

The following error messages are indicated by a flashing LED:

Fluid level

The fluid level in the PowerPlusLife® battery is checked by a sensor.

If an LED slowly flashes alternately, it indicates that the fluid level is too low.

- Top up the fluid; see the chapter entitled "Servicing the battery".

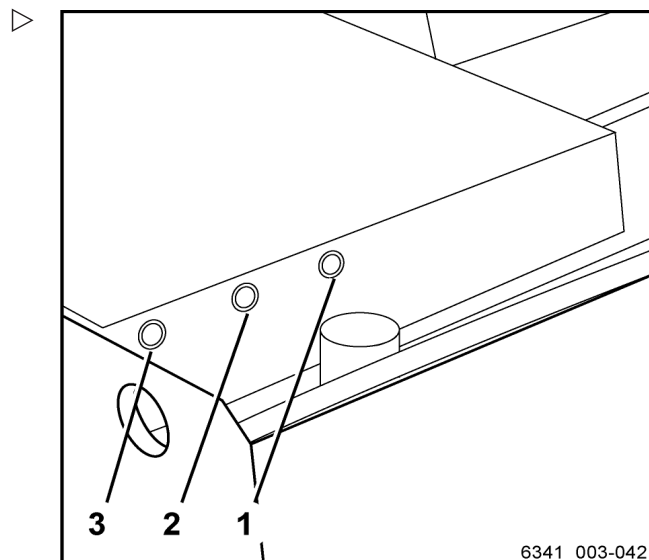

- | | |
|---|------------|
| 1 | Red LED |
| 2 | Yellow LED |
| 3 | Green LED |

Internal error

If an LED flashes at frequent intervals, it indicates the presence of an internal fault.

The error can be read using the diagnostics function. The diagnostic connector (1) is located on the battery management device, on the right alongside the LEDs.

- Contact your authorised service centre.

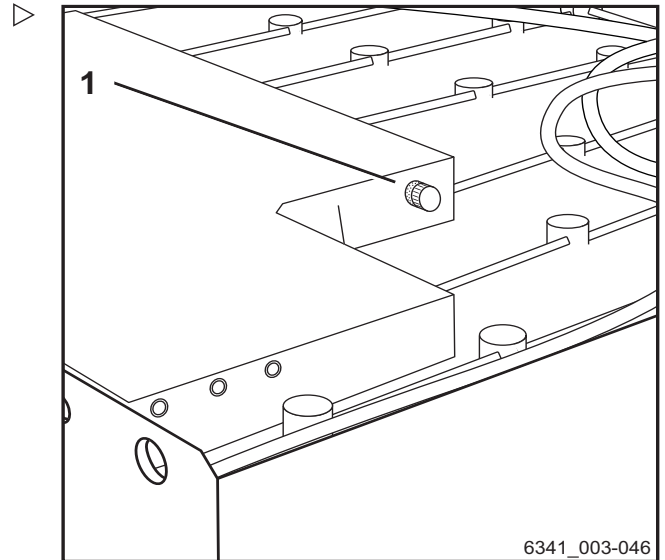

6341_003-046

1 Diagnostic connector

Cleaning

Cleaning

Cleaning the truck



⚠ WARNING

Risk of injury from falling off the truck!

When climbing onto the truck, there is a risk of getting stuck or slipping and falling. Use suitable equipment to reach higher points on the truck.

- Use only the steps provided to climb onto the truck.
- Use equipment such as stepladders or platforms to reach inaccessible areas.



⚠ WARNING

Risk of fire due to flammable cleaning materials!

Flammable cleaning materials can be ignited by hot components.

- Do not use any flammable cleaning materials.



⚠ CAUTION

Risk of fire due to flammable materials!

Deposits and solids can be ignited by hot components, e.g. drive units.

- Remove deposits and solids.

⚠ CAUTION

Risk of damage to the battery male connector when disconnecting!

If the battery male connector is disconnected while the key switch is switched on under load, an arc will be produced. The arc can damage the contacts and considerably shorten the service life of the contacts.

- Switch off the key switch.
- Only disconnect the battery male connector while the key switch is switched off.

⚠ CAUTION

If water penetrates the electrical system, there is a risk of short circuit!

- Adhere strictly to the following steps.



⚠ CAUTION

Excessive water pressure or water and steam that are too hot can damage truck components.

- Adhere strictly to the following steps.

⚠ CAUTION

Abrasive cleaning materials can damage the surfaces of components!

Using abrasive cleaning materials that are unsuitable for plastics can cause plastic parts to dissolve or become brittle. The screen on the display-operating unit could become cloudy.

- Adhere strictly to the following steps.
- Park the truck safely.
- Switch off the key switch.
- Disconnect the battery male connector.
- Do not spray electric motors and other electrical components or their covers directly with water.
- Use only high-pressure cleaners with a maximum output power of up to 50 bar and 85°C.
- If a high-pressure cleaner is used, maintain a distance of at least 20 cm between the nozzle and the object being cleaned.
- Do not aim the cleaning jet directly at adhesive labels or decal information.
- Remove all deposits and accumulations of foreign materials in the vicinity of hot components.
- Use only non-flammable fluids for cleaning.
- Note the manufacturer's guidelines for working with cleaning materials.
- Clean plastics only with cleaning materials intended for plastics.
- Note the manufacturer's guidelines for working with cleaning materials.
- Clean the truck exterior using water-soluble cleaning materials and water. Cleaning with a water jet, a sponge or a cloth is recommended.
- Clean all accessible areas.

4

Operation

Cleaning

- Before lubrication, clean the oil filling openings and the area around the oil filling openings, as well as the lubricating nipples.

Cleaning the electrical system

⚠ WARNING

Danger of electric shocks due to residual capacity!

- Never reach into the electrical system with your bare hands.



⚠ CAUTION

Cleaning electrical system parts with water can damage the electrical system.

Cleaning electrical system parts with water is forbidden!

- Do not remove covers etc.
- Use only dry cleaning materials in accordance with the manufacturer's specifications.

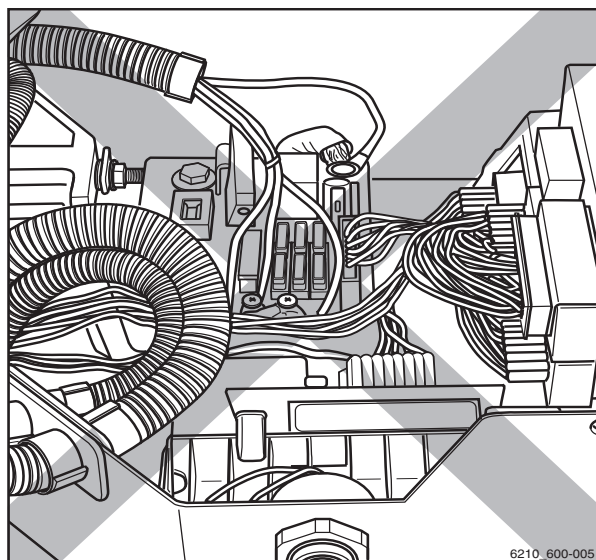

- Clean the electrical system parts with a metal-free brush and blow the dust off with low-pressure compressed air.

Cleaning load chains

⚠ WARNING

Risk of accident!

Load chains are safety elements.

The use of cold/chemical cleaners or fluids that are corrosive or contain acid or chlorine can damage the chains and is forbidden!

- Observe the manufacturer's guidelines for working with cleaning materials.
- Place a collection vessel under the lift mast.
- Clean with paraffin derivatives, such as benzine.
- When using a steam jet, do not use additional cleaning agents.
- Remove any water in the chain links using compressed air immediately after cleaning.

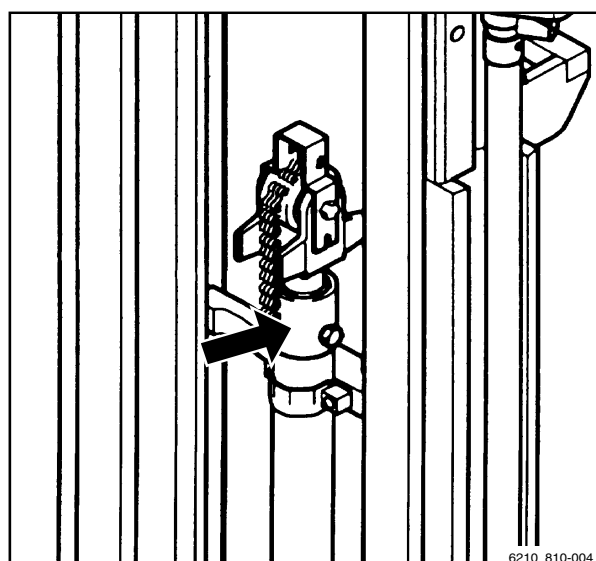

Move the chain several times during this procedure.

- Immediately after drying the chain, spray it with chain spray. Move the chain several times during this procedure.

For chain spray specifications, see the "Maintenance data table" chapter.



ENVIRONMENT NOTE

Dispose of any fluid that has been spilled or collected in the collection vessel in an environmentally friendly manner. Follow the statutory regulations.

Cleaning the windows

Any panes of glass, e.g. cab windows (variant), must always be kept clean and free of ice. This is the only means of guaranteeing good visibility.

⚠ CAUTION

Do not damage the rear window heater (inside)!

- Take great care when cleaning the rear window and do not use any objects with sharp edges.
- Clean the windows using a commercially available glass cleaner.

After cleaning

⚠ CAUTION

Danger of short-circuits!

Ingress of moisture into the battery male connector can lead to an electrical short circuit.

- Use compressed air to dry the battery male connector before you connect the battery male connector.
- Only connect the battery male connector if it is dry.
- Thoroughly dry the truck after wet cleaning, e.g. using compressed air.
- Apply a thin layer of oil or grease to all uncoated moving parts.



4 Operation

Cleaning

- Grease the truck.
- Lubricate the joints and controls.
- Lubricate the battery cover interlock.
- Check that the battery male connector is dry before you connect the battery male connector.

NOTE

The more often the truck is cleaned, the more frequently the truck must be lubricated.

Procedure in emergencies

Emergency shutdown

⚠ WARNING

Electrical and hydraulic functions will no longer be available following an emergency shutdown!

The emergency shutdown procedure disables the hydraulic functions. The entire electrical system is de-energised.

- Only use this safety system in the event of an emergency.

In drive mode, the emergency shutdown has the following effect:

- Regenerative braking is not available.
- The regenerative brake will not hold the truck on ascending or descending gradients. Actuate the service brake, otherwise the truck will roll down gradients.
- No speed reduction when you release the accelerator pedal. The truck will coast.
- Power steering is not available. Steering forces are increased by the remaining emergency steering function.
- The "Curve Speed Control" system (automatic reduction of speed when cornering) is not available.
- Hydraulic functions are not available.

In the event of an emergency, all electrical and hydraulic functions can be switched off via the emergency off switch or via the battery male connector using the following procedures:

4

Operation

Procedure in emergencies

Emergency shutdown via the emergency off switch ▷

- Push the emergency off switch (1).
- Steer the truck to a safe place by applying greater steering power.
- Decelerate the truck with the service brake by depressing the brake pedal.
- Use the service brake to hold the truck on ascending or descending gradients.

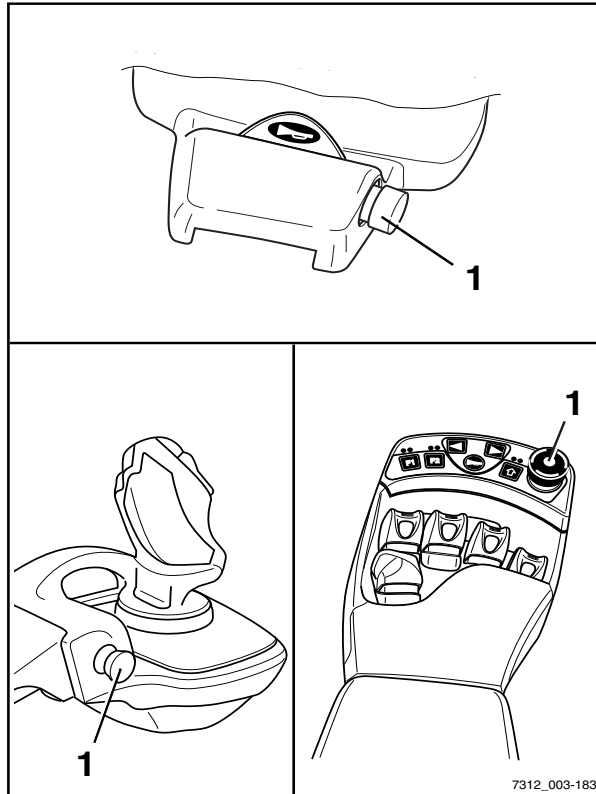

Emergency shutdown via the battery male connector ▷

⚠ CAUTION

Risk of damage to the battery male connector when disconnecting!

If the battery male connector is disconnected while the key switch is switched on under load, an arc will be produced. The arc can damage the contacts and considerably shorten the service life of the contacts.

- Do not disconnect the battery male connector while under load, except in an emergency.
- Pull the fastener (4) to the left and open the fastener.
- Disconnect the battery male connector (3) from the plug connection by pulling the handle (2) in the direction of the arrow.

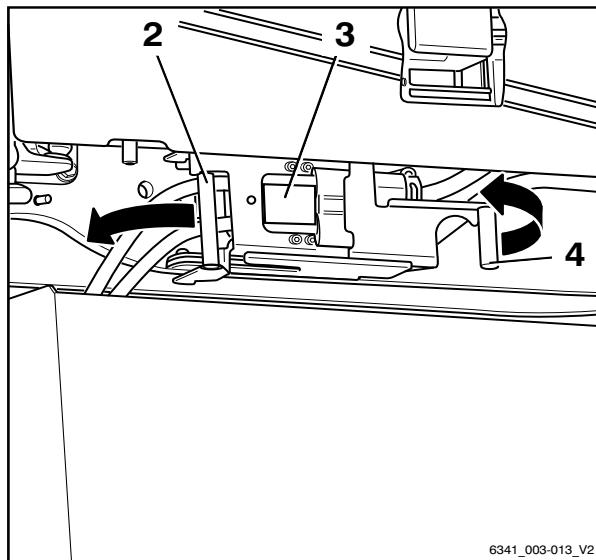

i NOTE

An emergency shutdown via the battery male connector can be performed only when the truck is stationary and the battery cover is open.

Procedure if truck tips over

⚠ DANGER

If the truck tips over, the driver could fall out and slide under the truck with potentially fatal consequences. There is a risk to life.

Failure to comply with the limits specified in these operating instructions, e.g. driving on unacceptably steep gradients or failing to adjust speed when cornering, can cause the truck to tip over. If the truck starts to tip over, do not leave the truck under any circumstances. This increases the danger of being hit by the truck.

- Do not release your seat belt.
- Never jump off the truck.
- You must adhere to the rules of behaviour if the truck tips over.

Rules of behaviour if truck tips over:

- Hold onto the steering wheel with your hands.
- Brace your feet in the footwell.
- Bend your upper body over the steering wheel.
- Bend your body against the direction of the fall.

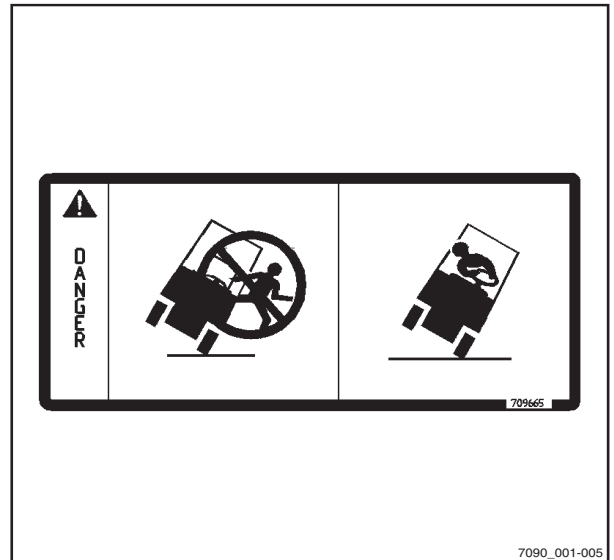

Procedure in emergencies

Emergency hammer

The emergency hammer is used to rescue the driver if he is shut inside the cab in a hazardous situation, for example if the truck has toppled over and the cab door cannot be opened.

Single-pane safety glass can be struck relatively safely using the emergency hammer in order for the driver to escape or be rescued from the danger area.

Using the emergency hammer

WARNING

When glass is smashed there is a risk of injury caused by glass splinters!

When the cab glass is smashed, splinters of glass can shoot into the face and cause damage to skin and eyes through cuts. When a pane of glass is smashed, the face should be turned away and covered with the crook of the free arm.

- Protect the face when smashing a pane of glass.
- Pull the emergency hammer out of its support mounting at the handle.
- Using one of the two metal tips on the head of the emergency hammer, hit the pane of glass with force until it breaks.

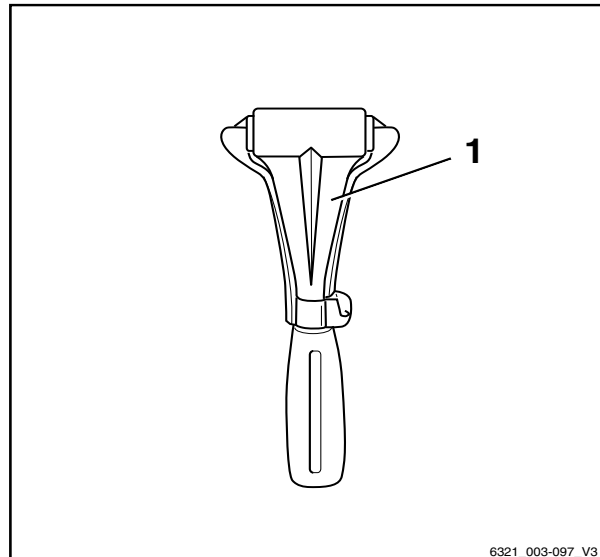

Emergency lowering

If the hydraulic controller fails whilst a load is raised, emergency lowering can be performed. An emergency lowering screw for this purpose is located on the control block.



DANGER

There is a risk of fatal injury from falling loads or parts of the truck being lowered.

- Do not walk beneath the raised load.
- Follow the steps described below.

NOTE

A hexagon socket wrench is located beneath the bottom plate on the brake valve for carrying out the steps detailed below. This hexagon

Operation

4

Procedure in emergencies

socket wrench must remain in the truck at all times.

- Remove the bottom plate.
- Take the hexagon socket wrench (1) out of the support mounting. ▷
- Open the front right cover.

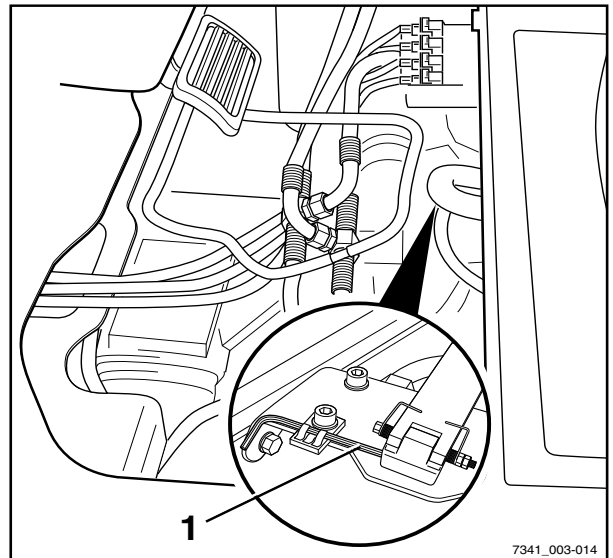

- Loosen the emergency lowering screw (3) on the control block (2) by a maximum of 1.5 revolutions using the hexagon socket wrench. ▷
- Screw the emergency lowering screw back in after the load is lowered.
- Return the hexagon socket wrench to the support mounting provided.
- Install the bottom plate.
- Close the front right cover.

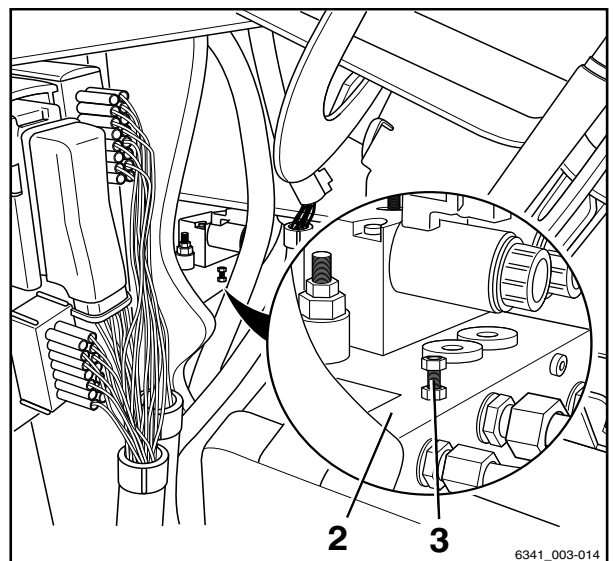

⚠ WARNING

The load is lowered!

The lowering speed is regulated by unscrewing the emergency lowering screw.

- Note the following list.

Remember the following:

- Tightening torque:
max. 2.5 Nm
- When unscrewed a little:
The load lowers slowly
- When unscrewed a lot:
The load lowers quickly

Procedure in emergencies

⚠ DANGER

If the truck is operated with the hydraulic controller blocked, there is an increased risk of accidents!

- After the emergency lowering procedure, have the malfunction rectified.
- Notify the authorised service centre.

Releasing the spring-operated brake

⚠ CAUTION

Component damage as a result of blocked brakes!

In order to tow the truck, the multi-disc brakes must not be blocked in the drive wheel units.

- Repeatedly release the spring-operated brake during the towing process, in accordance with the table below.

The truck is equipped with a negative spring-operated brake. Switching off the truck will block the multi-disc brakes in the drive wheel units after a few minutes. However, the truck can still be moved until the drive wheel units are blocked. In order to tow the truck, the spring-operated brake must be released by actuating the brake valve. Otherwise, the truck is towed with the wheels blocked.

i NOTE

The brake valve is installed in front of the driver's seat beneath the bottom plate.

The coupling pin from the counterweight can be used as an aid to actuate the brake valve. If there is no removable coupling pin available on the truck, for example, if the truck is equipped with an automatic tow coupling (variant), the bottom plate must be raised completely in order to access the brake valve.

Once the spring-operated brake is released, the pressure gradually drops again in the brake hydraulics and the brakes can block again. The towing process must be interrupted at certain times and the spring-operated brake released again, in accordance with the table below.

Operation

4

Procedure in emergencies

Hydraulic oil temperature	Period after releasing the spring-operated brake until it is blocked once again	
	Minutes	Seconds
-20 °C	190	0
20	7	40
50	2	50
95	1	50

Actuate the brake valve by means of a coupling pin:

- Take the coupling pin out of the counter-weight.
- Grip the rubber tab in the rubber mat using the finger opening and pull up the tab.

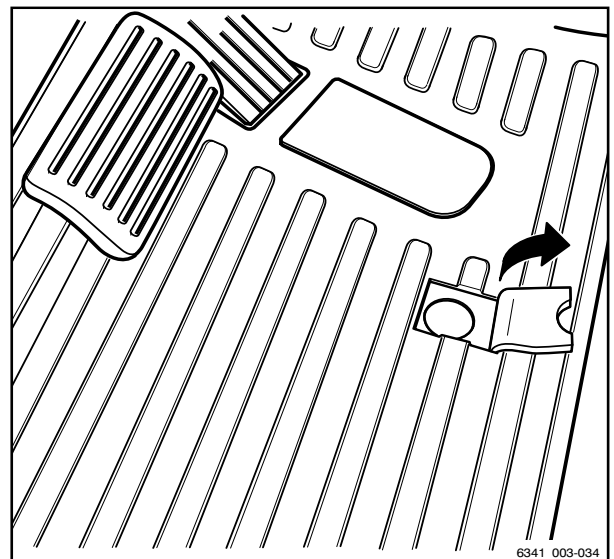

4 Operation

Procedure in emergencies

- Insert the coupling pin (1) into the bore (2) on the bottom plate until the pin noticeably rests on the brake valve plate beneath.
- Repeatedly press the coupling pin down vertically.

The spring-operated brake is released.

i NOTE

To fully release the spring-operated brake, press down on the brake valve plate at least 30 times. The pressure that builds up in the brake hydraulics as a result releases the spring-operated brake.

- Once the spring-operated brake is released, fold the rubber tab in the rubber mat back down.
- Insert the coupling pin in the counterweight.

Actuate the brake valve without a coupling pin:

- Remove the rubber mat.
- Remove the bottom plate.
- Press the brake valve plate (3) down repeatedly.

The spring-operated brake is released.

i NOTE

To fully release the spring-operated brake, press down on the brake valve plate at least 30 times. The pressure that builds up in the brake hydraulics as a result releases the spring-operated brake.

- After releasing the spring-operated brake, re-install the bottom plate and the rubber mat.

⚠ WARNING

Risk of injury through falling or slipping!

If the bottom plate is not inserted, there is a danger of footwear getting stuck, causing you to fall. Even when the bottom plate is installed, there is still a danger of slipping and injury if the rubber mat is not used.

- Install the bottom plate and rubber mat.

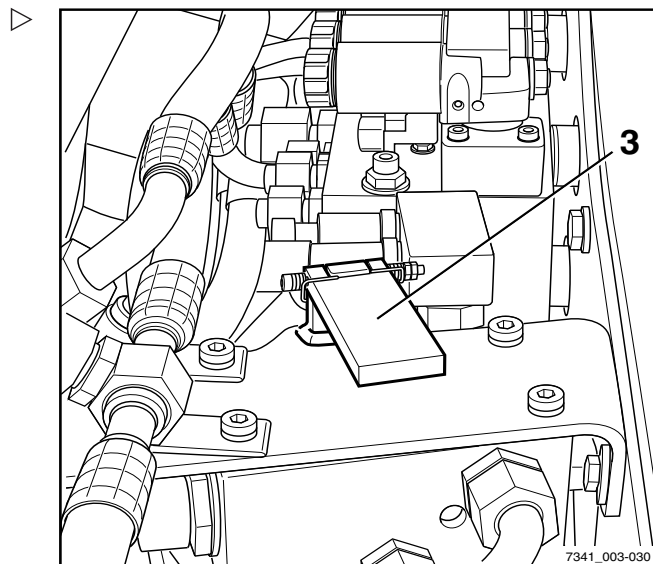
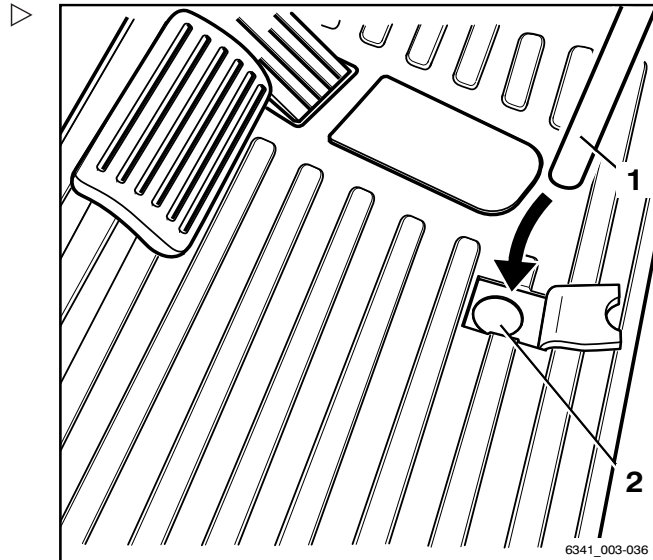

Towing

⚠ DANGER

Risk of accident due to failure of the brake system of the towing vehicle!

If the brake system of the towing vehicle is not adequately sized, the vehicle may not brake safely or the brakes may fail. The towing vehicle must be designed such that it is able to absorb the tractive and braking forces from the unbraked towed load (the actual total weight of the truck).

- Check the tractive and braking forces of the towing vehicle.

⚠ DANGER

If the towing vehicle brakes, there is a risk that the truck will drive into the towing vehicle!

If a rigid connection has not been used for power transmission in two directions during towing, the truck may drive into the towing vehicle when the towing vehicle brakes. Use a tested tow bar for safety reasons.

- Use a tested tow bar.

⚠ CAUTION

If the truck drive between the drive motor and the drive axle is not interrupted, the drive may be damaged.

- Place the drive direction switch in the neutral position.

⚠ CAUTION

Risk of damage to the battery male connector when disconnecting!

If the battery male connector is disconnected while the key switch is switched on under load, an arc will be produced. The arc can damage the contacts and considerably shorten the service life of the contacts.

- Switch off the key switch.
- Only disconnect the battery male connector while the key switch is switched off.

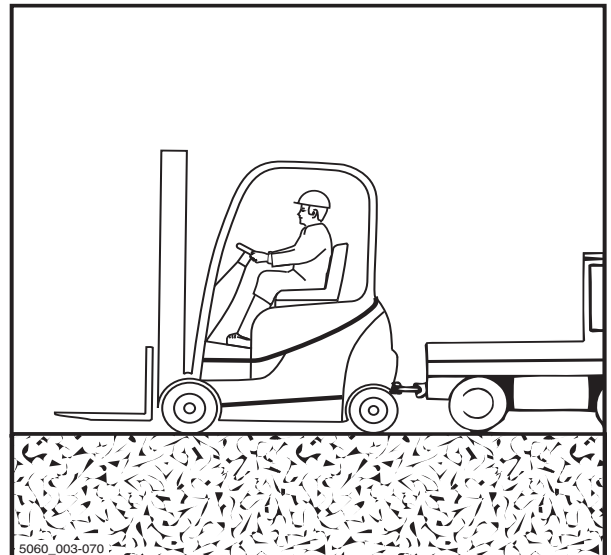

Procedure in emergencies

⚠ DANGER

While manoeuvring, there is a risk of fatal injury in the area between the truck and the towing vehicle!

Inform the driver of the towing vehicle and the mechanic attaching the tow bar about the risks. When you fit the tow bar, always use a second person to guide the towing vehicle manoeuvres.

- Manoeuvre with a second person as a guide.

⚠ CAUTION

Steering is stiff! There is no power steering if the hydraulics fail!

- Select a slow towing speed to ensure that the truck and the towing vehicle can be braked and controlled effectively at all times.

⚠ CAUTION

If the truck is not steered while it is being towed, the truck may veer out in an uncontrolled manner!

- The truck being towed must also be steered by a driver.
- The driver of the truck being towed must sit in the driver's seat and fasten the seat belt before towing.
- Where possible, activate the restraint systems provided.

⚠ CAUTION

Component damage as a result of blocked brakes!

The truck is equipped with a negative spring-operated brake. As a result, when you switch off the truck, the multi-disc brakes in the drive wheel units block. For towing, the brake must be released at the brake valve. Otherwise, the truck is towed with the wheels blocked.

Once the spring-operated brake is released, pressure builds up gradually again in the brake hydraulics. The brakes can block again. Note the towing time when the key switch is switched off. The towing process must be interrupted in each case and the brake released again.

- Releasing the spring-operated brake
 - Note the towing time and release the spring-operated brake again as necessary.
-
- Set down the load and lower the fork arms close to the ground.
 - Place the drive direction switch in the neutral position.



- Apply the parking brake.
- Switch off the key switch.
- Disconnect the battery male connector.
- Check the tractive and braking forces of the towing vehicle.
- With the help of a guide, manoeuvre the towing vehicle to the truck.
- Secure the tow bar to the tow coupling on the towing vehicle and on the truck.
- Release the spring-operated brake
- Sit in the driver's seat of the truck being towed and fasten the seat belt.
- Where possible, activate the restraint systems provided.
- Release the parking brake.
- Select a slow towing speed.
- Tow the truck.
- Note the towing time (refer to the table in the section entitled "Releasing the spring-operated brake") and release the spring-operated brake again as necessary.
- After towing, secure the truck so that it cannot roll away (e.g. by applying the parking brake or by using wheel chocks).
- Remove the tow bar.

Transporting the truck

Transporting the truck

Transportation

⚠ CAUTION

Risk of material damage from overloading!

If the truck is driven onto a means of transport, the load capacity of the means of transport, the ramps and the loading bridges must be greater than the actual total weight of the truck. Components can be permanently deformed or damaged due to overloading.

- Determine the total actual weight of the truck.
- Only load the truck if the load capacity of the means of transport, the ramps and the loading bridges is greater than the actual total weight of the truck.

Determining the total actual weight

- Park the truck securely.
- Determine the unit weights by reading the truck nameplate and, if necessary, the attachment nameplate (variant).
- Add the determined unit weights to obtain the total actual weight of the truck:

Tare weight (1)

- + Max. permissible battery weight (2)
- + Ballast weight (variant) (3)
- + Attachment net weight (variant)
- + 100-kg allowance for driver
- = Total actual weight

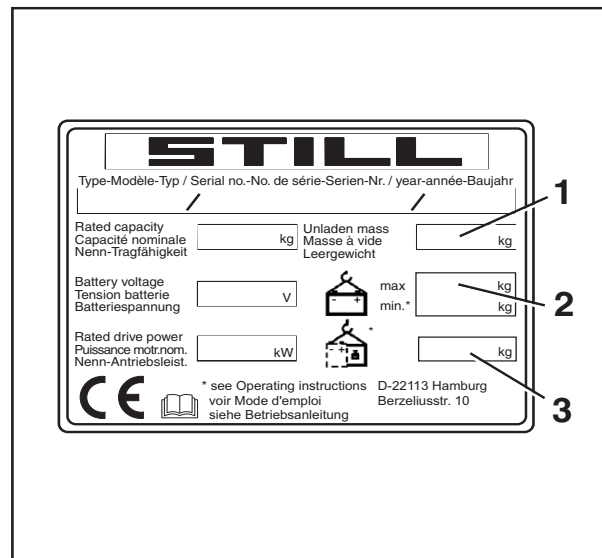

⚠ DANGER

Risk of accident from the truck crashing!

Steering movements can cause the tail end to veer off the loading bridge towards the edge. This may cause the truck to crash.

- Before driving across a loading bridge, ensure that the loading bridge is properly attached and secured.
- Ensure that the transport vehicle onto which the truck is to be driven has been sufficiently secured against moving.
- Maintain a safety distance from edges, loading bridges, ramps, working platforms etc.
- Drive slowly and carefully onto the transport vehicle.

Inserting wedges

- Secure the truck from rolling away by placing a wheel chock (1) in front of each front wheel and behind each back wheel.
- Park the truck securely.

⚠ CAUTION

Risk of damage to the battery male connector when disconnecting!

If the battery male connector is disconnected while the key switch is switched on under load, an arc will be produced. The arc can damage the contacts and considerably shorten the service life of the contacts.

- Switch off the key switch.
- Only disconnect the battery male connector while the key switch is switched off.

- Ensure that the key switch is switched off.
- Disconnect the battery male connector.

Lashing down

⚠ CAUTION

Harnesses can rub against the seating and cause damage!

- Place a slip-resistant material between the harness and the seating, e.g. rubber mats or foam.

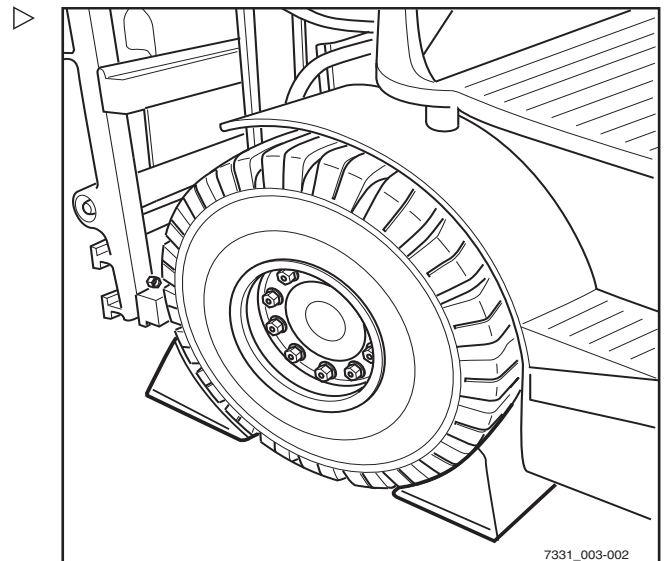

4

Operation

Transporting the truck

- Attach a harness (1) to each side of the truck. Lash the truck towards the rear.
- Attach a harness (1) to the coupling pin (2) or loop the harness around the coupling pin.

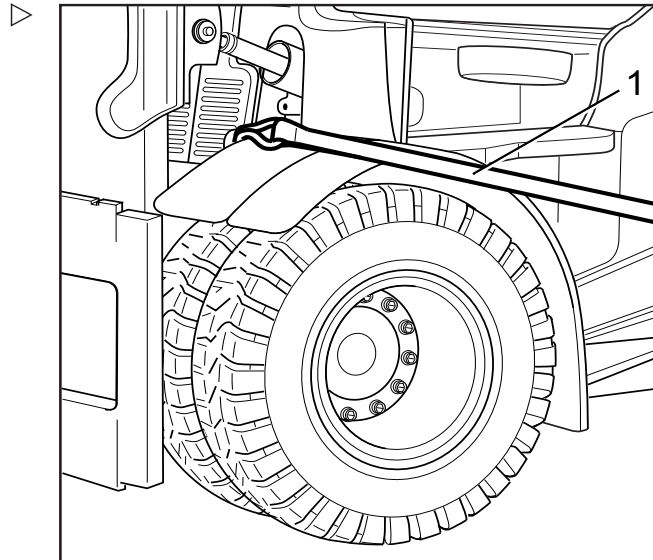

- Lash the truck to the side.

⚠ DANGER

The truck may slip if the harnesses slip!

The truck must be lashed securely to ensure that it does not move during transportation.

- Ensure that the harnesses are tightened securely and that the pads cannot slip off.

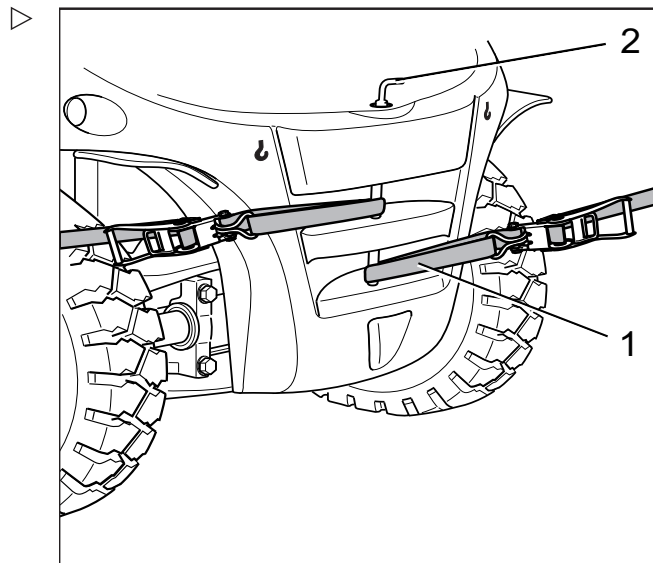

Crane loading

Crane loading is only intended for transporting the complete truck, including the lift mast, for its initial commissioning. For application conditions that require frequent loading or that are not dealt with here, please contact the manufacturer with regard to special equipment variants.

Trucks may only be laden by persons with sufficient experience with the suitable harnesses and hoists.

Determining the loading weight

- Park the truck securely; see the chapter entitled "Parking the truck securely".
- Determine the unit weights by reading them off the truck nameplate and, if necessary, the attachment (variant) nameplate.
- Add the determined unit weights to obtain the loading weight of the truck:

Unladen weight (1)

+ Max. permissible battery weight (2)

+ Ballast weight (variant) (3)

+ Attachment net weight (variant)

= Loading weight



Hooking on the lifting straps

⚠ CAUTION

Harnesses may damage the truck's paintwork!
 Harnesses may damage paintwork by rubbing and pressing on the surface of the truck. Particularly hard or sharp-edged harnesses, such as wires or chains, can quickly damage the surface.

- Use textile harnesses, e.g. lifting straps, with edge protectors or similar protective devices where necessary.



⚠ DANGER

There is a risk of fatal injury if the hoists and harnesses fail and cause the truck to fall!

- Only use hoists and harnesses with sufficient load capacity for the determined loading weight.
- Only use the truck's designated lifting points.
- Make sure that harness parts such as hooks, shackles, belts and similar items are only used in the indicated load direction.
- The harnesses must not be damaged by truck parts.

4 Operation

Transporting the truck

i NOTE

The lifting points are indicated by a hook symbol.

- Loop the lifting straps around the main traverse (3) on the outer mast of the lift mast as shown.

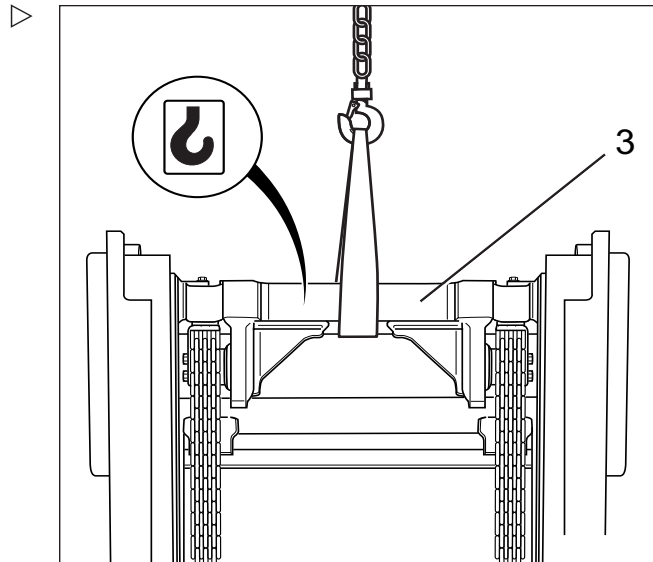

- Loop the lifting straps around the counterweight (4) as shown.
- Determine the truck's centre of gravity, see chapter entitled "Dimensions".

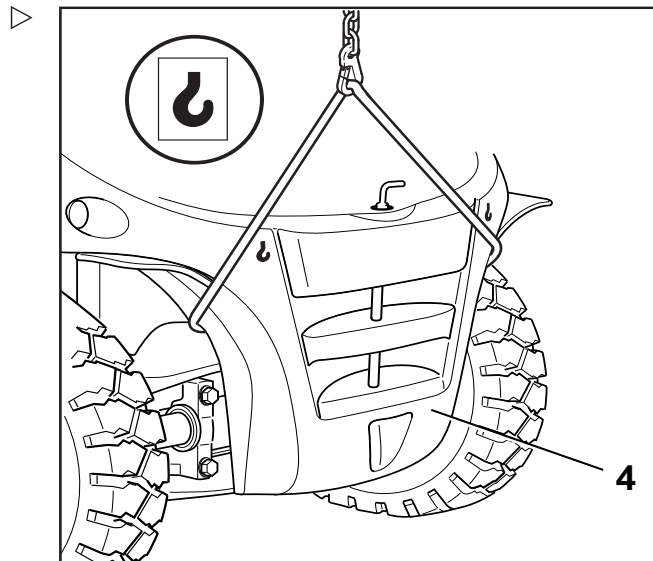

Operation

4

Transporting the truck

- Adjust the length of the harnesses so that the lifting eye (6) is vertically above the truck's centre of gravity.

This ensures that the truck hangs level when lifted.

- Attach the lifting straps to the lifting eye and insert the safety device (5).

CAUTION

Incorrectly fitted harnesses may damage attachment parts!

Pressure from the harnesses can damage or destroy attachment parts when the truck is lifted. If attachment parts are in the way (e.g. lighting, rear window, trademark emblem etc.), these must be removed before loading.

- Secure harnesses in such a way that they do not touch any attachment parts.
-
- Check that harnesses cannot come into contact with attachment parts.

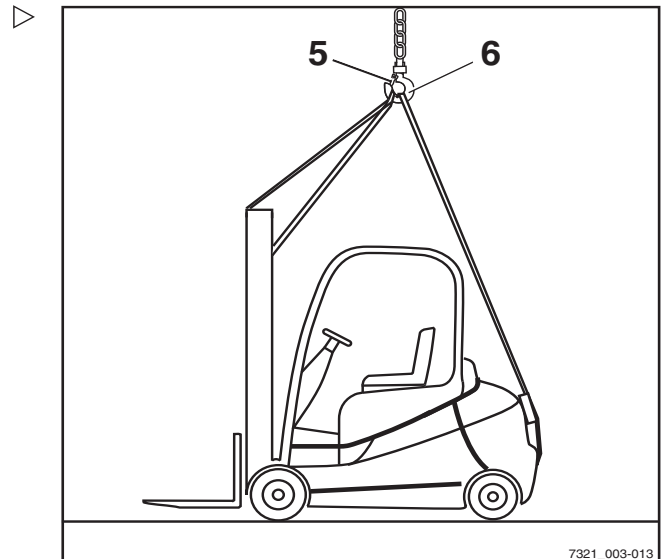

Loading the truck



DANGER

If the raised truck swings in an uncontrolled manner, it may crush people. There is a risk of fatal injury!

- Never walk or stand underneath suspended loads.
 - Do not allow the truck to bump into anything whilst it is being lifted, or allow it to move in an uncontrolled manner.
 - If necessary, hold the truck using guide ropes.
-
- Carefully lift the truck and set it down at the intended location.

Shutdown

Shutdown

Shutting down and storing the truck

⚠ CAUTION

Component damage due to incorrect storage!

Storing the truck improperly or decommissioning the truck for more than two months will result in corrosion on the truck. If the truck is parked in an area with an ambient temperature of below -10°C for an extended period, the batteries will cool down. The electrolyte may freeze and damage the batteries.

- Implement the following measures before shutting down.

⚠ CAUTION

Risk of damage to the battery male connector when disconnecting!

If the battery male connector is disconnected while the key switch is switched on under load, an arc will be produced. The arc can damage the contacts and considerably shorten the service life of the contacts.

- Switch off the key switch.
- Only disconnect the battery male connector while the key switch is switched off.

⚠ CAUTION

Tyre deformation as a result of continuous loading on one side!

Keeping all wheels clear of the ground prevents permanent deformation of the tyres.

- Have the truck raised and jacked up by the authorised service centre.

⚠ CAUTION

Danger of damage from corrosion due to condensation on the truck!

Many plastic films and synthetic materials are watertight. Condensation water on the truck cannot escape through these covers.

- Do not use plastic film as this facilitates the formation of condensation water.



NOTE

Only store batteries that are fully charged.



Measures to be implemented before shutdown

- Store the truck in a dry, clean, frost-free and well-ventilated environment.
- Clean the truck thoroughly; see the chapter entitled "Cleaning".
- Lift the fork carriage to the stop several times.
- Tilt the lift mast forwards and backwards several times and move the attachment repeatedly, if an attachment is fitted.
- To relieve the strain on the load chains, lower the fork onto a suitable supporting surface, e.g. a pallet.
- Check the hydraulic oil level and top up if required.
- Apply a thin layer of oil or grease to all uncoated moving parts.
- Lubricate the truck.
- Oil joints and controls.
- Lubricate the battery cover interlock.
- Ensure that the key switch is switched off. Then disconnect the battery male connector.
- Check the battery condition, acid level and acid density.
- Service the battery.
- Spray all exposed electrical contacts with a suitable contact spray.
- Only have the truck raised and jacked up by the authorised service centre.
- Cover the truck with vapour-permeable material, such as cotton, in order to protect the truck against dust.
- If the truck will be shut down for longer periods, contact the authorised service centre to find out about additional courses of action.

Shutdown

Re-commissioning after shutdown

If the truck has been decommissioned for longer than six months, the truck must be carefully checked before being recommissioned. As with the yearly safety inspection, this check must also include all safety-related aspects of the truck.

- Thoroughly clean the truck.
- Oil joints and controls.
- Lubricate the lubrication points.
- Check the condition and the acid density of the battery. Charge the battery if necessary.
- Check the hydraulic oil for condensation water and replace if necessary.
- Have the same checks and tasks carried out by the authorised service centre that were carried out before initial commissioning.
- Carry out the checks and tasks that are to be performed before daily use.
- Recommission the truck.

During recommissioning, the following points in particular must be checked:

- Drive, controller, steering
- Brake system (service brake, parking brake, regenerative brake)
- Lifting system (lifting accessories, load chains, mounting)

NOTE

For further information, see the workshop manual for the truck and contact the authorised service centre.



5

Maintenance

Safety regulations for maintenance

Safety regulations for maintenance

General information

To prevent accidents during maintenance and repair work, all necessary safety measures must be taken, e.g.:

- Apply the parking brake.
- Turn off the key switch and remove the key.
- Disconnect the battery male connector.
- Ensure that the truck cannot move unintentionally or start up inadvertently.
- If required, have the truck jacked up by the authorised service centre.
- Have the raised fork carriage or the extended lift mast secured against accidental lowering by the authorised service centre.
- Insert an appropriately sized wooden beam as an abutment between the lift mast and the cab, and secure the lift mast to prevent it tilting backwards unintentionally.
- Observe the maximum lift height of the lift mast, and compare the dimensions from the technical data with the dimensions of the hall into which the truck is to be driven. These steps are taken to prevent a collision with the ceiling of the hall and to avoid any damage caused as a result.

Working on the hydraulic equipment

The hydraulic system must be depressurised prior to all work on the system.

Working on the electrical equipment

Work may only be performed on the electrical equipment of the truck when it is in a voltage-free state. Function checks, inspections and adjustments on energised parts must only be performed by trained and authorised persons, taking the necessary precautions into account. Rings, metal bracelets etc. must be removed before working on electric components.



To prevent damage to electronic systems with electronic components, such as an electronic driving regulator or lift control, these components must be removed from the truck prior to the start of electric welding.

Work on the electrical system (e.g. connecting a radio, additional headlights etc.) is only permitted with approval from the authorised service centre.

Safety devices

After maintenance and repair work, all safety devices must be reinstalled and tested for operational reliability.

Set values

The device-dependent set values must be observed when making repairs and when changing hydraulic and electrical components. These are listed in the appropriate sections.

Lifting and jacking up

DANGER

There is a risk to life if the truck tips over!

If not raised and jacked up properly, the truck may tip over and fall off. Only the hoists specified in the workshop manual for this truck are allowed and are tested for the necessary safety and load capacity.

- Only have the truck raised and jacked up by the authorised service centre.
- Only jack the truck up at the points specified in the workshop manual.

The truck must be raised and jacked up for various types of maintenance work. The authorised service centre must be informed that this is to take place. Safe handling of the truck and the corresponding hoists is described in the truck's workshop manual.



Safety regulations for maintenance

Working at the front of the truck

⚠ DANGER

Risk of accident!

If the lift mast or fork carriage is raised, no work may be performed on the lift mast or at the front of the truck unless the following safety measures are observed.

- When securing, only use chains with sufficient load-bearing capacity.
- Contact the authorised service centre.

⚠ CAUTION

Possibility of damage to the ceiling!

- Note the maximum lift height of the lift mast.

Securing the lift mast against tilting backwards

A hardwood beam with a cross-section of 120 x 120 mm is required. The length of the hardwood beam must approximately correspond to the width of the fork carriage (b3). To avoid impact injuries, the hardwood beam must not protrude beyond the outer contour of the truck. A maximum length matching the total width (b1) of the truck is recommended.

- Obtain the dimensions (b1) and (b3) from the corresponding VDI datasheet.

- Clamp the hardwood beam (1) between the driver protection structure (2) and the lift mast (3).

Removing the lift mast

⚠ DANGER

Risk of accident!

This work must only be performed by an authorised service technician.

- Arrange for an authorised service technician to remove the lift mast.

Securing the lift mast against falling off

⚠ DANGER

Risk of accident!

This work must only be performed by an authorised service technician.

- Arrange for an authorised service technician to secure the lift mast.

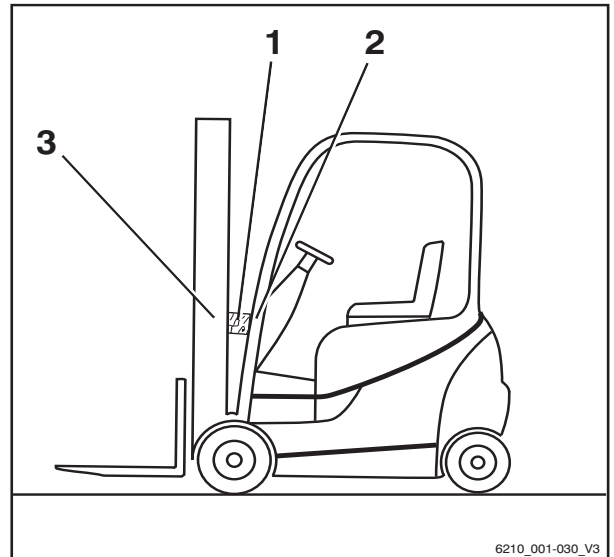

6210_001-030_V3



General maintenance information

General maintenance information

Personnel qualifications

Only qualified and authorised personnel are allowed to perform maintenance work. Regular safety checks and checks after unusual incidents must be performed by a competent person. The competent person must conduct their evaluation and assessment from a safety standpoint, unaffected by operational and economic conditions. The competent person must have sufficient knowledge and experience to be able to assess the condition of a truck and the effectiveness of the protective devices in accordance with technical conventions and the principles for testing trucks.

Maintenance personnel for batteries

Batteries may only be charged, serviced, and replaced by personnel who have received appropriate training in accordance with the instructions from the manufacturers of the battery, battery charger and truck.

- Follow the handling instructions for the battery and the operating instructions for the battery charger.

Maintenance work without special qualifications

Simple maintenance work, such as checking the hydraulic oil level, may be carried out by untrained personnel. A qualification such as those held by a competent person is not required to carry out this work. The required tasks are described in the chapter entitled "Remaining ready for operation".

Information for carrying out maintenance

This section contains all information required to determine when the truck needs maintenance. Carry out maintenance work within the time limits according to the hour meter and using the following maintenance check lists. This is the only way to ensure that the truck remains ready for operation and provides op-

timal performance and service life. It is also a precondition for any warranty claims.

Maintenance timeframe

- Carry out maintenance work on the truck in accordance with the "Service in" display (1).
- The maintenance check lists indicate the maintenance work that is due.

The intervals are defined for standard use. Shorter maintenance intervals can be defined in consultation with the operating company, depending on the application conditions of the truck.

The following factors may necessitate shorter maintenance intervals:

- Contaminated, poor quality roads
- Dusty or salty air
- High levels of air humidity
- Extremely high or low ambient temperatures, or extreme changes in temperature
- Multi-shift operation with a high duty cycle
- Specific national regulations for the truck or individual components

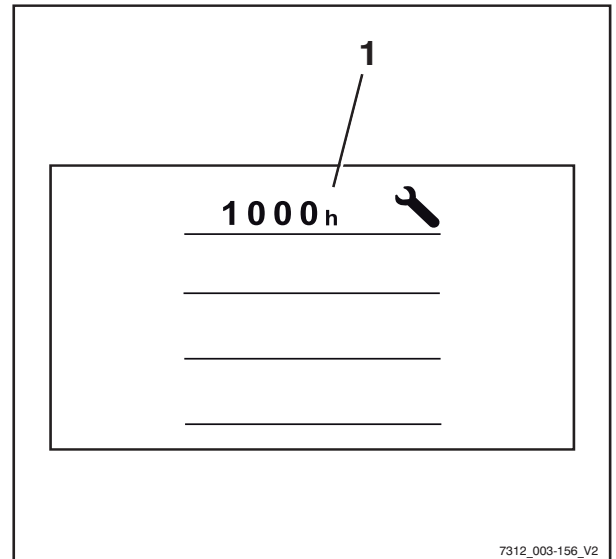



5

Maintenance

General maintenance information



Maintenance - 1000 hours/annually

At operating hours										Carried out	
1000		2000		4000		5000		7000			
8000		10000		11000		13000		14000		✓	✗
Chassis, bodywork and fittings											
Check the chassis for cracks											
Check the overhead guard/cab and panes of glass for damage											
Check the controls, switches and joints for damage, and apply grease and oil											
Check the driver's seat for correct function and for damage											
Check the driver restraint system for correct function and for damage, and clean											
Check the battery door and interlock for correct function and for damage											
Check the indexing bolt for the battery pallet lock for damage											
Check the signal horn											
Variant: Check the dual pedal for damage and correct function, and lubricate											
Tyres and wheels											
Check the tyres for wear and check the air pressure if necessary											
Check the wheels for damage and check the tightening torques.											
Power unit											
Drive axle: Check mounting, check for leaks, clean cooling fins											
Check the oil level in the drive wheel unit											
Change gearbox oil (once after 1000 hours)											
Steering											
Check the steering system for correct function and for leaks											
Check that the steering wheel is securely attached and check the turning handle for damage											
Steering axle: Check that the steering axle is securely attached, check for leaks and apply grease											
Check the steering stop											
Brake											
Check the condition of all mechanical brake parts and check for correct function											
Check the brake valve for correct function and leaks											
Check the service brake for correct function											
Check the parking brake for correct function											



5

Maintenance

General maintenance information

At operating hours									Carried out	
1000		2000		4000		5000		7000		
8000		10000		11000		13000		14000	✓	✗
Electrical system										
Check all power cable connections										
Check the contacts of the main contactors.										
Check the switches, transmitters and sensors for correct function										
Check the lighting and indicator lights										
Cooling system (power electronics and hydraulics)										
Check the coolant level and quality										
Check for correct function and leaks										
Clean the radiator, radiator grilles, exhaust air funnel and water outlet										
Battery and accessories										
Check battery for damage and acid density; observe manufacturer's maintenance instructions										
Electrolyte circulation: replace the non-return valve										
Check the battery pallet for damage.										
Check the appliance plug and truck harness for damage.										
Check the battery male connector and battery harness for damage										
Hydraulics										
Check the condition of the hydraulic system, and check for correct function and leaks										
Check the hydraulics blocking function (ISO valve)										
Check the oil level										
Lift mast										
Check the mast bearings for damage, lubricate them, and check the tightening torque										
Check the mast profiles for damage and wear. Lubricate the mast profiles										
Check the guide in the lower (load reversal) mast profile for damage and for wear										
Check the load chains for damage and wear. Adjust and lubricate the load chains										
Check the lift cylinders and connections for damage and leaks										
Check the guide pulleys for damage and wear										
Check the support rollers and chain rollers for damage and wear										
Check the play between the fork carriage stop and the run-out barrier										
Check the tilt cylinders and connections for damage and leaks										



Maintenance

5

General maintenance information

At operating hours										Carried out	
1000		2000		4000		5000		7000			
8000		10000		11000		13000		14000			
Check the fork carriage for damage and wear											
Check the fork arm interlock for damage and correct function											
Check the fork arms for wear and deformation											
Check that there is a safety screw on the fork carriage or on the attachment											
Check the auxiliary hydraulics hoses for damage											
Special equipment											
Heating system: Replace the fresh air filter											
Heating system: Replace the recirculated air filter											
Check the heating system for damage; observe the manufacturer's maintenance instructions											
Check the attachments for wear and damage; observe the manufacturer's maintenance instructions											
Check the trailer coupling for wear and damage; observe the manufacturer's maintenance instructions											
General											
Read out the error numbers and delete the list											
Reset the maintenance interval											
Check the labelling to ensure it is complete											
Perform a test drive											

General maintenance information

Maintenance - 3000 hours/every two years

At operating hours								Carried out			
3000		6000		9000		12000		15000	✓	*	
Note											
Perform all 1000-hour maintenance work.											
Power unit											
Change the gearbox oil											
Replace the bleeder screws on the drive wheel units											
Cooling system (power electronics and hydraulics)											
Replace the coolant (every 2 years)											
Hydraulics											
Change the hydraulic oil											
Replace the return line filter and the breather filter											
Replace the high-pressure filter											
Variant: Replace the accumulator											

Ordering spare parts and wearing parts

Spare parts are provided by our spare parts service department. The information required for ordering parts can be found in the spare parts list.

Only use spare parts as per the manufacturer's instructions. The use of unapproved spare parts can result in an increased risk of accidents due to insufficient quality or incorrect assignment. Anyone using unapproved spare parts shall assume unlimited liability in the event of damage or harm.

Quality and quantity of the required operating materials

Only the operating materials specified in the maintenance data table may be used.

- The required consumables and lubricants can be found in the maintenance data table.



Oil and grease types of a different quality must not be mixed. This negatively affects the lubricity. If a change between different manufacturers cannot be avoided, drain the old oil thoroughly.

Before carrying out lubricating work, filter changes or any work on the hydraulic system, carefully clean the area around the part involved.

When topping up working materials, use only clean containers!

5 Maintenance

General maintenance information

Lubrication plan

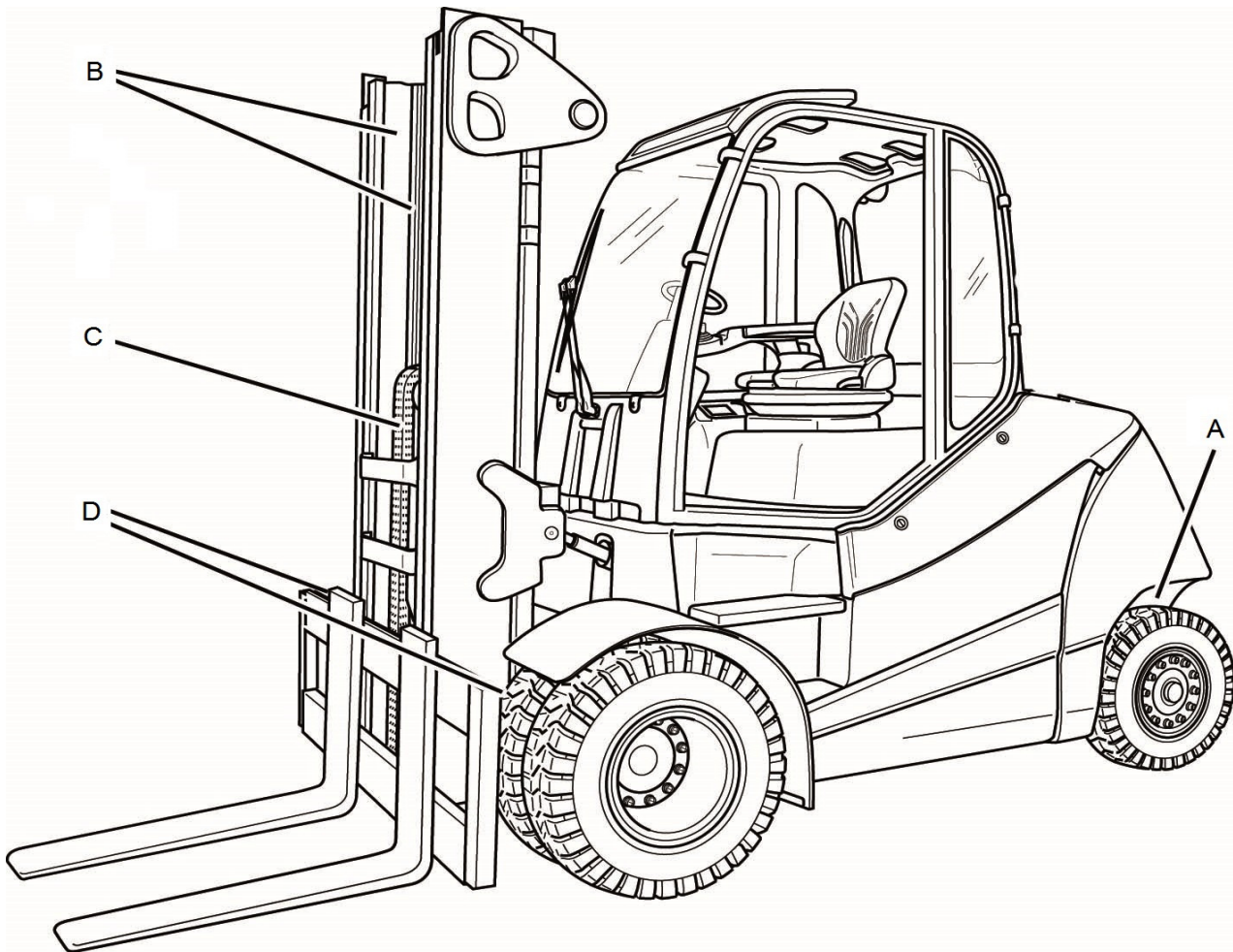

Code ¹	Lubrication point
(A)	Four lubricating nipples on each side of the steering axle for the axle stub bearing and track rod arm
(B)	Sliding surfaces on the lift mast
(C)	Load chains
(D)	One lubricating nipple on each of the two lift mast bearings

¹See the following chapter, "Maintenance data table", under this Code. for the respective lubricant specification This lubrication plan describes the series-production truck with standard equipment. For maintenance points on variant trucks, see the relevant chapter and/or instructions provided by the manufacturer.

Maintenance data table

General lubrication points

Code	Unit	Operating material	Specifications	Measurement
	Lubrication	High-pressure grease	ID no. 0147873	As required

Battery

Code	Unit	Operating material	Specifications	Measurement
	System contents	Distilled water		As required
	Insulation resistance		DIN 43539 VDE 0510	For further information, refer to the workshop manual for the truck in question.

Electrical system

Code	Unit	Operating material	Specifications	Measurement
	Insulation resistance		DIN EN 1175 VDE 0117	For further information, refer to the workshop manual for the truck in question.

Controls/joints

Code	Unit	Operating material	Specifications	Measurement
	Lubrication	High-pressure grease	ID no. 0147873	As required
		Oil	SAE 80 MIL-L2105 API-GL4	As required
	Dual pedal operation	High-pressure grease	ID no. 0147873	As required

Hydraulic system

Code	Unit	Operating material	Specifications	Measurement
	System contents	Hydraulic oil	HVLP 68 or ISO VG 68 DIN 51524, part 2	Max. 125 l
		Hydraulic oil for the food industry (variant)	USDA H1 DIN 51524	

5 Maintenance

General maintenance information

Tyres

Code	Unit	Operating material	Specifications	Measurement
	Superelastic tyres	Minimum tread depth		Min. 1.6 mm
		Wear limit		To wear mark

AL80-01 steering axle

Code	Unit	Operating material	Specifications	Measurement
	Wheel nuts/screws	Torque wrench	DIN 74361-A 20-10 A2C	640 Nm
(A)	Axle stub bearing, spherical bearing	Grease	Aralub 4320 DIN 51825-KPF2N20 ID no. 0148659	Fill with grease until a small amount of fresh grease escapes
(A)	Wheel bearing, wheel bearing rotary shaft seal	Grease	DIN 51825-KP2 K-30, lithium-saponified ID no. 0163488	Fill with grease

AE80-02 drive axle

Code	Unit	Operating material	Specifications	Measurement
	System contents incl. service brake	Gearbox oil	SAE 80W-90 API-GL4	For further information, refer to the workshop manual for the truck in question.
			ARAL EP Plus 80W-90 BP Energear HT 80W-90 Castrol Syntrox Universal 80W-90	
	Wheel nuts/screws	Torque wrench	DIN 74361-A 20-10 A2C	640 Nm

Lift mast

Code	Unit	Operating material	Specifications	Measurement
(B)	Lubrication	High-pressure grease	ID no. 0147873	As required
	Stop	Play		Min. 2 mm
	Screws for the lift mast bearing	Torque wrench	Cylinder head bolt M24x90-12.9 ISO 4762	1100 Nm
(D)	Lift mast bearing	Grease	Aralub 4320 DIN 51825-KPF2N20 ID no. 0148659	Fill with grease until a small amount of fresh grease escapes

Maintenance

5

General maintenance information

Load chains

Code	Unit	Operating material	Specifications	Measurement
(C)	Lubrication	High-load chain spray	Fully synthetic Temperature range: -35°C to +250°C ID no. 0156428	As required

Cooling system (power electronics/hydraulic oil)

Code	Unit	Operating material	Specifications	Measurement
	System contents	Corrosion inhibitor and cooling system protecting agent/water	40% coolant/60% water, for frost protection down to -25 C VW G12 plus (violet) TL-VW 774 F	Approx. 4.5 l

Washer system

Code	Unit	Operating material	Specifications	Measurement
	System contents	Washer fluid	Winter, ID no. 172566	As required

Providing access to maintenance points

Providing access to maintenance points

Removing and attaching the left side cover

Removing the cover

- Release the quick release clamps (1) with a 1/4 revolution.
- Remove the cover (2) and put carefully aside.

Attaching the cover

- Carefully position the cover (2).
- Lock the quick release clamps (1) with a 1/4 turn.

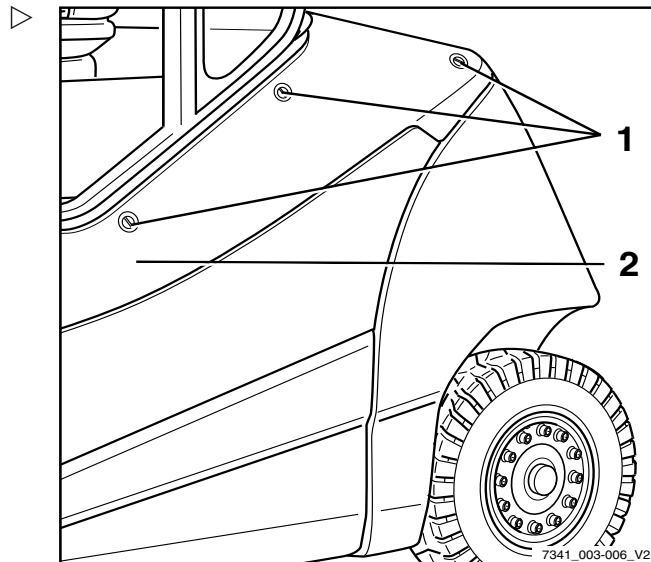

Installing and removing the bottom plate

Removing the bottom plate.

⚠ CAUTION

Risk of short circuit if cables are damaged!

- Check the connecting cables for damage.
- When removing and reinstalling the bottom plate, make sure that the connecting cables are not damaged.

⚠ CAUTION

Placing the bottom plate on top of the rubber edging strip can cause damage to the rubber edging strip.

- Do not place the bottom plate on top of the rubber edging strip.

i NOTE

The bottom plate has a recess that the operator can insert his fingers into to lift it. The recess is beneath the rubber mat.

Maintenance

5

Providing access to maintenance points

NOTE

The accelerator pedal is attached to the bottom plate and is removed with this also. The connecting plug for the accelerator is located underneath the bottom plate.

- Open the bonnet.
- Remove the rubber mat.
- Grasp the recess (3) in the bottom plate (2). ▷
- Raise the bottom plate slightly.
- Pull out the bottom plate under the brake pedal and set it down upright.

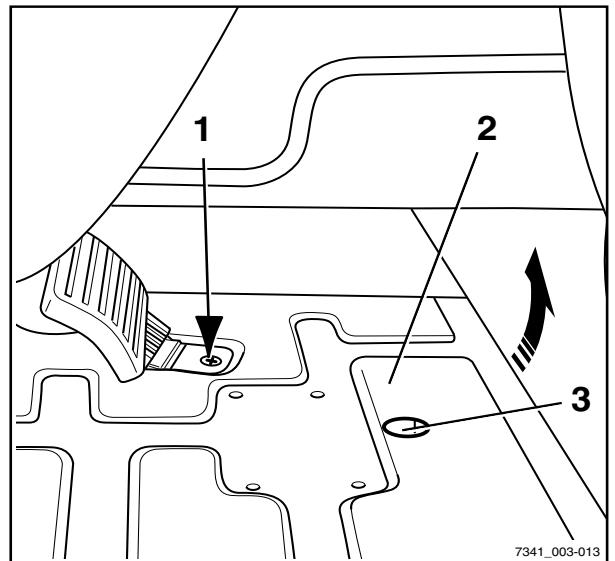

- Disconnect the plug connector (1) on the accelerator pedal. ▷
- Lift bottom plate and place in a safe location.

Installing the bottom plate

WARNING

Risk of crushing between bottom plate and frame edge!

If limbs or objects are between the bottom plate and frame edge when the bottom plate is closed, they can be crushed.

- When closing the bottom plate, ensure that there is nothing between the bottom plate and the edge of the chassis.

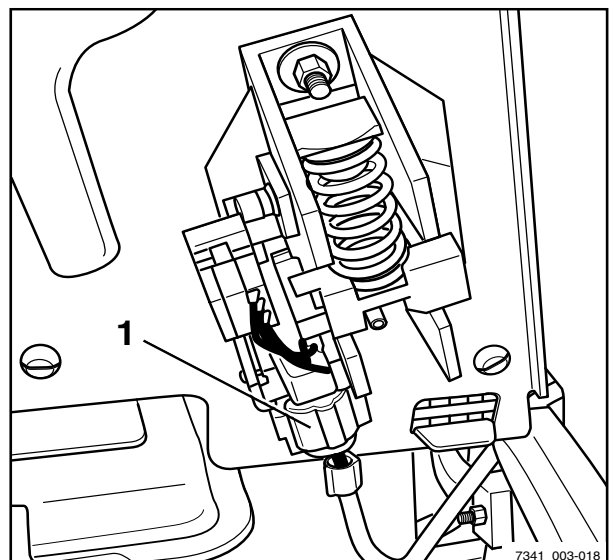

CAUTION

Placing the bottom plate on top of the rubber edging strip can cause damage to the rubber edging strip.

- Do not place the bottom plate on top of the rubber edging strip.

5

Maintenance

Providing access to maintenance points

- Set down the bottom plate upright in the footwell.
- Connect the connection assembly to the accelerator pedal.
- Position the bottom plate at the front.
- Carefully guide the bottom plate down and close.
- Insert the rubber mat.
- Close the bonnet.

Opening/closing the front right cover

Opening the cover

⚠ WARNING

Risk of injury through crushing if the cover falls down!

The cover is equipped with a gas spring that holds the cover in the open position unless there is any other load on it, e.g. heavy objects, strong winds or other persons.

- There must be no objects on the cover when you open it.
- Make sure that the cover is not being pushed down by strong winds or other persons.

- Release the quick release clamp (3) with a \triangleright 1/4 revolution.
- Swivel the cover (2) upwards.

The cover is held in the opened position by the gas spring.

Closing the cover

⚠ WARNING

Risk of crushing between cover and frame edge!

If limbs or objects are between the cover and frame edge when the cover is closed, they can be crushed.

- Make sure when you close the cover that there is nothing between the cover and the frame edge.

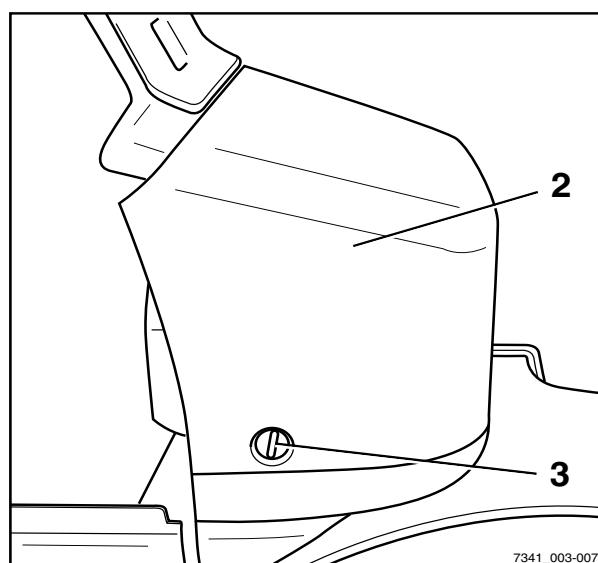

Maintenance

5

Providing access to maintenance points

- Swivel the cover (2) downwards.
- Lock the quick release clamp (3) with a 1/4 revolution.

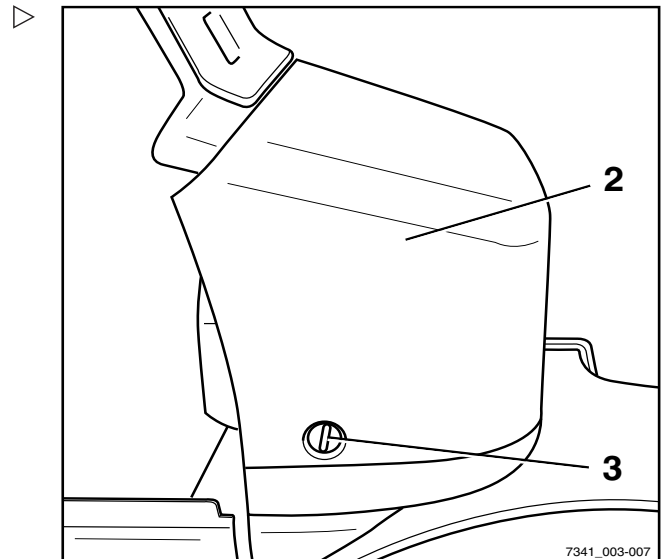

Removing and attaching the rear cover

⚠ CAUTION

Risk of component damage!

If a load is placed on the exhaust air grille (2), this can lead to deformation or cause the exhaust air grille to come away.

- Do not lean or step on the exhaust air grille.
- Do not place any objects on the exhaust air grille.

Removing the rear cover

- Unscrew five screws (3) from the rear cover (1).
- Remove the rear cover (1).

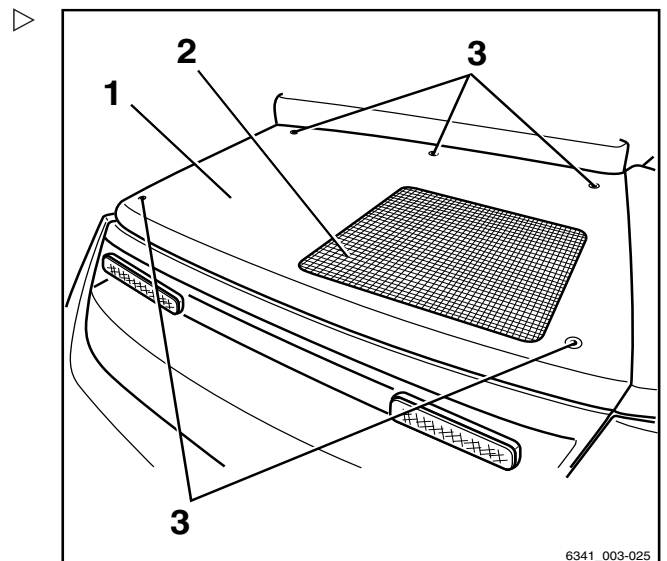

Attaching the rear cover

- Make sure that the top rubber seal of the exhaust air funnel is properly secured.
- Attach the rear cover (1).
- Screw the rear cover into place with five screws (3).

Preserving operational readiness

Preserving operational readiness

Checking the coolant level

⚠ WARNING

Risk of scalding due to hot coolant!

The cooling system is pressurised! Opening the cooling fluid tank may result in hot cooling fluid leaking out. Only open the cooling fluid tank when the cooling system is cool.

- Switch off the truck and allow it to cool down.
- Do not open the coolant reservoir until the engine has cooled down.

⚠ CAUTION

Risk of overheating!

A cooling system protects the power electronics and the hydraulic oil against overheating. Loss of coolant from leaking coolant hoses or from the radiator reduces the cooling capacity and can cause components to overheat. If the cooling fluid level is low, this indicates leakages in the cooling system.

- Check the cooling system for leak tightness.
- Remove the cover on the left-hand side.
- Pull the locking pin (1) on the coolant reservoir (2) upwards.
- Pull out the coolant reservoir under the rear cover.
- Check the coolant level.

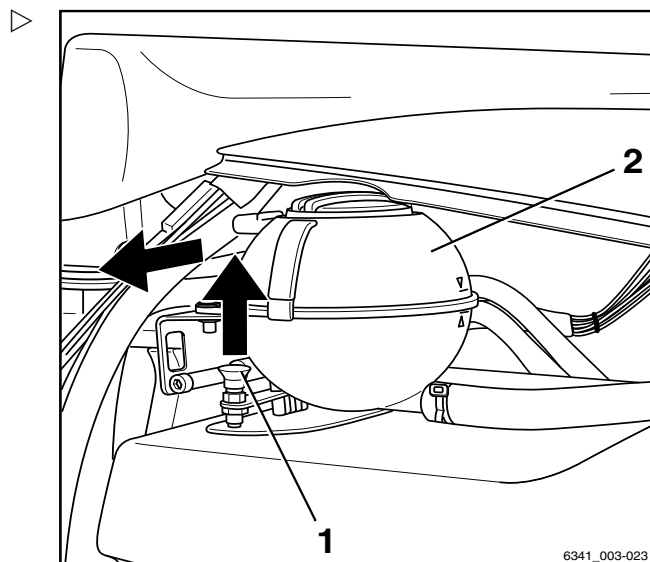

Maintenance

5

Preserving operational readiness

The cooling fluid level must be between the upper marking (4) and the lower marking (5).

- If the cooling fluid level is below the lower marking, top up the cooling fluid to no higher than the upper marking.
- Make sure that the reservoir cap (3) is screwed on and tightly sealed.
- Push the coolant reservoir (2) back in until the locking pin (1) engages.
- Fit the cover on the left-hand side.

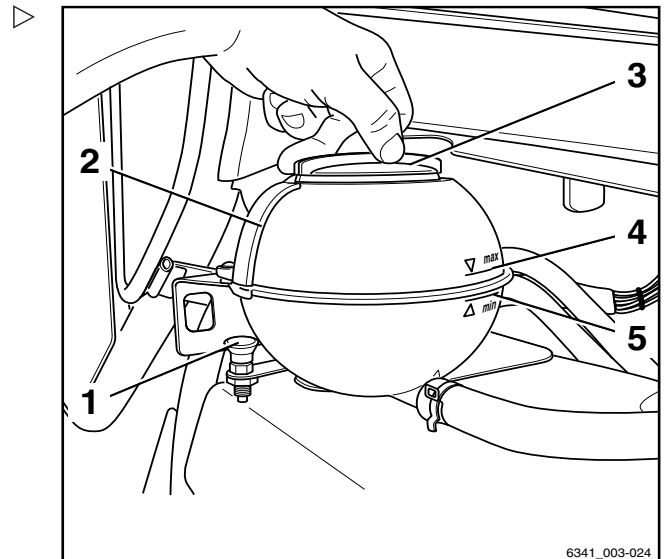

Topping up cooling fluid and checking coolant content

⚠ WARNING

Risk of scalding due to hot cooling fluid!

The cooling system is pressurised! Opening the cooling fluid tank may result in hot cooling fluid leaking out. Only open the cooling fluid tank when the cooling system is cool.

- Switch off the truck and leave it to cool down.
- Do not open the cooling fluid tank until the truck has cooled down.

⚠ WARNING

Coolant and cooling fluid can pose a hazard to health and the environment!

- Observe the safety regulations set out in the chapter entitled "Coolant and cooling fluid".
- Remove the cover on the left-hand side.

5 Maintenance

Preserving operational readiness

- Pull up the locking pin (1) on the cooling fluid tank (2).
- Pull out the cooling fluid tank from under the rear cover.
- Slowly open the tank cap (3) and release the over pressure.
- Check the concentration of the coolant.

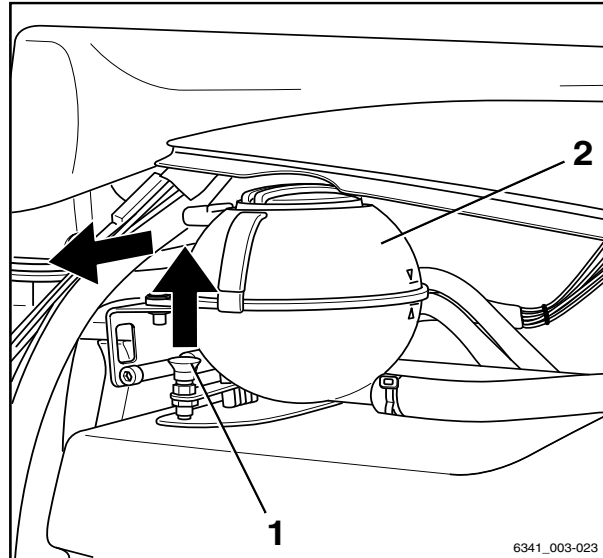

Concentration of the coolant

CAUTION

Risk of corrosion!
 The coolant percentage must be at least 40%, even if frost protection is not needed in warmer climates.
 If an increased level of frost protection is required for climatic reasons, the coolant percentage can be increased to 60%.
 The coolant percentage must not exceed 60%.
 If the coolant percentage is above 60%, the frost protection is reduced and the cooling effect is diminished.

- Only use clean, softened water for the water percentage.

CAUTION

Coolant with a different specification must not be mixed in!
 Only use coolant as set out in the maintenance data table to top up the tank.

Frost protection up to °C	Water percentage %	Coolant percentage %
-25	60	40
-30	55	45
-35	50	50
-40	40	60

- Observe the filling quantity of the cooling system; see the chapter entitled "Maintenance data table".

Maintenance

5

Preserving operational readiness

The cooling fluid level must be between the upper marking (4) and the lower marking (5).

- Check the cooling fluid level.
- If the cooling fluid level is below the lower marking, top up the cooling fluid to no higher than the upper marking
- Screw the tank cap (3) back on tightly.
- Slide the coolant tank (2) back into position until the locking pin (1) engages.
- Fit the cover on the left-hand side.

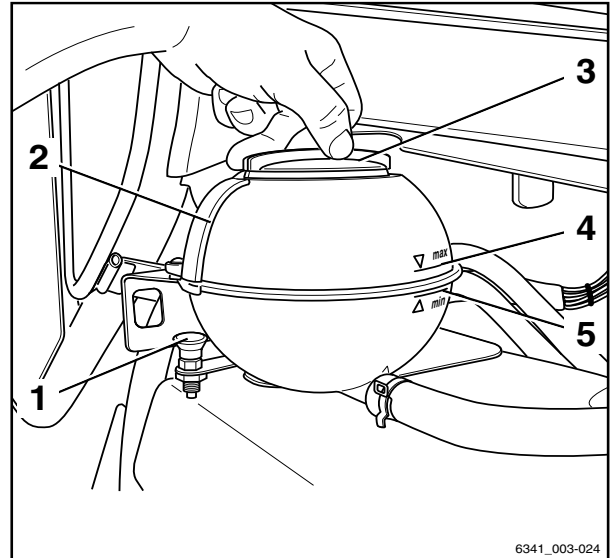

5 Maintenance

Preserving operational readiness

Cleaning the radiator and checking the radiator for leak tightness

⚠ WARNING

Risk of burns due to hot components!
Cooling system components can be so hot that direct contact may burn the skin.

- Ensure that the cooling system has cooled down.
- Do not grasp or touch hot components.
- In the event of burns, seek first aid immediately.

⚠ CAUTION

Risk of component damage due to overheating!
A cooling system protects the power electronics and the hydraulic oil against overheating. Loss of coolant from leaking coolant hoses or from the radiator reduces the cooling capacity and can cause components to overheat. If the cooling fluid level is low, this indicates a leak in the cooling system.

- Check the cooling system for leak tightness.

- Park the truck securely.
- Remove the cover on the left-hand side.
- Check the cooling fluid level.
- Remove the rear cover and clean the exhaust air grille.
- Clean the radiator grille (1), the exhaust air funnel (2) and the water drain (3) using a suitable brush or blow them out using compressed air (max. 2 bar).
- To clean the radiator behind (4), unscrew the radiator grille (1) at the screw joints (5) and remove the radiator grille.
- Clean the radiator fins.
- Check the radiator and the cooling fluid hoses for leak tightness.
- Tighten clips at leaking hose connections.
- Check whether the leakage has been eliminated. If not, notify the authorised service centre.
- Fit the radiator grille and tightly screw on the radiator grille.

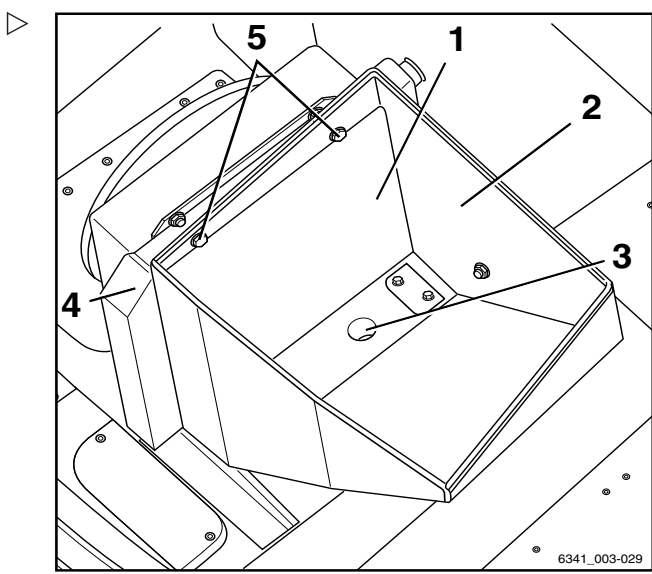

**i** NOTE

Make sure that the radiator grille is screwed tightly into place.

- Fit the rear cover.
- Fit the cover on the left-hand side.

Preserving operational readiness

Checking the battery condition, acid level and acid density

- Remove the battery from the truck.

⚠ DANGER

Risk to life!

- Observe the chapter entitled "Safety regulations when handling the battery".



⚠ WARNING

The electrolyte (diluted sulphuric acid) is poisonous and corrosive!



- Observe safety regulations for handling battery acid; see the chapter entitled "Battery acid".
- Wear personal protective equipment (rubber gloves, apron and protection goggles).
- Rinse away spilt battery acid immediately using plenty of water!

⚠ CAUTION

Damage to the battery possible!

- Follow the information in the operating instructions for the battery.

The battery must be removed for servicing; if necessary, change the truck battery.

- Keep away from open flames and do not smoke.
- Always ensure adequate ventilation in the vicinity.
- Expose the surfaces of the battery cells.
- Do not place any metal objects on the battery.
- Inspect battery for cracked housing, raised plates and acid leaks.
- Have defective batteries repaired by the authorised service centre.

Maintenance

5

Preserving operational readiness

- Open filler cap (1) and check the acid level. ▷

For batteries with "caged cell plugs", the liquid must reach the bottom of the cage.

For batteries without "caged cell plugs", the liquid must reach a height of approx. 10 to 15 mm above the lead plates.

- Top up low fluid with distilled water only.
- Immediately rinse away any spilled battery acid with plenty of water.
- Clean the battery cell cover and dry if necessary.
- Remove any oxidation residue on the battery terminals and battery terminal clips and grease them with acid-free grease.
- Tighten the battery-terminal clips (2) to a torque of 22 - 25 Nm (depending on the size of the terminal screws used).
- Check the acid density using an acid siphon.

After charging, this value must lie between 1.28 - 1.30 kg/l.

For a discharged battery, the acid density must **not be less** than 1.14 kg/l.

- Close the filler cap (1) again.

When using PowerPlusLife® batteries:

- Make sure that when cleaning or when filling up with liquid none of the liquid flows into the cooling channels.
- Check the cooling air inlet and cooling air outlet for dirt and remove any dirt that is present.

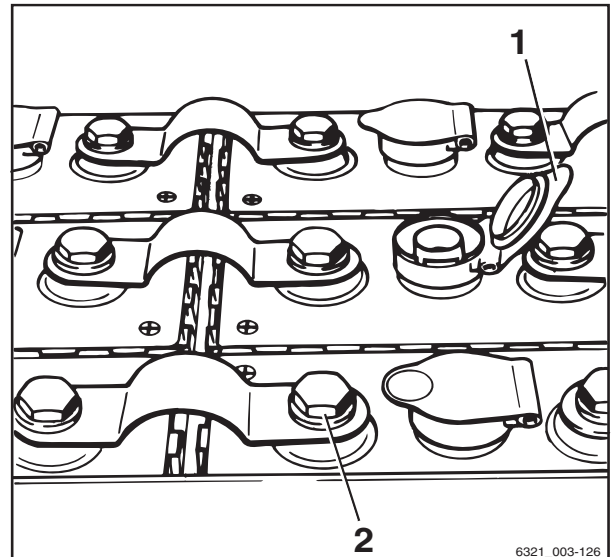

Changing the heating system fresh air filter

The fresh air filter for the heating system is on the right on the exterior of the cab.

5 Maintenance

Preserving operational readiness

- Loosen the quick-release clamp (1) by turning it and remove the cover (2).

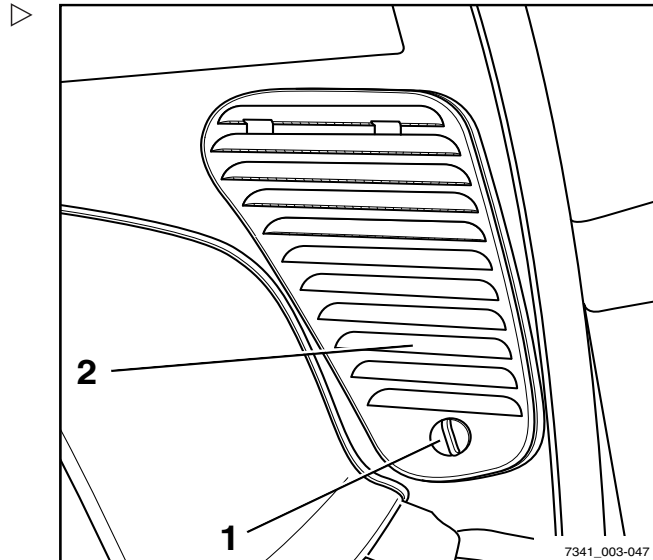

- Grasp the filter insert (3) at the finger opening (4) and remove it completely from the filter housing.
- Check the filter insert for contamination and beat out.

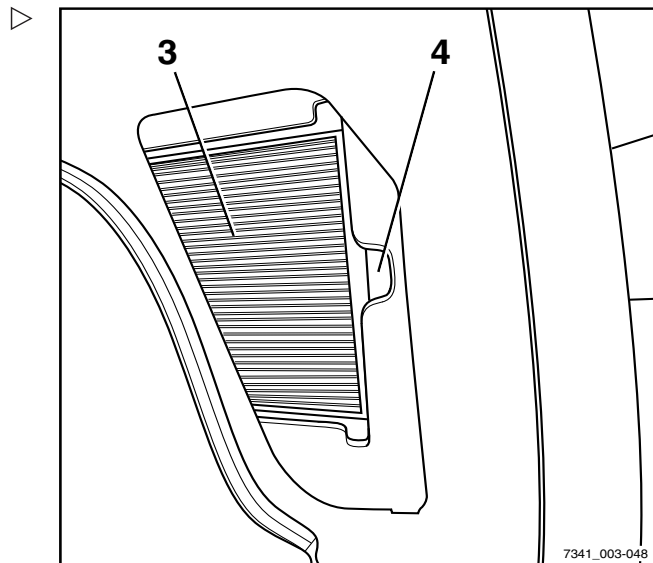

i NOTE

Replace the filter insert when it is clearly grey, but at least every two months.

- Remove pollution present in the filter housing and fresh-air inlet.
- Insert the filter insert back into the filter housing.
- Ensure that the filter insert sits correctly and precisely in the filter housing.
- Attach the cover and lock the quick-release clamp.

Lubricating the joints and controls

- Oil or grease other bearings and joints according to the maintenance data table.
- Driver's seat guide
- In the cab, lubricate door hinges at the lubricating nipple (variant)
- Battery door hinges or battery cover hinges
- Lubricate shafts and joints in dual-pedal operation (variant)

Maintaining the seat belt

⚠ DANGER

There is a risk to life if the seat belt fails during an accident!

If the seat belt is faulty, it may tear or open during an accident and no longer keep the driver in the driver's seat. The driver may therefore be hurled against the truck components or out of the truck.

- Ensure operational reliability by continually testing.
- Do not use a truck with a defective seat belt.
- Only have a defective belt replaced by your service centre.
- Only use genuine spare parts.
- Do not make any changes to the belt.

i NOTE

Carry out the following checks on a regular basis (monthly). In the case of significant strain, a daily check is necessary.

Checking the seat belt

- Pull out the belt (3) completely and check for wear. ▷

The belt must not be frayed or cut. The stitching must not be loose.

- Check whether the belt is dirty.
- Check whether parts are worn or damaged, including the attachment points.
- Check the buckle (1) to ensure that it locks in properly.

When the belt tongue (2) is inserted, the belt must be held securely.

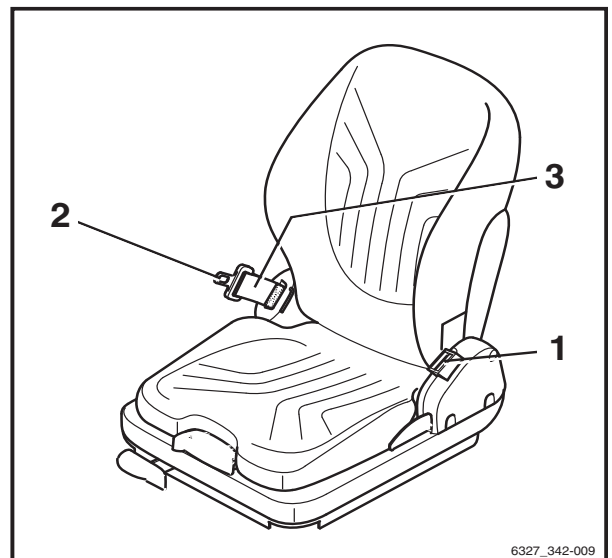

6327_342-009

5

Maintenance

Preserving operational readiness

- The belt tongue (2) must release when the red button (4) is pressed.
- The automatic blocking mechanism must be tested at least once a year:
- Park the forklift truck on level ground.
- Pull out the belt with a jerk.

The automatic blocking mechanism must block extension of the belt.

- Tilt the seat at least 30 ° (if necessary, remove the seat).
- Slowly extend the belt.

The automatic blocking mechanism must block extension of the belt.

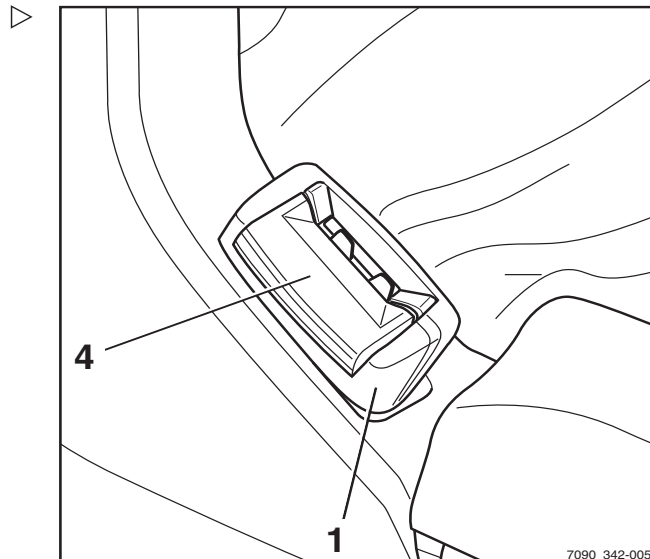

Cleaning the seat belt

- Clean the seat belt as necessary, but without using chemical cleaning materials (a brush will suffice).

Replacement after an accident

As a rule, the seat belt must be changed after an accident.

Checking the driver's seat

⚠ WARNING

Risk of injury!

- After an accident, check the driver's seat with attached restraining belt and fastening.
- Check the controls for correct operation.
- Check the condition of the seat (e.g. wear on the upholstery) and secure fastening to the hood.

⚠ WARNING

Risk of injury!

- Have the seat repaired by the service centre if you identify any damage during the checks.

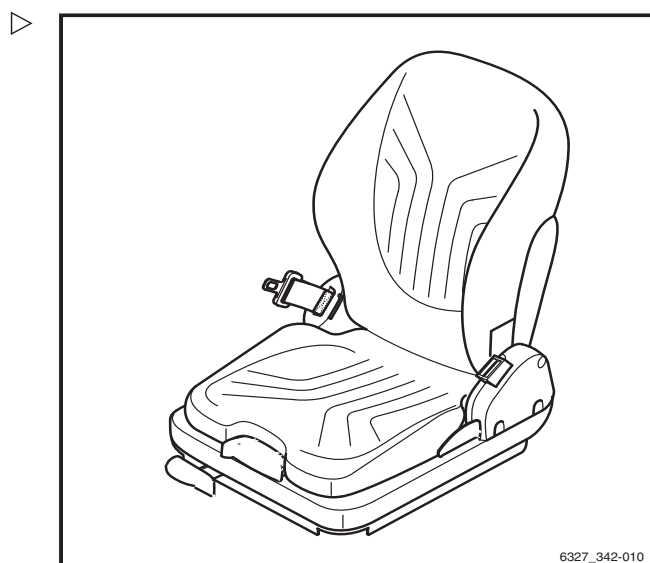

Checking the door latch

- Inspect the condition of the catch bolt and check for wear.
- Check the lock mechanism for easy operation.

Replacing the recirculated air filter for the heating system

The recirculated air filter for the heating system is located on the right-hand side of the cab, underneath the heating system panelling (1).

- Unscrew the screws (2) and remove the heating system panelling.
- Completely remove the filter mat (3) from the filter housing.
- Check the filter mat for contamination and beat out.

NOTE

Replace the filter mat when it is clearly grey, but at least every two months.

- Remove any dirt that has collected in the filter housing and recirculated-air inlet.
- Re-insert the filter mat into the filter housing.
- Make sure that the filter mat sits correctly and accurately in the filter housing.
- Attach the heating system panelling and secure tightly in place using the screws.

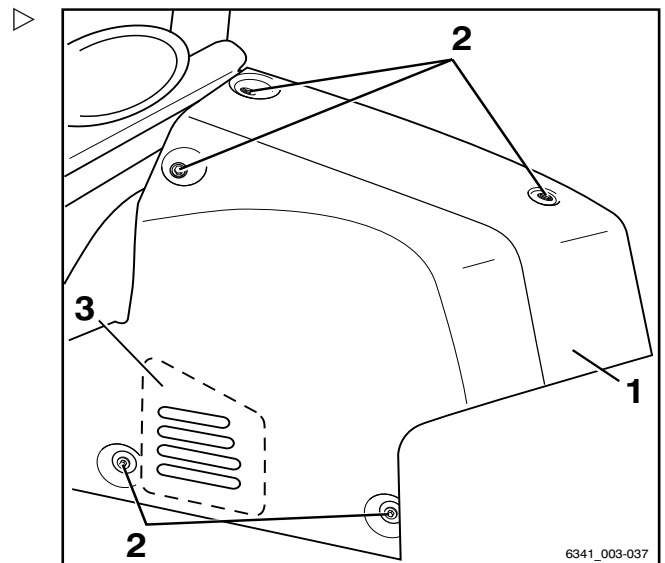

6341_003-037

Preserving operational readiness

Servicing wheels and tyres

⚠ WARNING

Risk of accident!

Uneven wear reduces the stability of the truck and increases the braking distance. The level of wear exhibited by tyres on the same axle must be approximately the same.

- Worn or damaged tyres (left or right) must be replaced immediately.
- When changing wheels or tyres, ensure that this does not cause the truck to tilt to one side (e.g. always replace right-hand and left-hand wheels at the same time).
- Changes must only be made following consultation with the manufacturer.

⚠ WARNING

Risk to stability!

Tyre quality affects the stability of the truck. There is a risk of tipping!

When using pneumatic tyres or solid rubber tyres, rim wheel parts must never be changed and rim wheel parts from different manufacturers must not be mixed.

- Obtain approval from the truck manufacturer before using a different type of tyre or a different tyre manufacturer.

Checking condition and wear of the tyres

Superelastic tyres (variant)

- Check the remaining distance between the tyre tread and the (60 J) wear mark.

Super-elastic tyres (variant) can be worn down to the (60 J) wear mark.

- Remove any foreign bodies embedded in the tyre.

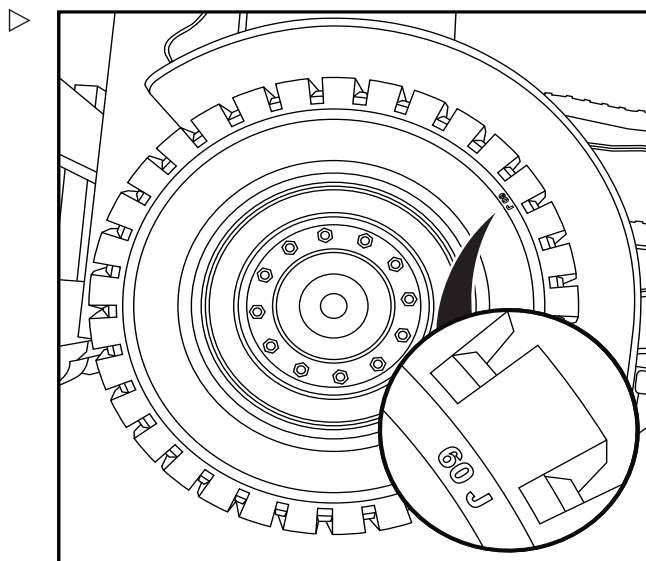

Pneumatic tyres (variant)

- Check the tread depth on all four tyres.

The tread depth for pneumatic tyres (variant) must be **at least 1.6 mm** at every point on the tread. If the tread is worn down to the wear mark (2) at any point on the tyre, replace the tyres on one axle.

- Remove any foreign bodies embedded in the tyre.

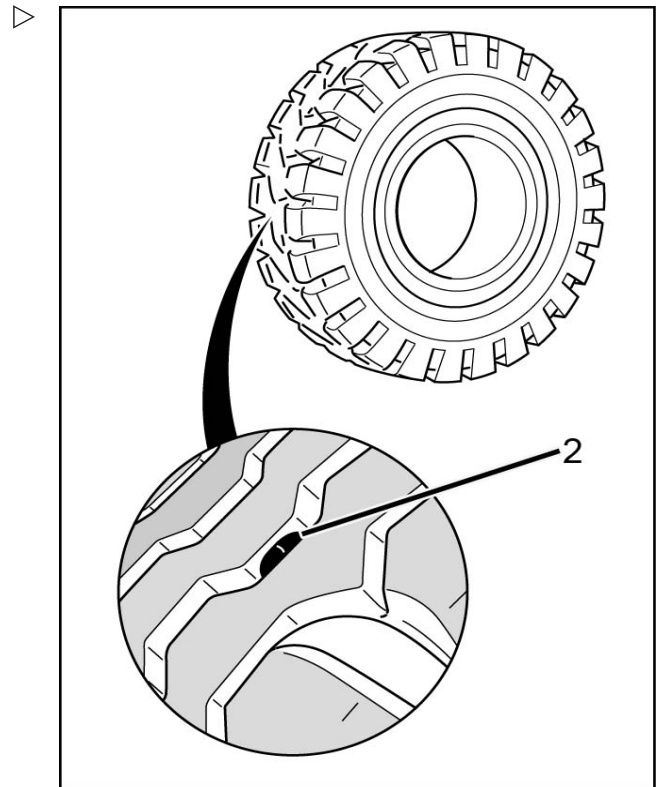

Checking the air pressure

i NOTE

The correct air pressure for pneumatic tyres (variant) is determined by the type of tyre used. The air pressure measured must correspond to the manufacturer's information.

- Observe the air pressure value indicated on the adhesive label (1) on the truck.
- Check the air pressure of all four tyres and compare with the air pressure values stated on the adhesive labels.
- Add or release air as required if the air pressure deviates from the values stated.

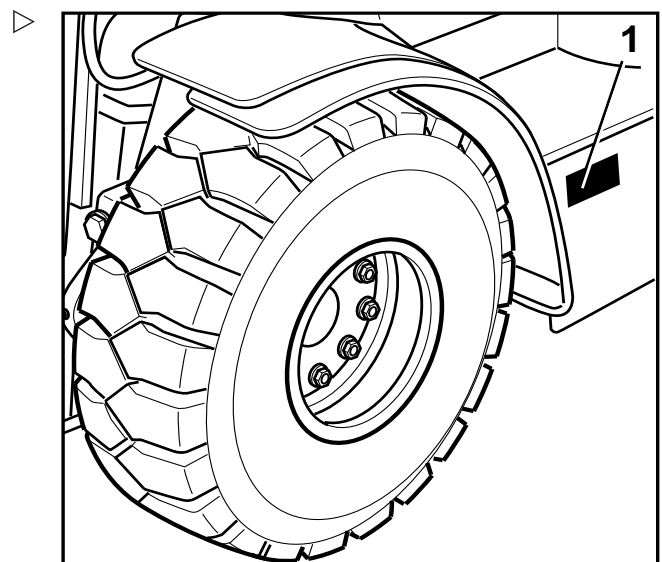

5 Maintenance

Preserving operational readiness

Checking wheel fastenings

- Check that all wheel fastenings (4) are securely fastened and retighten as necessary.
- Observe the relevant torques; see section entitled "Maintenance data table".

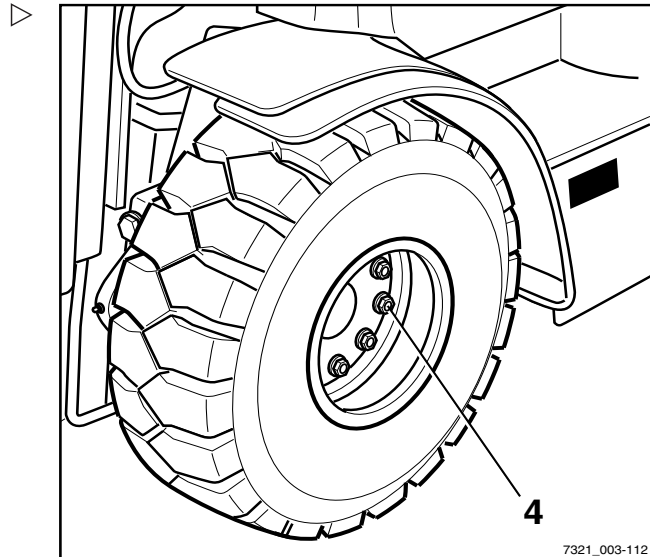

Replacing the fuses

⚠ DANGER

Risk of fire and risk of injury!

The truck must be de-energised before any work is carried out on the electrical system. Electric shocks can result in injuries and cause fires in the electrical system. There is also a risk of fire if fuses are bridged or repaired. Fuses with the wrong nominal current can cause short circuits.

- Park the truck securely and de-energise.
- Do not bridge or repair fuses.
- Use only fuses with the prescribed nominal current, see the chapter entitled "Fuse assignment".
- See the chapter entitled "Working on the electrical equipment".

i NOTE

The electrical fuses for the truck are located in two separate fuse boxes.

Front fuse box Power distribution unit and 80-V technology

The fuses for the power distribution unit and the 80-V consumers are located in the front fuse box (1).

- De-energise the truck.
 - Determine the cause of the short circuit or overload and eliminate it. Notify the authorised service centre as necessary.
 - Open the front right cover.
-
- Open the cover fastenings (1) and remove the cover.
 - Replace the defective fuse with nominal current according to "Fuse assignment - front fuse box".
 - Close the cover to secure the fuse box.
 - Close the front right cover.
 - Perform a function check. If the error persists or if the fuse is still defective, notify your authorised service centre.

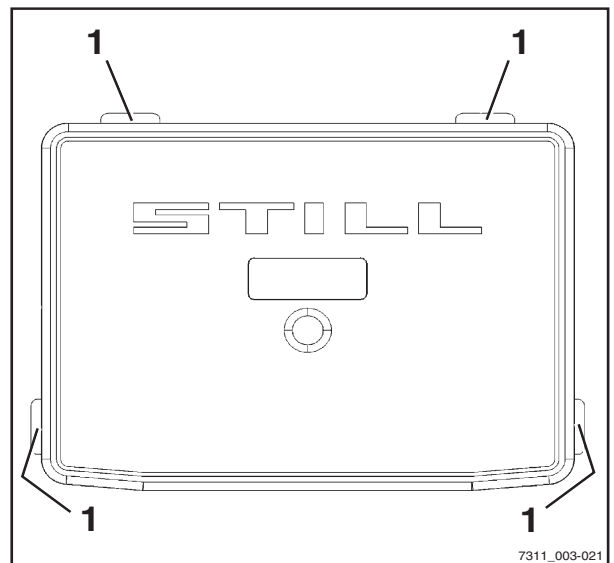
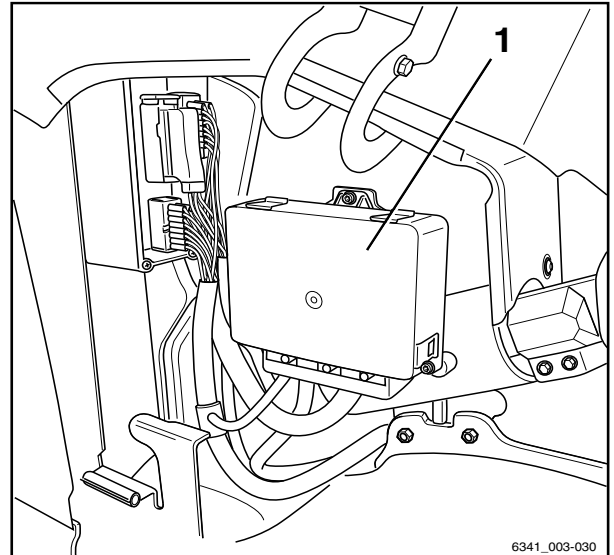

5 Maintenance

Preserving operational readiness

**Rear fuse box
12-V technology**

The fuses for the 12-V consumers are located in the rear fuse box (1).

- De-energise the truck.
 - Determine the cause of the short circuit or overload and eliminate it. Notify the authorised service centre as necessary.
 - Remove the left side cover.
-
- Open the cover fastenings (1) and remove the cover.
 - Replace the defective fuse with nominal current according to "Fuse assignment - rear fuse box".
 - Close the cover to secure the fuse box.
 - Attach the left side cover.
 - Perform a function check. If the error persists or if the fuse is still defective, notify your authorised service centre.

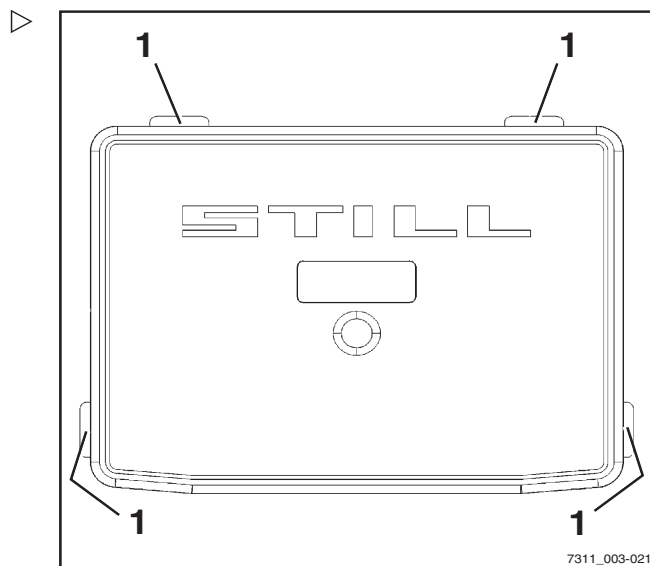
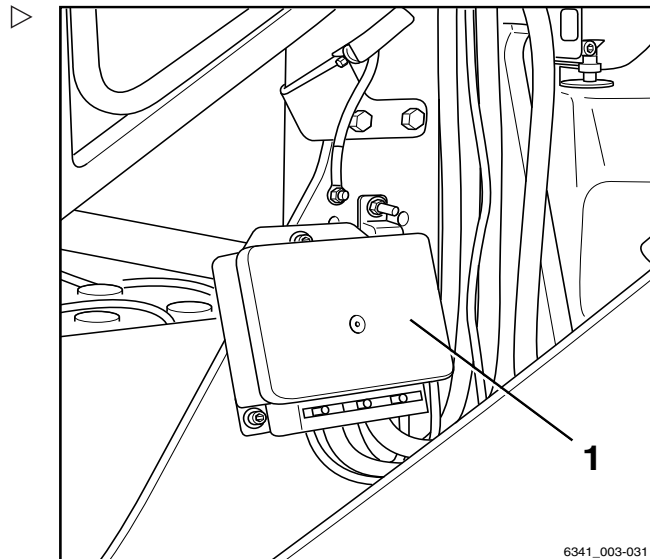

Checking the hydraulic oil level

⚠ CAUTION

Hydraulic oils are hazardous to health and are pressurised during operation.

- Note the safety regulations in the "Hydraulic fluid" chapter.
-
- Park the truck securely.
 - Remove the left side cover.

Maintenance

5

Preserving operational readiness

- Unscrew breather filter (1).

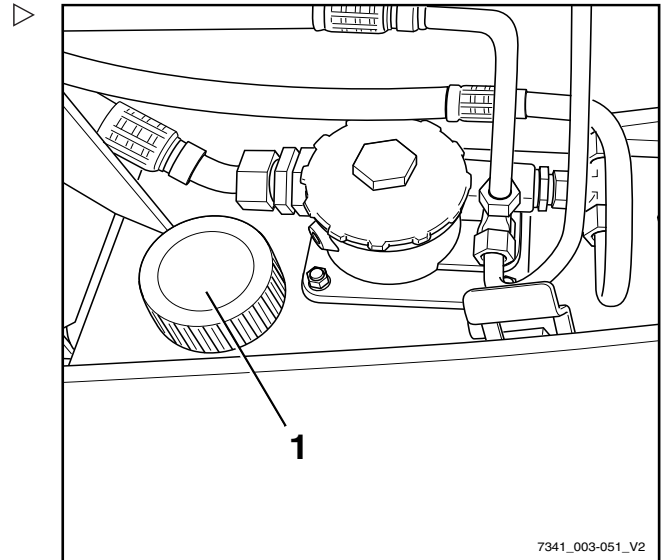

The lower mark, (1) or (2), indicates the minimum filling level. The top mark, (max), indicates the maximum filling quantity.

The lower mark that is applicable for the specific truck depends on the lift mast, the relevant lift height (see table below) and the resulting filling quantities.



Lower mark	Lift height [mm]			
	6 t		7 t/8 t	
	Telescopic	Triplex	Telescopic	Triplex
1	3550 - 6849	-	3550 - 5249	4205 - 4654
	6850 - 8449	4770 - 5819	5250 - 6449	4655 - 5704
2	8450 - 8850	5820 - 9270	6450 - 8850	5705 - 9755

- Determine which lift mast is fitted to the truck.
- Use the table to determine which lower mark, (1) or (2), is applicable.
- Check the oil level on the oil dipstick.

The oil level must be between the lower mark, (1) or (2), and the top mark, (max).

If the oil level is too low:

- Insert a funnel into the filler neck.

5 Maintenance

Preserving operational readiness

- Add hydraulic oil with the correct specification according to the maintenance data table.
- Top up the hydraulic oil only as far as the top (max) mark.

ENVIRONMENT NOTE

Carefully collect any spilled oil and dispose of it in an environmentally friendly manner.

- Screw in the breather filter with oil dipstick.
- Attach the left side cover.

WARNING

If the hydraulic oil level is too high, it can lead to inadmissibly high pressure and damage to the hydraulic system.

- If the oil level is higher than the top (max) mark, lower the hydraulic oil level.
- Contact the authorised service centre if required.

Checking the hydraulic system for leak tightness



WARNING

Hydraulic oil is hazardous to health!
Hydraulic oil under pressure can escape from leaking pipes and lines, and cause injuries.

- Wear suitable protective gloves, protection goggles etc.

CAUTION

Hydraulic hoses become brittle!

- Do not store hydraulic hoses for more than two years.
- Do not use hydraulic hoses for more than six years if they are subject to normal wear.
- Do not use hydraulic hoses for more than two years if they are subject to a high level of wear.
- Comply with the specifications of DGUV 113-020 in Germany.
- Outside of Germany, observe the national regulations for the country of use.

- Check pipe and hose connection screw joints for leaks (traces of oil).

Replace hose lines if they display the following abnormalities:

- Outer layer has been damaged, or is brittle or cracked
- Leaking
- Deformation (e.g. with blisters or kinks)
- A fitting has come loose
- A fitting is badly damaged or corroded

Replace pipes if they display the following abnormalities:

- Abrasion
- Deformation and bending
- Leaking

Lubricating the lift mast and roller track

- Remove dirt and lubricant residue from the roller track.
- Lubricate the roller tracks (1) of the outside, middle, and inside mast with a super-pressure adhesion lubricant to reduce wear. See ⇒ Chapter "Maintenance data table", P. 5-325.

i NOTE

Spray the roller track evenly from a distance of approx. 15-20 cm. Wait approx. 15 minutes until the equipment is ready to use again.

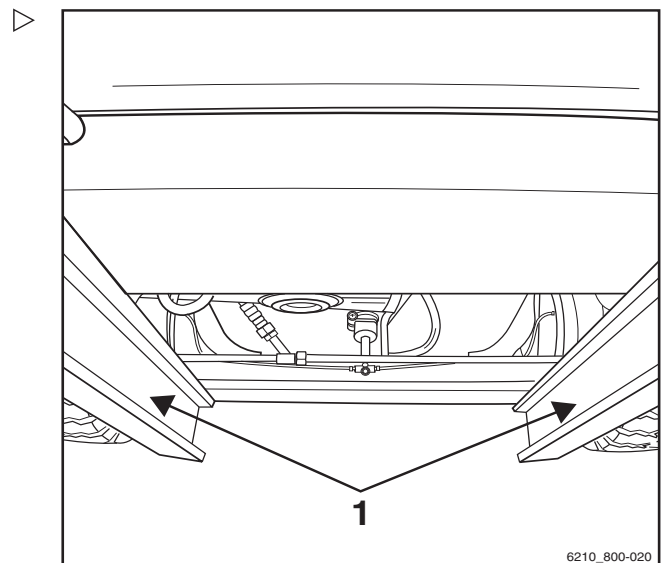

Greasing the automatic tow coupling

i NOTE

Wear to moving parts can be significantly reduced by appropriate servicing and regular lubrication of the coupling.

- Avoid over-greasing!

5 Maintenance

Preserving operational readiness

i NOTE

Close the coupling before cleaning with a high-pressure cleaner. After cleaning, lubricate the coupling pin, tow bar eye and its supporting surface again.

Model RO*243

- Pull out the safety handle (3).
- Push the hand lever (2) upwards.
- Grease using the lubricating nipple(1) in accordance with the maintenance data table; see ⇒ Chapter "Maintenance data table", P. 5-325.
- Close the coupling by raising the coupling pin with a suitable tool.
- For journeys with a rigid drawbar trailer, lubricate the underside of the tow bar eye and the supporting surface on the coupling.

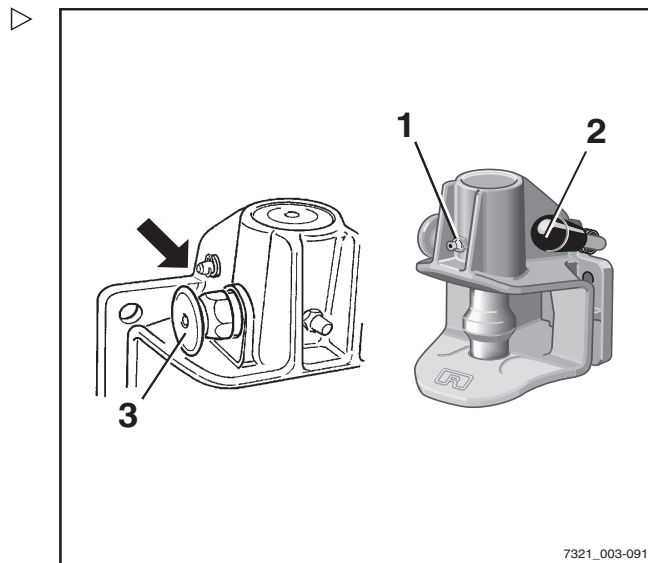

- Determine the wear on the coupling pin.
- The diameter of the spherical part must not be less than 36.5 mm.

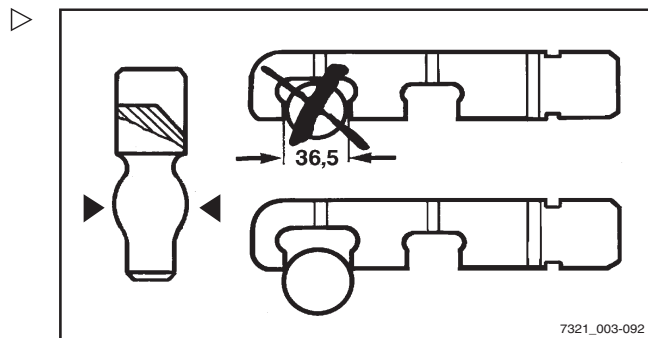

Model RO*244 A

- Open coupling.

- Grease using the lubricating nipple(1) in accordance with the maintenance data table; see ⇒ Chapter "Maintenance data table", P. 5-325.
- Grease coupling pin, tow bar eye and its supporting surface.

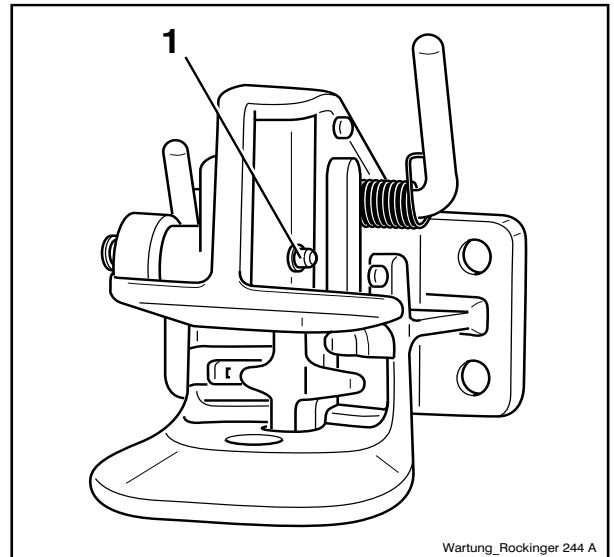

Model RO*245

- Lubricate via the points provided for this purpose (lubricating nipple, opened coupling) in accordance with the maintenance data table; see ⇒ Chapter "Maintenance data table", P. 5-325.
- Grease the supporting surface for the tow-bar eye.

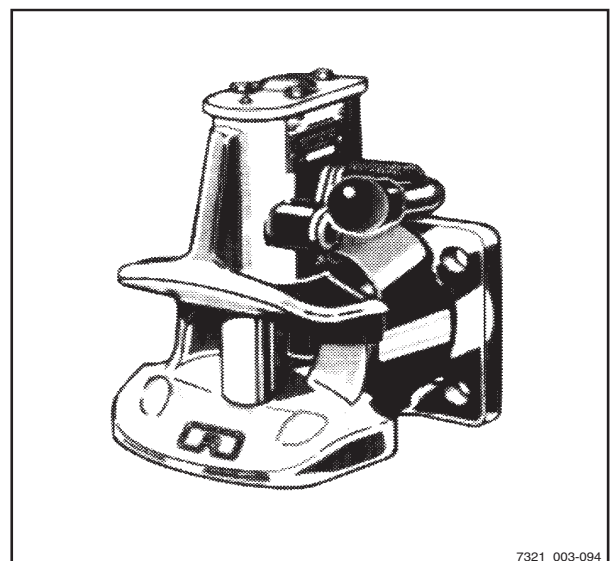

5 Maintenance

Preserving operational readiness

Model RO*841

- Lubricate via the points provided for this purpose (lubricating nipple, opened coupling) in accordance with the maintenance data table; see ⇒ Chapter "Maintenance data table", P. 5-325.
- Grease the supporting surface for the tow-bar eye.

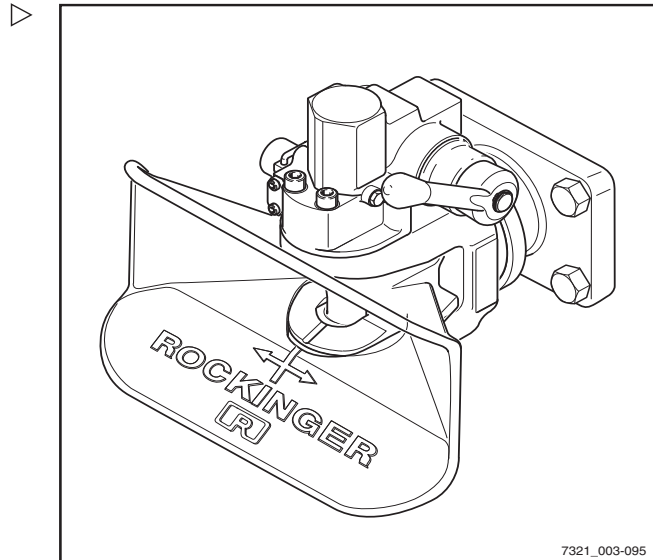



6

1000-hour maintenance/annual maintenance

6 1000-hour maintenance/annual maintenance

Other tasks

Other tasks

- Perform all tasks required to maintain full operability; see the chapter entitled "Remaining ready for operation".

Checking the lift cylinders and the hydraulic connections for leak tightness

⚠ WARNING

Risk of injury!
Observe safety regulations for working on the lift mast, see the "Working at the front of the truck" chapter.

- Check the lift cylinders and the hydraulic connections for leak tightness (visual inspection).
- Have any leaking lift cylinders and hydraulic connections repaired by the authorised service centre.

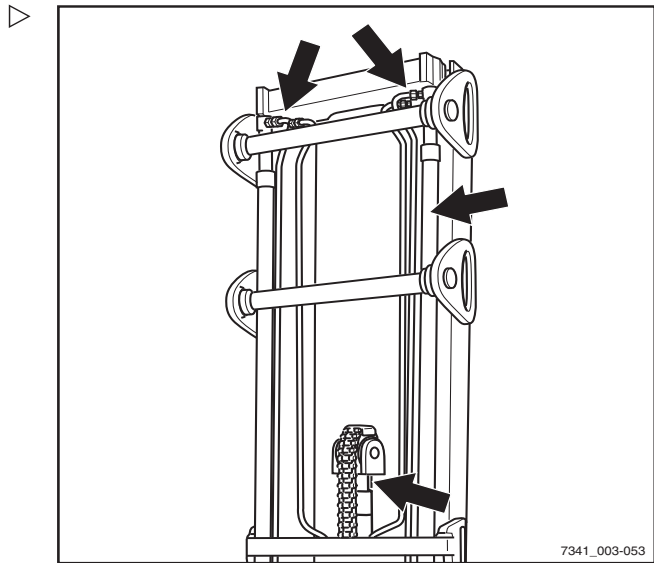

Checking the fork arms

⚠ CAUTION

Fork arms must not be uneven!
- Always replace both fork arms.

- Check the fork arms (1) for visible deformation and excessive wear.

No cracks or deformations must be visible on the fork arms in the area around the fork bend. Wear must not amount to more than 10% of the original thickness.

- Check that the locking screws (2) are present and securely attached.
- Replace any worn or deformed fork arms.

Check the condition and correct operation of the fork latch:

- Move the locking lever (3) into a vertical position.

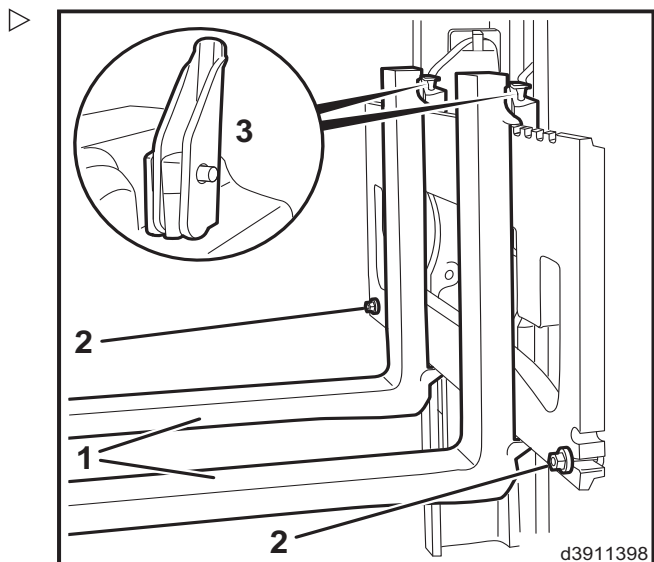

It must be possible to move the fork arm.

- Move the locking lever into a horizontal position.

The latch must engage in a recess on the fork carriage. It must not be possible to move the fork arm.

- Replace faulty fork latches.

Checking the reversible fork arms

NOTE

This check is only required for reversible fork arms (variant).

- Check the outside of the fork bend (1) for cracks. Contact your service centre.

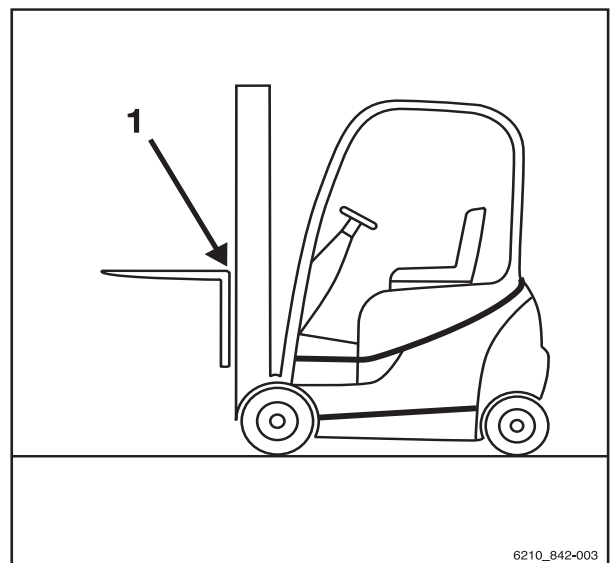

6210_842-003



6 1000-hour maintenance/annual maintenance
Checking the reversible fork arms



7

Technical data

7 Technical data

Dimensions

Dimensions

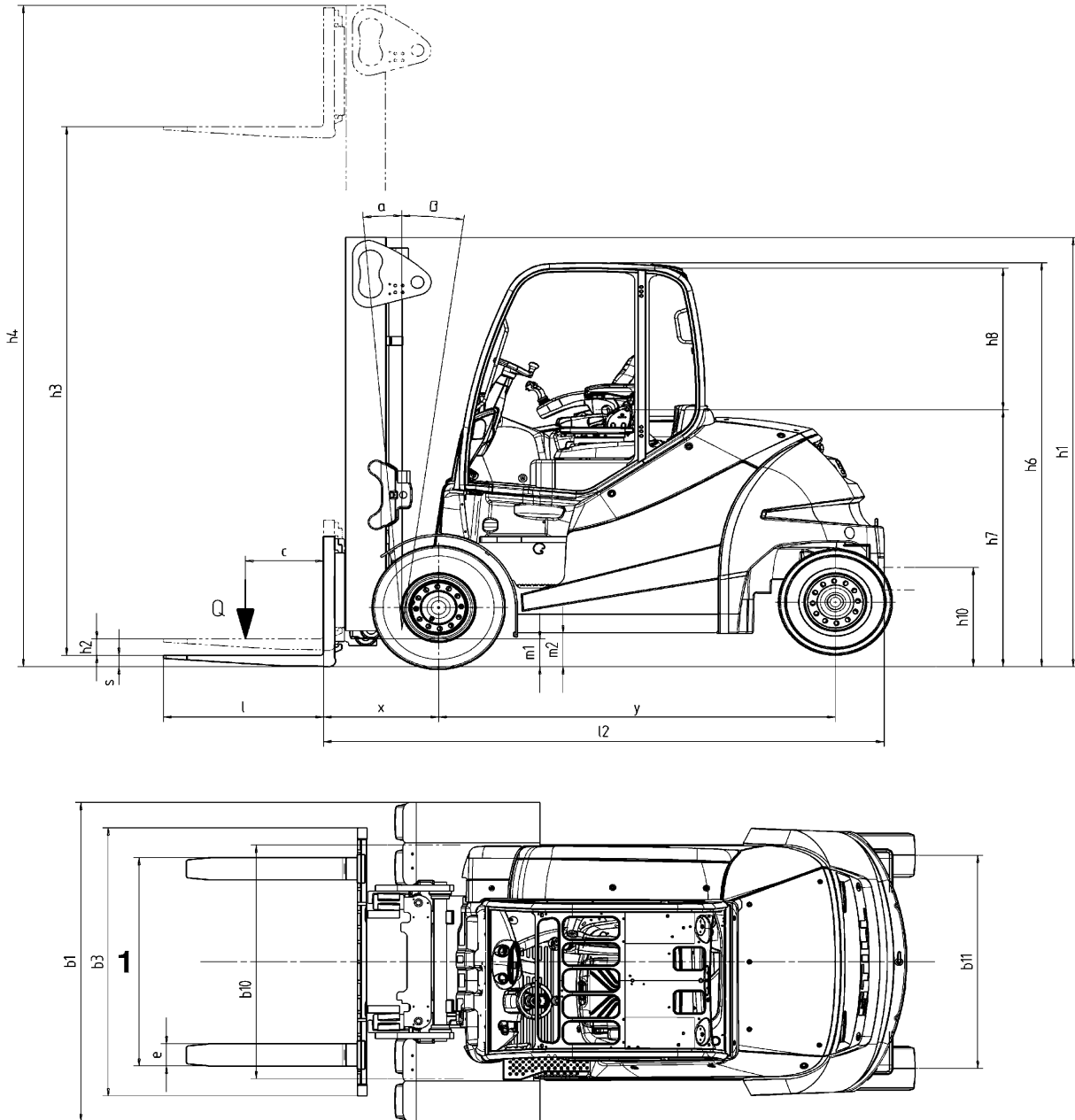

6341_003-022

1 Fork spacing is adjustable

i NOTE

Measurements h_1 , h_3 , h_4 , h_6 and b_1 are customised and can be taken from the order confirmation.



Technical data

7

Dimensions

Centre of gravity "S" (distance measured from the front axle)

RX60-60	1006 mm
RX60-70	1006 mm
RX60-80	1006 mm
RX60-80 (LSP 900)	1006 mm

 **NOTE**

The specified centre of gravity "S" relates to trucks with standard equipment. If, for example, the truck is equipped with a different lift mast, attachment or driver protection structure, this value is only a guide value. If necessary, the centre of gravity "S" must be determined on an individual basis for each truck.

VDI datasheet

VDI datasheet

i NOTE

This VDI datasheet specifies only the technical values of the truck version with standard equipment. Different tyres, lift masts, additional units etc. may produce different values.

Characteristics

Model		RX60-60	RX60-70	RX60-80	RX60-80 LSP 900
Type carrier		6341	6342	6343	6344
Manufacturer		STILL GmbH	STILL GmbH	STILL GmbH	STILL GmbH
Drive		Electric	Electric	Electric	Electric
Operation		Seated	Seated	Seated	Seated
Rated capacity / load	Q (kg)	6000	7000	8000	8000
Load centre of gravity distance	c (mm)	600	600	600	900
Load distance	x (mm)	710	720	720	750
Wheelbase	y (mm)	2285	2285	2285	2285

Weights

Model		RX60-60	RX60-70	RX60-80	RX60-80 LSP 900
Net weight	kg	11,996	12,512	13,369	15,915
Axle load with front load	kg	15,842	17,751	19,355	21,549
Axle load with rear load	kg	2154	1761	2015	2366
Axle load without front load	kg	6413	6591	6627	7097
Axle load without rear load	kg	5619	5823	6655	8333

Technical data

7

VDI datasheet

Wheels, chassis frame

Model		RX60-60	RX60-70	RX60-80	RX60-80 LSP 900
Tyres: superelastic (SE), solid rubber (V), pneumatic (L)		SE	SE	SE	SE
Front wheel size		355/50-20	8.25-15	315/70-15	315/70-15
Rear wheel size		250-15	250-15	250-15	28x12.5-15
Number of front wheels (x = driven)		2x	4x	4x	4x
Number of rear wheels (x = driven)		2	2	2	2
Front track width, single tyre	b10 (mm)	1364	-	-	-
Front track width, twin tyres		-	1510	1561	1561
Rear track width	b11 (mm)	1358	1358	1358	1432

Basic dimensions

Model		RX60-60	RX60-70	RX60-80	RX60-80 LSP 900
Lift mast/fork carriage tilt, forwards	Degree	5	5	5	5
Lift mast/fork carriage tilt, backwards	Degree	8	8	8	8
Height with lift mast retracted	h1 (mm)	2710	2710	2710	2710
Free lift	h2 (mm)	150	150	150	150
Lift height ¹	h3 (mm)	3550	3150	3150	2750
Height with lift mast extended	h4 (mm)	4440	4240	4140	4140
Height above overhead guard	h6 (mm)	2697	2697	2697	2697
Seat height in relation to SIP/standing height	h7 (mm)	1719	1719	1719	1719
Coupling height	h10 (mm)	520/670	520/670	520/670	520/670
Total length	l1 (mm)	4640	4660	4660	5335
Length including fork back	l2 (mm)	3440	3460	3460	3535
Total width	b1	1679	1996	1996	2141

¹ The specified lift takes into account the tyre deflection and the tolerances of the tyre diameter.



7

Technical data

VDI datasheet

Model		RX60-60	RX60-70	RX60-80	RX60-80 LSP 900
Fork arm thickness	s (mm)	70	70	70	70
Fork arm width	e (mm)	150	150	150	200
Fork arm length	l (mm)	1200	1200	1200	1200
Fork carriage, class/form A, B		ISO IV A	ISO IV A	ISO IV A	ISO IV A
Fork carriage width	b3 (mm)	1600	1800	1800	2180
Ground clearance with load under lift mast	m1 (mm)	220	220	220	220
Ground clearance at centre of wheelbase	m2 (mm)	210	210	210	210
Aisle width for pallet 1000 x 1200 crosswise	Ast (mm)	4907	4907	4907	4999
Aisle width for pallet 800 x 1200 lengthwise	Ast (mm)	5107	5107	5107	5199
Turning radius	Wa (mm)	3007	3007	3007	3049
Smallest pivot point distance	b13 (mm)	877	877	877	877

Performance data

Model		RX60-60	RX60-70	RX60-80	RX60-80 LSP 900
Driving speed with load	km/h	14	14	14	14
Driving speed without load	km/h	17	17	17	17
Lifting speed with load	m/s	0.36	0.30	0.28	0.28
Lifting speed without load	m/s	0.48	0.37	0.37	0.37
Lowering speed with load	m/s	0.56	0.53	0.53	0.53
Lowering speed without load	m/s	0.52	0.42	0.42	0.42
Tractive force with load	N	28788	28674	28468	27997
Tractive force without load	N	29023	28936	28767	28295
Climbing capability ² with load	%	16.3	16.1	16.0	15.5
Climbing capability without load	%	25.0	24.1	23.0	>22.5
Acceleration time with load (15 m)	s	5.7	5.8	5.8	6.0
Acceleration time without load (15 m)	s	5.0	5.1	5.1	5.2
Service brake		Mech./hydr.	Mech./hydr.	Mech./hydr.	Mech./hydr.

² The stated values are used only to compare performance of trucks in the same category. The gradient values in no way represent the normal daily operating conditions.

Technical data

7

VDI datasheet

⚠ CAUTION

To use the truck safely—with or without a load—the maximum ascending or descending gradient permitted for travel is 15%.

- If you have any questions, please contact the authorised service centre.

Electric motor

Model		RX60-60	RX60-70	RX60-80	RX60-80 LSP 900
Traction motor, power rating at S2: 60 min	kW	2x10.5	2x10.5	2x10.5	2x10.5
Lift motor, power rating at 15% ED	kW	2x21.0	2x21.0	2x21.0	2x21.0
Battery in accordance with DIN 43531/35/36 A, B, C		DIN 43536 A	DIN 43536 A	DIN 43536 A	DIN 43536 A
Battery voltage	U (V)	80	80	80	80
Battery capacity	K ₅ Ah	1240	1240	1240	1240
Battery weight	kg	2824	2824	2824	2824
Energy consumption ³ : 45 VDI working cycles/hour	kWh/h	12.6	14.5	16.0	17.7
Handling performance	t/h	348.4	376.1	411.4	420.0
Energy consumption versus handling performance	kWh/h	15.4	17.5	19.2	19.8

Other

Model		RX60-60	RX60-70	RX60-80	RX60-80 LSP 900
Working pressure for attachments	bar	250	250	250	250
Oil flow for attachments	l/min	60	60	60	60
Sound pressure level L _{pAZ} (driver's compartment) ⁴	dB (A)	66.4	66.4	66.4	66.4
Sound power level L _{wAZ}	dB (A)	86.6	86.6	86.6	86.6
Human vibration acceleration ⁵ according to EN 13059	m/s ²	< 0.38	< 0.38	< 0.38	< 0.38
Tow coupling, type/model		Bolt	Bolt	Bolt	Bolt

³ With Blue-Q energy-saving programme.

⁴ Without cab. Values differ with a cab.

⁵ With a standard driver's seat.

Ergonomic dimensions

Ergonomic dimensions

⚠ WARNING

Danger of impact injuries to the head!

If the head of the operator is located too close to the underside of the roof, the suspension of the driver's seat or an accident may cause the head to strike the overhead guard.

To avoid head injuries, a minimum distance of **40 mm** must be ensured between the underside of the roof and the head of the tallest operator.

To determine the actual head clearance, the operator must sit in the driver's seat and the seat suspension must be set to this driver's requirements.

Due to the individual nature of height and body weight as well as the wide variety of types of driver's seat and overhead guard, the minimum head clearance must be ensured in every truck.

The driver's compartment has been designed taking ergonomics in the workplace into account and in accordance with EN ISO 3411. In general, from the seat position, the operator has sufficient space to reach the operating devices safely, to operate the truck and to view the outline of the truck. Operators whose body size deviates from the specified dimensions on which EN ISO 3411 is based must be individually considered by the operating company.

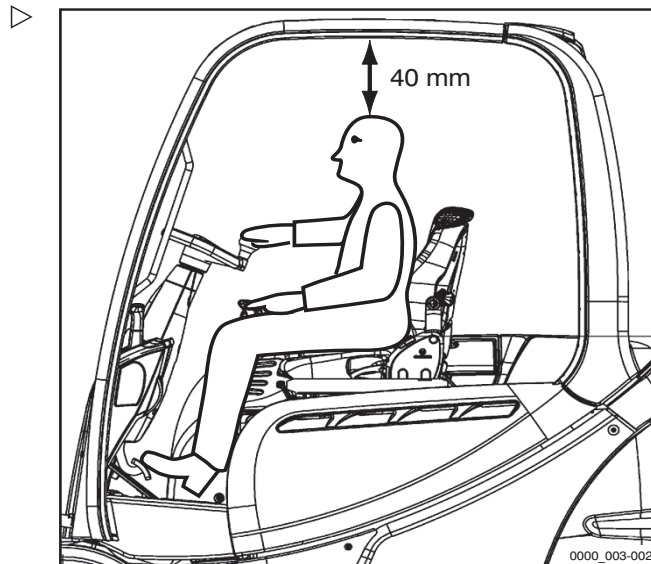

Battery specifications

⚠ CAUTION

The battery weight and dimensions affect the stability of the truck.

When replacing the battery, the weight ratios must not be changed. The battery weight must remain within the weight range specified on the nameplate. The location of ballast weights must not be changed. The bottom of the battery tray must be closed.

- Use batteries that meet DIN standards.
- Do not change the position of ballast weights.
- Check the battery weight against the information on the nameplate.
- Only use a battery tray that is closed at the bottom.

Lead-acid batteries

i NOTE

Battery specifications to DIN 43536; cells to DIN EN 60254-2, 80 V circuit A.

- The battery weight can be found on the nameplate of the battery.

Battery designation	Capacity (Ah)	Battery compartment dimensions (mm)			Tray
		Depth	Width	Height	
7 PzS 1085 PowerPlusLife [®]	1085	1037	1287	784	238
8 PzS 1120	1120	1037	1287	784	238
8 PzS 1240	1240	1037	1287	784	238
TENSOR [®] TCSM 2545	1320	1037	1287	784	238

i NOTE

When determining the weight, add the weight of the battery base frame (65 kg) to the battery weight.

i NOTE

The maximum speed pre-set in the drive programme is technically dependent on the battery used. Depending on the battery type used, the preset maximum speed must be



Battery specifications

adapted by the authorised service centre. If the maximum speed is not adapted, it can lead to technical faults in drive mode.

- *Contact your authorised service centre.*

Fuse assignment

i NOTE

The electrical fuses for the truck are located in two separate fuse boxes. Depending on the specification, not all fuses will be present in the truck.

Fuse assignment - Front fuse box Power Distribution Unit and 80-V technology

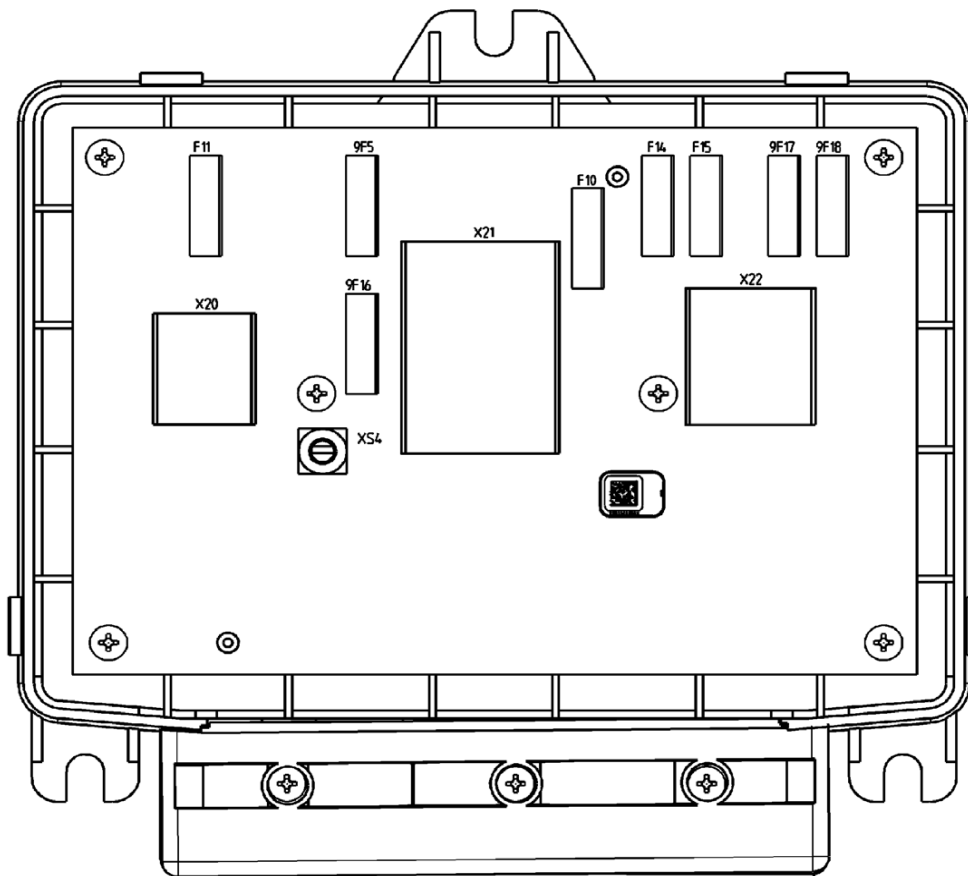

6341_003-027_V2

F11 SU control unit/MCU control unit (10 A)
 9F5 Not assigned
 9F16 Heating system (30 A)
 F10 Reserve (20 A)

F14 Not assigned
 F15 Voltage transformer U1 (10 A)
 9F17 Voltage transformers U2 and U3 (15 A)
 9F18 Voltage transformers U4 and U5 (15 A)

Fuse assignment

Fuse assignment - rear fuse box
12-V technology

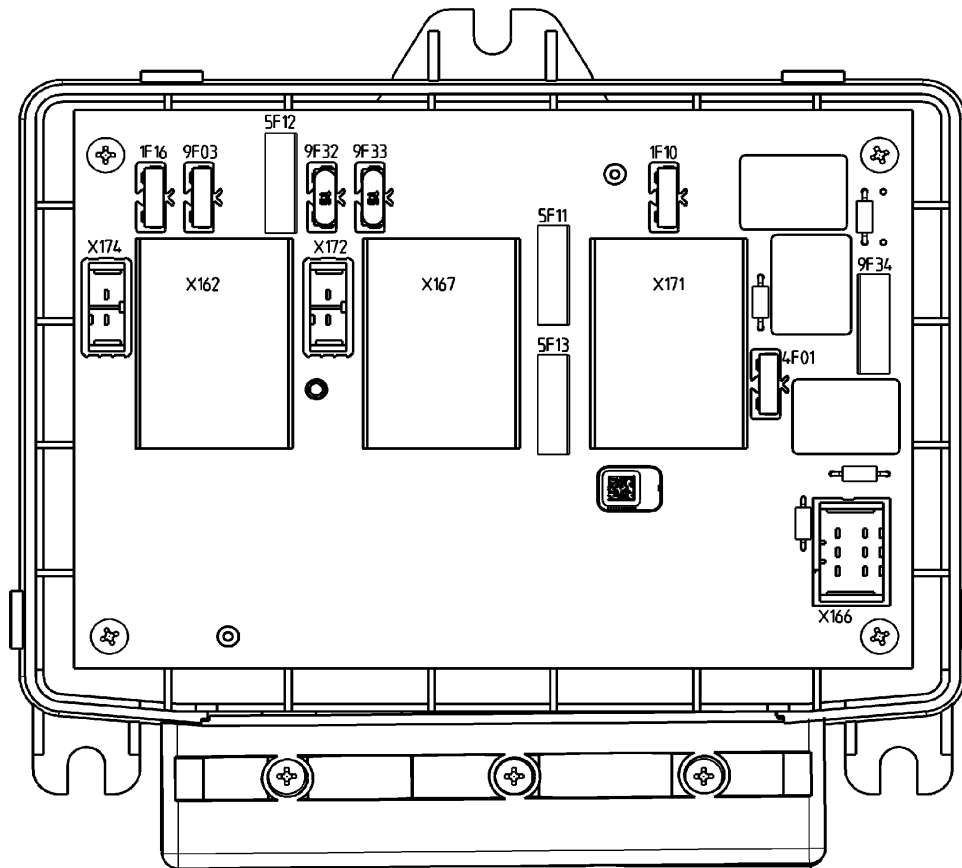

6341_003-028

1F16 Proportional technology (10 A)
9F03 Option board (10 A)
5F12 Front CPP - control unit (20 A)
9F32 Not assigned
9F33 Not assigned

5F11 Roof CPP - control unit (30 A)
5F13 Seat CPP - control unit (30 A)
1F10 Cooling pump (10 A)
4F01 Signal horn (10 A)
9F34 Cooling fan (20 A)



Index

NUMBERS AND SYMBOLS

12-V socket 221

A

Access authorisation

 Changing the password 102

 Defining the driver PIN 98

 Entering the access code 97

 Selecting the driver PIN 100

Access authorisation with PIN code 95

Accessories 7

Actuating the drive direction switch

 Fingertip version 130

 Joystick 4Plus version 130

 Mini-console version 131

 Mini-lever version 129

Address of manufacturer I

Adjusting the armrest 80

Adjusting the fork 173

Adjusting the steering column 81

After cleaning 289

Attachments

 Controlling using a double mini-lever 190

 Controlling using the double mini-lever and the 5th function . . . 192

 Controlling using the joystick 4Plus and the 5th function 203

 Controlling using the quadruple mini-lever and the 5th function . . . 200

 Controlling using the triple mini-lever and the 5th function . . . 196

 Controlling via the joystick 4Plus 202

 Controlling with a quadruple mini-lever 198

 Controlling with a triple mini-lever 194

 Controlling with fingertip 204

 Controlling with fingertip and 5th function 205

 Fitting 184

 General controlling 188

 Mounting 185

 Releasing the pressure from the connections 186

 Special risks 40

 Taking up a load 210

Automatic lift cut out 146

Automatic tow coupling 238

 Coupling RO*243 240

 Coupling RO*244 A 242

 Coupling RO*245 245

 Uncoupling RO*243 242

 Uncoupling RO*244 A 244

 Uncoupling RO*245 246



B	
Battery	
Changing the battery type	273
Charging	268
Charging to equalise	271
Checking the acid density	338
Checking the acid level	338
Checking the charge status	268
Checking the condition	338
Disposal	25
PowerPlusLife	282
Safety regulations	265
Battery acid	50
Battery cover	
Closing	275
Opening	274
Battery male connector	
Connecting	262
Disconnecting	263
Battery specifications	367
Before taking up load	168
Blue-Q	
Configure	116
Functional description	118
Switching off	119
Switching off additional consumers	119
Switching on	119
Bottom plate	
Installing	329
Removing	328
C	
Cab	
Operating the interior lighting	230
Operating the rear window heating	231
CE labelling	5
Ceiling sensor	222
Changes to the truck	31
Changing the drive direction	133
Dual pedal version	136
Changing the fork arms	161
Changing the heating system fresh air filter	339
Changing the password	102
Checking coolant content	333
Checking the door latch	343
Checking the driver's seat	342
Checking the emergency off function	90
Checking the fork arms	356
Checking wheel fastenings	346
Clamp locking mechanism	
Releasing	207
Cleaning the electrical system	288
Cleaning the truck	286
Cleaning the windows	289
Climbing into the truck	73
Climbing out of the truck	73
Clipboard	234
Closing the cab door	229
Closing the side windows	229
Commissioning	12
Condition of roadways	125
Consumables	48
Coolant and cooling fluid safety information	51
Disposal	52
Safety information for handling battery acid	50
Safety information for handling oils	48
Safety information for hydraulic fluid	49
Contact details	I
Coolant	
Checking the level	332
Coolant and cooling fluid	51
Cooling fluid	333
Topping up	333
Copyright and trademark rights	19
Coupling pin in the counterweight	236
Crane loading	304
Determining the loading weight	305
Hooking on the lifting straps	305
Curve Speed Control	141



Index

D

Damage 34

Danger area 173

Danger to employees 45

Declaration of conformity 6

Defects 34

Defining the driver PIN 98

Definition of directions 23

Description of the truck 2

Dimensions 360

Dimensions of roadways 123

Display and operating unit

 Additional indicators 107

 Adjusting the displays 107

 Configure Blue Q 116

 Indicators 105

Display messages

 Display content 247

 Drive-specific 259

 General 250

Display operating unit 61

 Resetting the daily kilometres 114

 Setting the date 114

 Setting the language 115

 Setting the time 114

 Standard displays 105

Display symbols 109

 Auxiliary equipment softkey functions 111

 Error messages 110

 Menu navigation softkey functions 112

 Numeric keypad 113

 Operating messages 109

 Status LEDs 112

 Warning messages 110

Display-operating unit

 Standard display elements 95

Disposal

 Battery 25

 Components 25

Documentation scope 17

Double mini-lever 63

 Lifting/lowering the fork carriage ... 155

 Tilting the lift mast 155

Driver rights, duties and rules of behaviour 29

Driver's cab

 Use 86

Drivers 29

Driving

 Ascending gradients 142

 Descending gradients 142

Driving lights

 Switching on and off 211

Driving on gradients 123

Driving on lifts 182

Driving on loading bridges 183

E

EC declaration of conformity in accordance with Machinery Directive 6

Emergencies

 Truck tipping over 293

 Using the emergency hammer 294

Emergency hammer 294

Emergency lowering 294

Emergency shutdown 291

Emissions 53

 Battery 55

 Noise emissions 53

 Vibrations 54

Entering the access code 97

Ergonomic dimensions 366

Error code table 247

Example 169

F

Filling the washer system 219

Fingertip 67

 Lifting/lowering the fork carriage ... 160

 Tilting the lift mast 160

Fitting attachments 184



FleetManager	220
Shock recognition	220
Fork arms	
Length	37
Fork extension	163
Four-way mini-lever	65
Lifting/lowering the fork carriage ...	157
Front right cover	
Closing	330
Opening	330
Fuse assignment	369
12-V technology	370
80-V technology	369
Front fuse box	369
Power distribution unit	369
Rear fuse box	370
Fuse box	
Front	347
Rear	348
G	
General	4
H	
Handling gas springs and accumulators .	37
Hazard areas	125
Hazard warning system	213
Hazards and countermeasures	42
Heating system	232
Adjusting the air flow	233
Switching on	233
Switching on the blower	233
Hydraulic blocking function	153
Releasing	153
Hydraulic connections	
Checking for leak tightness	356
Hydraulic fluid	49
Hydraulic system	
Checking for leak tightness	350
Checking the oil level	348

I	
Identification points	
Overview	8
Impermissible use	14
Information for carrying out maintenance	316
Maintenance timeframe	317
Information symbols	19
Inserting wedges	303
Insulation testing	46
Drive battery test values	47
Test values for the truck	47
Insurance cover on company premises ..	31
Interior lighting	230
Issue date of the operating instructions ..	19
J	
Jacking up	313
Joystick 4Plus	66
Fork-carriage sideshift	159
Lifting/lowering the fork carriage ...	158
Tilting the lift mast	159
L	
Lashing down	303
Left side cover	328
Attaching	328
Removing	328
Lift cut out	
Automatic	146
Lift cylinder	
Checking for leak tightness	356
Lift mast	
Lubricating the roller track	351
Removing	315
Securing against falling off	315
Securing against tilting backwards ..	314
Lift mast versions	
Triplex lift mast	152



Index

Lift mast vertical position	147	Load measurement	169
Automatic approach	149	Description	169
Calibrating	151	Execution	170
Description	147	Zero adjustment	91
Display	149	Lubricating the joints and controls	340
Possible restrictions	150		
Run-in to end stops	149	M	
Tilting the lift mast backwards	150	Maintenance	
Tilting the lift mast forwards	149	Removing and attaching the rear	
Lifting	313	cover	331
Lifting system		Maintenance data table	325
Controlling using a double		Battery	325
mini-lever	155	Controls/joints	325
Controlling using a quadruple		Cooling system (power electron-	
mini-lever	157	ics/hydraulic oil)	327
Controlling using a triple mini-lever	156	Drive axle	326
Controlling using the joystick 4Plus	158	Electrical system	325
Controlling with the fingertip		General lubrication points	325
console	160	Hydraulic system	325
Operating devices	154	Lift mast	326
Lighting		Load chains	327
STILL SafetyLight	218	Steering axle	326
Switching on and off	211	Tyres	326
List of abbreviations	20	Washer system	327
Lithium-ion batteries		Maintenance personnel for batteries	316
Changing the battery type	273	Maintenance work without special	
Load		qualifications	316
Picking up	175	Malfunctions during lifting mode	152
Setting down	180	Manual tow coupling	
transporting	179	Coupling	236
Load capacity	168	Uncoupling	238
Load chains		Medical equipment	36
Cleaning	288		



Message

! PARKING BRAKE OIL PRES- SURE	259
? VERTICAL POSITION	254
ACCELERATOR	252
APPLY HANDBRAKE	251
ARE YOU SURE ?	256
BRAKE SENSOR	251
CLOSE THE DOOR	260
CODE DENIED	252
EMERGENCY SWITCH	254
LIFT HEIGHT	260
LOWER FORKS	253
MOT/GEN. TEMP.	259
NOT VALID	259
OVERHEATING	258, 260
PARKING BRAKE ACTIVE	252
PARKING BRAKE: APPLY HANDBRAKE!	253
REFERENCE CYCLE	254
RELEASE PARKING BRAKE	252
SAFETY BELT	255
SEAT SWITCH	256
SERVICE BRAKE	250
STEERING	253
SURVEILLANCE	259
SWITCH OFF TRUCK?	252
TILTING SPEED	253

Messages

General	250
Mini console	68
Misuse of safety systems	34
MSG 65/MSG 75 driver's seat	
Adjusting	76
Adjusting the backrest extension	79
Adjusting the lumbar support	79
Adjusting the seat backrest	77
Adjusting the seat suspension	78
Moving	77
Switching the seat heater on and off ..	80

N

Nameplate	11
Neutral position	128

O

Oils	48
Opening the cab door	228
Opening the side windows	229
Operating company	28
Operating devices for hydraulic and driving functions	62
Operating materials	
Quality and quantity	322
Operating procedures	23
Operating the service brake	137
Operating the signal horn	82
Ordering spare parts and wearing parts .	322
Overhead guard	
Drilling	33
Roof loads	33
Welding	33
Overview	
Driver's compartment	60

P

Packaging	25
Parking brake	
Mechanical parking brake	138
Parking the truck securely	
Switching off the truck	144
Personnel qualifications	316
Picking up loads	172
Place of use	14
PowerPlusLife	
Cooling air flow	283
Diagnostic connector	285
Error messages	284
Fluid level	284
Internal error	285
Temperature monitoring	284
PowerPlusLife battery	282
Procedure if truck tips over	293



Index

Production number	12	Rules for roadways and the working area	125
Prohibition of use by unauthorised persons	30	S	
Proper usage	13	Safety devices	313
Push-up roof window	234	Safety inspection	46
Q		Safety regulations for maintenance	
Quadruple mini-lever		General information	312
Tilting the lift mast	157	Safety devices	313
R		Set values	313
Radiator		Working on the electrical equipment	312
Checking for leak tightness	336	Working on the hydraulic equipment	312
Cleaning	336	Safety regulations for working on the lift mast	314
Radio	231	Safety regulations when driving	121
Re-commissioning after shutdown	310	Safety regulations when handling loads	167
Rear cover		Safety regulations when handling the battery	265
Attaching	331	Battery weight and dimensions	266
Removing	331	Damage to cables and battery male connectors	267
Rear window heating	231	Fire protection measures	265
Reducing speed when turning	141	Lifting accessory	266
Reducing speed with a raised load	143	Maintenance personnel	265
Replacing the battery	276	Schematic views	23
General information	273	Scope of the documentation	
Replacing the fuses	346	UPA solutions	18
12-V technology	348	Seat belt	83
80-V technology	347	Checking	341
Front fuse box	347	Cleaning	342
Power distribution unit	347	Fastening	83
Rear fuse box	348	Fastening on a steep slope	84
Replacing the recirculated air filter for the heating system	343	Maintaining	341
Resetting the daily kilometres	114	Malfunction due to cold	85
Resetting the daily operating hours	114	Releasing	85
Residual dangers	39	Replacement after an accident	342
Residual risks	39	Selecting the drive direction	128
Retrofitting	31	Selecting the driver PIN	100
Reversible fork arm		Set values	313
Checking	357	Setting the date	114
Reversible fork arms	165	Setting the drive programme	125
Roadways	123, 125		
Rotating beacon	213		



Setting the language	115	Turn indicators	214
Setting the time	114	Mini-console version	215
Shock recognition	220	Mini-lever version	214
Shutdown		Types of lift mast	151
Re-commissioning	310	Telescopic mast	151
Shutting down the truck	308	Tyres	
Special risks	40	Safety principles	35
Spring-operated brake		U	
Releasing	296	Units	22
Sprint mode (variant)	127	Unlocking the emergency off switch	82
Stability	40	Using working platforms	16
Standard display elements	95	V	
Starting drive mode	131	Variant	
Dual pedal version	134	Ceiling sensor	222
Status LEDs	112	Variants	
Steering	140	Access authorisation with PIN code	95
Steering system		Automatic lift cut out	146
Checking for correct function	89	Clamp locking mechanism	207
Storing the truck	308	Clipboard	234
StVZO (Road Traffic Licensing Regulations) information	12	FleetManager	220
Switching on the key switch	93	Fork extension	163
T		Heating system	232
Technical data		Lift mast vertical position	147
Dimensions	360	Lifting systems	146
VDI datasheet	362	Load measurement	169
Three-way mini-lever	64	Push-up roof window	234
Lifting/lowering the fork carriage	156	Radio	231
Topicality of the operating instructions	19	Reducing speed with a raised load	143
Towed load	235	Reversible fork arms	165
Towing	299	Shock recognition	220
Proper use	13	Sprint mode	127
Trailers		Triplex lift mast	152
Towing	246	Wheel chock	145
Transportation	302	Windscreen wiper/washer	219
Transporting pallets	174	VDI datasheet	362
Transporting suspended loads	174	Vertical lift mast position	
Triple mini-lever		Checking for correct function	91
Tilting the lift mast	156	View of functions and operations	23
		View of operating procedures	23
		Views of the display operating unit	24



Index

Visual inspections	70	Working on the electrical equipment . . .	312
W		Working on the hydraulic equipment . . .	312
Warning regarding non-original parts . . .	34	Working spotlight for reverse travel	
Wheel chock	145	Switching on and off	212
Wheels and tyres		Working spotlights	
Checking condition and wear of the		Automatically switching on/off	217
tyres	344	Lift-height-controlled switching	
Checking the air pressure	345	on/off	217
Checking wheel fastenings	346	Manually switching on/off	216
Servicing	344	Switching on and off	212, 216
Windscreen wiper/washer	219	Z	
Working at the front of the truck	314	Zero adjustment of the load measure-	
		ment	91





