



T870 | Specifications

T870

Machine Rating

Rated operating capacity (ISO 14397-1)	1584 kg
Tipping load	4526 kg
Pump capacity	90.1 l/min
Pump capacity (with high flow option)	141.6 l/min
System relief at quick couplers	238–245 bar
Max. travel speed (low range)	10.5 km/h
Max. travel speed (high range)	18.3 km/h

Engine

Make / Model	Kubota / V3800-DI-T-E3
Fuel / Cooling	Diesel / Liquid
Maximum power	74 kW
Torque (SAE J1995)	325 Nm (at 1600 RPM)
Number of cylinders	4
Displacement	3769 cm ³

Weights

Operating weight	5751 kg
------------------	---------

Controls

Vehicle steering	Direction and speed controlled by two joysticks
Loader hydraulics tilt and lift	Selectable Joystick Control (SJC)
Front auxiliary (standard)	Electrical switch on right-hand joystick

Drive System

Transmission	Infinitely variable tandem hydrostatic piston pumps, driving two fully reversing hydrostatic motors
--------------	---

Fluid Capacities

Cooling system capacity with heater	18.5 l
Cooling system capacity w/o heater	15.1 l
Engine oil with filter capacity	11.4 l
Fuel tank capacity	134.8 l
Hydraulic reservoir capacity	11.4 l
Hydraulic / hydrostatic system capacity	36 l

Environmental

Operator LpA (EU Directive 2006/42/EC) / (uncertainty)	82.4 dB (A) / 2.5 dB (A)
Noise level LWA (EU Directive 2000/14/EC)	104 dB (A)
Whole body vibration (ISO 2631-1) / (uncertainty)	1.5 ms ⁻² / 0.6 ms ⁻²
Hand-arm vibration (ISO 5349-1)	0.49 ms ⁻²

Standard Features

- Selectable Joystick Controls (SJC)
- Roller Suspension™ undercarriage
- 450 mm rubber tracks
- Enclosed cab

Options

- High Flow Hydraulics
- Cab enclosure with heating
- Cab enclosure with heating and air conditioning
- Deluxe instrumentation panel
- Power Bob-Tach
- 2nd speed

Dimensions

All dimensions in mm.

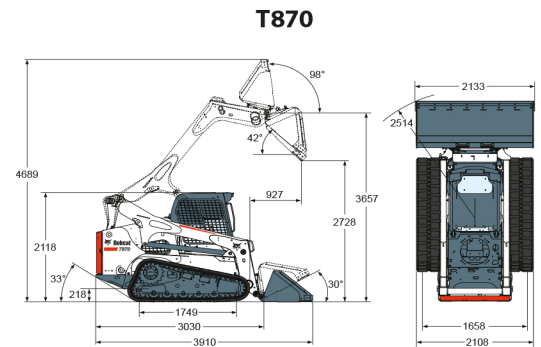

Specifications and design are subject to change without notice. Pictures of Bobcat products may show other than standard equipment.

