



YANMAR

MIDI-EXCAVATOR

ViO80-1

8065 / 8125 kg





ViO80-1



> **EQUIPMENT**

> **STANDARD EQUIPMENT**

Engine

- 4TNV98C-WBV Yanmar diesel
- Meets Phase IIIB and Tier 4 standards
- Direct Injection
- Common Rail System
- EGR Electrical Control System
- Engine Control Unit (ECU)
- Particle filter with automatic regeneration (without additives)
- Water Separator
- Eco Mode
- Auto-Idle System (auto deceleration)
- Throttle using potentiometer

+

Hydraulic system

- VIPPS Hydraulic system (ViO progressive 3 pump system)
- 2 auxiliary circuits with adjustable proportional control by potentiometer
- Electronic regulation of hydraulic pumps
- Automatic 2nd speed
- Filter on steering hydraulic circuit
- External hydraulic oil gauge

+

Cabin

- LCD Interface
- Cabin mounted on viscoelastic silent blocks
- Air conditioning
- Adjustable and reclining seat with

- fabric covers, air suspension and headrest
- Adjustable wrist support
- Foot rests
- Wide travel pedals
- Windshield with 2 fully retractable parts
- Sliding double right side window
- Transparent upper front part
- Visor
- Wipers
- Windshield washer
- Automatic ceiling lamp
- Radio with USB port
- 2 x 12V outlets
- Storage Boxes
- Secure document storage
- Cup Holder

+

Undercarriage

- Asymmetric VICTAS tracks
- Blade cylinder supply hose into two parts

+

Safety

- Handrails
- Safety lever
- Seat belt with retractor
- Evacuation hammer
- Anchor points
- 5 mirrors
- Horn
- Travel beep

Lighting

- 1 LED light integrated into the boom
- 2 LED lamps on the front of the cab

+

Miscellaneous

- Electric refuelling pump with automatic stop
- Fuel gauge
- Double axis position of the arm cylinder
- Protection of the blade and boom cylinders
- Hoses protected by abrasion-resistant sleeves.
- Cataphoresis treated steel parts
- Locking Covers
- Toolbox
- Toolkit
- Grease pump

OPTIONAL EQUIPMENT

Special paint | Safety valves for lifting + overload warning | Long arm | Additional counterweight (+400 kg) | Prolongation of the auxiliary circuits to arm end | Quick couplings | Anti-theft (key/keyboard) | GPS Tracking | Centralised greasing | Skai seat | LED rear light + flashing light | FOPSII protection grid

ACCESSORIES

Yanmar gives you the accessories that fit your needs and match the safety standards in force in your country: mechanical quick coupler, hydraulic quick coupler, ditching bucket, swinging bucket, backhoe bucket, hydraulic hammer...

ViO80-1



DIMENSIONS <

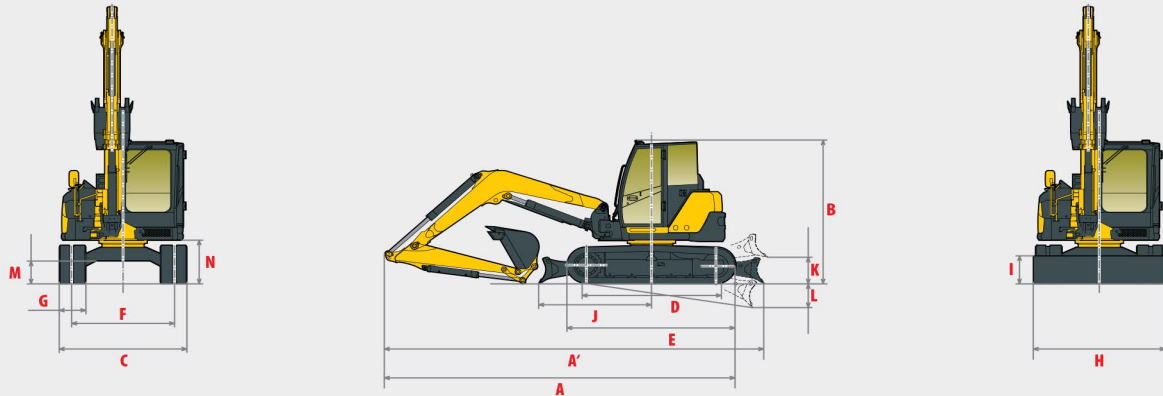

| | | | |
|---|-----------------|---|---------|
| A » Overall length | 6410 / 6450* mm | H » Overall blade width | 2260 mm |
| A' » Overall length with blade at the back | 6920 / 6960* mm | I » Overall blade height | 450 mm |
| B » Overall height | 2710 mm | J » Blade distance | 2030 mm |
| C » Overall width | 2270 mm | K » Max. lifting height above the ground | 460 mm |
| D » Length of track on ground | 2290 mm | L » Max. lowering depth from the ground | 480 mm |
| E » Undercarriage length | 2890 mm | M » Minimum ground clearance | 380 mm |
| F » Lane | 1870 mm | N » Ground clearance under counterweight | 700 mm |
| G » Track width | 450 mm | | |

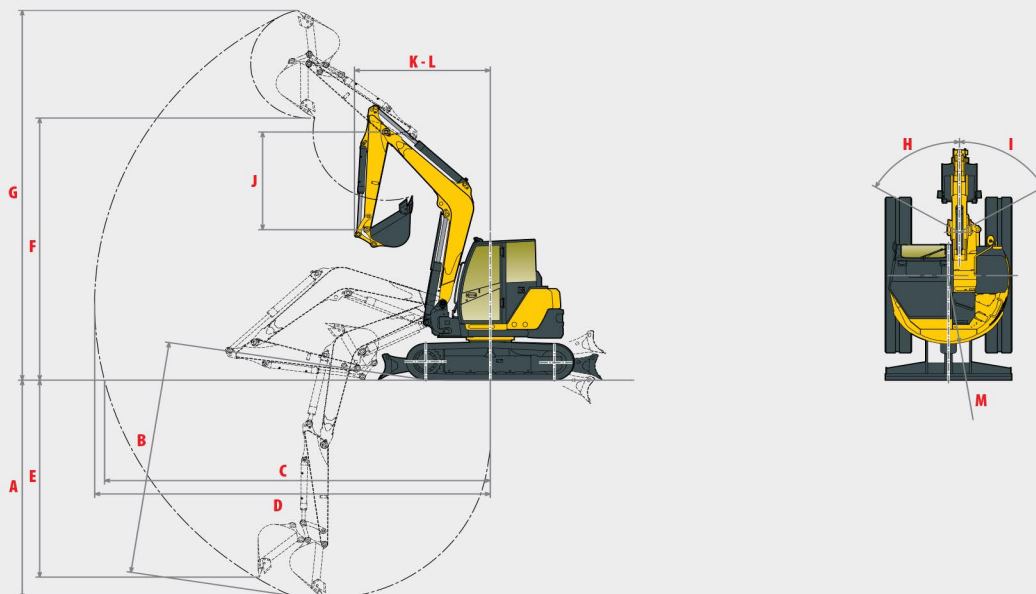

| | | | |
|---|-----------------|---|-----------------|
| A » Max. digging depth - Blade lifted | 4130 / 4500* mm | H » Boom swinging base to left | 57° |
| B » Max. digging depth - Blade lowered | 4430 / 4790* mm | I » Boom swinging base to right | 60° |
| C » Max. digging reach on ground | 6820 / 7160* mm | J » Arm length | 1650 / 2000* mm |
| D » Max. digging reach | 6960 / 7290* mm | K » Front boom swing | 2470 / 2520* mm |
| E » Max vertical wall | 3780 / 4130* mm | L » Front turning radius with boom swing | 2130 / 2170* mm |
| F » Max. unloading height | 4700 / 4950* mm | M » Rear boom swing | 1135 mm |
| G » Max. cutting height | 6810 / 7020* mm | M' » Rear boom swing with additional counterweight | 1265 mm |

*Long arm

Subject to technical modifications. Dimensions in mm with specific Yanmar bucket.



ViO80-1



> **LIFTING FORCE**



Tipping load,
rating over front



Tipping load,
rating over side 90°

| Standard counterweight, standard arm | | | | | | | | | | | | | | | | | | | | | | | | | | | | | | | |
|--------------------------------------|-----|--------------------|------|------|------|------|------|-----------------|---------------------|--------------------|------|------|------|------|------|------|------|------|------|------|------|------|------|------|------|------|------|------|------|------|------|
| With tiltrotator* | | | | | | | | | Without tiltrotator | | | | | | | | | | | | | | | | | | | | | | |
| Blade on ground | | Blade above ground | | | | | | Blade on ground | | Blade above ground | | | | | | | | | | | | | | | | | | | | | |
| A | Max | 5 m | | 4 m | | 3 m | | Max | 5 m | | 4 m | | 3 m | | | | | | | | | | | | | | | | | | |
| B | | | | | | | | | | | | | | | | | | | | | | | | | | | | | | | |
| 5 m | - | - | - | - | - | - | - | - | 1730 | 1720 | 1750 | 1740 | - | - | 1740 | 1750 | 1720 | 1720 | | | | | | | | | | | | | |
| 4 m | - | - | 976 | 1432 | 1036 | 1522 | 1532 | 1502 | 1100 | 1090 | 1680 | 1150 | 1190 | 1190 | 1680 | 1250 | 1770 | 1780 | 1720 | 1720 | 1720 | | | | | | | | | | |
| 3 m | 746 | 1442 | 796 | 996 | 986 | 1532 | 1056 | 1526 | 1832 | 1812 | - | - | - | 960 | 950 | 1690 | 1010 | 1210 | 1200 | 1780 | 1270 | 1740 | 1720 | 2080 | 2060 | 2490 | 2480 | 2500 | 2480 | | |
| 2 m | 666 | 656 | 1412 | 706 | 976 | 976 | 1672 | 1046 | 1526 | 1516 | 1626 | - | - | 880 | 870 | 1660 | 920 | 1190 | 1190 | 1920 | 1260 | 1740 | 1730 | 2480 | 1860 | 2500 | 2460 | 3400 | 2650 | | |
| 1 m | 656 | 646 | 1432 | 686 | 926 | 926 | 1832 | 996 | 870 | 860 | 1680 | 900 | 1140 | 1140 | 2080 | 1210 | 1630 | 1620 | 2860 | 1720 | 2230 | 2190 | 2230 | 2190 | 2860 | 1720 | 2230 | 2190 | 3860 | 2350 | |
| 0 m | 696 | 676 | 1462 | 726 | 896 | 886 | 1882 | 946 | 910 | 890 | 1710 | 940 | 1110 | 1100 | 2130 | 1160 | 1580 | 1560 | 2920 | 1630 | 2220 | 2180 | 2220 | 2180 | 2920 | 1630 | 2220 | 2180 | 3880 | 2320 | |
| -1 m | 776 | 756 | 1442 | 806 | - | - | - | - | 990 | 970 | 1690 | 1100 | 1100 | 2010 | 1140 | 1590 | 1560 | 2740 | 1630 | 2370 | 2340 | 2370 | 2340 | 2370 | 2340 | 2740 | 1630 | 2370 | 2340 | 3750 | 2540 |
| -2 m | - | - | - | - | - | - | - | - | 1200 | 1190 | 1610 | 1100 | 1100 | 1140 | 1590 | 1570 | 2260 | 1640 | 2620 | 2620 | 2620 | 2600 | 2620 | 2600 | 2620 | 2600 | 2620 | 2600 | 3740 | 3000 | |
| -3 m | - | - | - | - | - | - | - | - | 1360 | 1360 | 1350 | - | - | - | - | - | 1570 | 1640 | 1560 | 1560 | 1560 | 1560 | 1560 | 1560 | 1560 | 1560 | 1560 | 1560 | 1560 | 1550 | |

¹ Rototilt of 285 kg

The data in this table represents the lifting capacity in accordance with ISO 10567. They do not include the weight of the bucket and correspond to 75% of the maximum static tipping load or 87% of the hydraulic lifting capacity. Data marked with * are the hydraulic limits of the lifting force.

ViO80-1



SPECIFICATIONS <

| WEIGHT +/- 2% (CE STANDARDS)

| | Weight | Ground pressure |
|----------------------------------|----------|--------------------------|
| Operating weight (rubber tracks) | 8,065 kg | 0.358 kg/cm ² |
| Transport weight (rubber tracks) | 7,990 kg | 0.358 kg/cm ² |
| With steel tracks | + 60 kg | 0.360 kg/cm ² |
| Additional counterweight | + 400 kg | 0.4 kg/cm ² |
| With FOPS II protection | + 100 kg | 0.362 kg/cm ² |

| ENGINE

| | |
|----------------|--------------------------------------|
| Type | 4TNV98C-WBV |
| Fuel | Diesel |
| Net Power | 40.7 kilowatts / 55.3 hp / 2,000 rpm |
| Gross Power | 42.2 kilowatts / 57.3 hp / 2,000 rpm |
| Displacement | 3,318 cm ³ |
| Maximum torque | 241 Nm / 1300 rpm |
| Cooling | Liquid |
| Starter | 3 kW |
| Battery | 12 V – 92 Ah |
| Alternator | 12 V – 80 A |

| HYDRAULIC SYSTEM

| | |
|---|----------------|
| Maximum pressure | 255 bar |
| 1 double piston pump with variable flow | 2 x 70.3 l/min |
| 1 piston pump with variable flow | 53.2 l/min |
| 1 gear pump | 19 l/min |

| PTO | Theoretical data at 1900 rpm | |
|---|------------------------------|----------------|
| | Pressure | Oil flow |
|  | 0 ~ 240 bar | 120 ~ 32 l/min |
|  | 0 ~ 240 bar | 120 ~ 32 l/min |



Oil flow decreases as the pressure increases

| PERFORMANCE

| | |
|---------------------------------------|---|
| Travel speed | 2.5 / 4.5 km/h (2.3 / 4.1 km/h with steel tracks) |
| Rotation speed | 9 rpm |
| Digging force (arm) | 40,8 kN (4,160 kgf) / 35,9 kN (3,360 kgf) with long arm |
| Digging force (bucket) | 63.5 kN (6,480 kgf) |
| Traction force | 61 kN |
| Grade ability | 30° |
| Noise level (2000/14/CE & 2005/88/CE) | 73 dB(A) / 98dB(A) (LwA) |

| UNDERCARRIAGE

| | |
|--------------------------|-------------------|
| Number of top rollers | 1 |
| Number of bottom rollers | 5 |
| Track tensioning system | Using grease pump |

| CAPACITIES

| | |
|-------------------|--------|
| Fuel tank | 115 l |
| Coolant | 9.3 l |
| Engine oil | 11.2 l |
| Hydraulic circuit | 112 l |
| Hydraulic tank | 60 l |

MAINTENANCE FREQUENCY

Change engine oil and filter: **250 hours** | Change fuel filter: **500 hours** | Change hydraulic oil filter: **1,000 hours** |
 Change hydraulic oil filter: **1,000 hours** | Change cooling fluid: **1,000 hours** | Clean particulate filter: **3,000 hours** |
 Change particle filter: **9,000 hours**